

# KINCAID

—SOLID WOOD SINCE 1946—

www.kincaidfurniture.com

phone :828-728-3261.

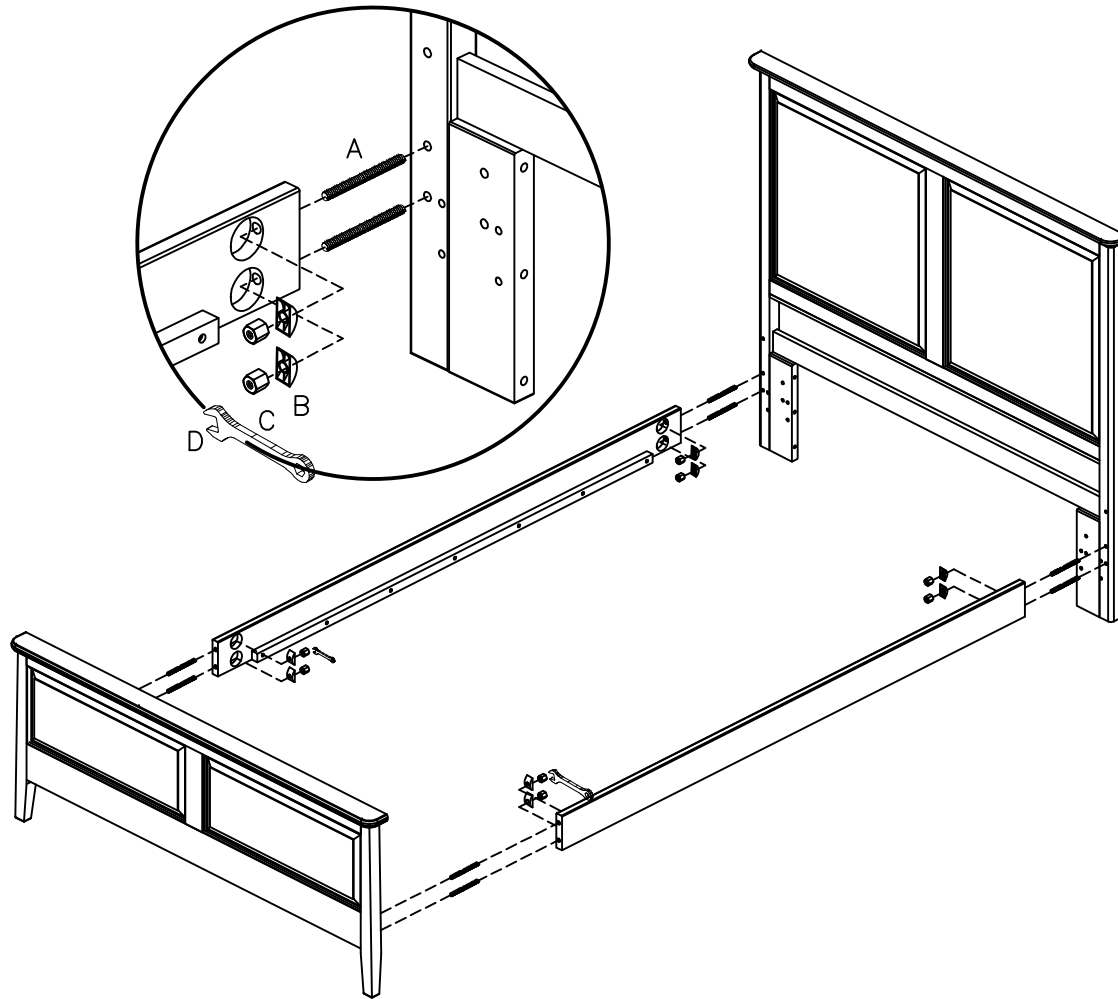

MADE IN VIETNAM





## Assembly Instructions

63-135HV/63-135FV/63-305V Bed 5-0

63-136HV/63-136FV/63-305V Bed 6-6

63-136HV/63-136FV/63-306V Bed 6-0

## Hardware List

CODE	DESCRIPTION	QTY
A	 Threaded Bolts Ø 5/16" x 4"	8
B	 Curve Washers Ø 5/16"	8
C	 Nut Ø 5/16"	8
D	 Spanner Wrench 12mm	1

### IMPORTANT NOTES

- . Place all wooden parts on clean and smooth surface such as rug or carpet to prevent the parts from being scratched.
- . Check to be sure that you have all parts and hardware.
- . Remove all wrapping materials, including staples and packing straps before you start to assemble.
- . Do not tighten all screws and bolts until completely assembled.
- . Keep all hardware out of the reach of children

- Step 1: Insert the eight threaded bolt (A) into the headboard and footboard. Tighten by hand only.
- Step 2: Insert the side rails onto the threaded bolts protruding from the headboard. Attach curve washer (B) and nut (C) onto the threads and secure by hand at first. Tighten evenly using the open wrench (D).
- Step 3: Insert the side rails onto the threaded bolts protruding from the footboard. Attach curve washer (B) and nut (C) onto the threads and secure by hand at first. Tighten evenly using the open wrench (D).