

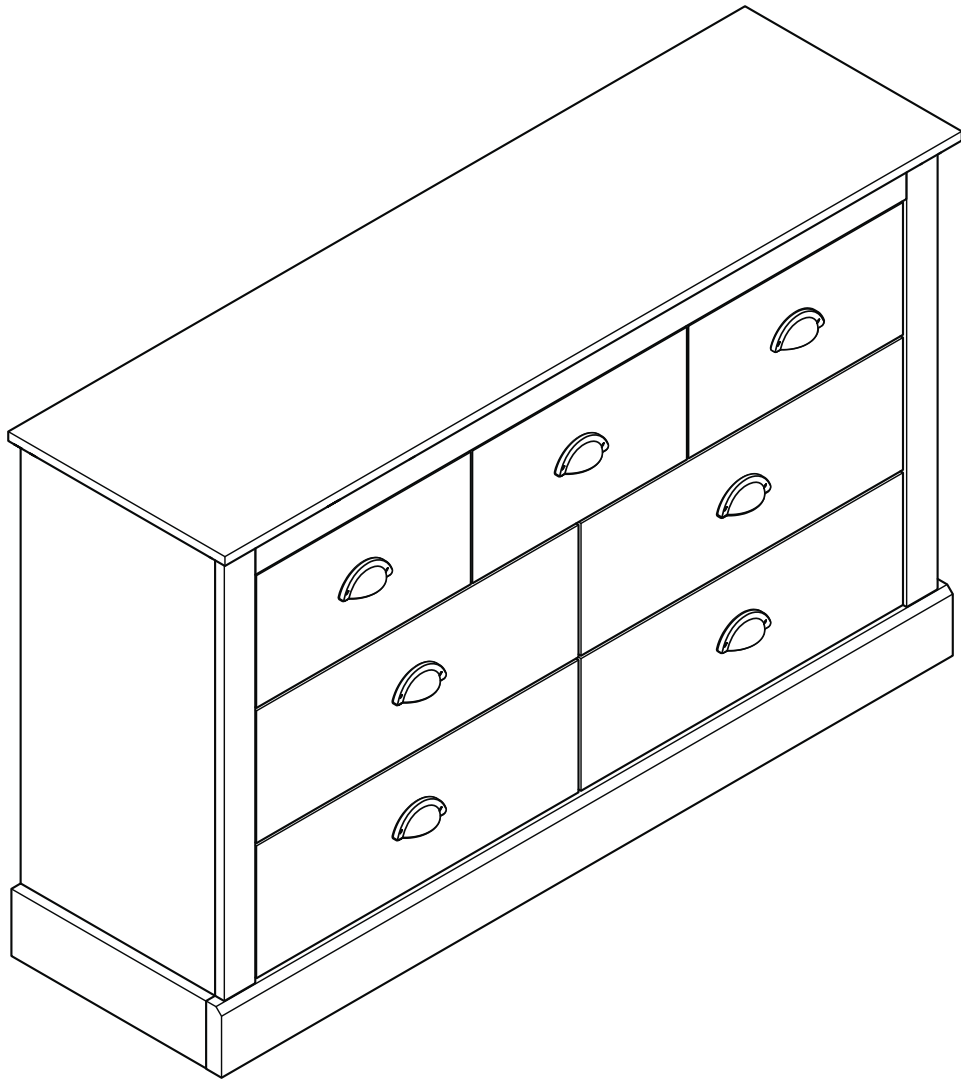





**ASSEMBLY INSTRUCTIONS / INSTRUCTIONS
D'ASSEMBLAGE / INSTRUCTIVO DE ARMADO**



NOTES ON ASSEMBLY / NOTES POUR L'ASSEMBLAGE / NOTAS SOBRE EL ENSAMBLE

- To ensure ease of assembly read all instructions before assembly and follow step by step illustrations.
- Keep instructions for future use.
- Adult assembly required.  2 person required. 
- Due to the presence of small parts during assembly, keep out of reach of children until assembly is complete.

- Pour assurer l'assemblage facile veuillez lire toutes les instructions avant l'assemblage et veuillez suivre les illustrations pour chaque etapes.
- Veuillez garder ces instructions pour l'usage ulterieur.
- Assemblage requis pas un adulte.  2 personnes requises. 
- Due a la presence de petite pieces durant l'assemblage, veuillez garder hors de porter des enfants jusqu'a ce que l'assemblage soit completer.

- Para garantizar la facilidad de ensamble lea las instrucciones antes de iniciar y siga paso a paso las ilustraciones.
- Guarde las instrucciones para futuras referencias.
- El ensamble requiere de un adulto.  2 personas requeridas. 
- Debido a que hay piezas pequeñas, mantenga fuera del alcance a los niños durante el ensamble, hasta que haya terminado.

MAINTENANCE TIPS / CONSEILS D'ENTRETIEN / CONSEJOS DE MANUTENIMIENTO

- Never let liquids or damp cloths sit on this furniture.
- Never use chemical cleaning products. They can damage the finish. For cleaning, use only a slightly damp cloth and wipe dry.
- To avoid dulling of the finish, do not place furniture in direct sunlight.
- Do not put plastic or rubber rings under appliances. Use cloth of felt protectors.
- To clean, use a soft or slightly damp cloth, then wipe with a clean, dry cloth.

- Ne jamais laisser de liquide ou linge humide sur le meuble.
- Ne jamais utiliser de nettoyeurs à base de produits chimiques, cela va endommager le fini. Utiliser seulement un linge légèrement humide.
- Ne pas placer le meuble directement au soleil pour prévenir le ternissement.
- Évitez de déposer des appareils avec des rondelles de plastique ou de caoutchouc. Utilisez un protecteur en tissu ou en feutre.
- Pour nettoyer, utilisez un linge doux ou légèrement humecté. Essuyez par la suite avec un linge propre et sec.

- Nunca deje un líquido o un trapo húmedo sobre el mueble.
- Nunca utilice limpiadores a base de químicos, estos dañaran le acabado. Use sólo un paño húmedo.
- No esponga el mueble directamente al sol para prevenir empañamiento.
- Evite apoyar aparatos con redondeles de plástico o de goma. Utilizar un protector de tela o de fieltro.
- Para limpiar, utilice un trapo suave o ligeramente humedecido. Seque luego con un trapo limpio y seco.

WARNING AVERTISSEMENT / ADVERTENCIA

Please use your furniture correctly and safely. Improper use can cause safety hazards, or damage to your furniture or household items.

Serious or fatal crushing injuries can occur from furniture tip-over.

To help prevent tip-over:

- Place heaviest items in the lowest drawers.
- Do not set TVs or other heavy objects on the top of this product. Never allow children to climb or hang on drawers, doors, or shelves.
- Never open more than one drawer at a time.
- Always monitor your child's activity when in the nursery.
- Do not allow standing in drawers.
- Do not allow standing on top of this product.
- Accessory Items must be securely fastened to this product according to the instructions provided with those items.
- To avoid head injury, do not allow children to play underneath open drawers.
- Do not leave drawers open when not in use.

Use of tip-over restraints reduce, but does not eliminate, the risk of tip-over.

Prrière d'utiliser le mobilier à bon escient et avec prudence. Une mauvaise utilisation peut être à l'origine de risques d'accident ou peut endommager le mobilier et les articles ménagers.

Des blessures graves ou fatales peuvent résulter de basculement du meuble.

Afin de prévenir le basculement :

- Placer les items les plus lourds dans les tiroirs du bas.
- Ne pas placer de TV ou d'autres objets lourds sur ce produit. Ne jamais laisser un enfant grimper sur les tiroirs, les portes et les tablettes ou s'accrocher à ceux-ci.
- Ne jamais ouvrir plus d'un tiroir à la fois.
- Toujours surveiller votre activité de l'enfant lorsqu'à la pépinière.
- Ne pas laisser debout dans des tiroirs.
- Ne pas laisser debout sur ce produit.
- Les accessoires doivent être solidement fixés sur ce produit selon les instructions fournies avec ces éléments.
- Pour éviter toute blessure à la tête, ne pas laisser les enfants jouer sous les tiroirs ouverts.
- Ne pas laisser ouvrir les tiroirs lorsqu'il n'est pas utilisé.

L'utilisation de dispositif antibasculement ne peut que réduire les risques de basculement, sans les éliminer

Por favor use el mobiliario correcta y seguramente. El mal uso puede causar riesgos de seguridad o daño a las unidades o artículos domésticos.

El vuelco del mueble puede ser causa de lesiones graves o de un aplastamiento fatal.

Para evitar la volcadura:

- Ponga las cosas pesadas en los cajones más bajos.
- No ponga televisores u otros objetos pesados encima de este producto. Nunca permita que un niño se trepe o se cuelgue en cajones, puertas o estantes.
- Nunca abra más de un cajón a la vez.
- Siempre supervisa la actividad de su hijo cuando en el vivero.
- No dejar reposar en los cajones.
- No permiten de pie en la parte superior de este producto.
- Los elementos accesorios deben sujetarse firmemente a este producto de acuerdo a las instrucciones provistas con esos elementos.
- Para evitar lesiones en la cabeza, no permita que los niños jueguen debajo abrir cajones.
- No deje los cajones abiertos cuando no está en uso.

El uso de sujetadores para evitar el vuelco sólo puede disminuir el riesgo de un vuelco, pero no lo elimina.

MINIFIX CAM & MINIFIX BOLT
CAMÉRA MINIFIX & BOULON MINIFIX
CÁMARA MINIFIX & PERNO MINIFIX

MINIFIX BOLT
BOULON MINIFIX
PERNO MINIFIX

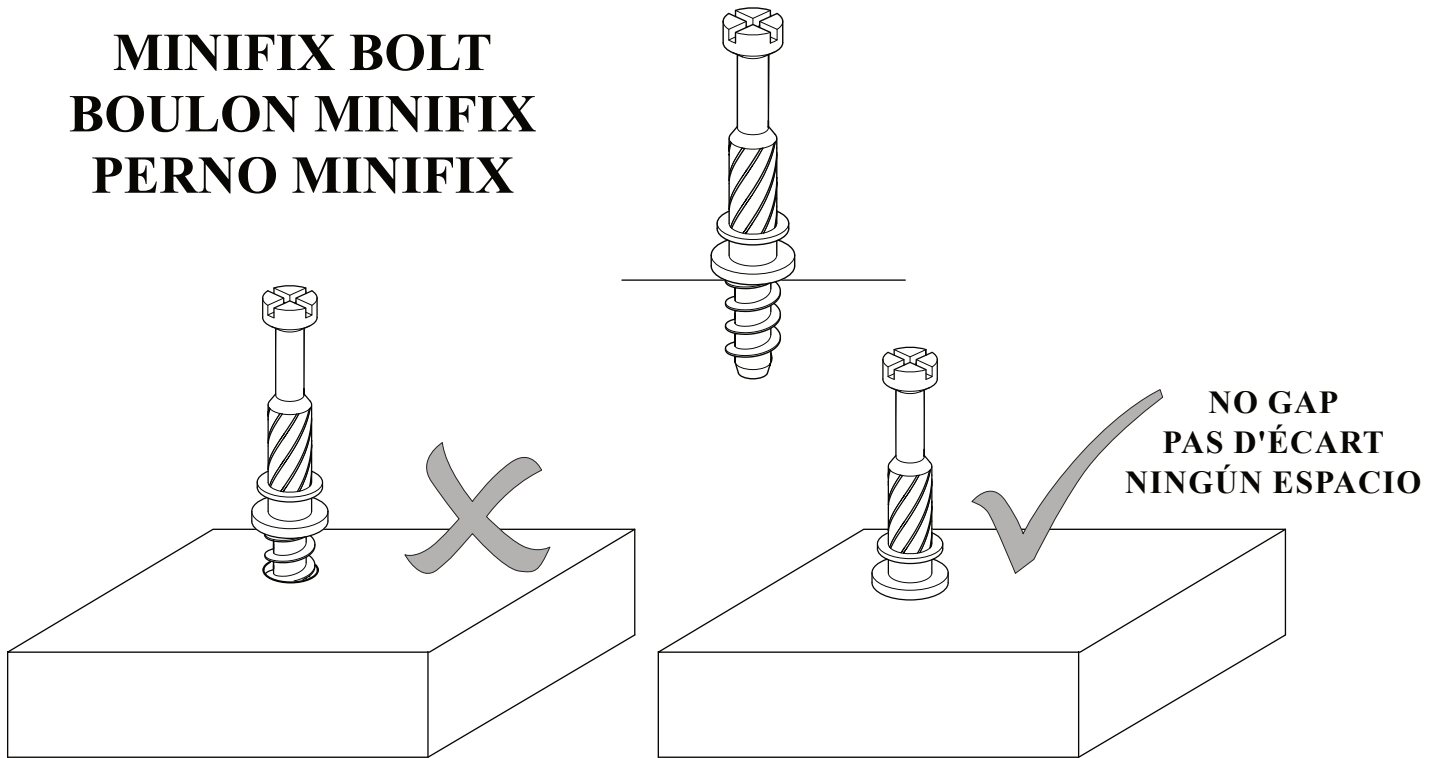

MINIFIX CAM
CAMÉRA MINIFIX
CÁMARA MINIFIX

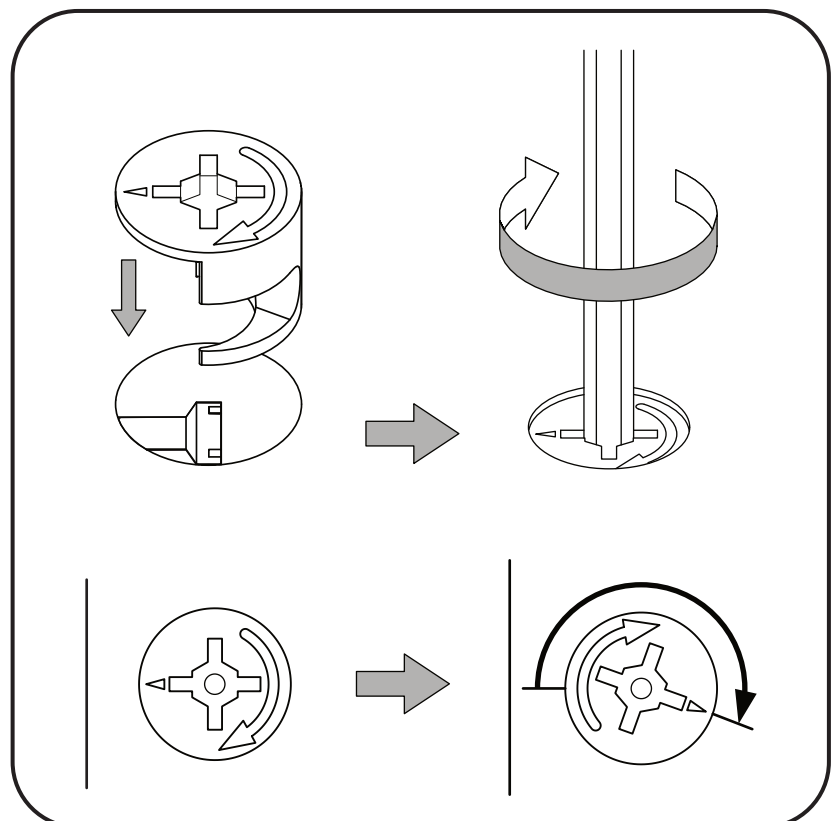
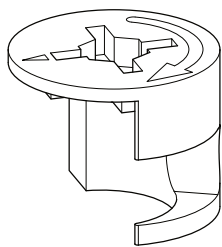

SPECIAL TIPS FOR FITTING DRAWER CONSEJOS ESPECIALES PARA EL MONTAJE DEL CAJÓN CONSEILS SPÉCIAUX POUR LE MONTAGE DU TIROIR

DRAWER RUNNER - A

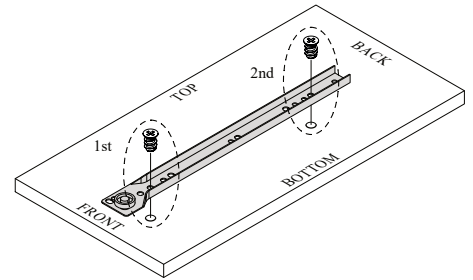
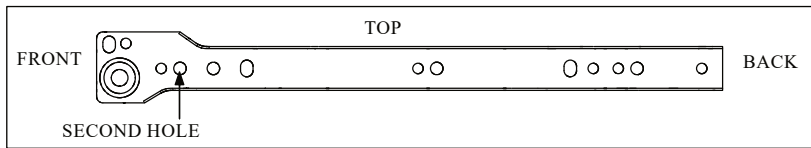

- Fix the first screw on the second hole on drawer runner as shown.
Fije el primer tornillo en el segundo orificio de la guía del cajón como se muestra
Fixez la première vis sur le deuxième trou de la glissière du tiroir comme indiqué
- Fix the second screw following the holes on panel.
Fije el segundo tornillo siguiendo los agujeros en el panel
Fixez la deuxième vis en suivant les trous sur le panneau

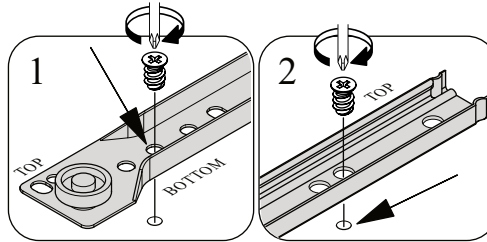

- Ensure the position of the drawer runner is correct as showed above.
Asegúrese de que la posición de la guía del cajón sea la correcta, como se muestra arriba.
Assurez-vous que la position de la glissière du tiroir est correcte comme indiqué ci-dessus.

DRAWER RUNNER - B

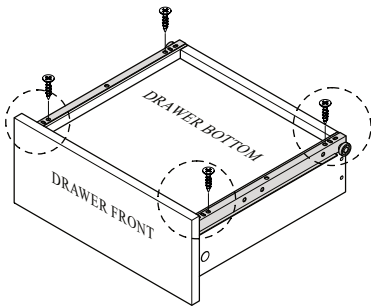
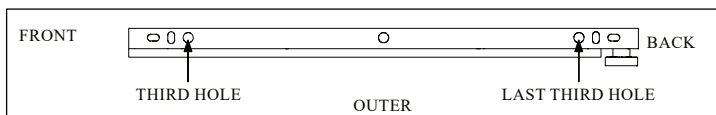

- Ensure the position of the drawer runner is correct as showed above.
Asegúrese de que la posición de la guía del cajón sea la correcta, como se muestra arriba.
Assurez-vous que la position de la glissière du tiroir est correcte comme indiqué ci-dessus.

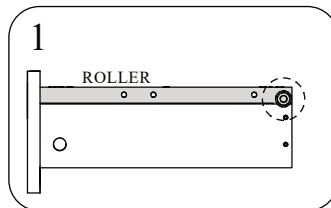

- Push the runner to drawer front.
Empuje la guía hasta el frente del cajón.
Poussez la glissière vers l'avant du tiroir.

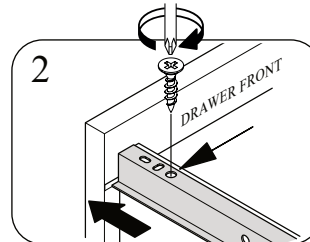

- Fix the first screw on the third hole from front.
Fije el primer tornillo en el tercer orificio desde el frente.
Fixez la première vis sur le troisième trou à partir de l'avant.

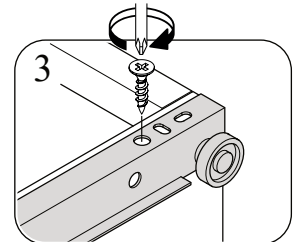

- Fix the second screw on the last third hole.
Fije el segundo tornillo en el último tercer orificio.
Fixez la deuxième vis sur le dernier troisième trou

INSTALL DRAWER TO CABINET / INSTALE EL CAJÓN AL GABINETE / INSTALLER LE TIROIR SUR L'ARMOIRE

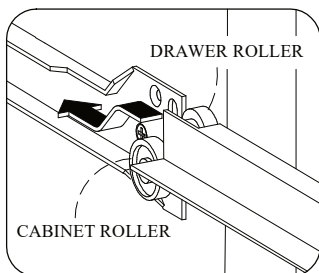

- Locate both roller on drawer box and roller on cabinet.
Ubique tanto el rodillo en la caja del cajón como el rodillo en el gabinete.
Localisez à la fois le rouleau sur la boîte à tiroirs et le rouleau sur l'armoire

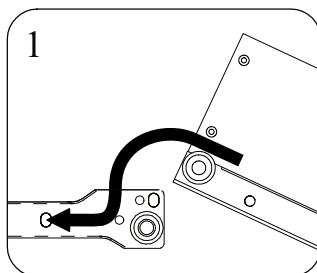

- Align the roller on drawer box on top of the roller on cabinet.
Alinee el rodillo en la caja del cajón en la parte superior del rodillo en el gabinete.
Alignez le rouleau sur la boîte à tiroirs sur le dessus du rouleau sur l'armoire.

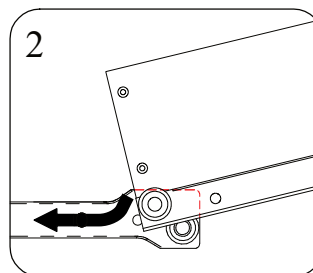



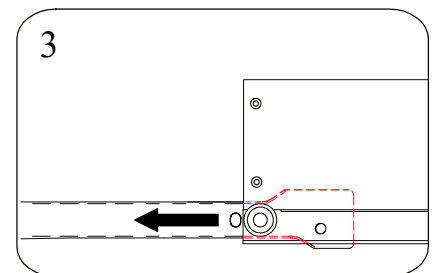



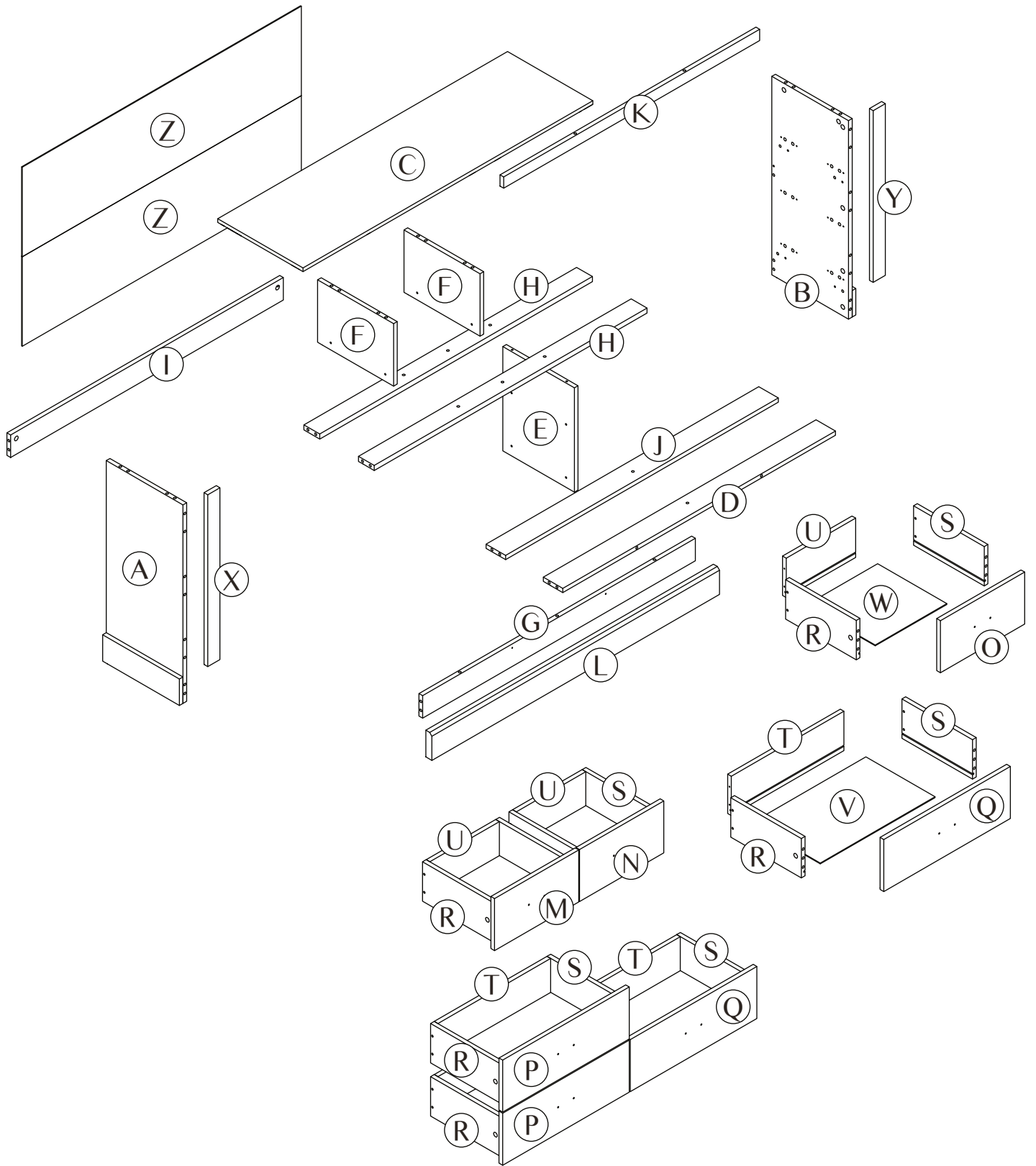





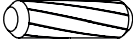
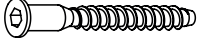





- Push inside the drawer box.
Empuje dentro de la caja del cajón.
Poussez à l'intérieur de la boîte à tiroirs



- Ensure the roller is in the track of drawer slide before push to the end.
Asegúrese de que el rodillo esté en el riel de la corredera del cajón antes de empujarlo hasta el final.
Assurez-vous que le rouleau est dans le rail de la glissière du tiroir avant de pousser jusqu'au bout.

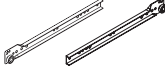

HARDWARE QUINCAILLERIE / HERRAJE



(A)	Minifix Bolt EU 24  40 units	(B)	Minifix Cam 15/12  40 units	(C)	Dowel M8 x 30mm  65 + 2 units
(D)	Unita M6.3 x 50mm  8 units	(E)	Screw M3.5 x 15mm  56 + 2 units	(F)	Screw M4 x 38mm  28 units
(G)	Nail Pin 3/4"  20 units	(H)	Nail Leg 5/8"  6 units	(I)	Allen Key Z (M4)  1 unit
(J)	PVC Block  12 units	(K)	Screw M4 x 20mm  24 + 2 units	(L)	Safety Strap + Washer  1 unit
(M)	Screw M3.5 x 25mm  1 unit	(N)	Handle (L - 82mm / H - 64mm)  7 units	(O)	Screw #6 x 16mm  14 units
(P)	Drawer Slide 300mm  7 sets	(Q)	Drawer Slide 300mm  7 sets	(R)	L Bracket  8 units
(S)	Screw M6 x 8mm  16 + 2 units				

- Hardware quantity may supplied more than it required. Please keep spares and tools for future use.
- La cantidad de hardware puede suministrarse más de lo requerido. Guarde los repuestos y las herramientas para uso futuro.
- La quantité de matériel peut fournir plus que nécessaire. Veuillez conserver les pièces de rechange et les outils pour une utilisation future.

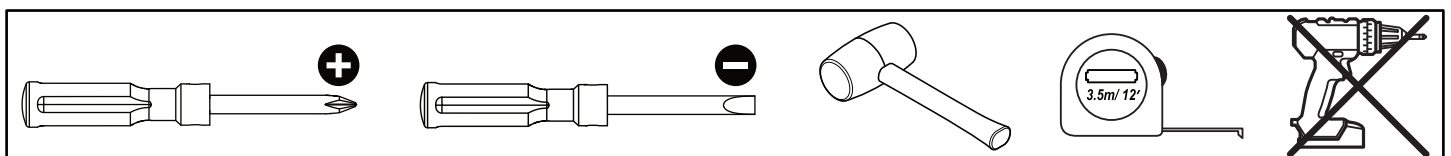
TOOLS NOT INCLUDED OUTILS PAS INCLUS / HERRAMIENTAS NO INCLUIDAS



STEP 1

	
J x 12	K x 24

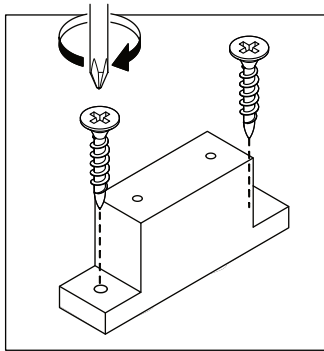
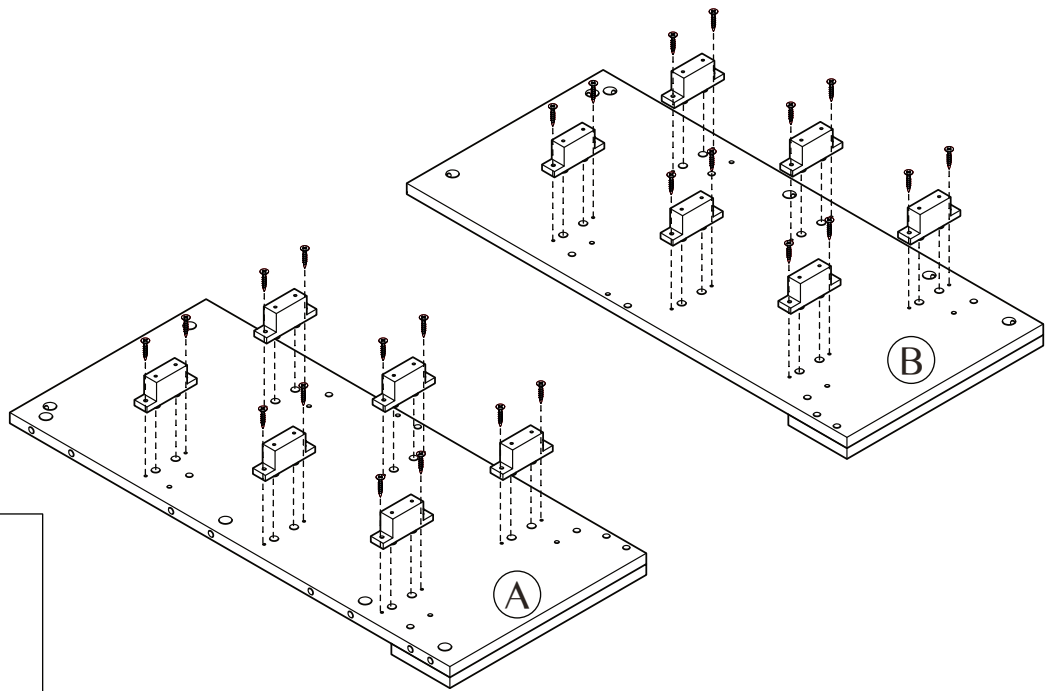

STEP 2

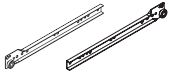
	
E x 12	P x 3

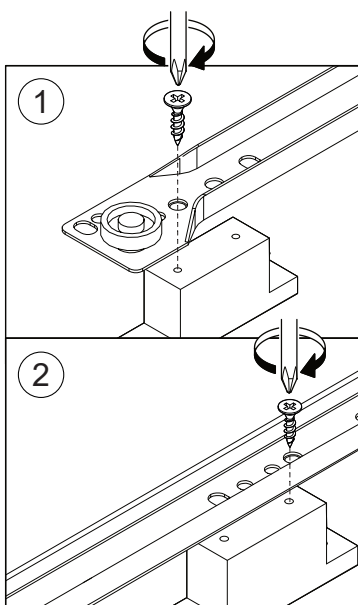
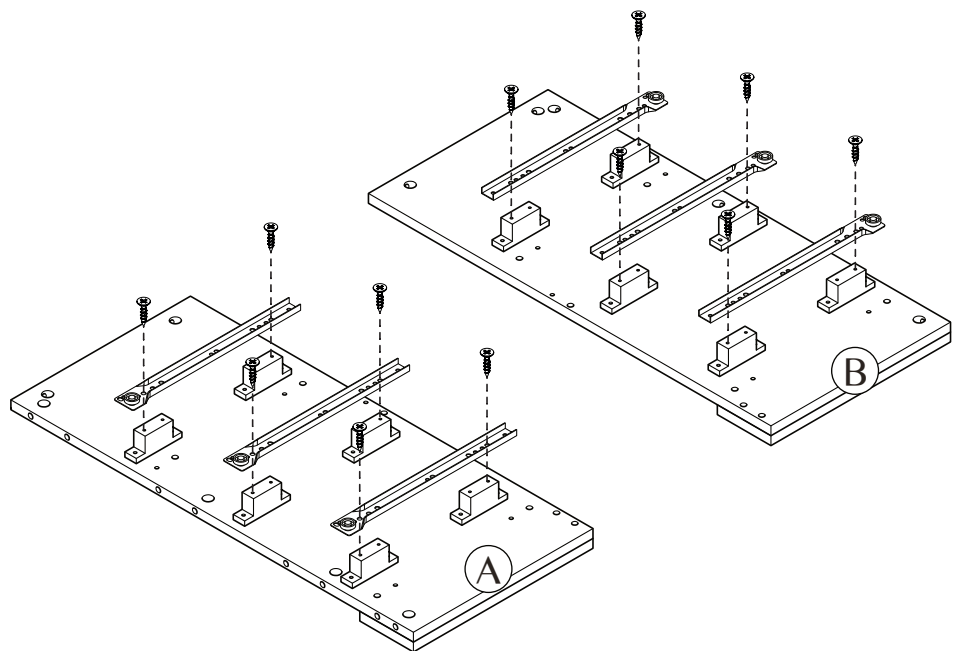

STEP 3

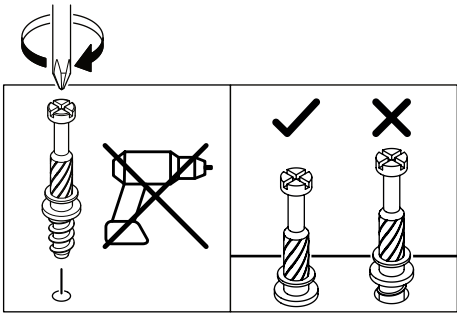
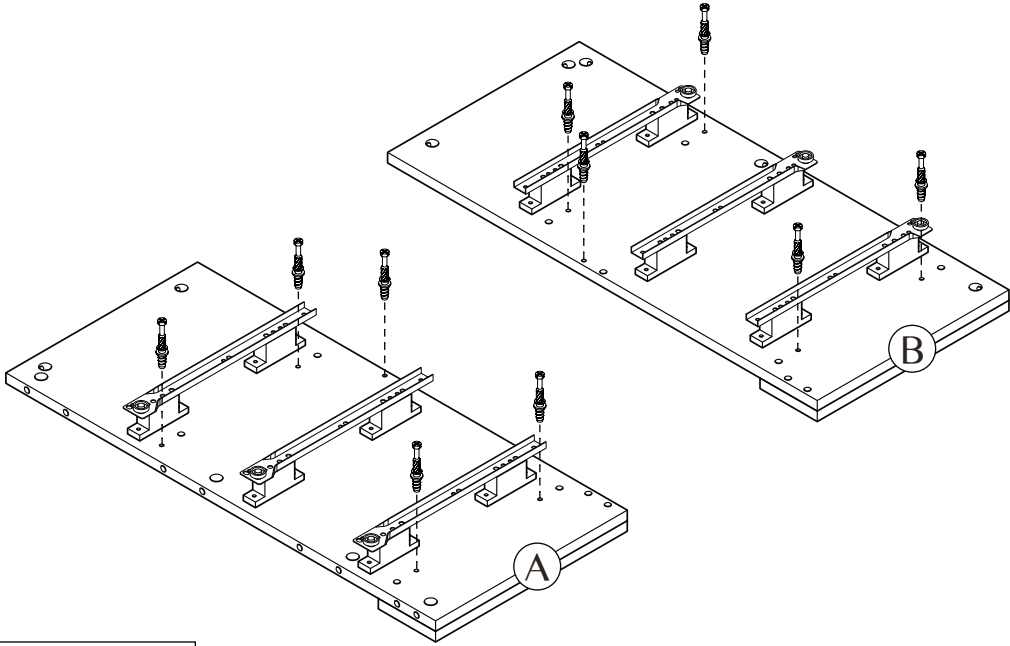
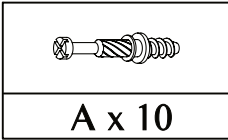

STEP 4

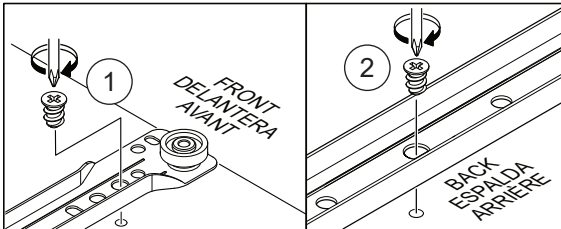
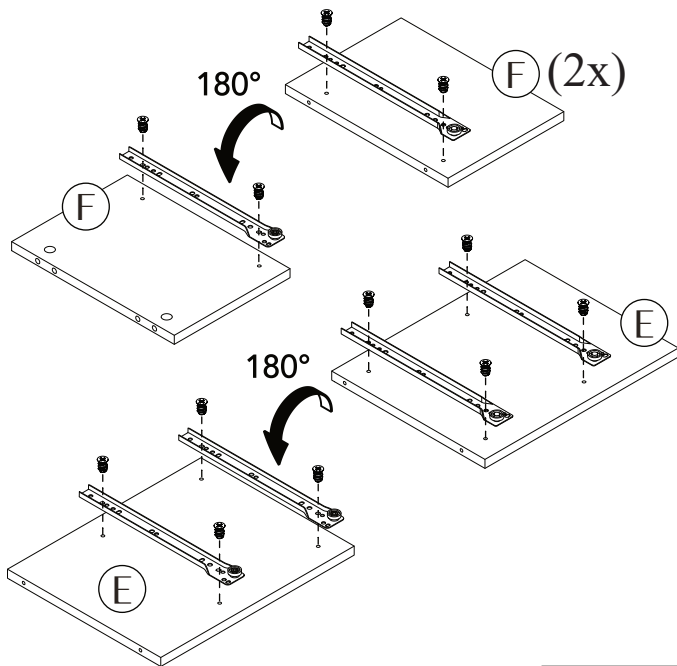
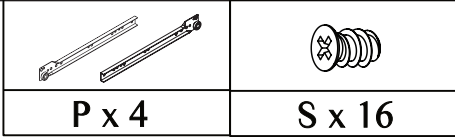

STEP 5

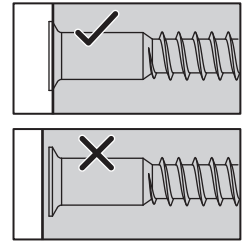
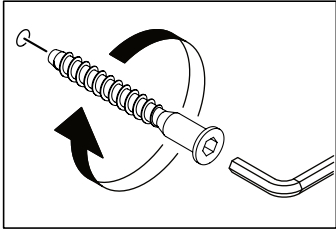
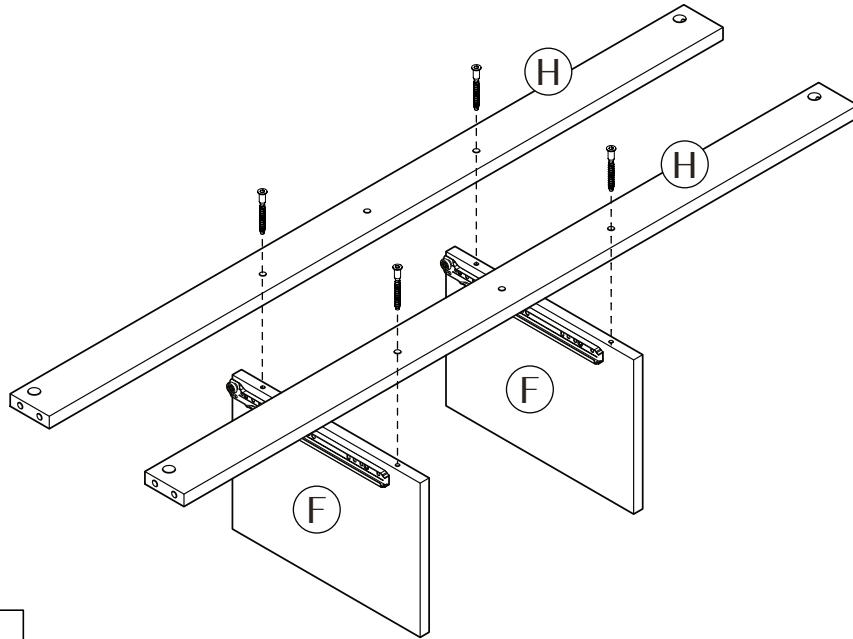
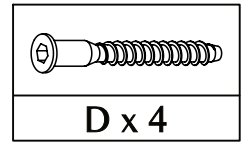

STEP 6

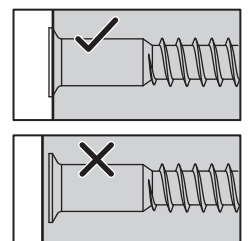
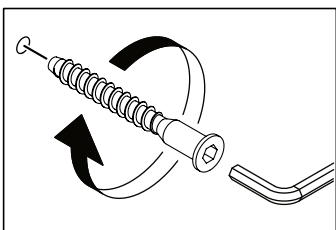
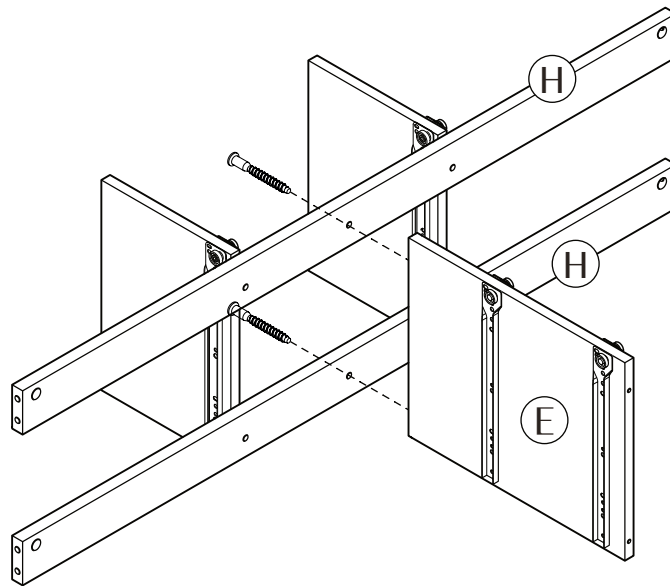
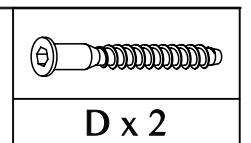

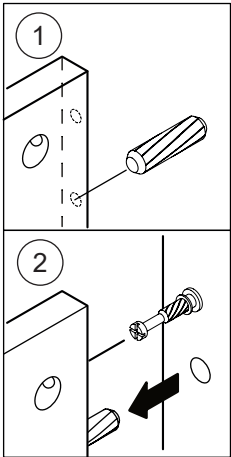
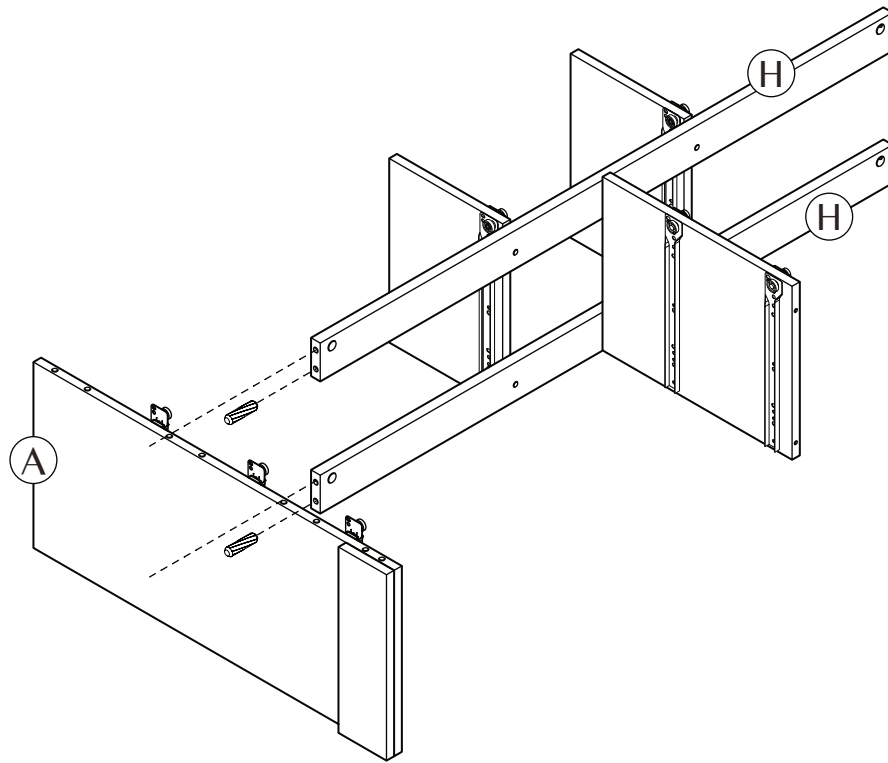
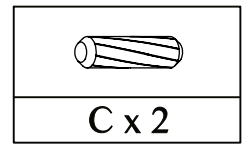

STEP 7

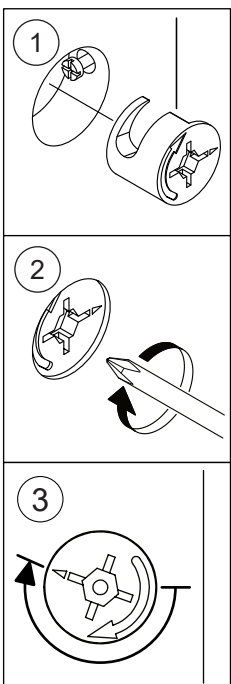
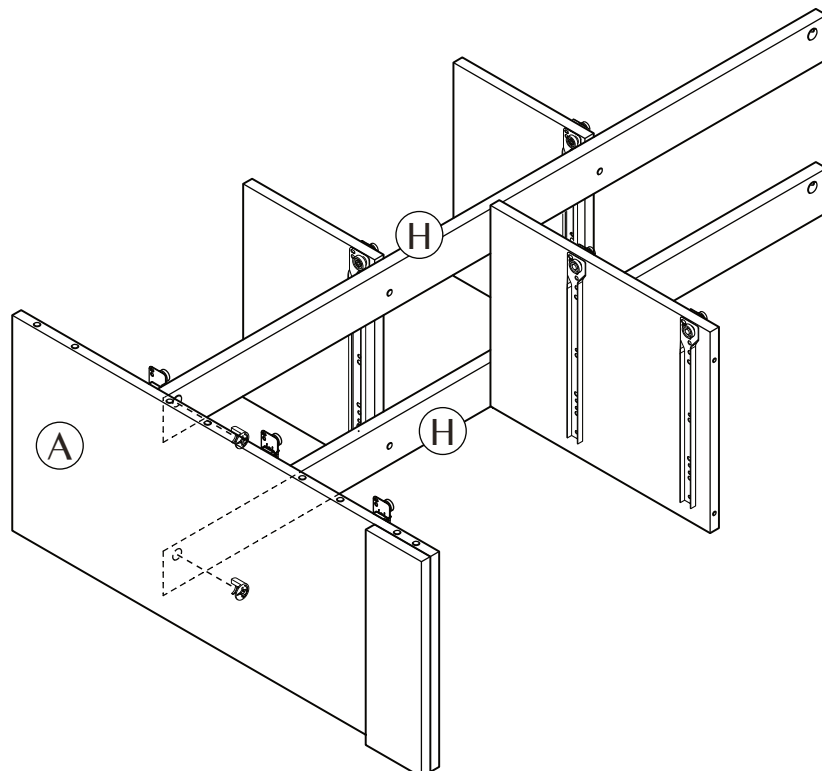
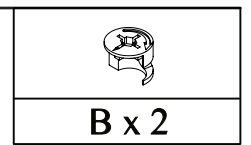

STEP 8



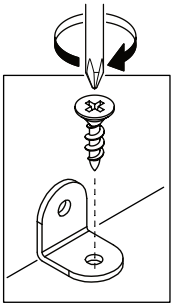
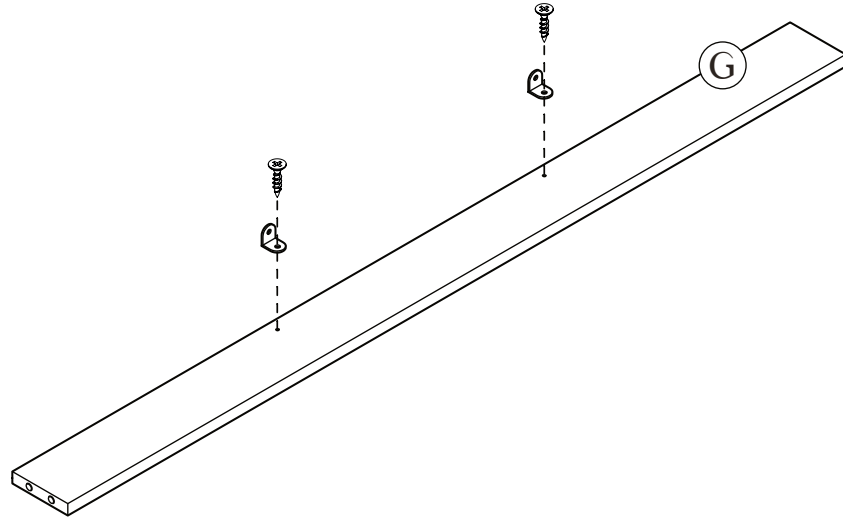

STEP 9

	
E x 2	R x 2

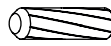

STEP 10

	
C x 3	E x 2

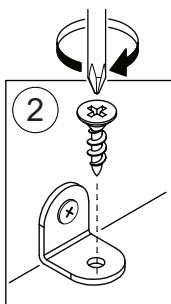
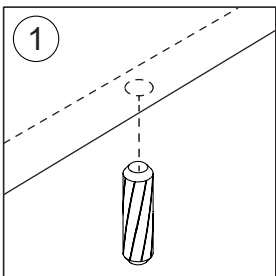
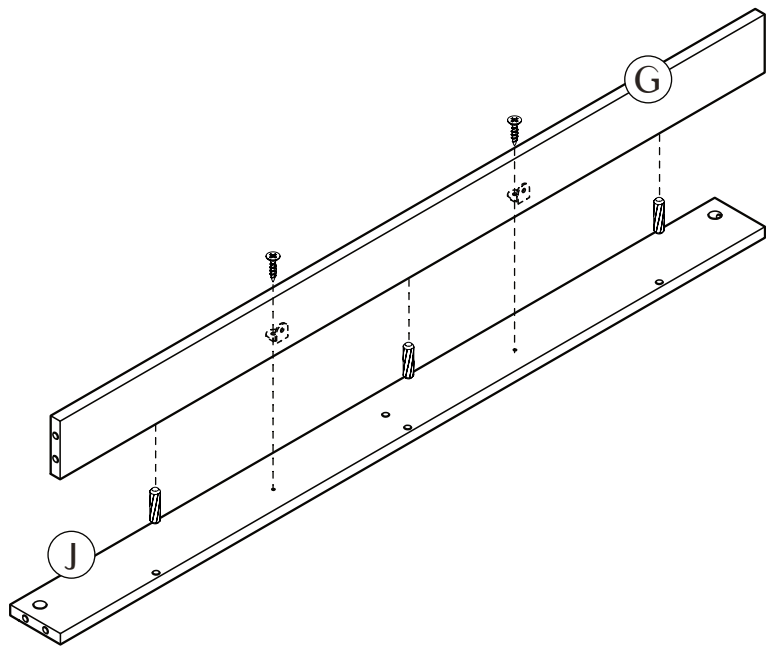

STEP 11

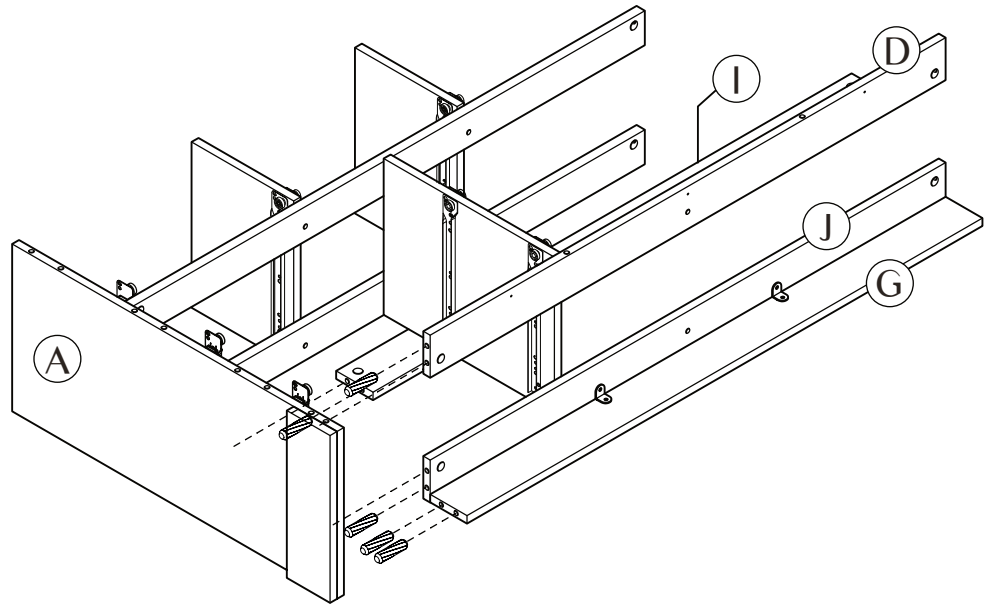
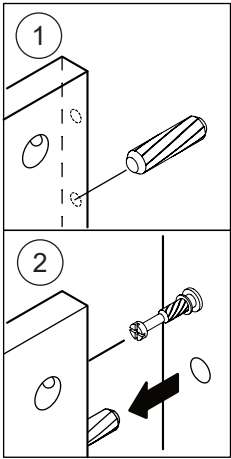
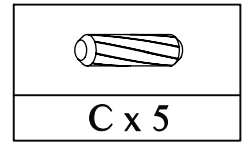

STEP 12

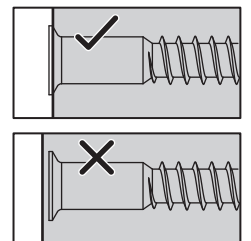
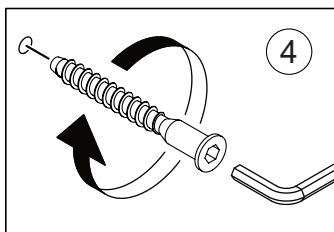
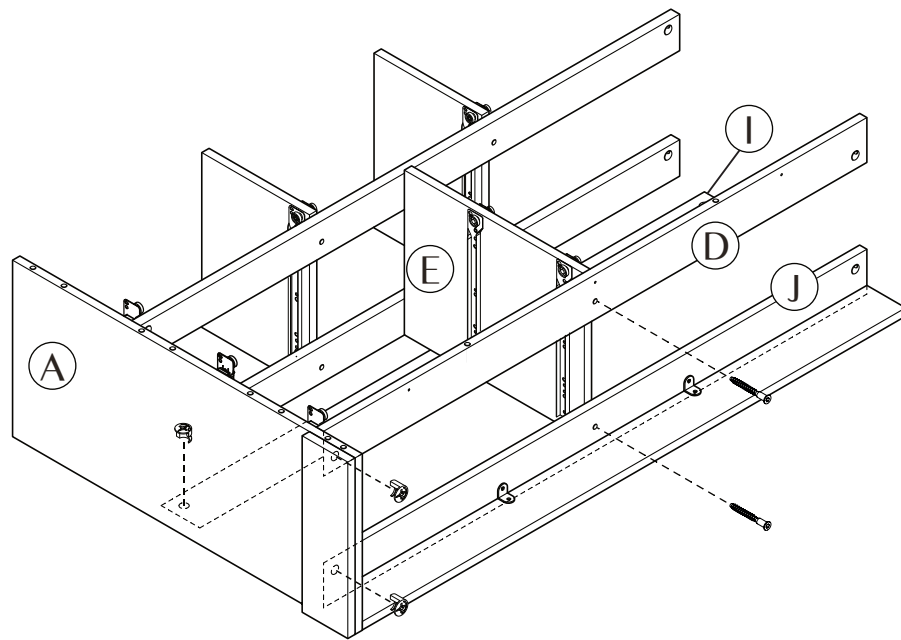
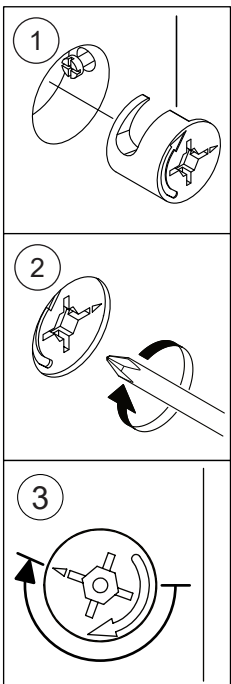
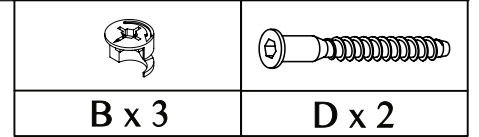

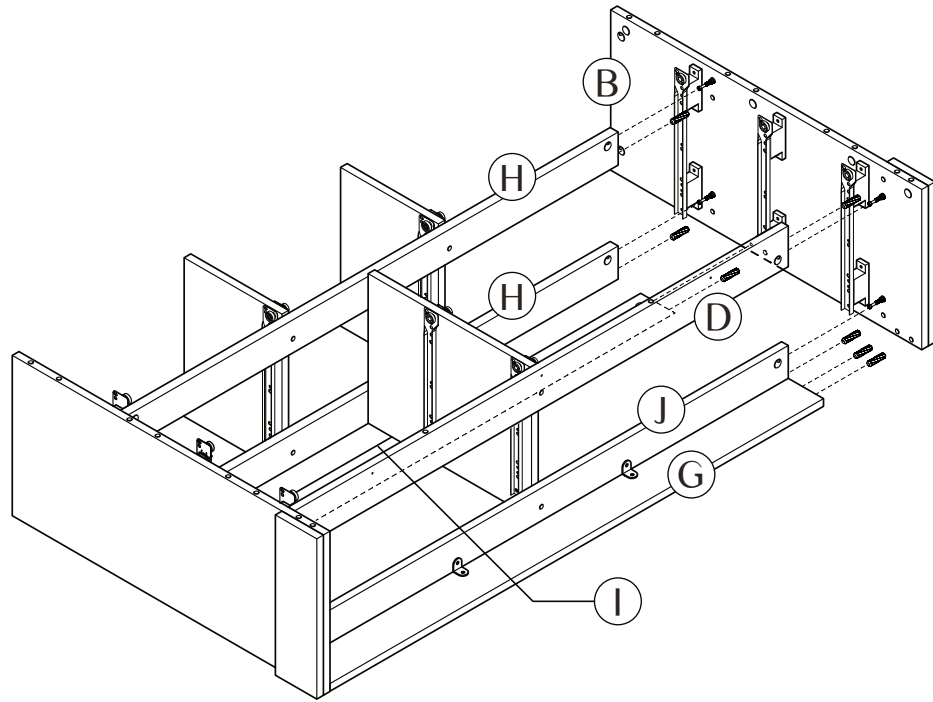
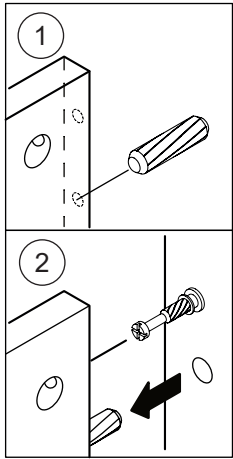
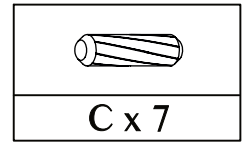

STEP 13

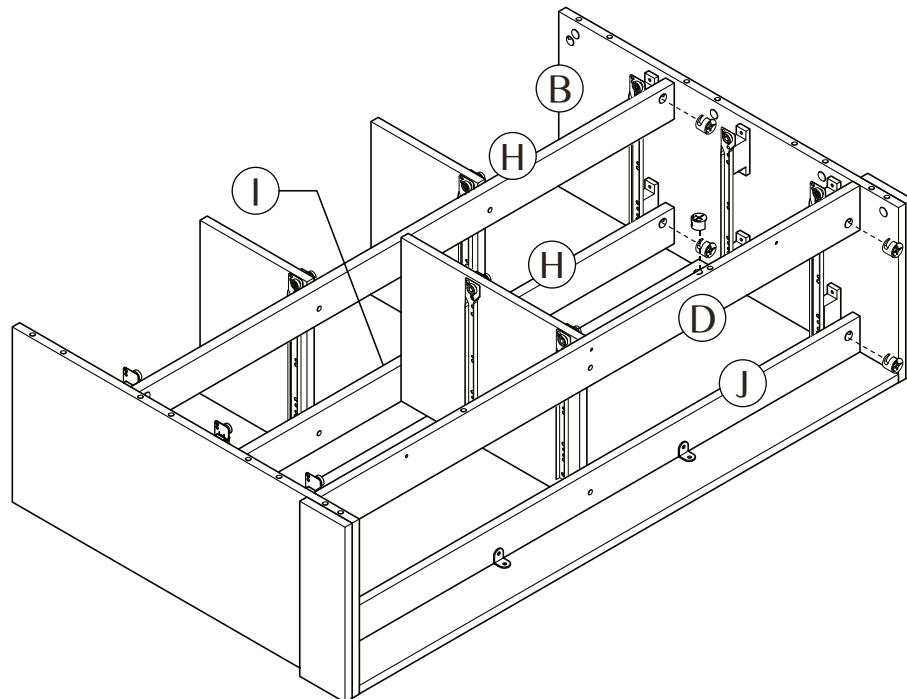
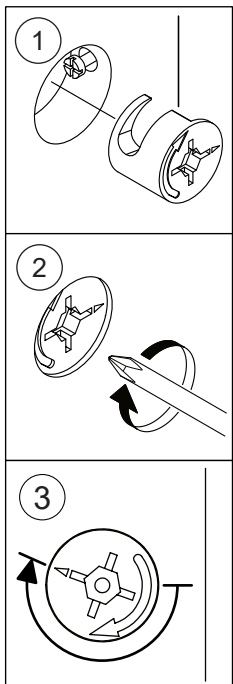
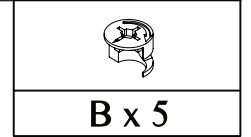

STEP 14



STEP 15

		
A x 8	E x 3	R x 3

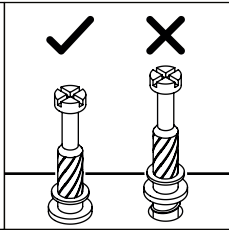
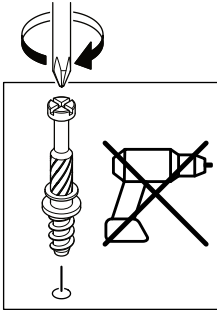
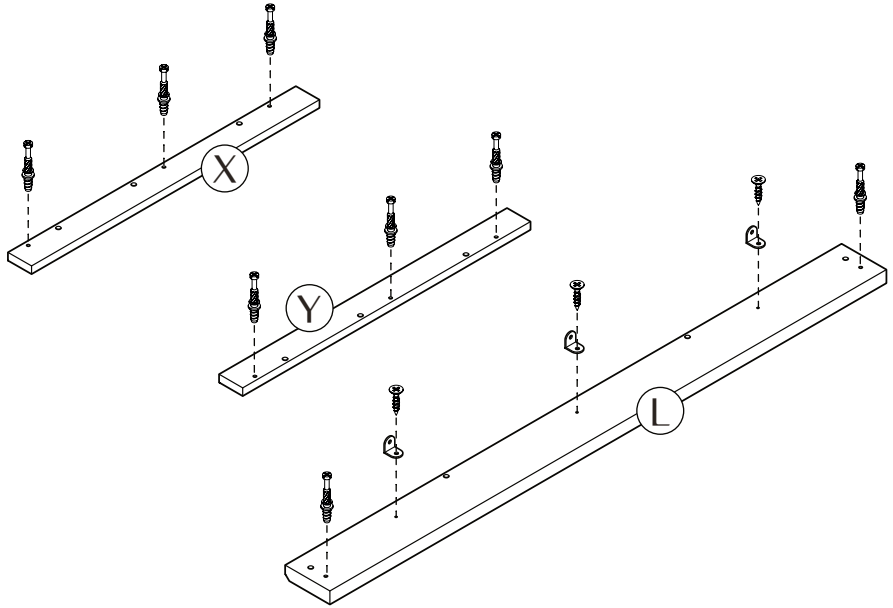

STEP 16

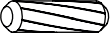

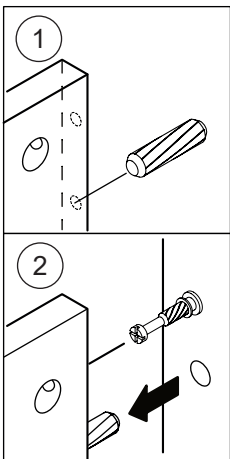
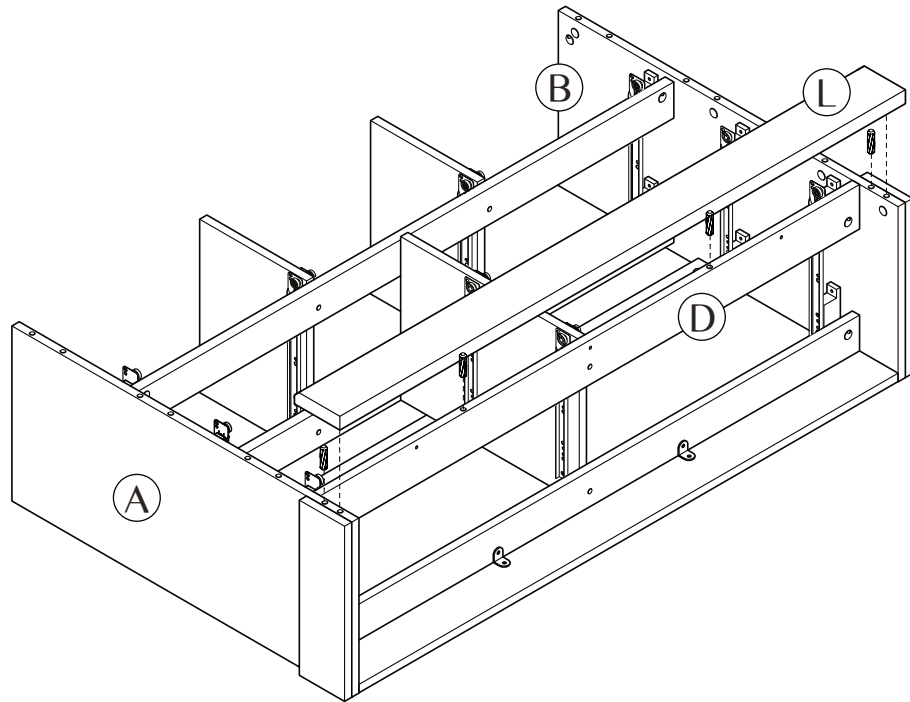
C x 4

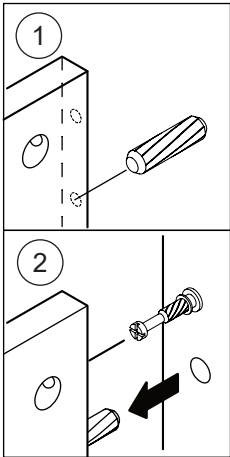
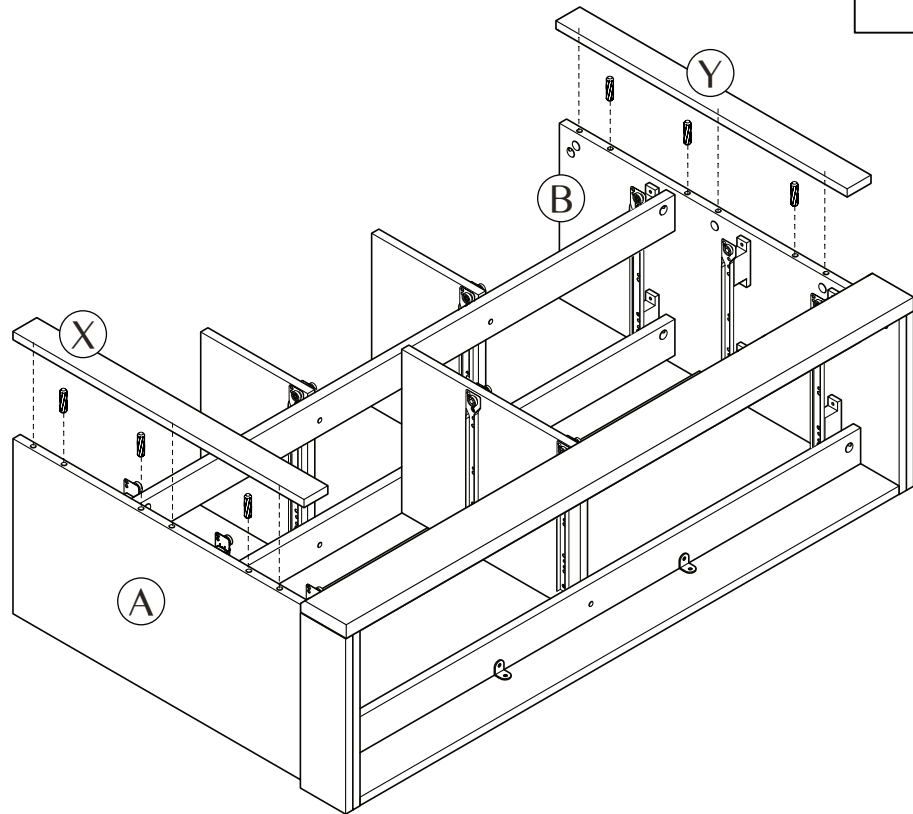
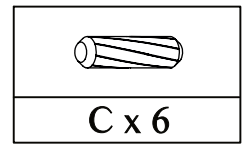

STEP 17

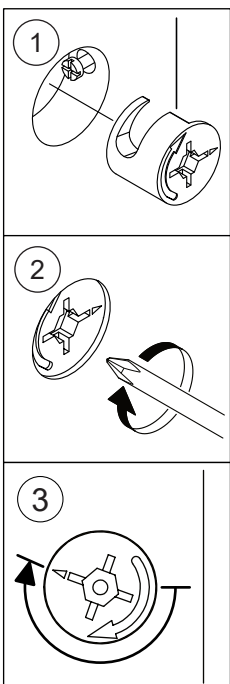
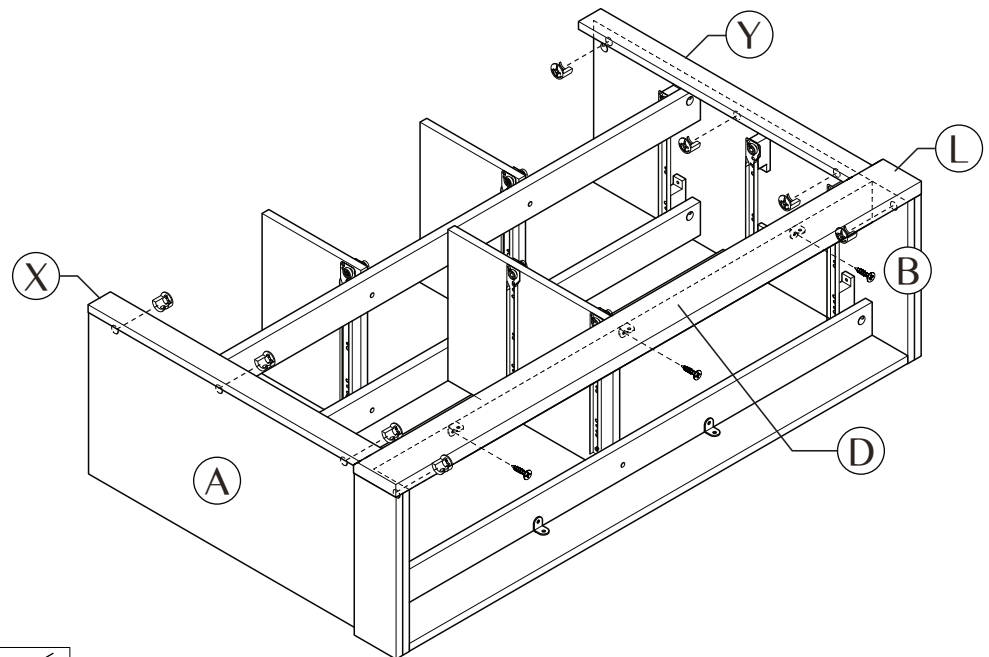
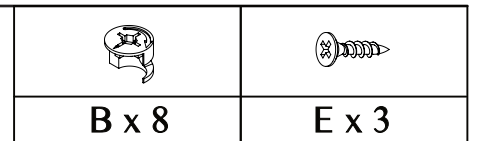

STEP 18



STEP 19

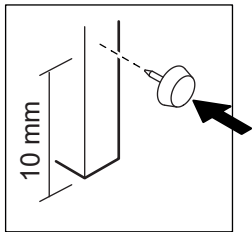
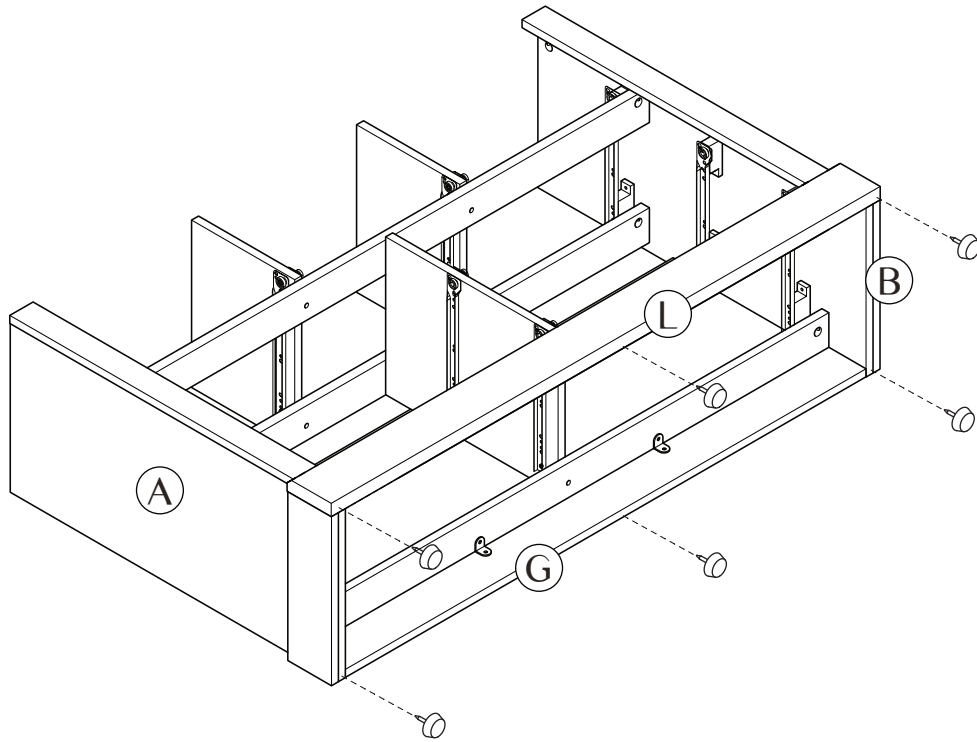
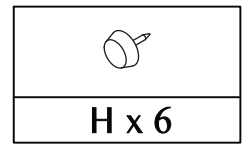

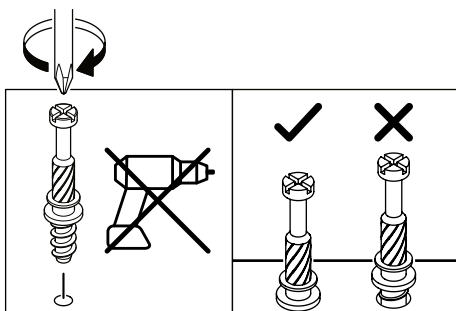
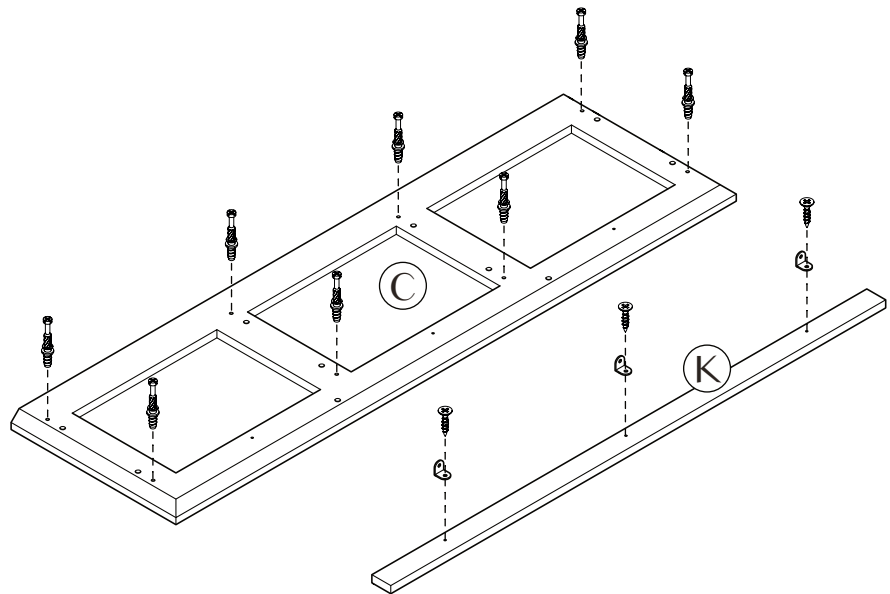
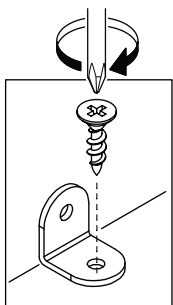

STEP 20

A x 8	E x 3	R x 3

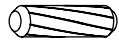

STEP 21

	
C x 2	E x 3

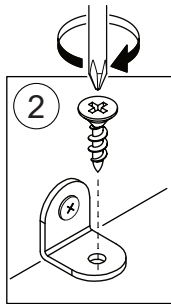
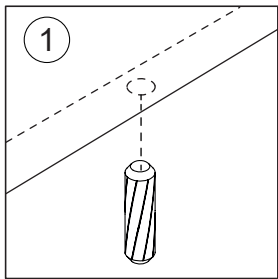
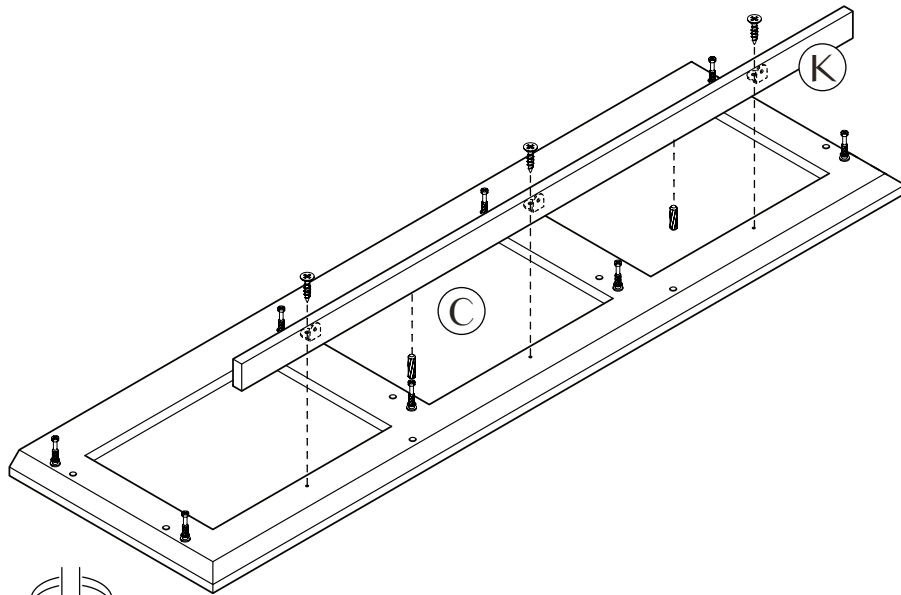

STEP 22

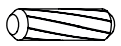

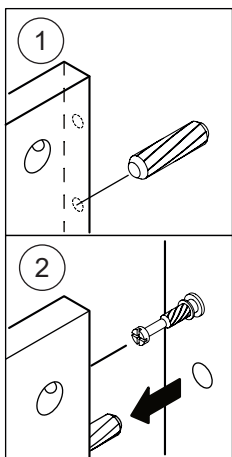
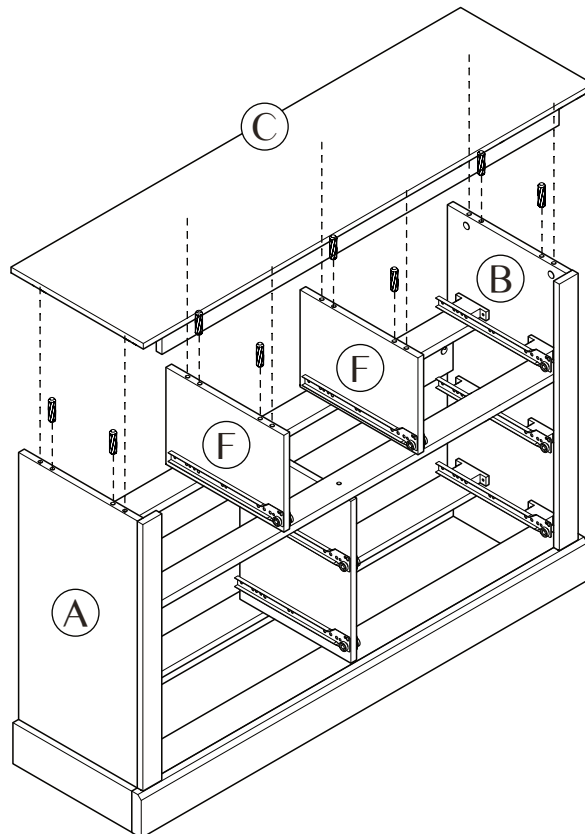
C x 8

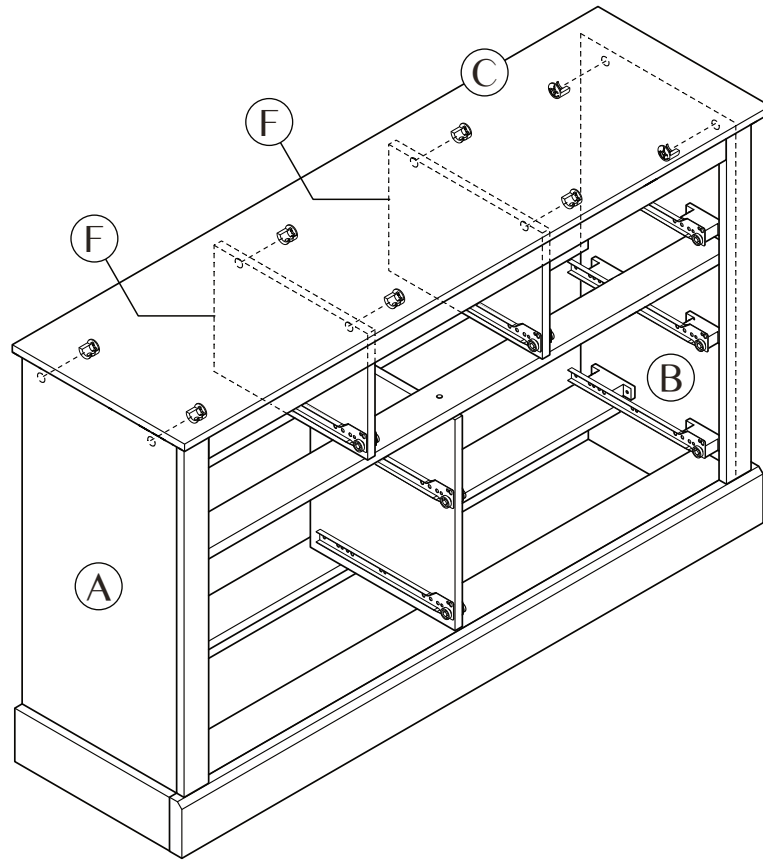
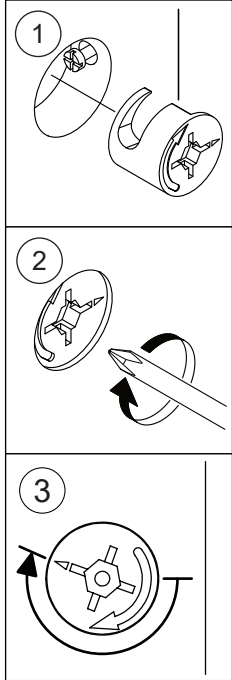
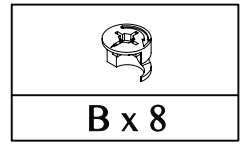

STEP 23

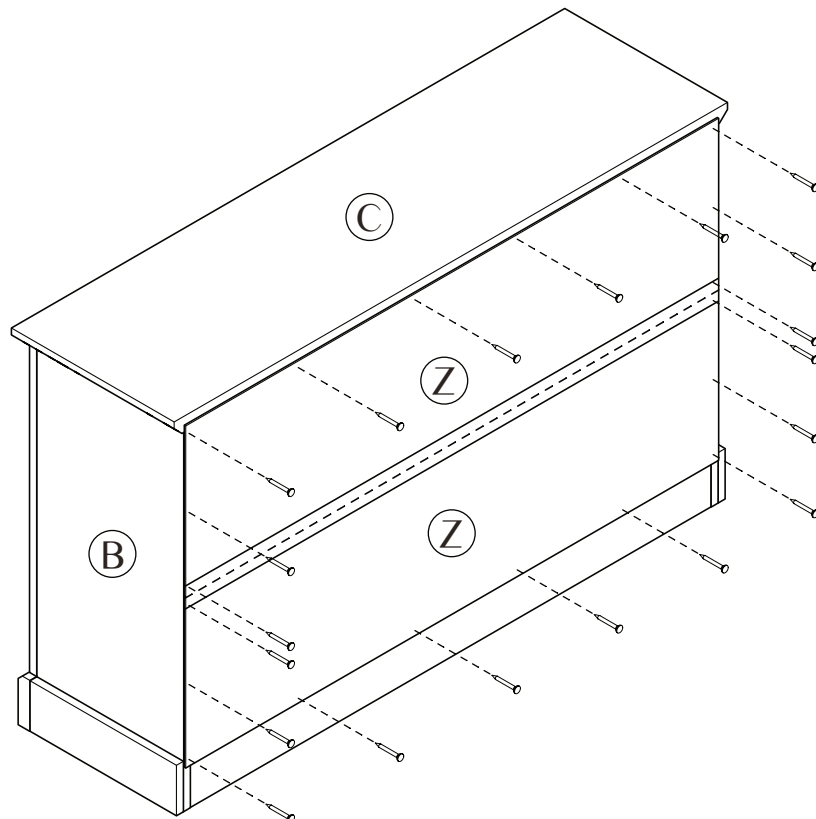
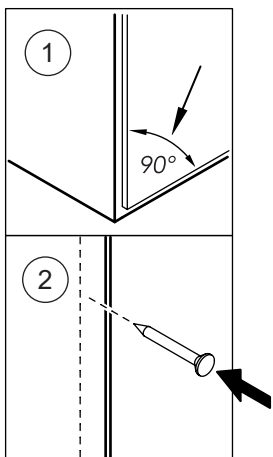
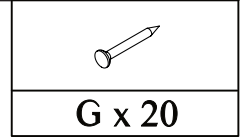

STEP 24



STEP 25



A x 14

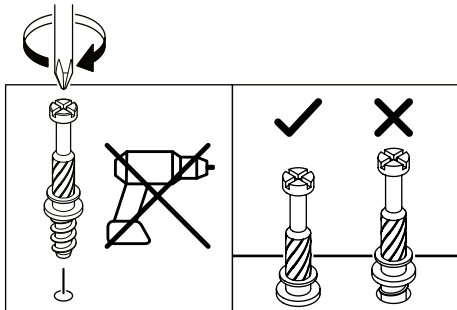
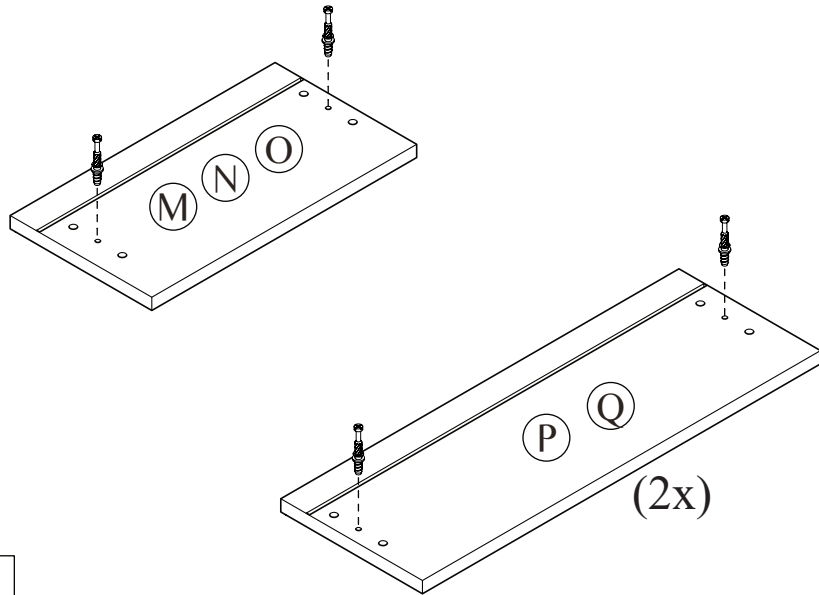

STEP 26

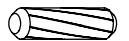

C x 28

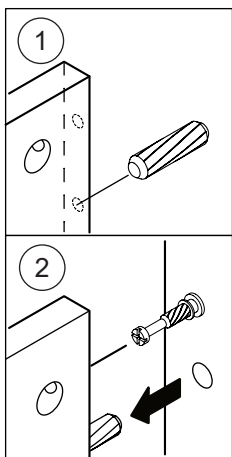
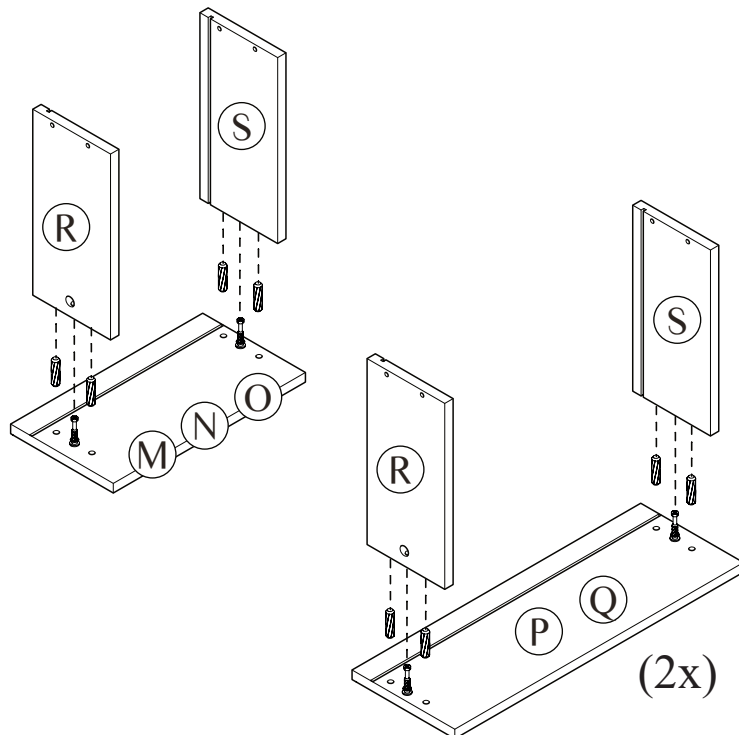

STEP 27

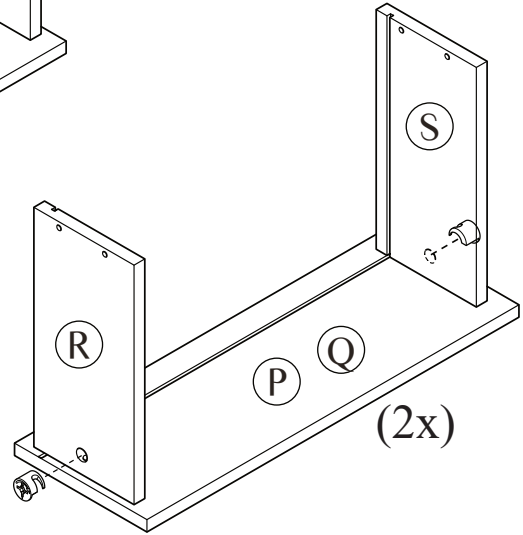
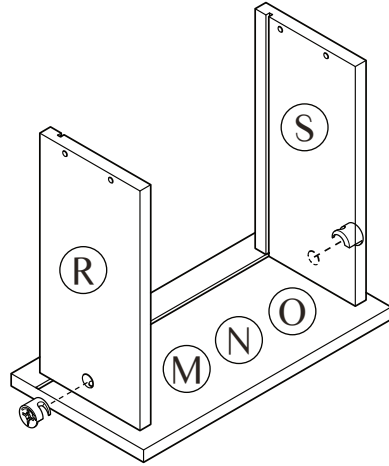
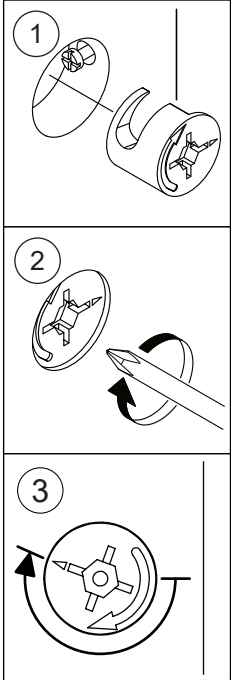
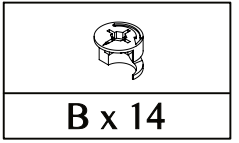

STEP 28

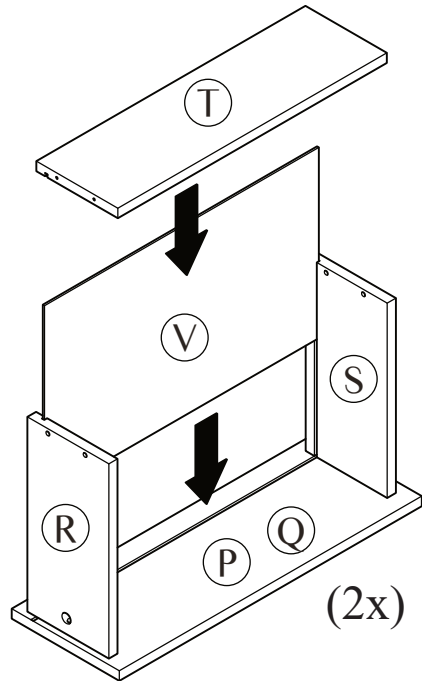
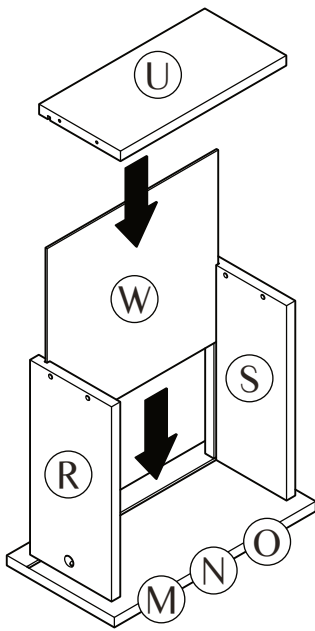

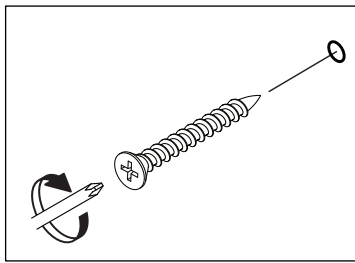
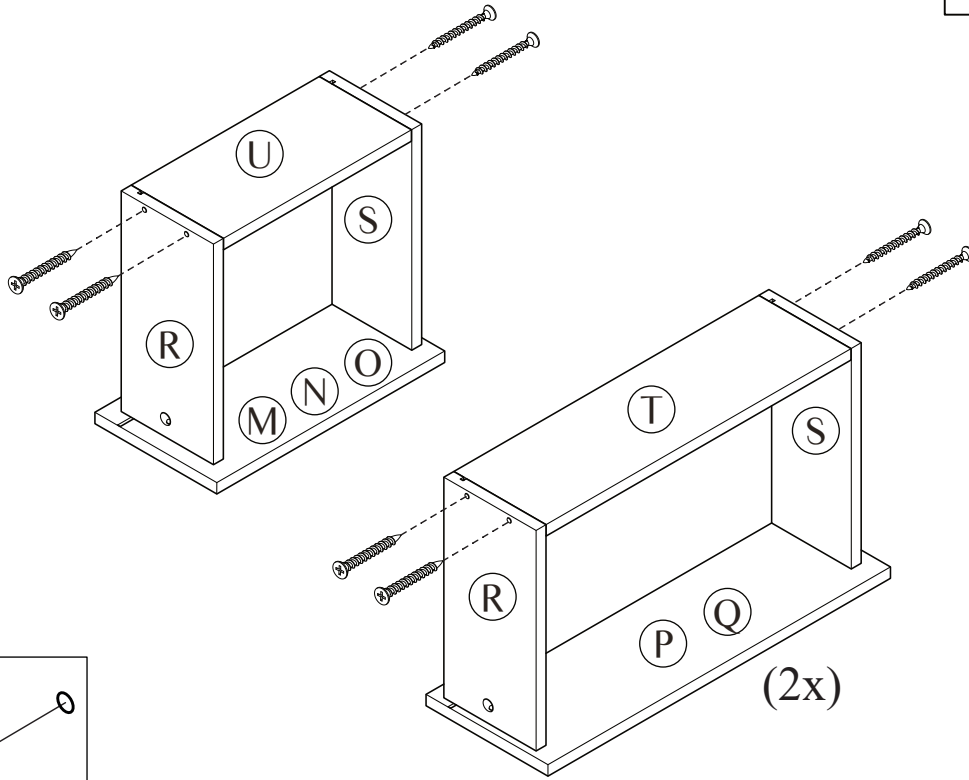
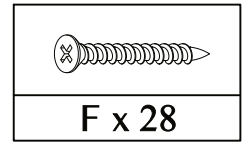

STEP 29

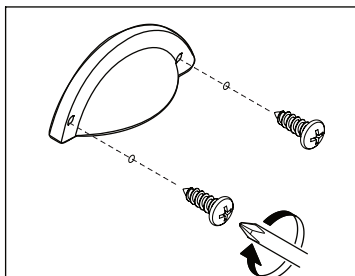
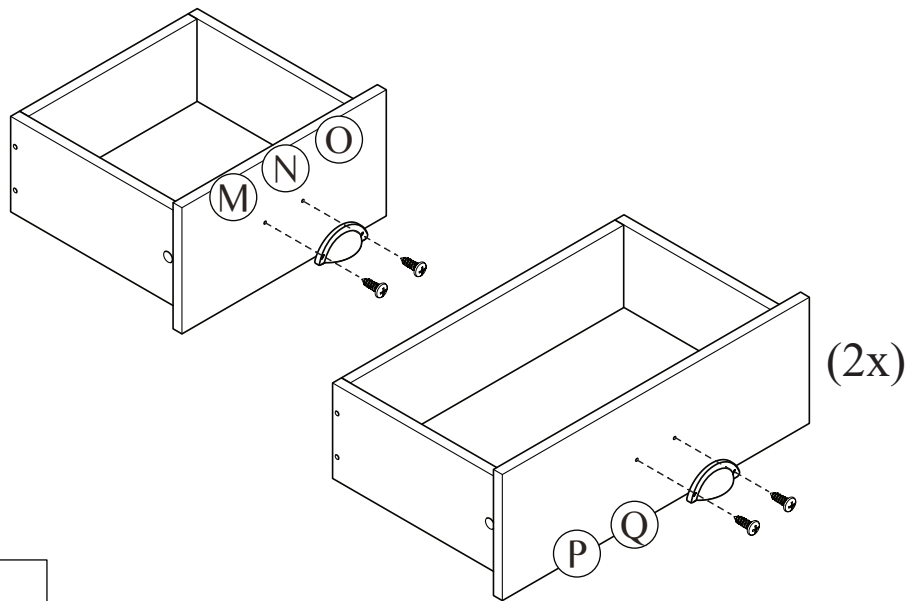
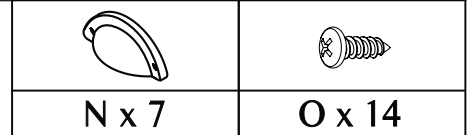

STEP 30



STEP 31

	
E x 28	Q x 7

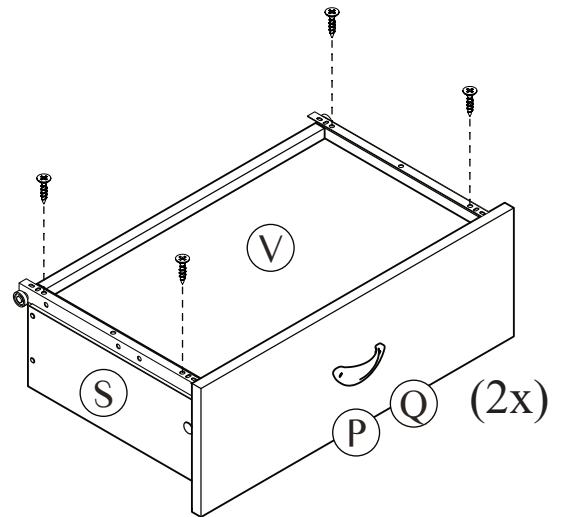
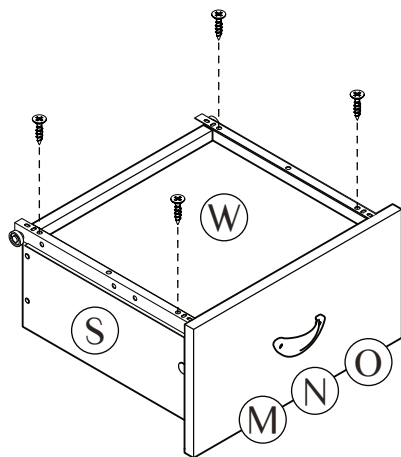
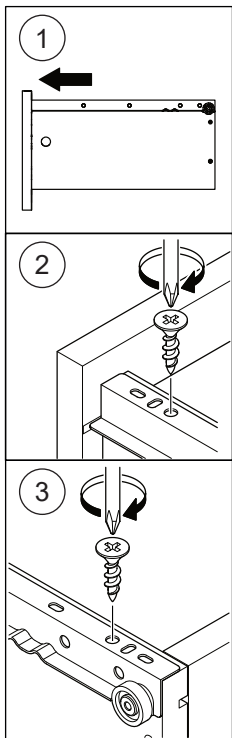

STEP 32

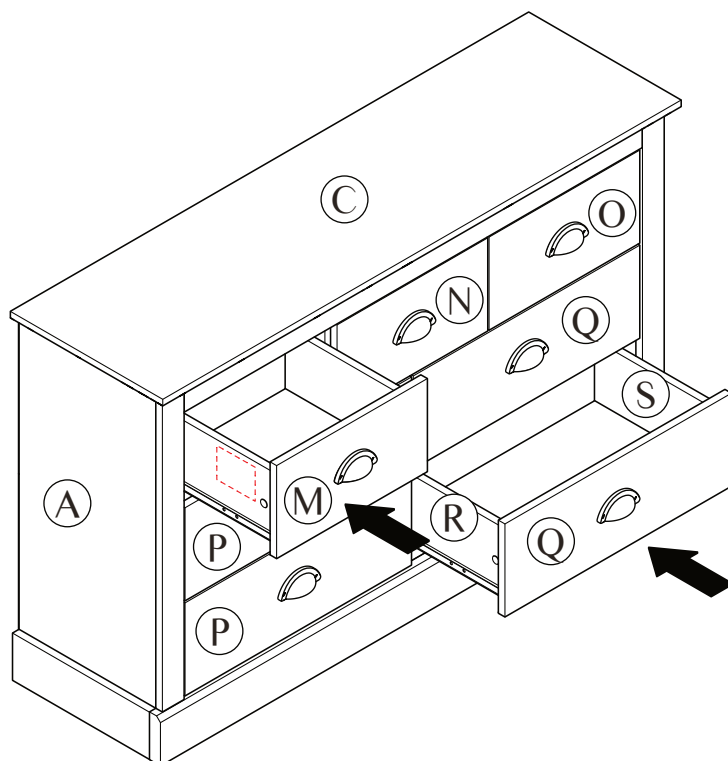
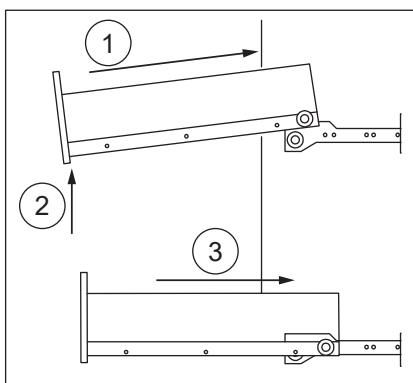

STEP 33

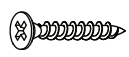
	
L x 1	M x 1

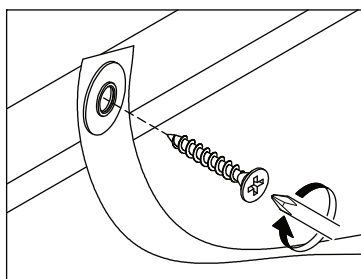
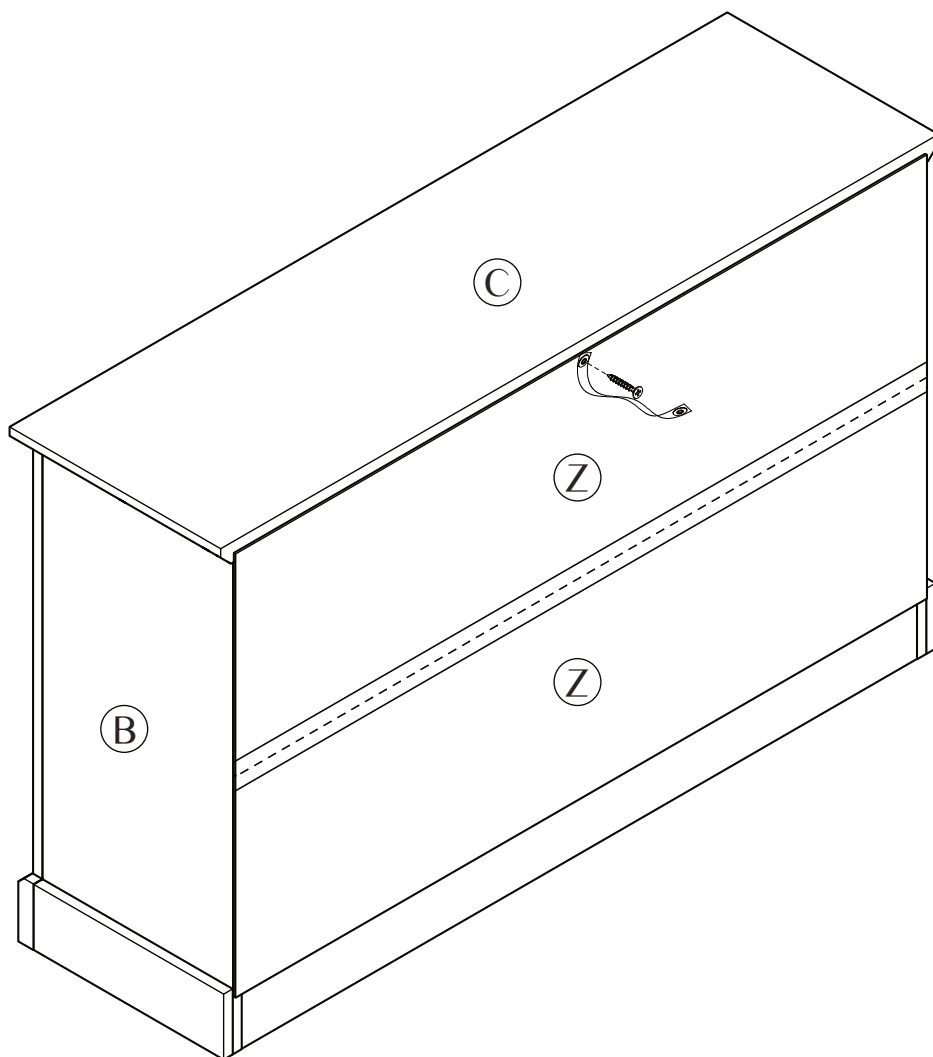

FITTING OF ANTI-TOPPLE SAFETY STRAP

MONTAGE DE LA SANGLE DE SÉCURITÉ ANTI-RENVERSEMENT

COLOCACIÓN CORREA DE SEGURIDAD ANTI-TOPPLE

STEP 1:

Fix screw through safety strap hole on the top panel of your furniture.

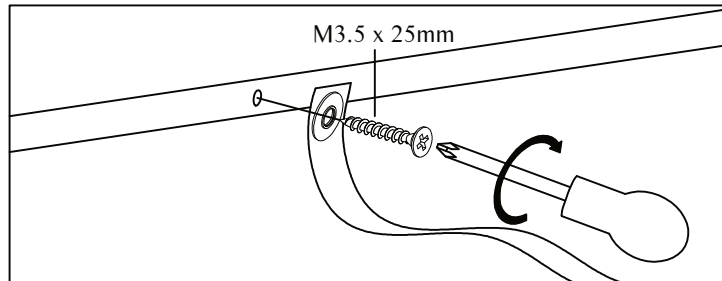

STEP 2:

Drill a hole on the wall and insert the wall plug.

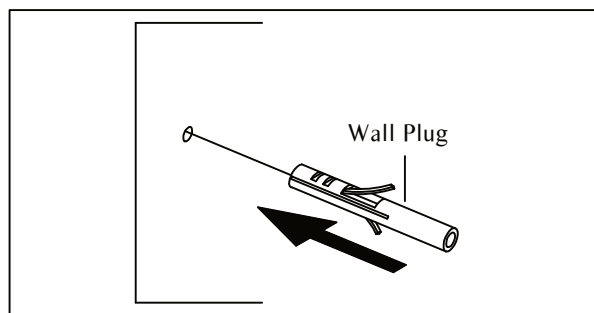

STEP 3:

Fix screw through the safety strap in the wall plug hole.

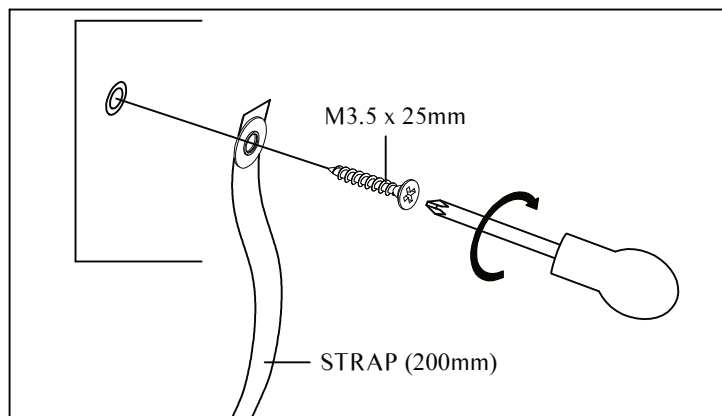

NOTE: Wall fixings are not supplied with this product as different wall materials require different types of fixing devices (such as Rawl plugs on bricks wall). You must use fixing devices suitable for the type of wall you intend to mount this product to. Please ensure that the head of any screw used has a diameter greater than the diameter of the mounting hole on the product and that the fixing is safe and secure before use.

The straps and screws which to fix the strap on to the furniture are provided only.

HARDWARE LIST



STRAP (200mm) - 1 Pc

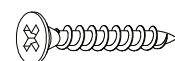

M3.5 x 25mm - 1 Pc

MAXIMUM LOADS CHARGES MAXIMALES / CARGA MAXIMA

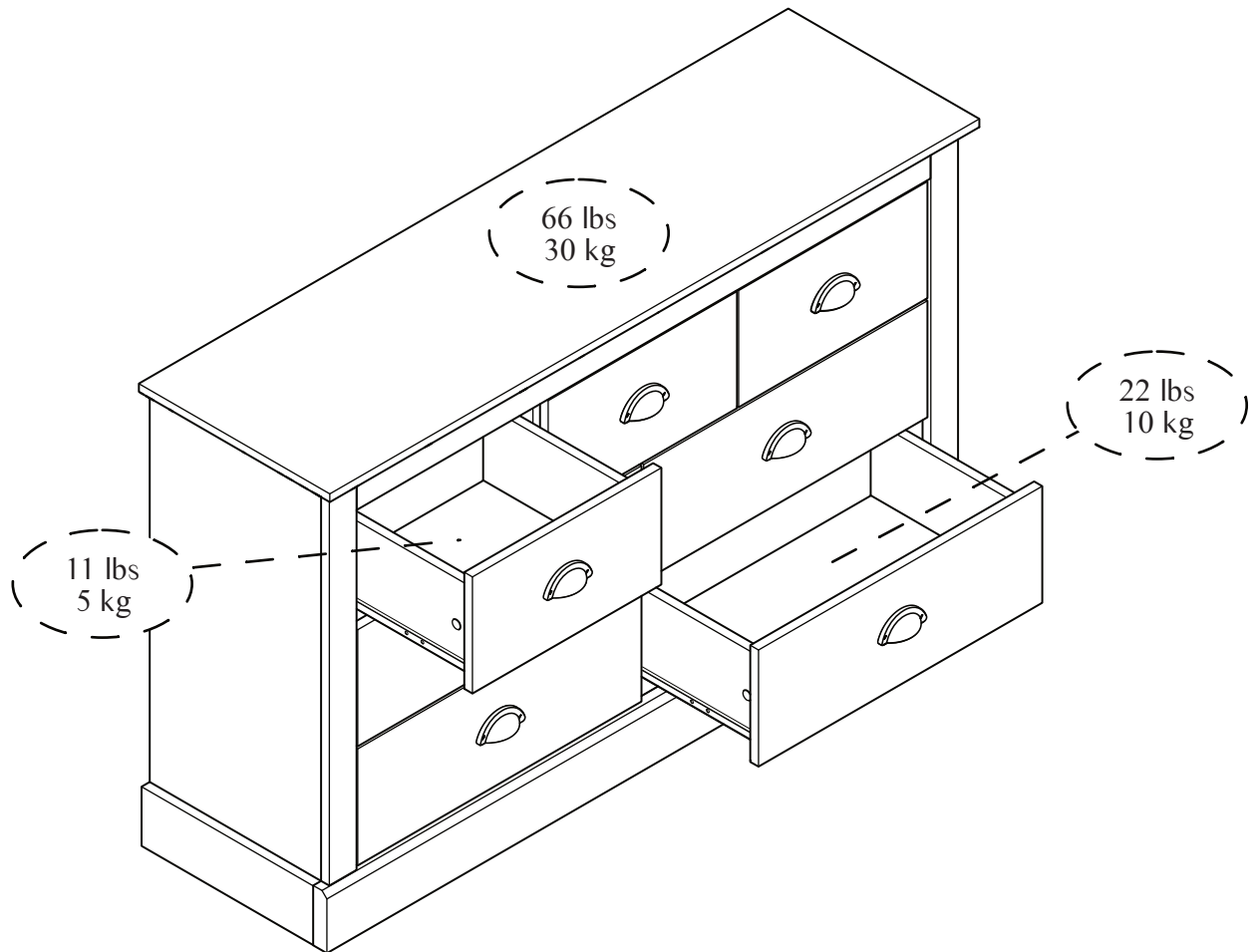

This unit has been designed to support the maximum loads shown. Exceeding these load limits could cause sagging, instability, product collapse, and/or serious injury.

Ce meuble a été conçu pour supporter les charges maximales indiquées. En excédant ces limites de charge, le meuble pourrait devenir instable, s'effondrer, et/ou causer des blessures graves.

Esta unidad ha sido diseñada para soportar la carga máxima anotada. El exceder estos límites puede causar inestabilidad, colapsarse y/o causar serias lesiones.
