

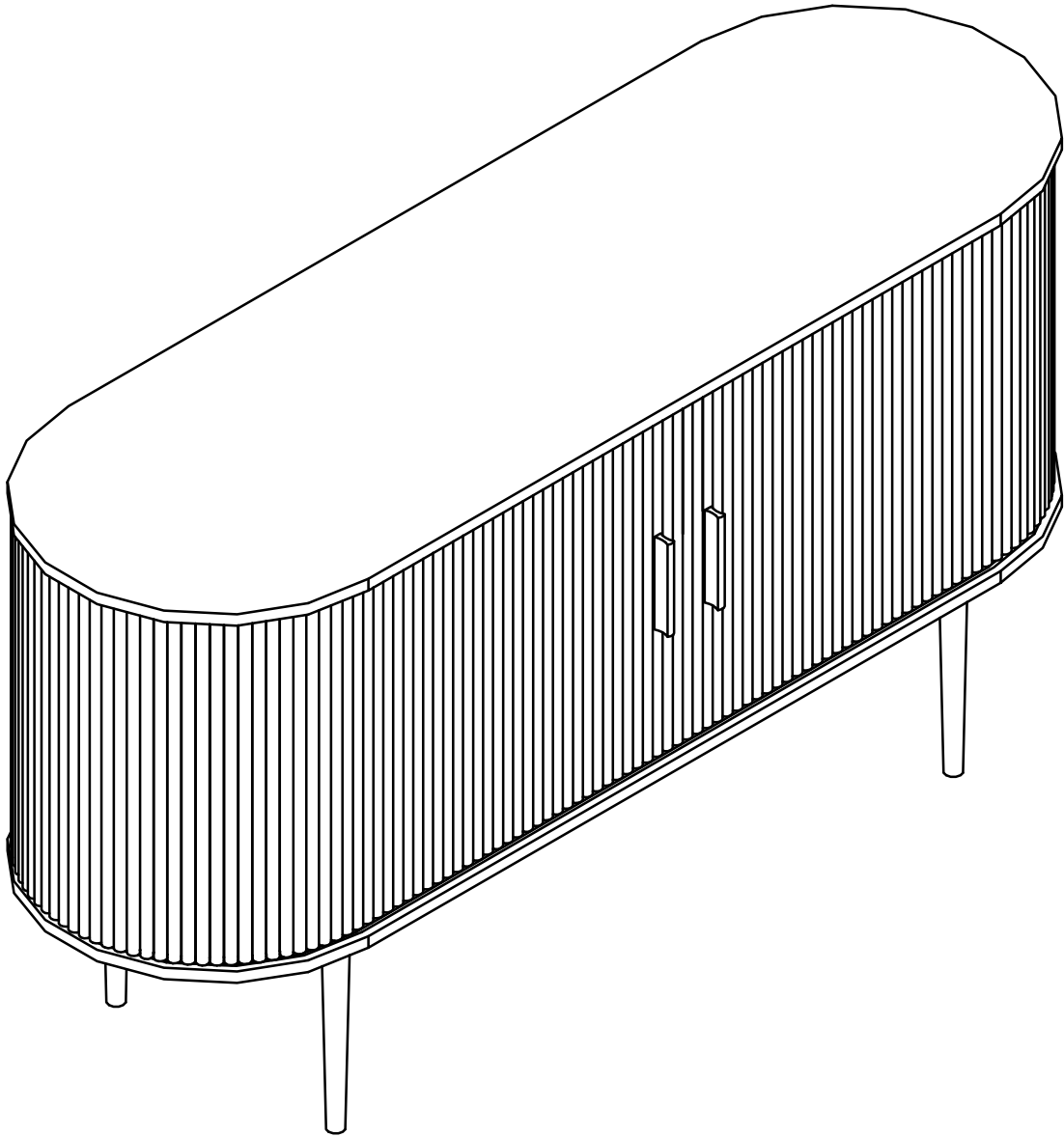

Assembly Instruction

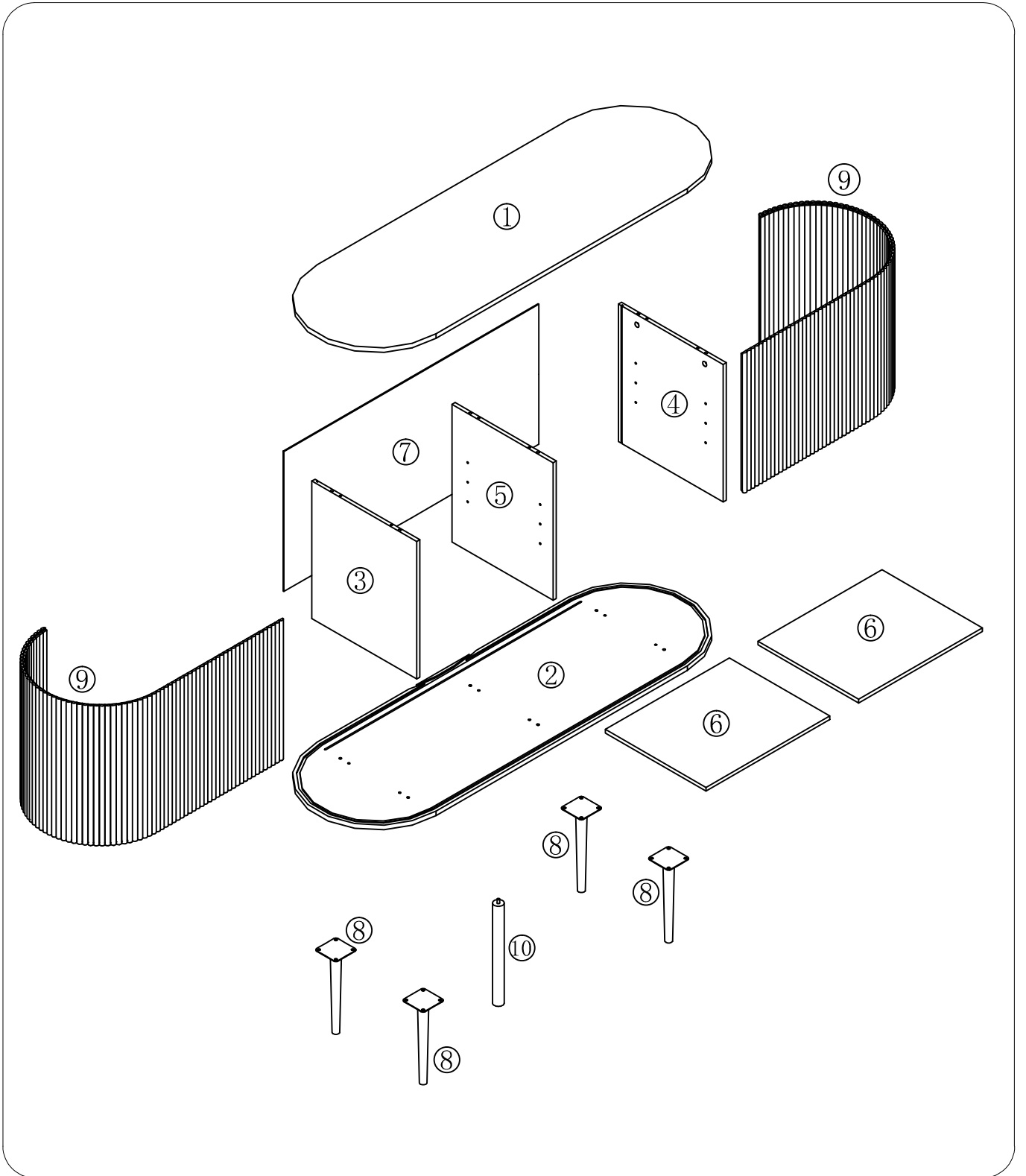

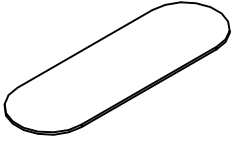

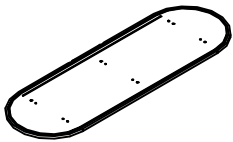
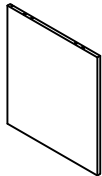
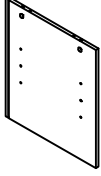
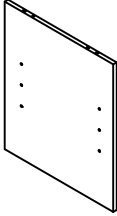
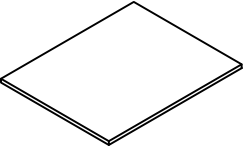
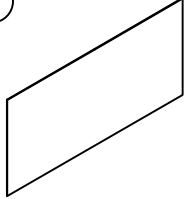
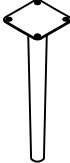
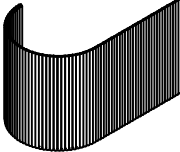





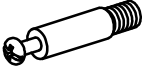

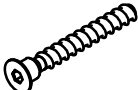

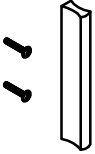
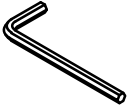
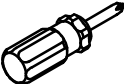

HARDWARE LIST

<p>①</p>  <p>1PC</p>	<p>②</p>  <p>1PC</p>	<p>③</p>  <p>1PC</p>	<p>④</p>  <p>1PC</p>	<p>⑤</p>  <p>1PC</p>
<p>⑥</p>  <p>2PC</p>	<p>⑦</p>  <p>1PC</p>	<p>⑧</p>  <p>4PC</p>	<p>⑨</p>  <p>2PC</p>	<p>⑩</p>  <p>1PC</p>

HARDWARE LIST

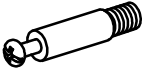
<p>A</p>  <p>Ø3.5x19mm 3PCS</p>	<p>B</p>  <p>6x40mm 6PCS</p>	<p>C</p>  <p>Ø15*12mm 6PCS</p>	<p>D</p>  <p>8x30mm 12PCS</p>	<p>E</p>  <p>M6x50mm 6PCS</p>
<p>F</p>  <p>6PCS</p>	<p>G</p>  <p>9PCS</p>	<p>H</p>  <p>M6x10mm 16PCS</p>	<p>I</p>  <p>2PCS</p>	<p>J</p>  <p>1PCS</p>
<p>K</p>  <p>1PCS</p>	<p>L</p>  <p>2PCS</p>			

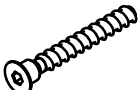
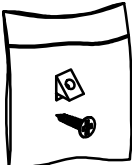
HARDWARE SPARE LIST

<p>A</p>  <p>M8x19mm 1PCS</p>	<p>B</p>  <p>6x40mm 1PCS</p>	<p>C</p>  <p>Ø15*9mm 1PCS</p>	<p>D</p>  <p>8x30mm 1PCS</p>	<p>E</p>  <p>M6x50mm 1PCS</p>
<p>F</p>  <p>1PCS</p>	<p>G</p>  <p>1PCS</p>	<p>H</p>  <p>M6x10mm 1PCS</p>		

This furniture requires two people to assemble and move.
 Make sure no parts missing or damaged before assembly.

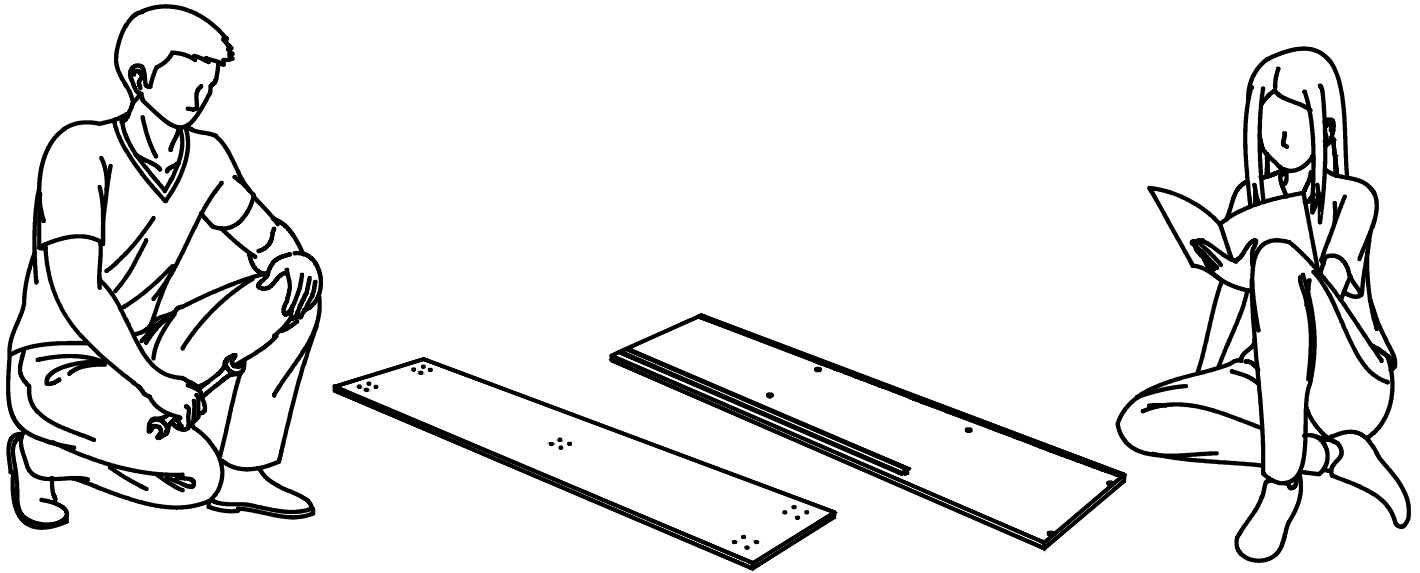

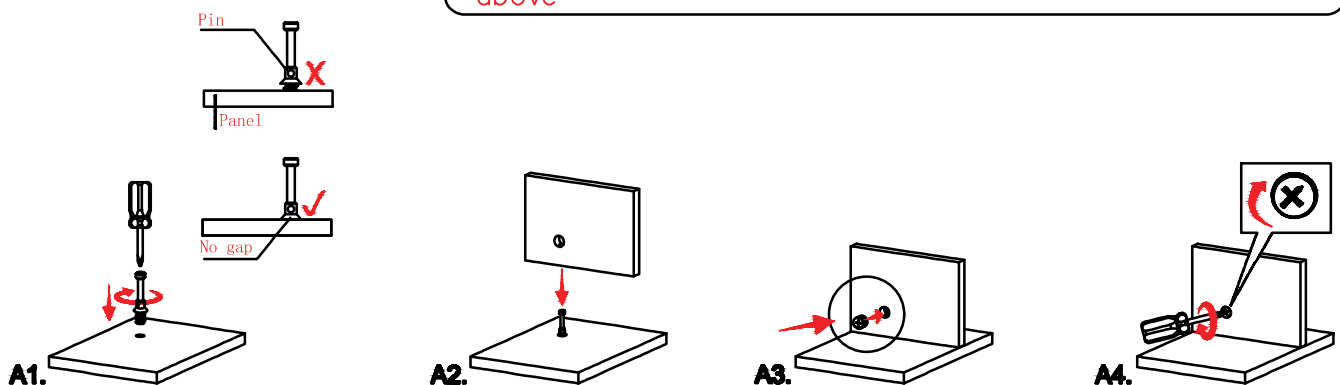
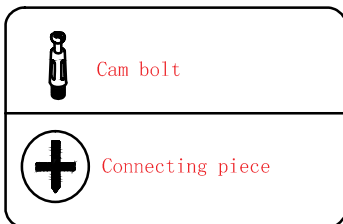

CAM BOLT INSTALLATION AS BELOW





STEPS

STEP-1

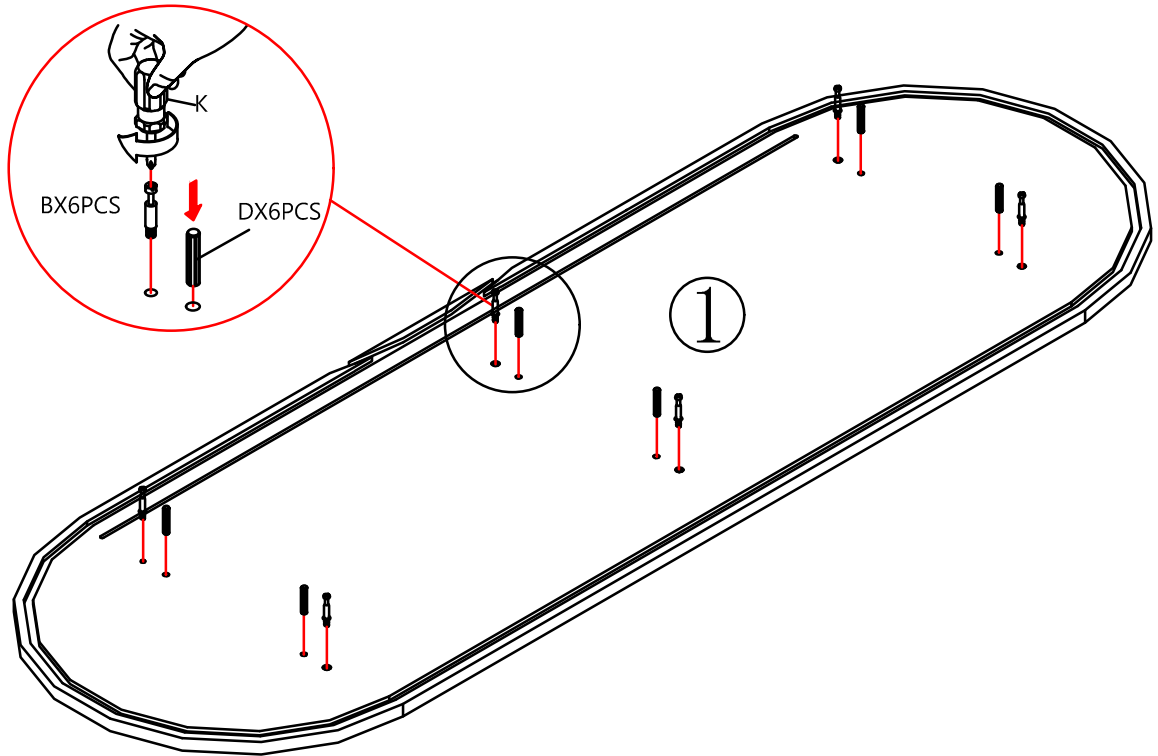
	B x6PCS		D x6PCS
	K x1PCS		



STEP-2

	C x6PCS
	K x1PCS

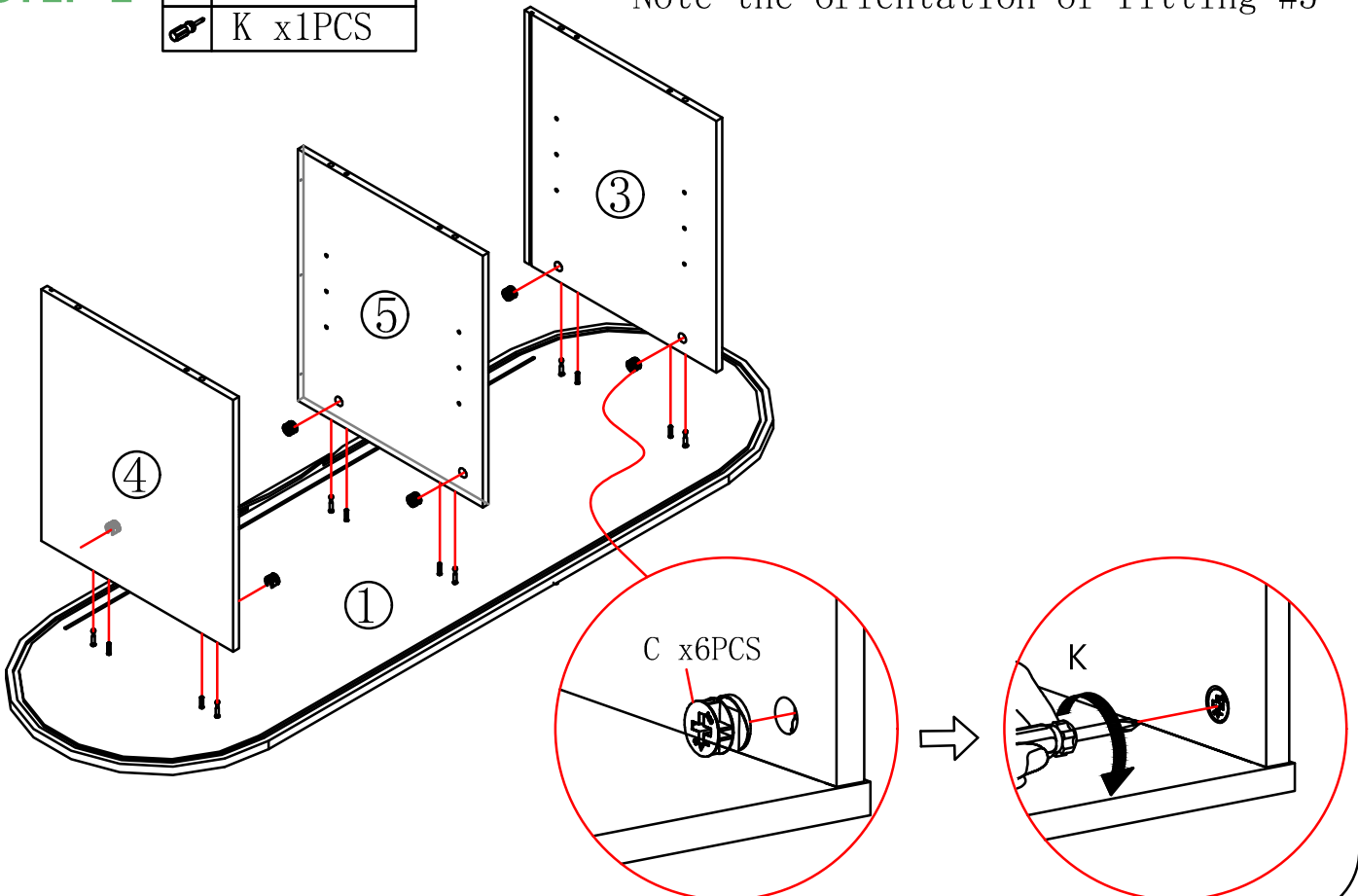

Note the orientation of fitting #5

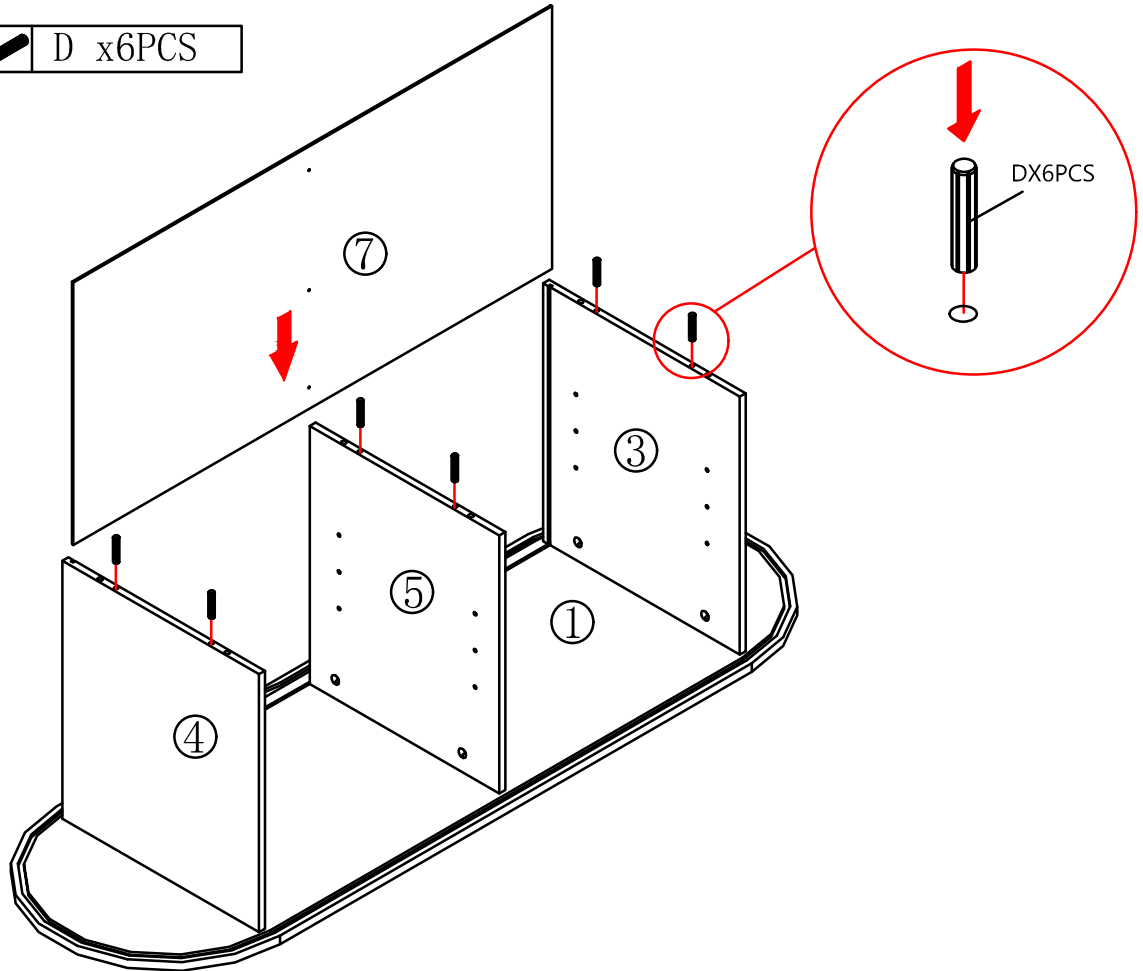

STEPS

STEP-3  D x6PCS



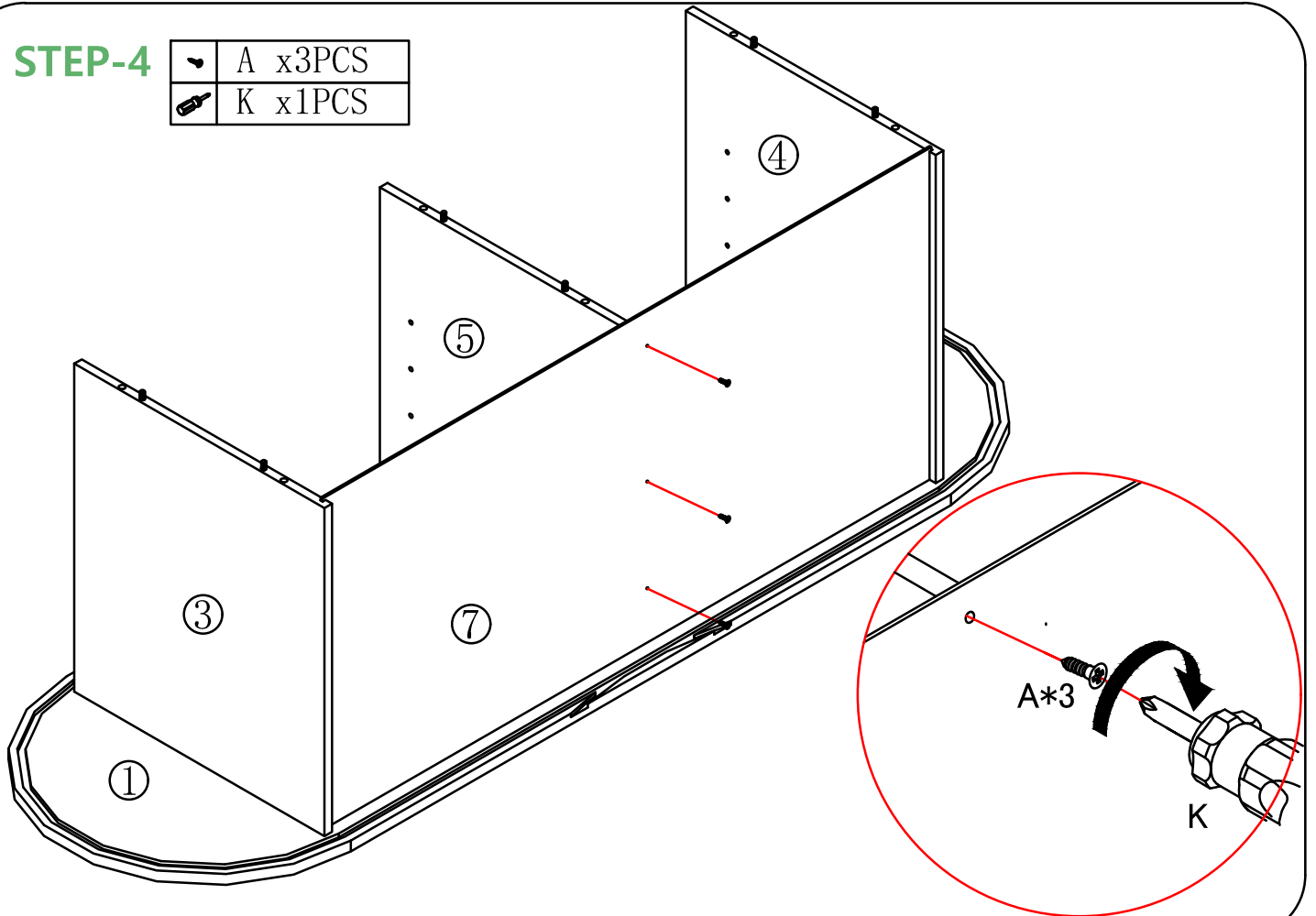

STEP-4  A x3PCS
 K x1PCS





STEPS

STEP-5

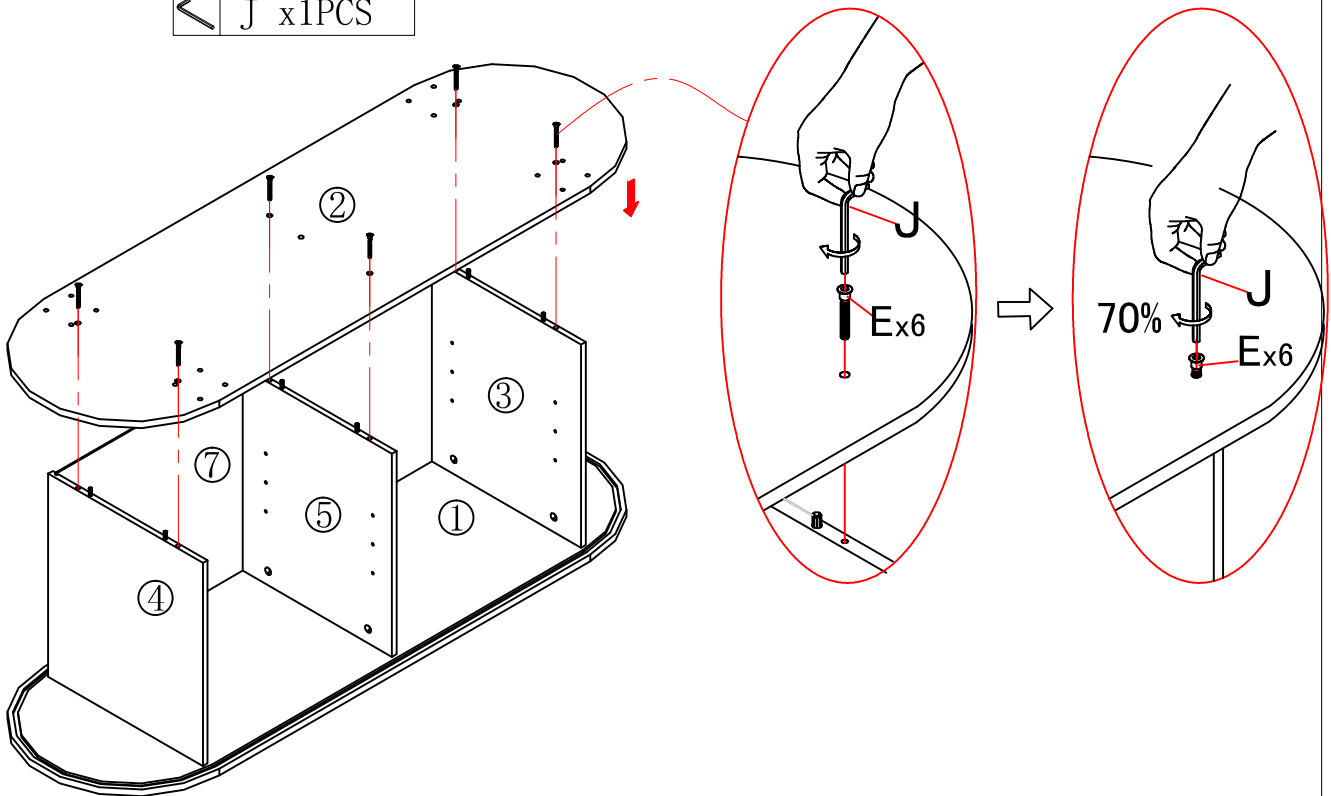
	E x6PCS
	J x1PCS



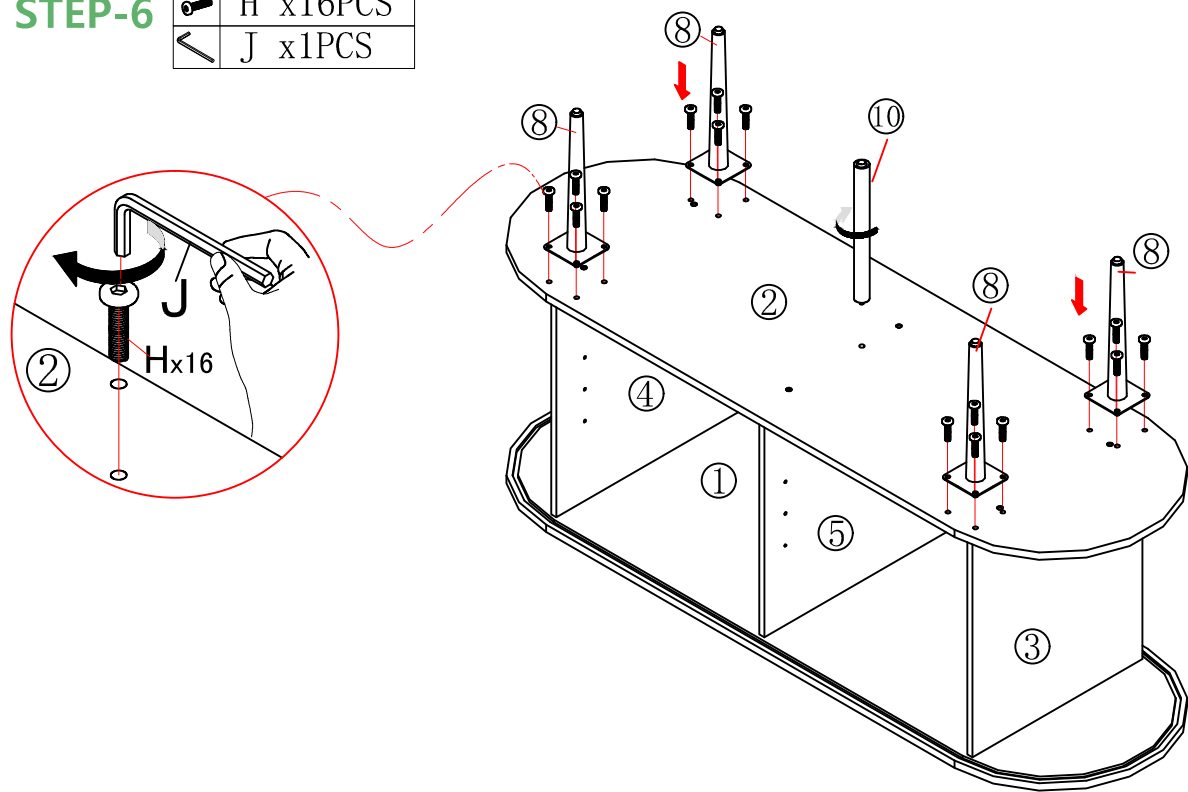

STEP-6

	H x16PCS
	J x1PCS



STEPS

STEP-7

	K x1PCS
	I x2PCS

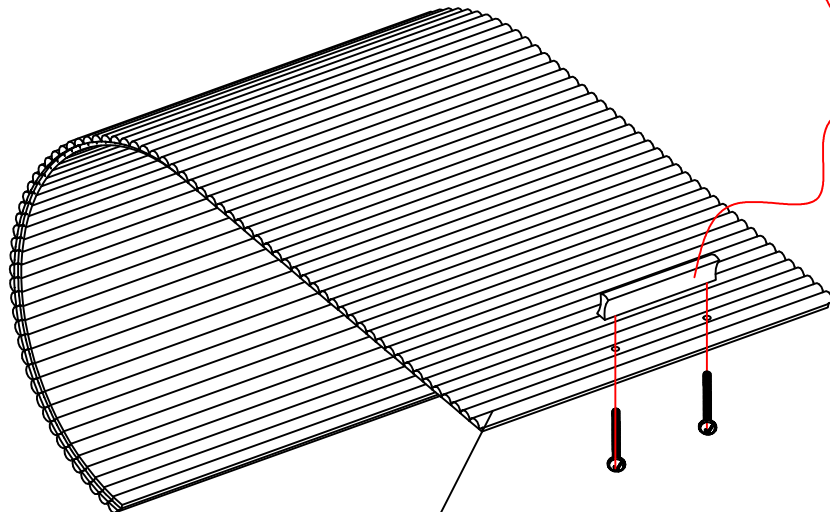

X2

⑨

STEP-8

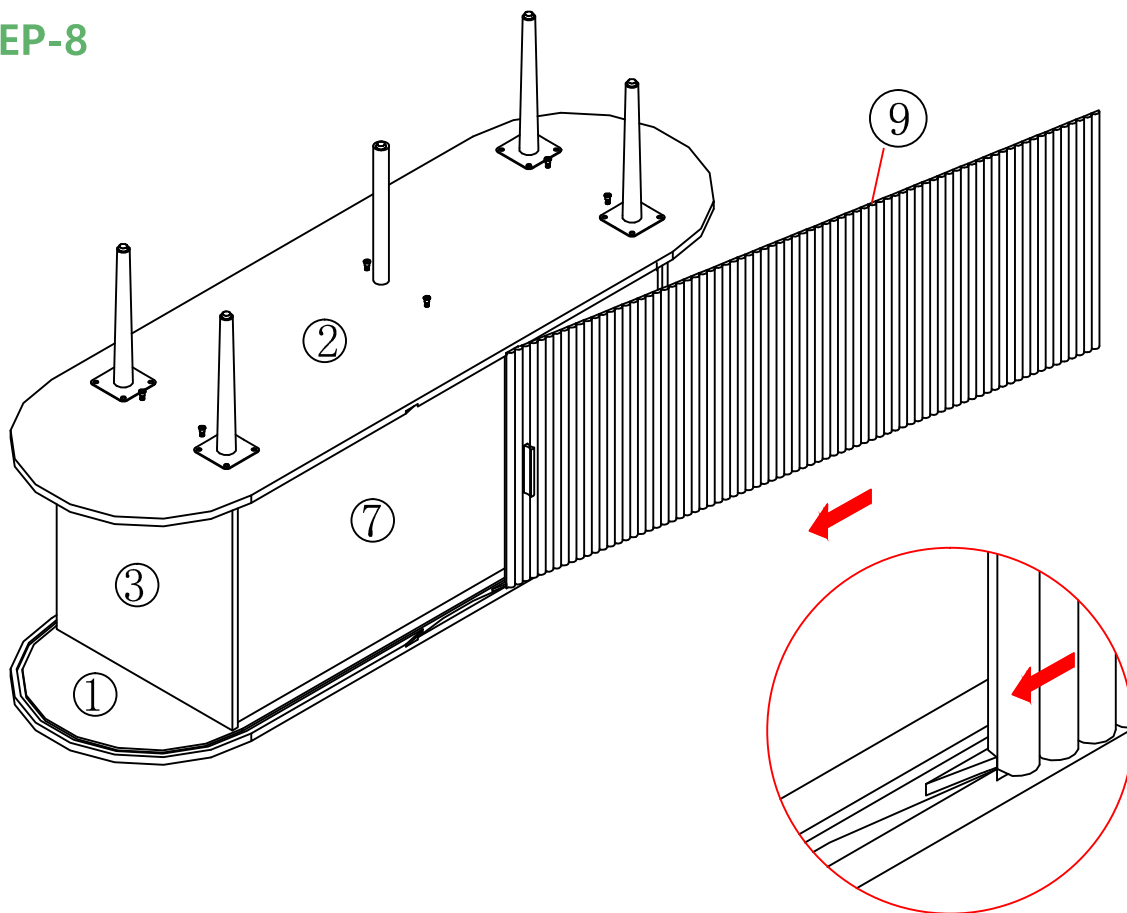

STEPS

STEP-9

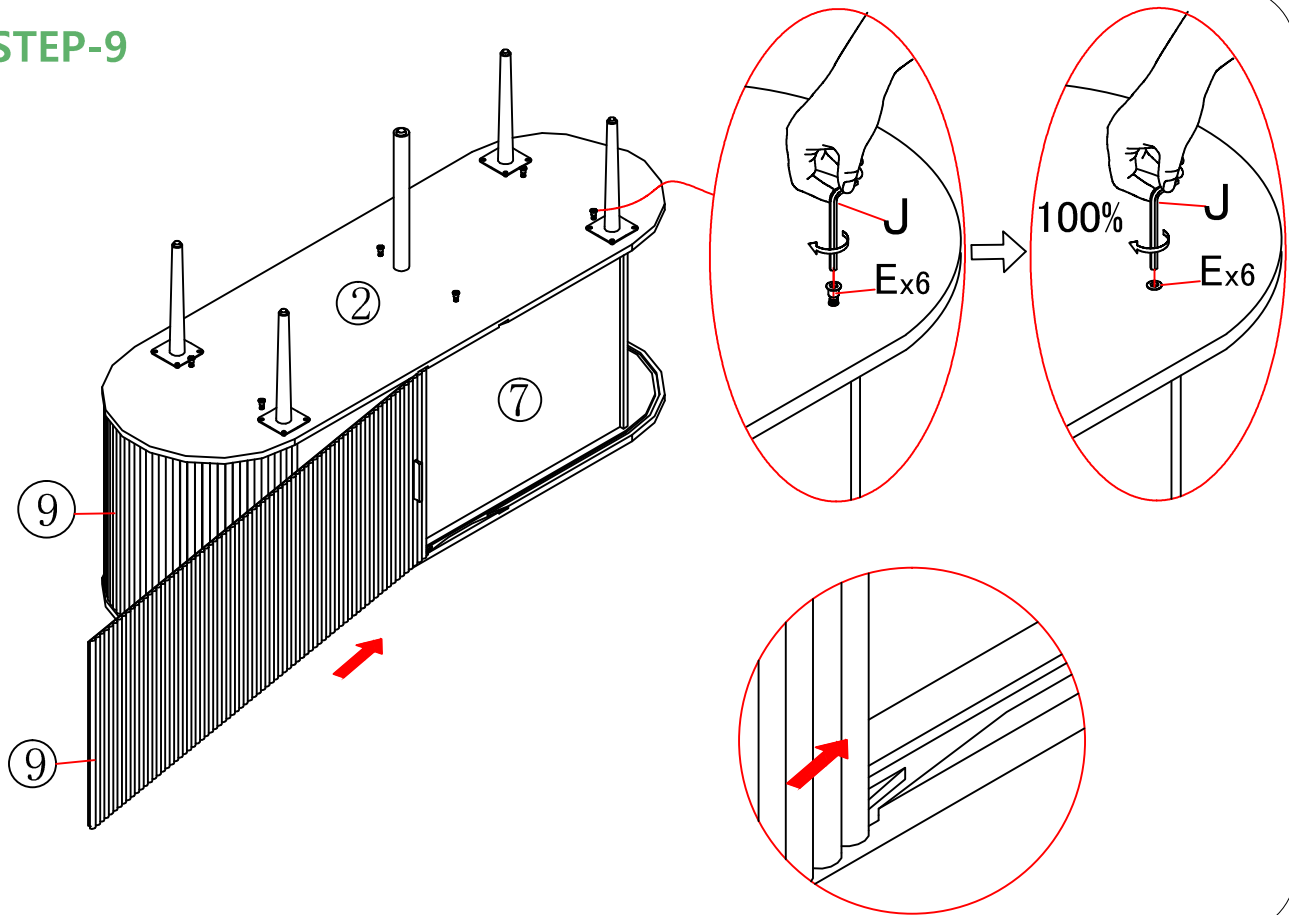

STEP-10 G x8PCS

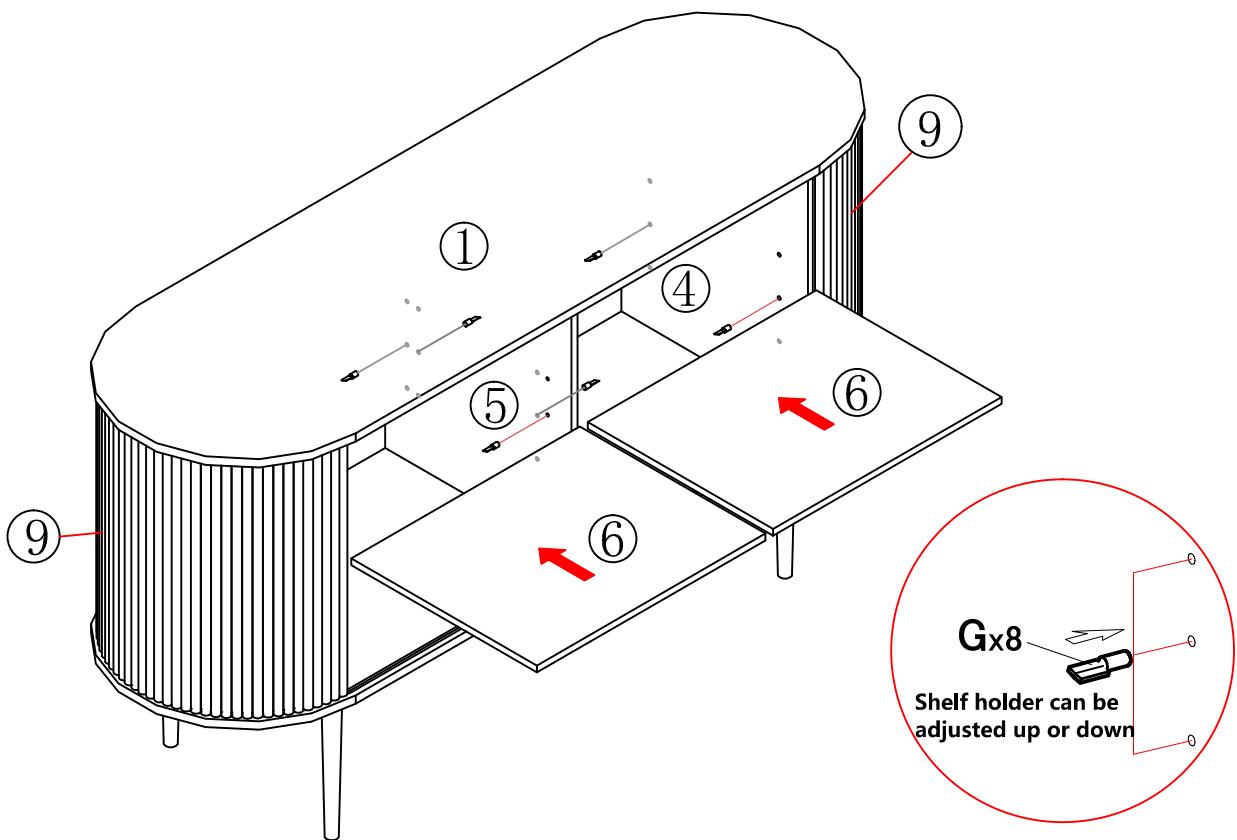



STEPS



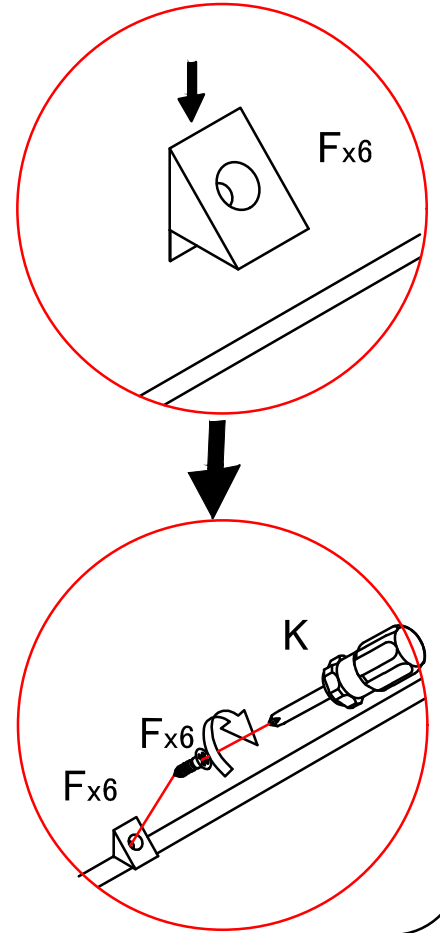
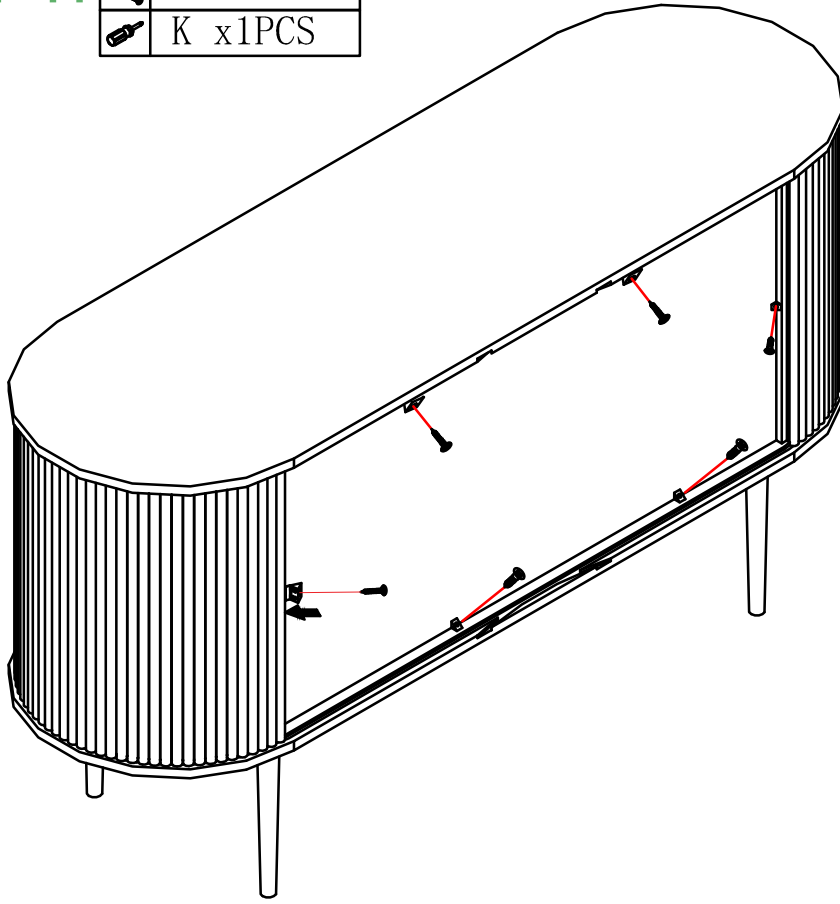

STEP-11

	F x6PCS
	K x1PCS



STEP-12



	L x2PCS
	K x1PCS
	G x1PCS

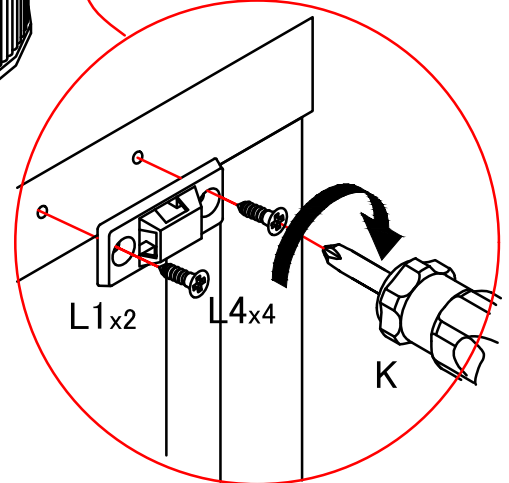
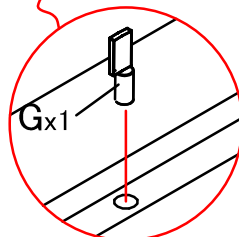
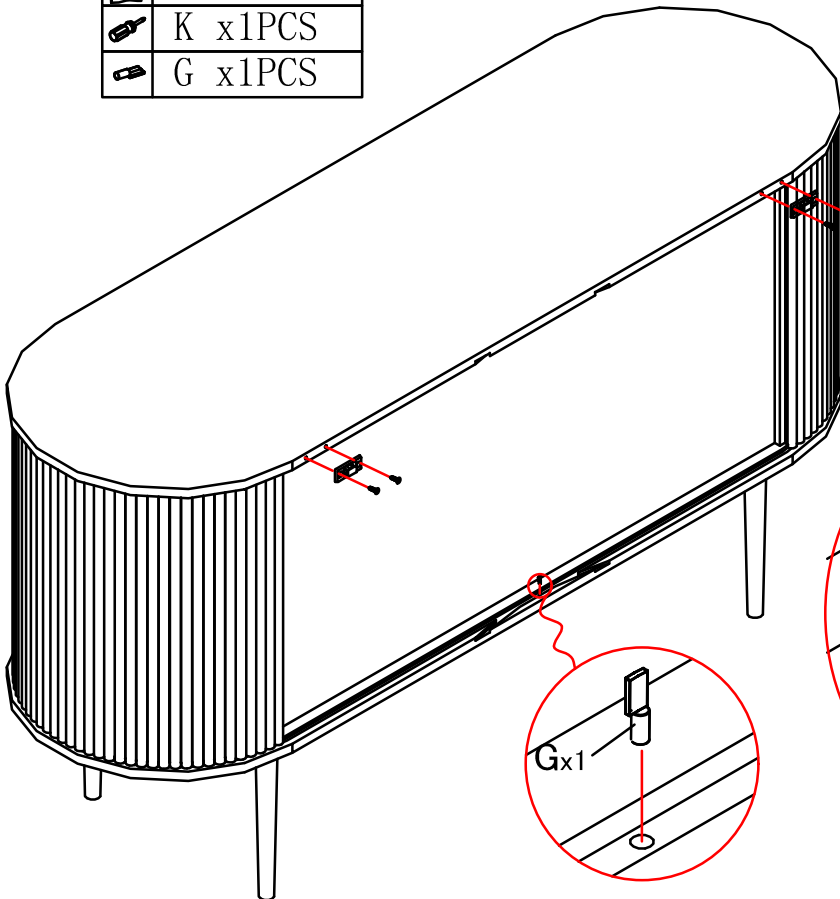



				
L1x2	L2x4	L3x4	L4x4	L5x2



STEPS

STEP-13



	L x2PCS
	K x1PCS

				
L1x2	L2x4	L3x4	L4x4	L5x2

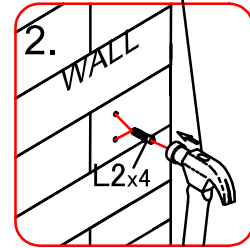
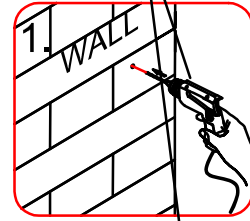
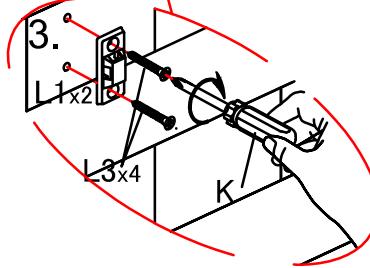
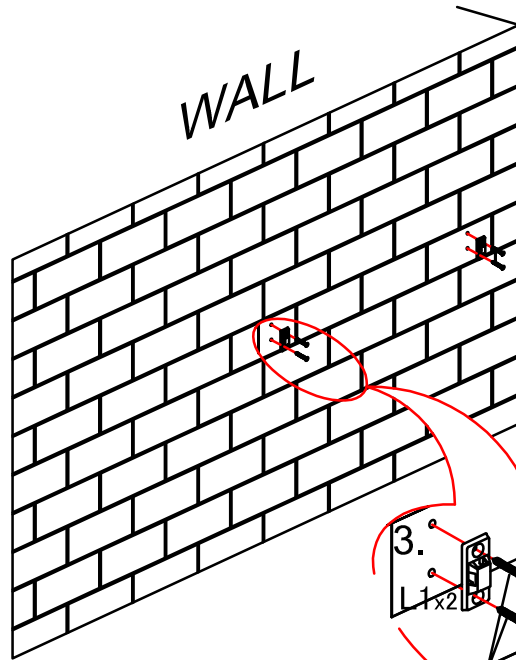
NOT PROVIDED



STEP-14

	L x2PCS
	K x1PCS

WALL

