

60" TV Stand

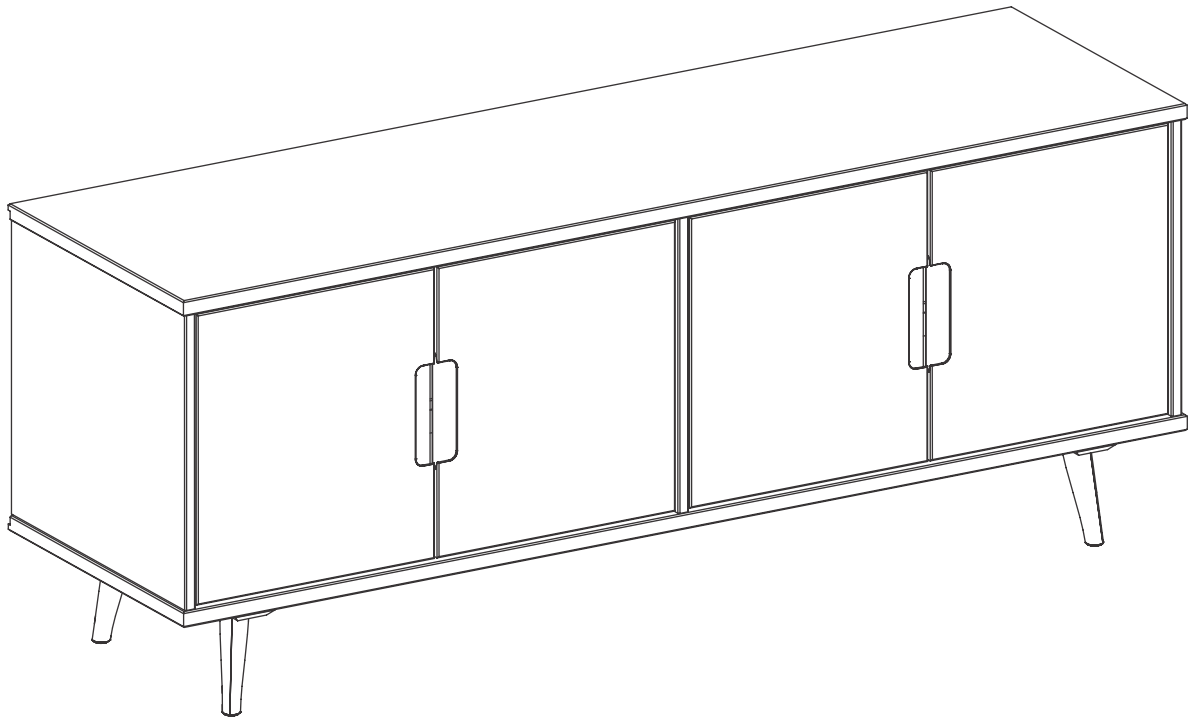

Time to get started

Set up a clean and soft workplace to avoid damage during assembly. You can use the box and internal protections as a cover. It also helps to double-check if you have got all the pieces and parts before diving into the assembly.

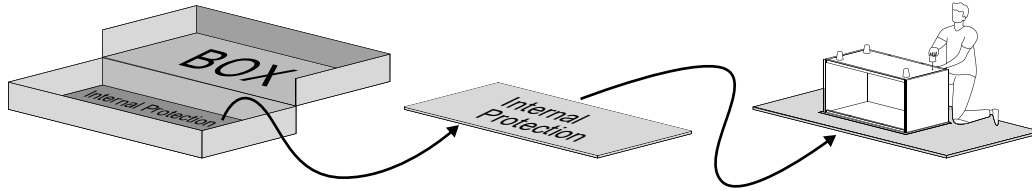

**Estimated time
for assembly**



2 People Build

**People recommended
for assembly**

Make it a team effort!
Grab a friend for
quicker, easier
assembly.

Tools Needed

Grab a Phillips head screwdriver and a hammer to conquer this assembly.

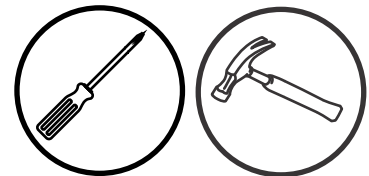

Use power tools with caution

This furniture is made of Solid Wood and Composite Wood, soft materials. If you choose to use power tools, set it to the slower setting. Be careful! Power tools can cause cracking or damage to the furniture, they can also damage the hardware if misused. Power tool damages are not covered by the warranty

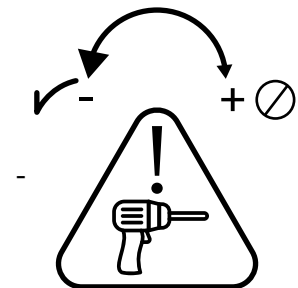

Slide care

Your furniture has highly durable wooden sliders. From time to time we recommend applying paraffin or standard candle wax to improve gliding of the sliders.

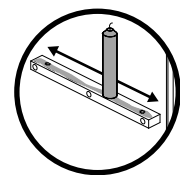





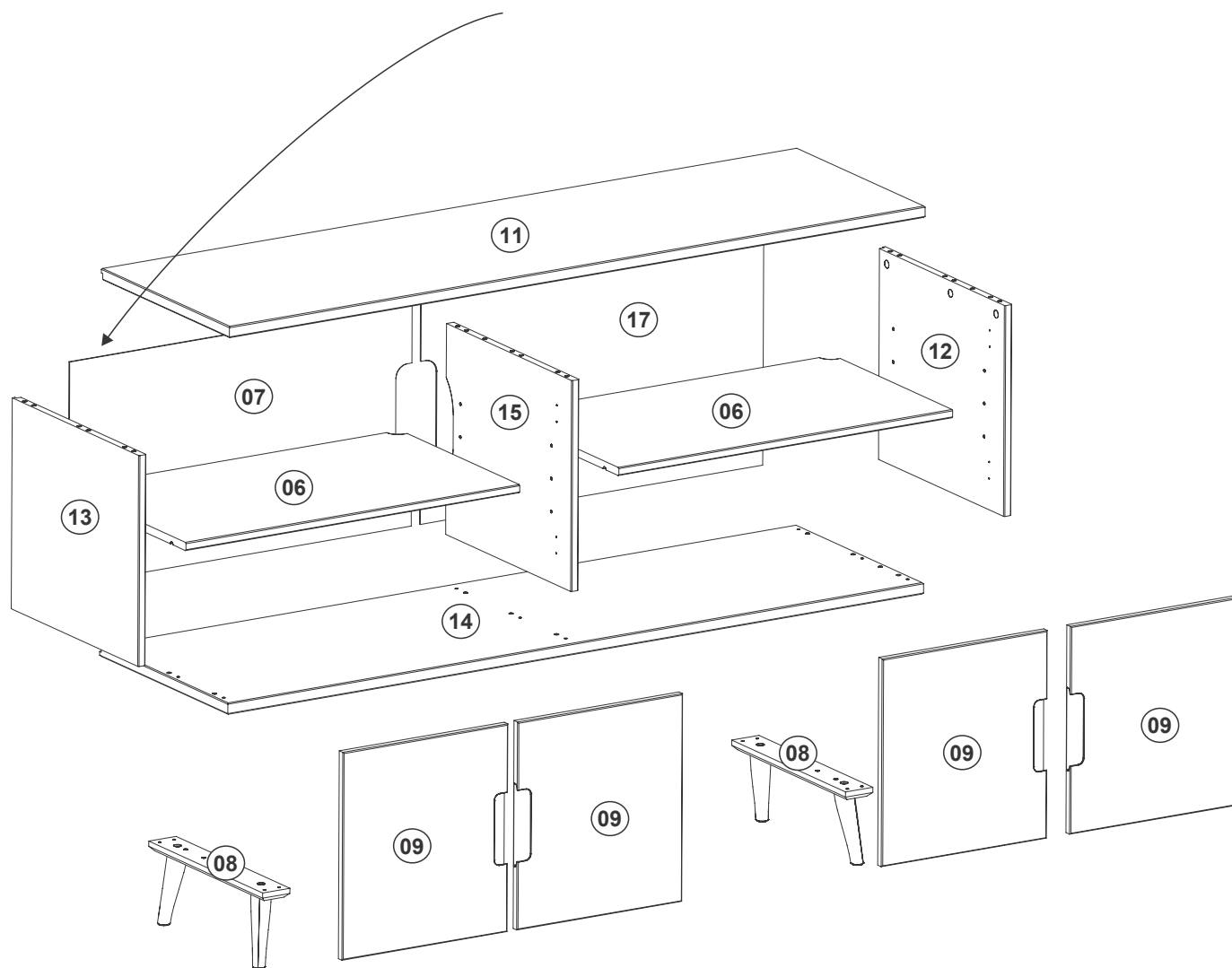



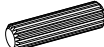





Part List

Part Number	Description	Quantity	Part Number	Description	Quantity
06	Shelf	02	12	Right Side Panel	01
07	Left Back Panel	01	13	Left Side Panel	01
08	Foot	02	14	Bottom Panel	01
09	Doors	04	15	Center Panel	01
11	Top Panel	01	17	Right Back Panel	02



Hardware List

Part	Size	Name	Quantity
A	 8x30mm	Wooden dowel	25
B	 3.5x14mm	Screw	36
C	 3.5x30mm	Screw	12
D	 4x40mm	Screw	10
E	 6.0x8mm	Shelf Support	08
F	 5x24mm	Cam bolt	09
G	 15x12mm	Cam Lock	09
H		Backstop	04
I	 20x8mm	Tack Nail	02
J	 8x8mm	Nail	30
K	 4x16mm	Screw	01
L	 6x35mm	Plastic Bush	01
M		Washer	02
N		Wall Anchor	01
O		Hinge	08

The hardware quantities listed above are required for proper assembly.
Extra hardware pieces may be included.

Step 1

Let's start! Insert Wooden dowel (A) into the Foot (08), Right Side Panel (12), Left Side Panel (13) and Center Panel (15).

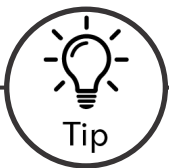
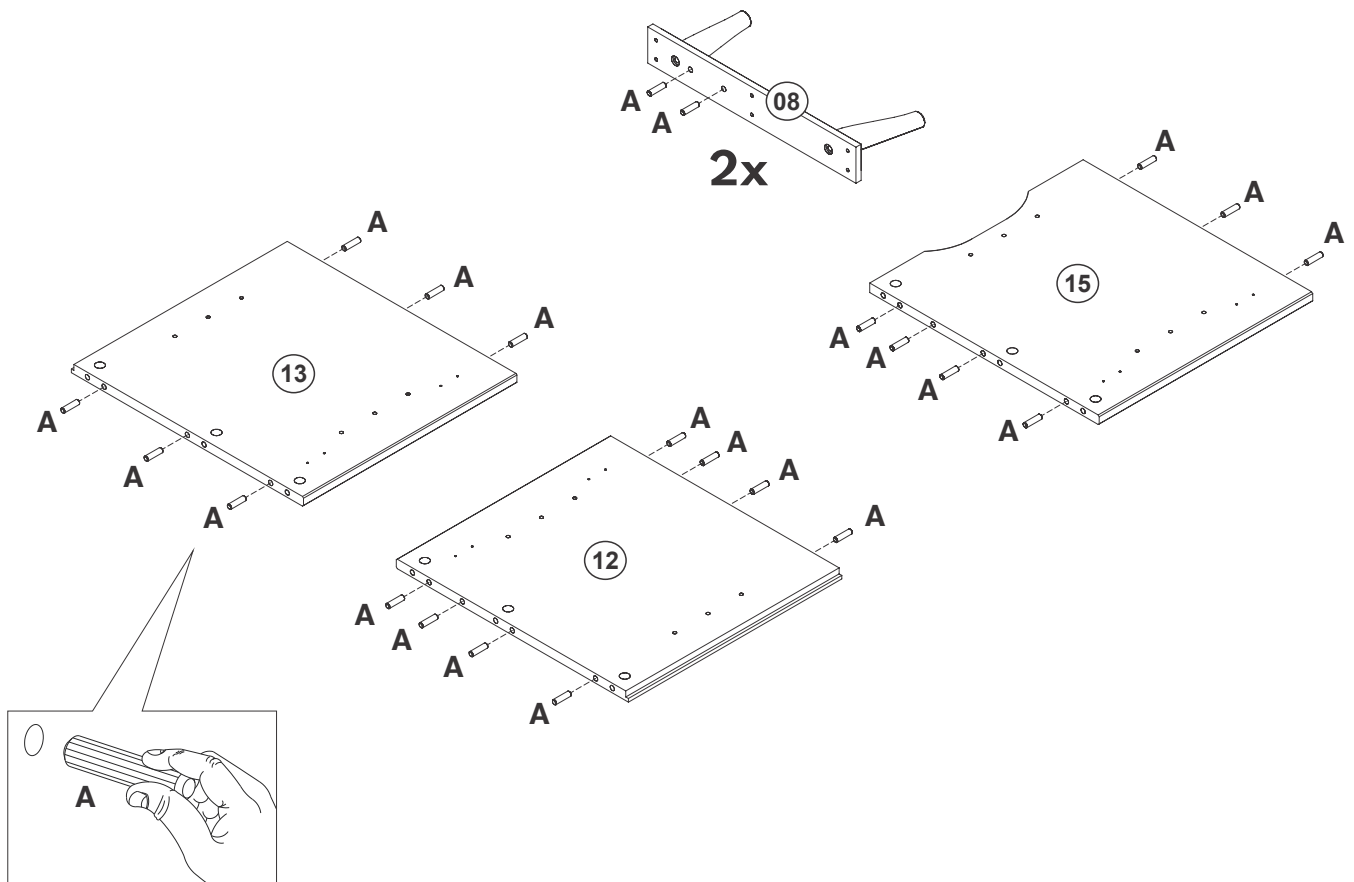
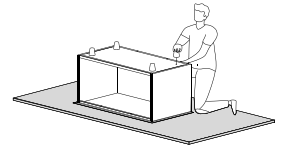

Wood Dowels

Dowels are essential in furniture assembly to create strong, precise connections.

They ensure structural integrity, prevent shifting, and simplify alignment, resulting in sturdier, longer-lasting furniture.

Follow these steps:

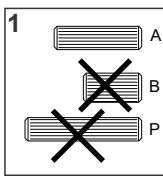

1: Select the appropriate size dowel according with step.

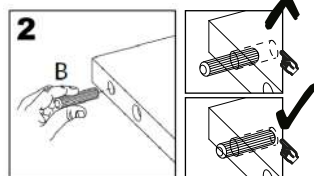

2: Insert into drilled hole and press firmly to ensure placement is set.

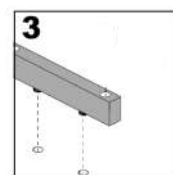

3: Align the dowel with corresponding piece and press together until secure.

Step 2

Insert Shelf Support (E) into Right Side Panel (12), Left Side Panel (13) and Center Panel (15).

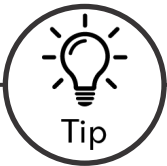
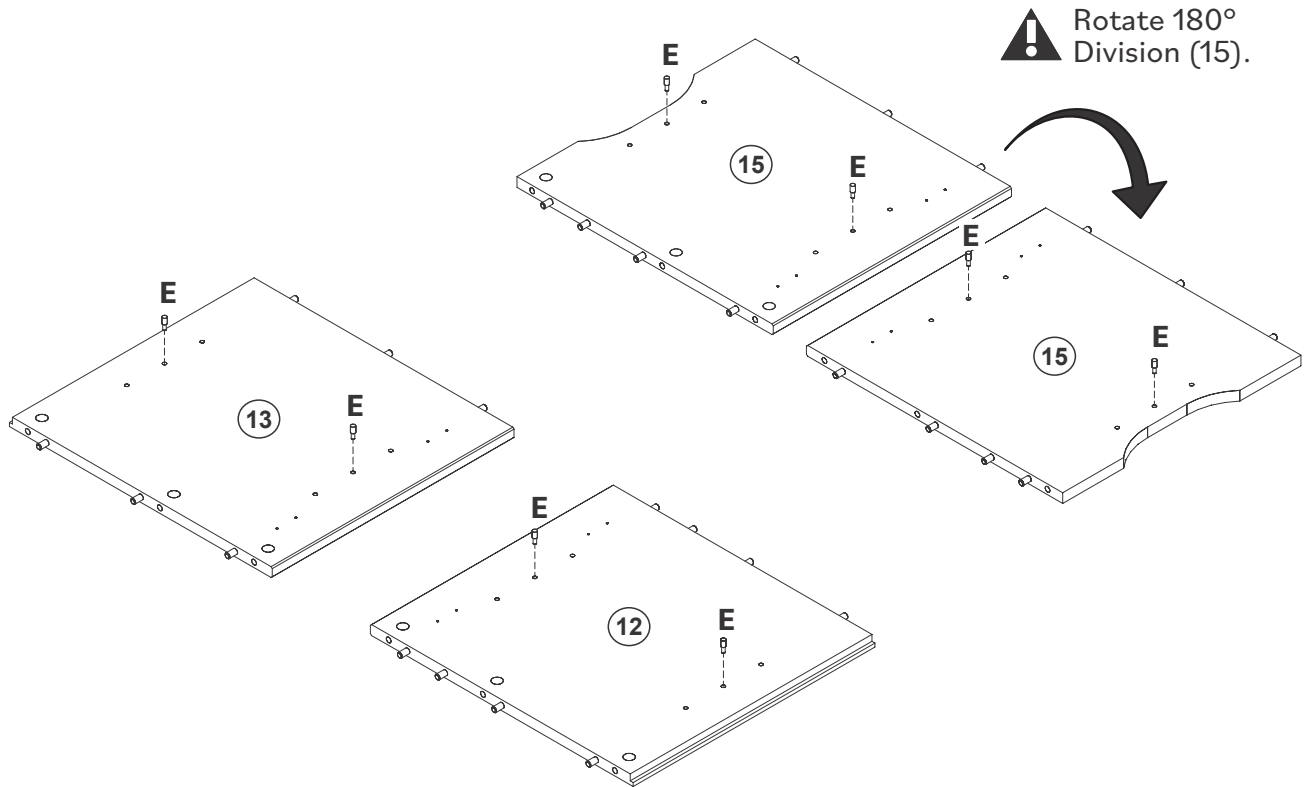

To keep your product looking its best and scratch-free, try assembling it on a soft surface like carpet or a blanket. This helps prevent any accidental scratches and keeps your furniture in top shape!

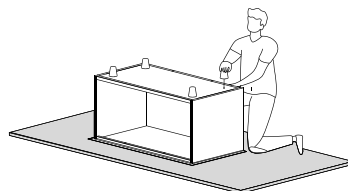

Step 3

Attach Cam Bolt (F) into Top Panel (11) with a Phillips head screwdriver.

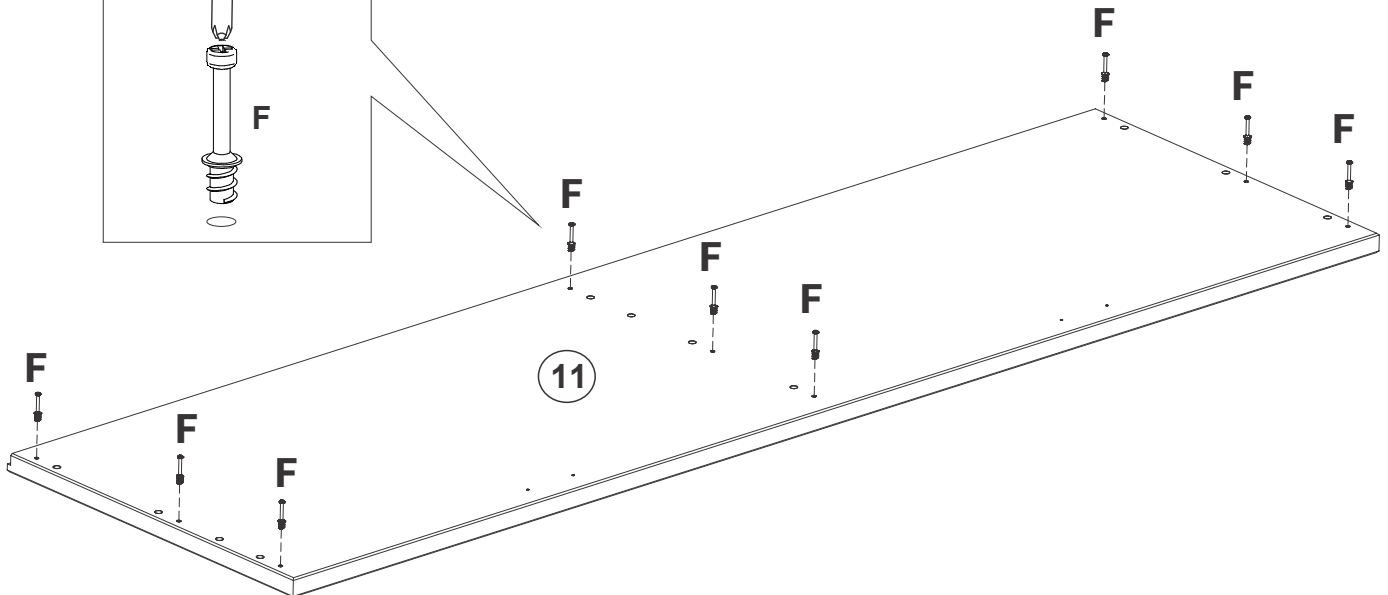
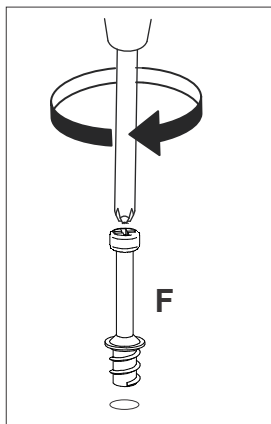
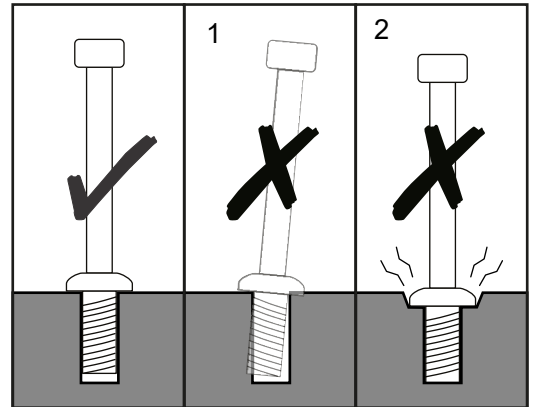
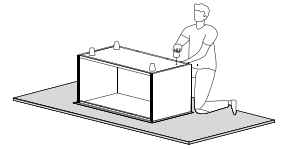

Step 4

Attach Backstop (H) into the Top Panel (11) with Screw (B) and a Phillips head screwdriver.

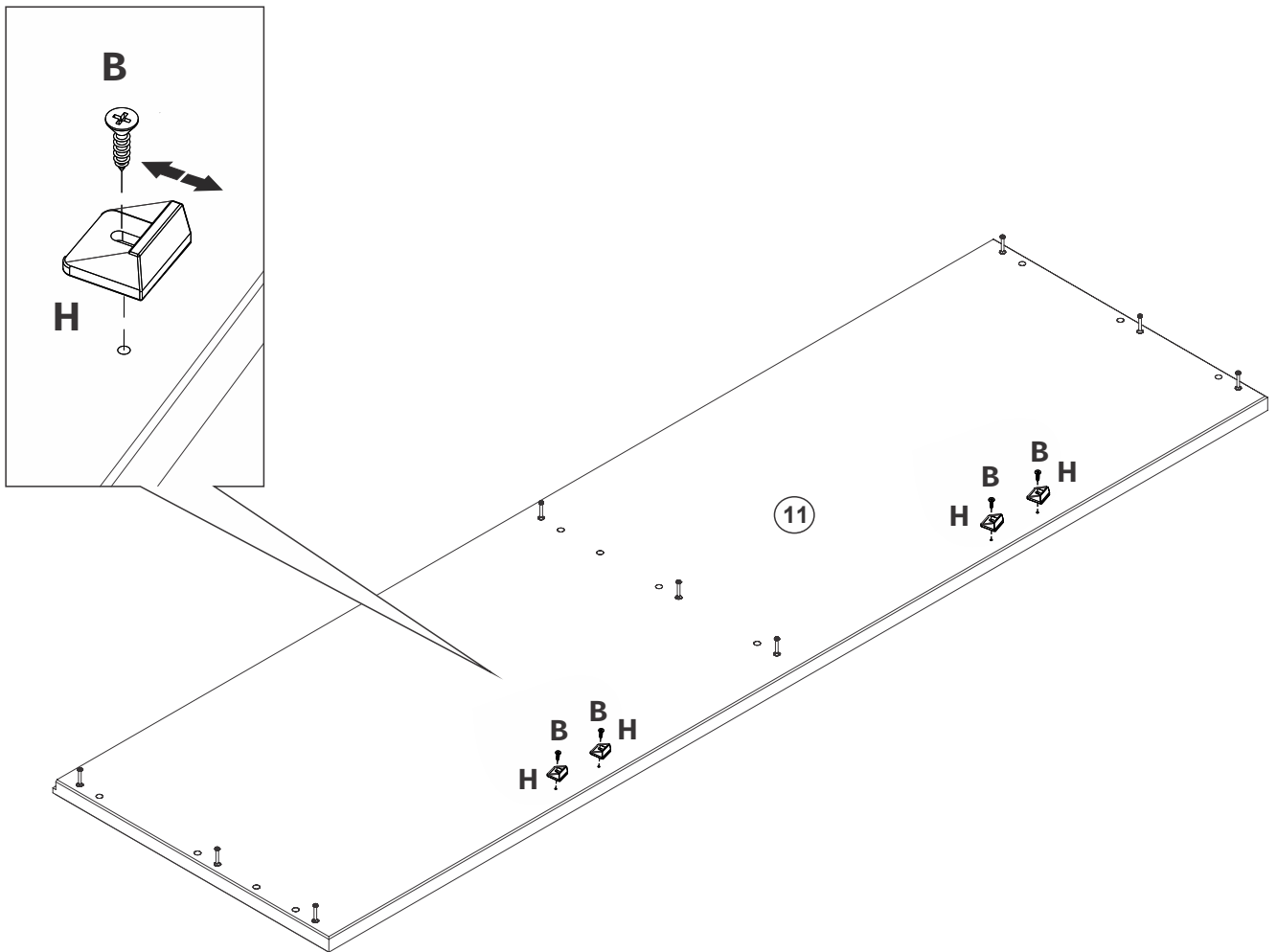
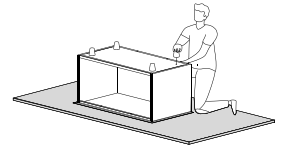

Step 5

Secure Feet (08) into the Bottom Panel (14). Insert Screw (C) in Feet (08) and attach with a Phillips head screwdriver.

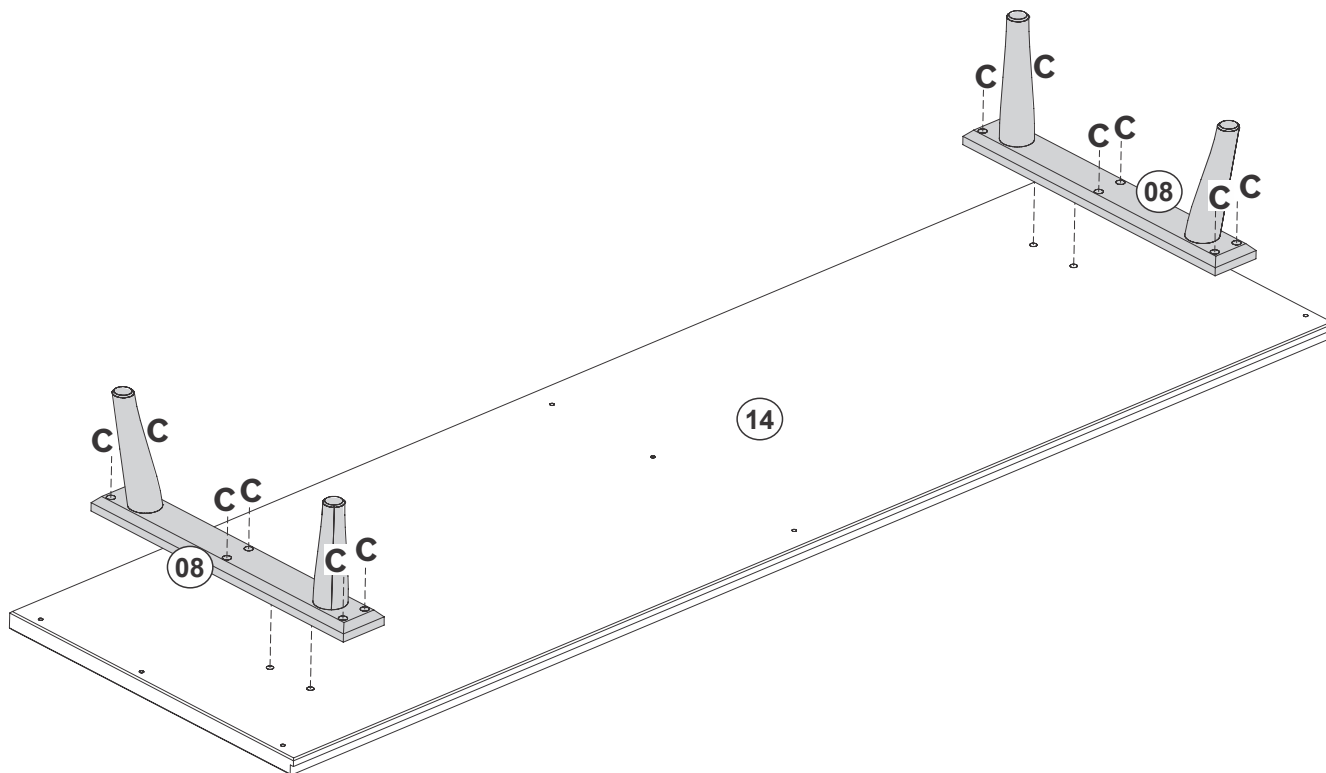
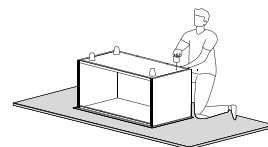

Once this step is completed, your product should look like this

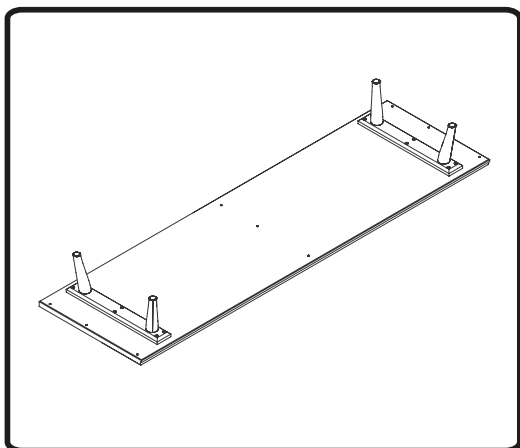

Step 6

Attach Right Side Panel (12), Left Side Panel (13) and Center Panel (15) to Bottom Panel (14) with screw (D) and a Phillips head screwdriver.

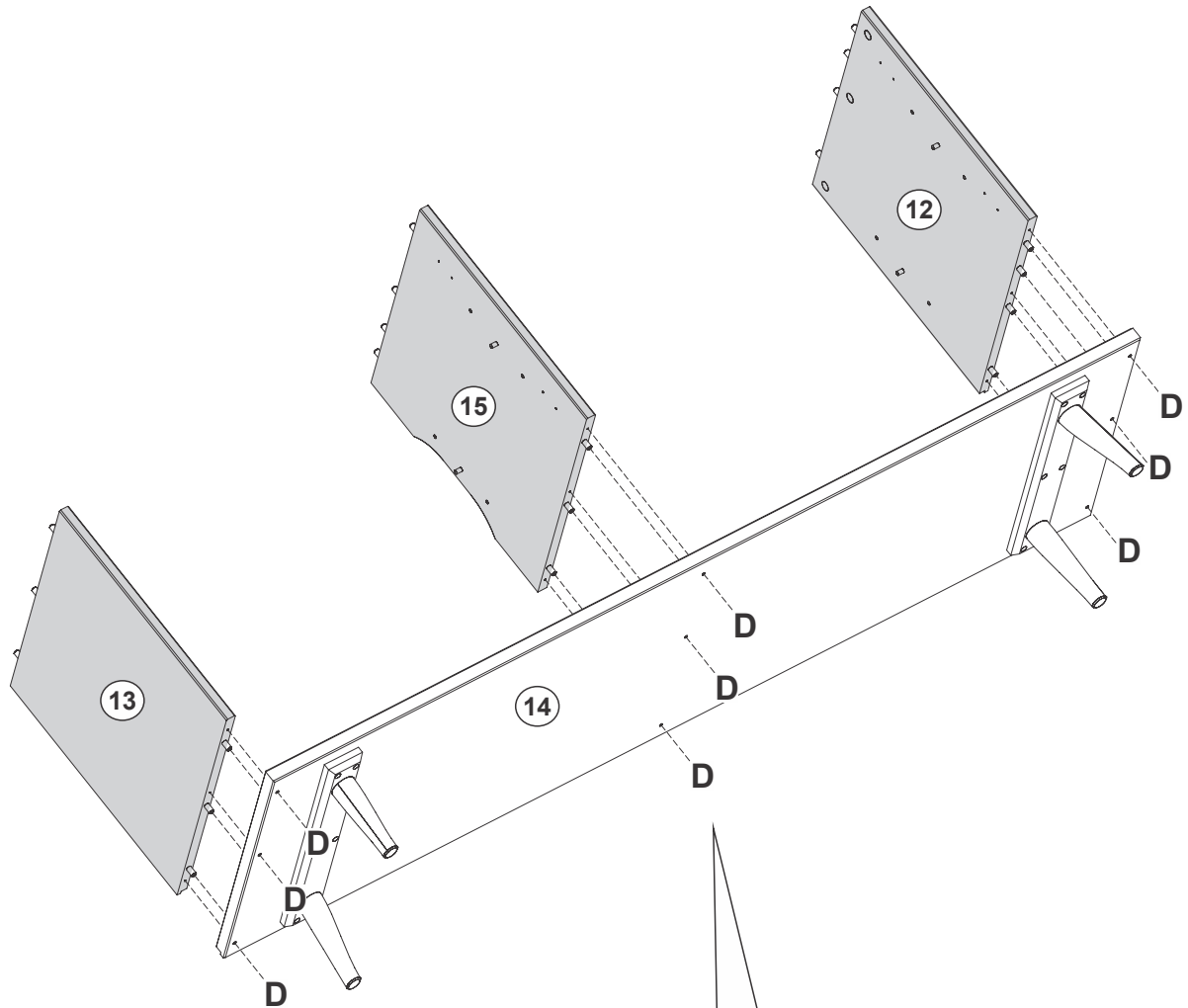
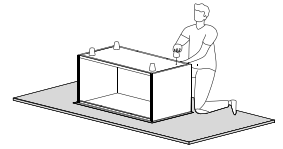

Once this step is completed, your product should look like this

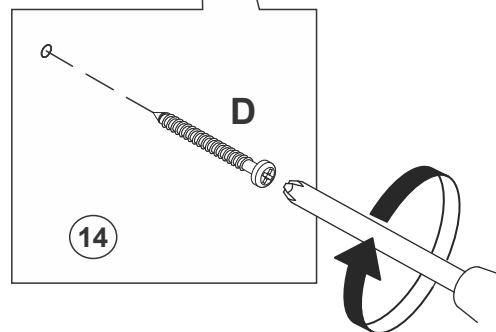
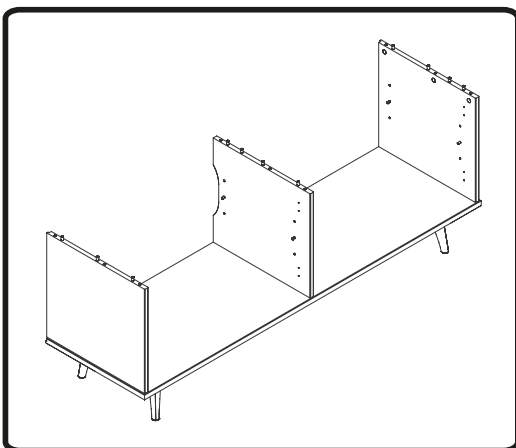

Step 7

Fit Top Panel (11) to Right Side Panel (12), Left Side Panel (13) and Center Panel (15). Insert Cam Lock (G) in Right Side Panel (12), Left Side Panel (13) and the Center Panel (15) and tighten using a Phillips head screwdriver.

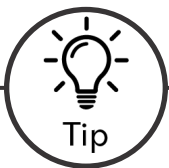
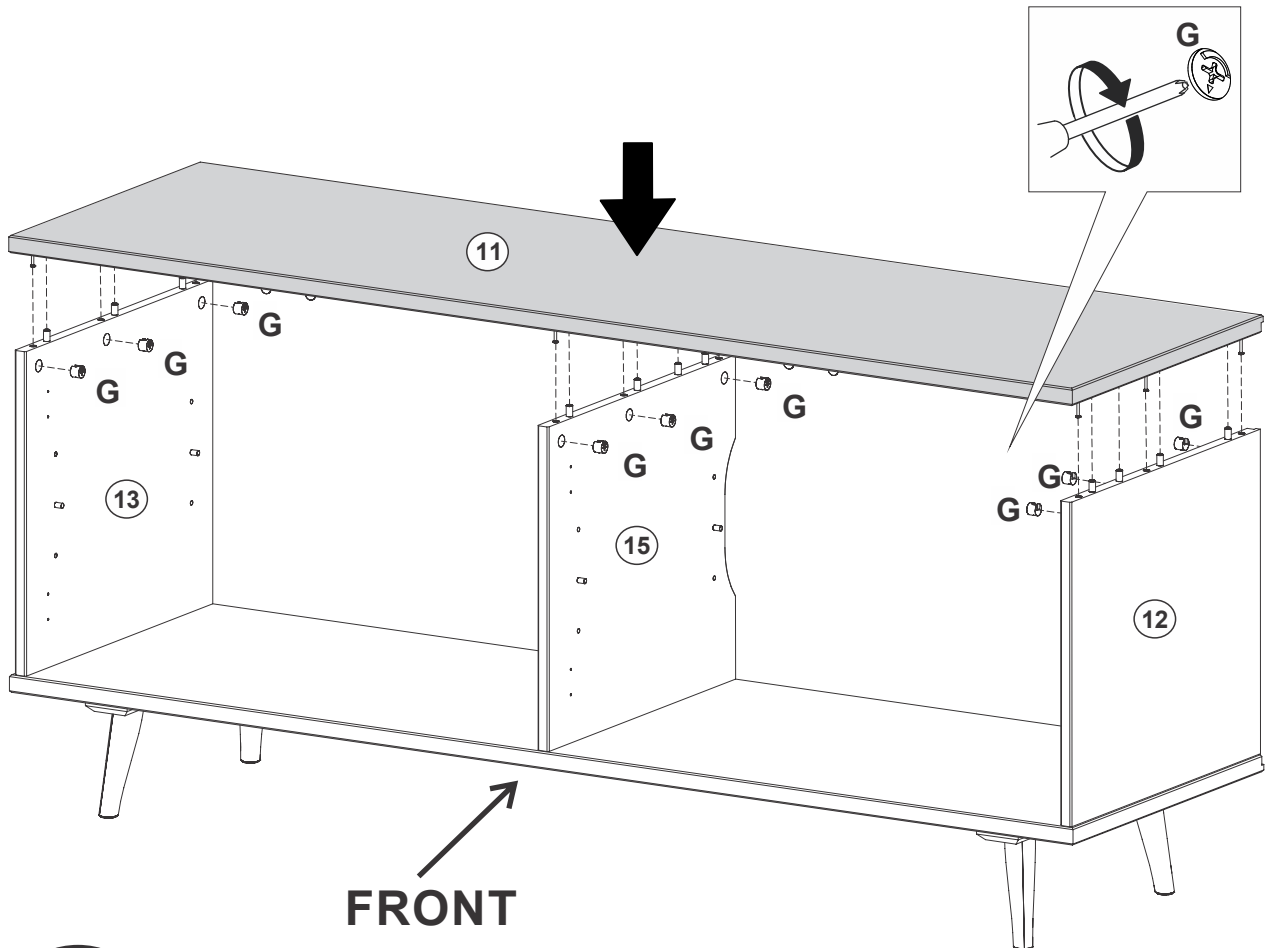
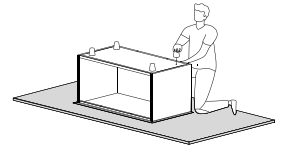

Tip

Cam Locks

Cam Locks help securely join two pieces together. Follow these easy steps.

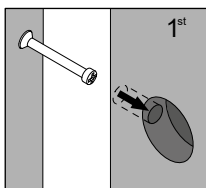

1: Insert Cam Bolt into bolt holes on the flat side. Don't over tighten!

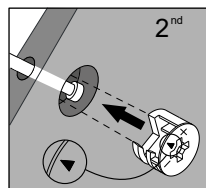

2: Assemble both parts together. The cam bolts goes in the drills holes that have a circular hole on the side, you should be able to see the cam bolt through it. After fitting parts together insert the cam lock on the side holes.

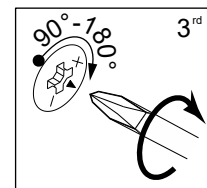

3: On the back of the Cam Lock will be a 'C' shape. Insert the Cam Lock so the opening of the 'C' fits over the Cam Bolt. Tighten with the screwdriver.

Step 8

Secure Left Back Panel (07) and Right Back Panel (17) to Top Panel (11), Right Side Panel (12), Left Side Panel (13) and Bottom Panel (14) with Nail (J) and a hammer. Secure Left Back Panel (07) and Right Back Panel (17) using Tack Nail (I) and a hammer.

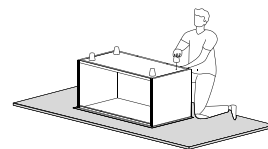

Warning, name and address of the supplier and date of the supplier and date of production.

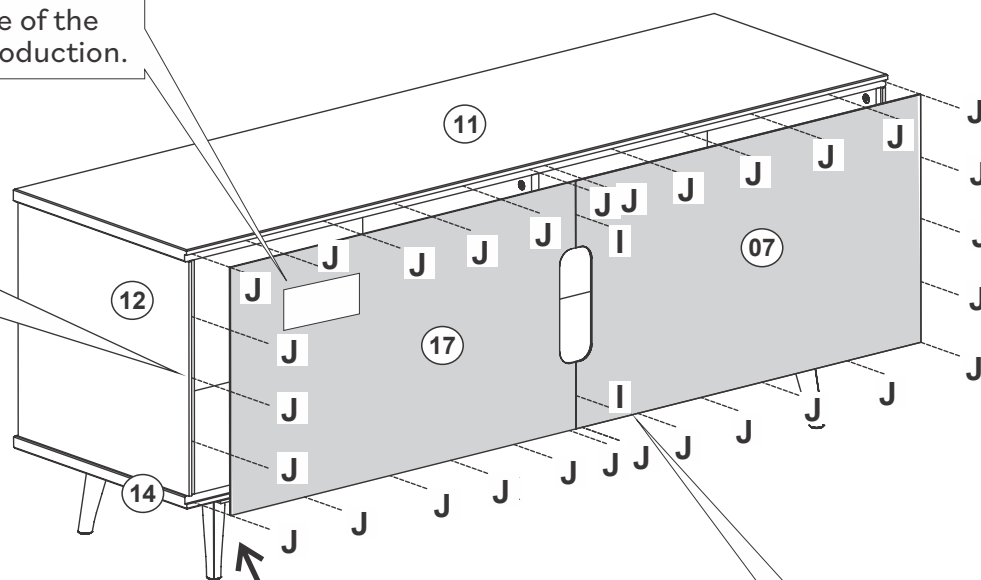
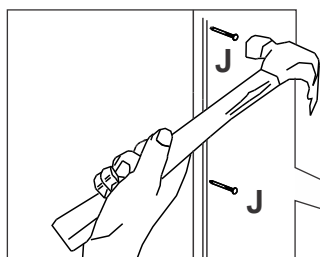

BACK

Once this step is completed, your product should look like this

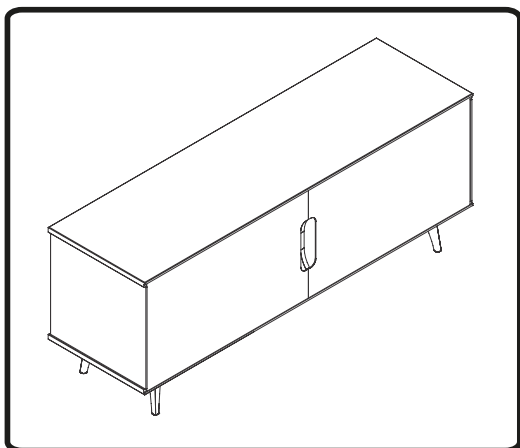
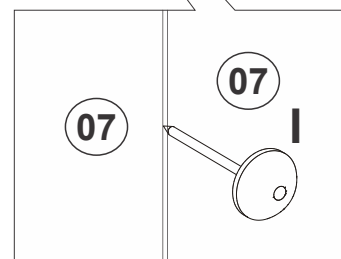

Step 9

Place Shelf (06) on the Shelf supports (E).

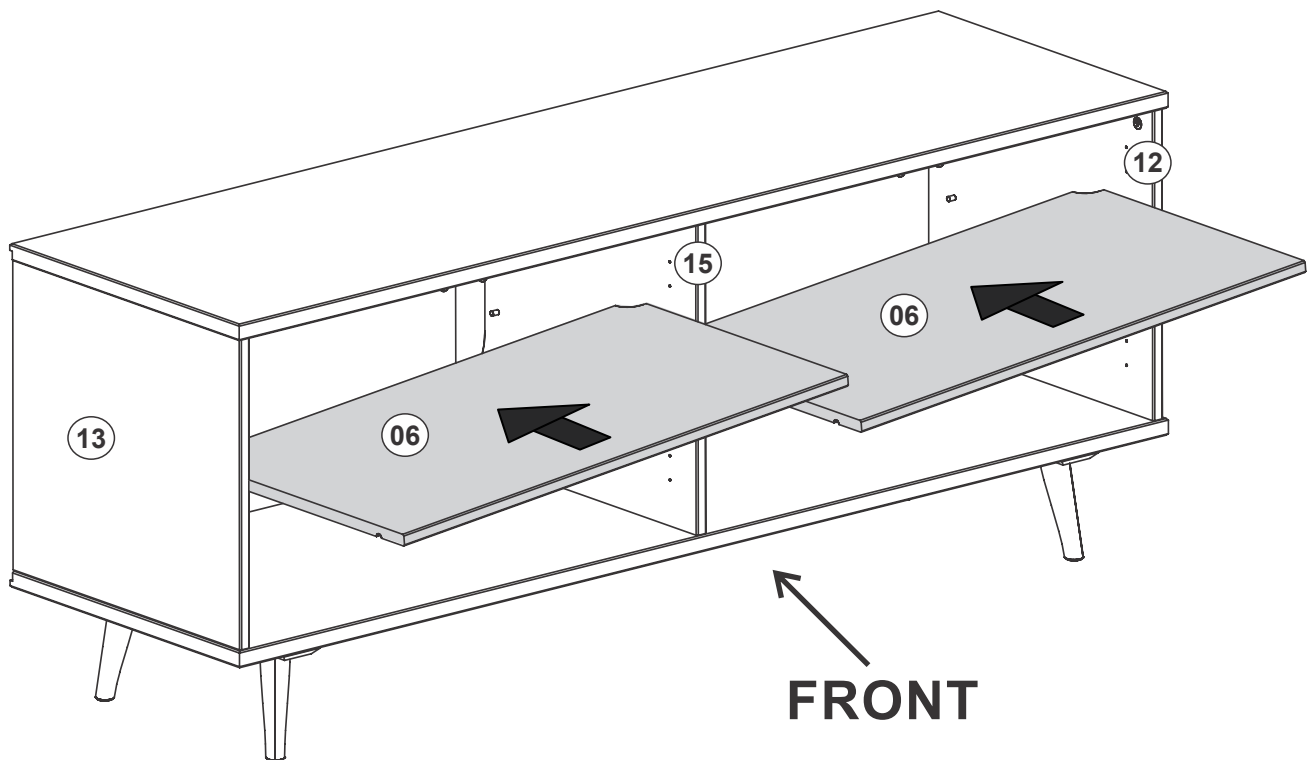
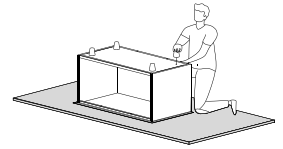

Once this step is completed, your product should look like this

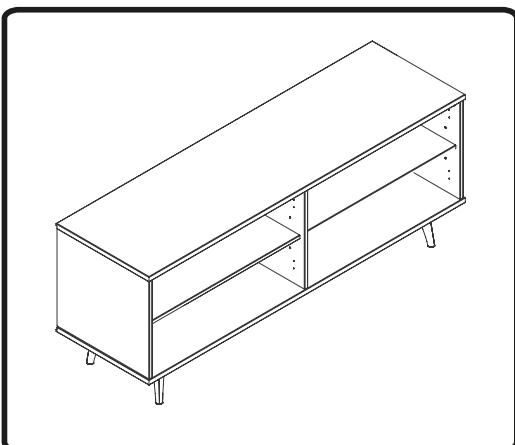

Step 10

Attach Hinge (O) into the holes in the Doors (09) with Screw (B) and a Phillips head screwdriver.

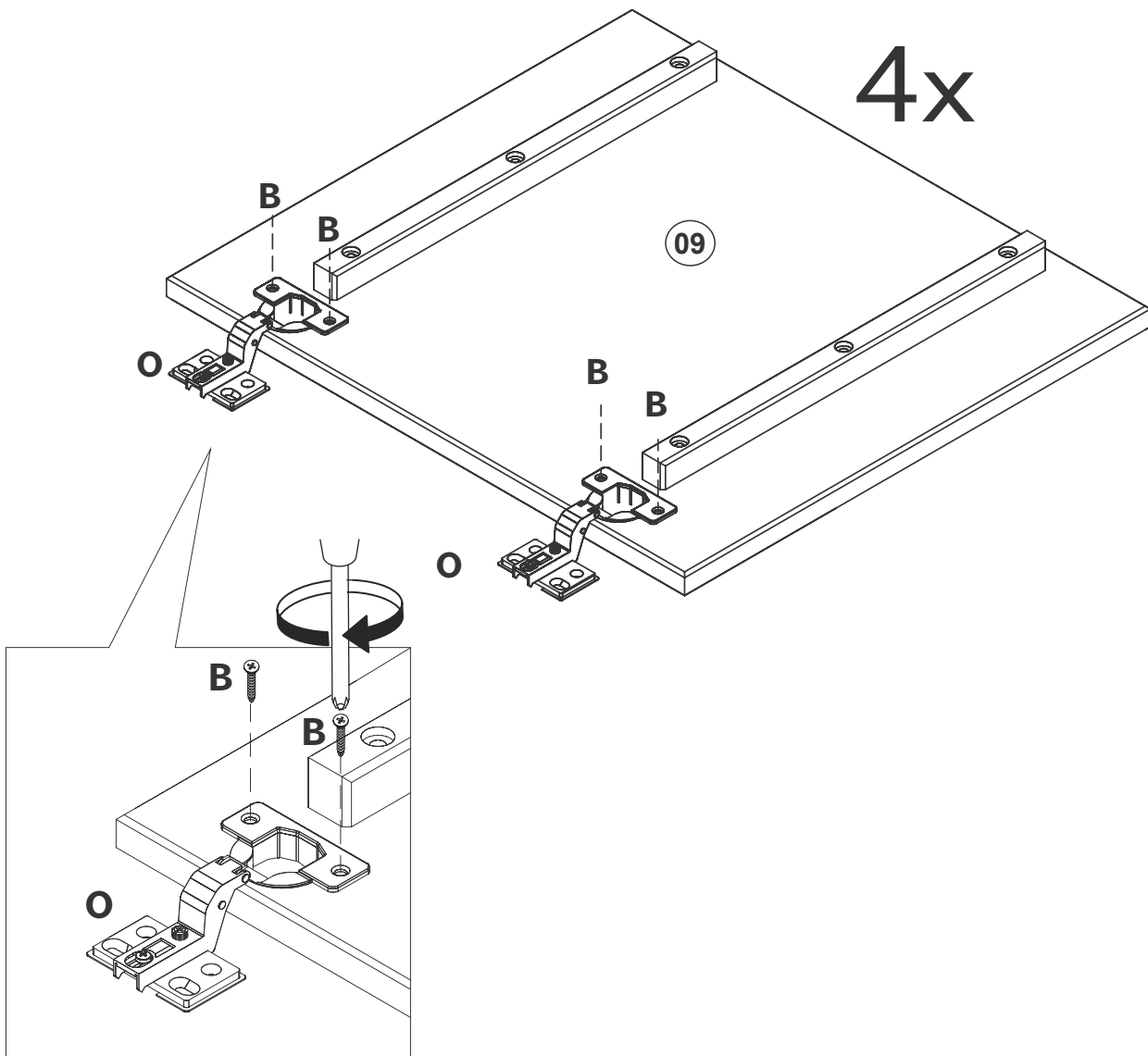
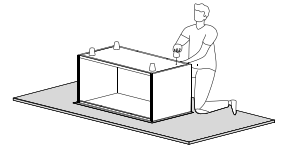

Step 11

Secure the Doors (09) to the Right Side Panel (12), Left Side Panel (13) and Center Panel (15) with Screw (B) and a Phillips head screwdriver.

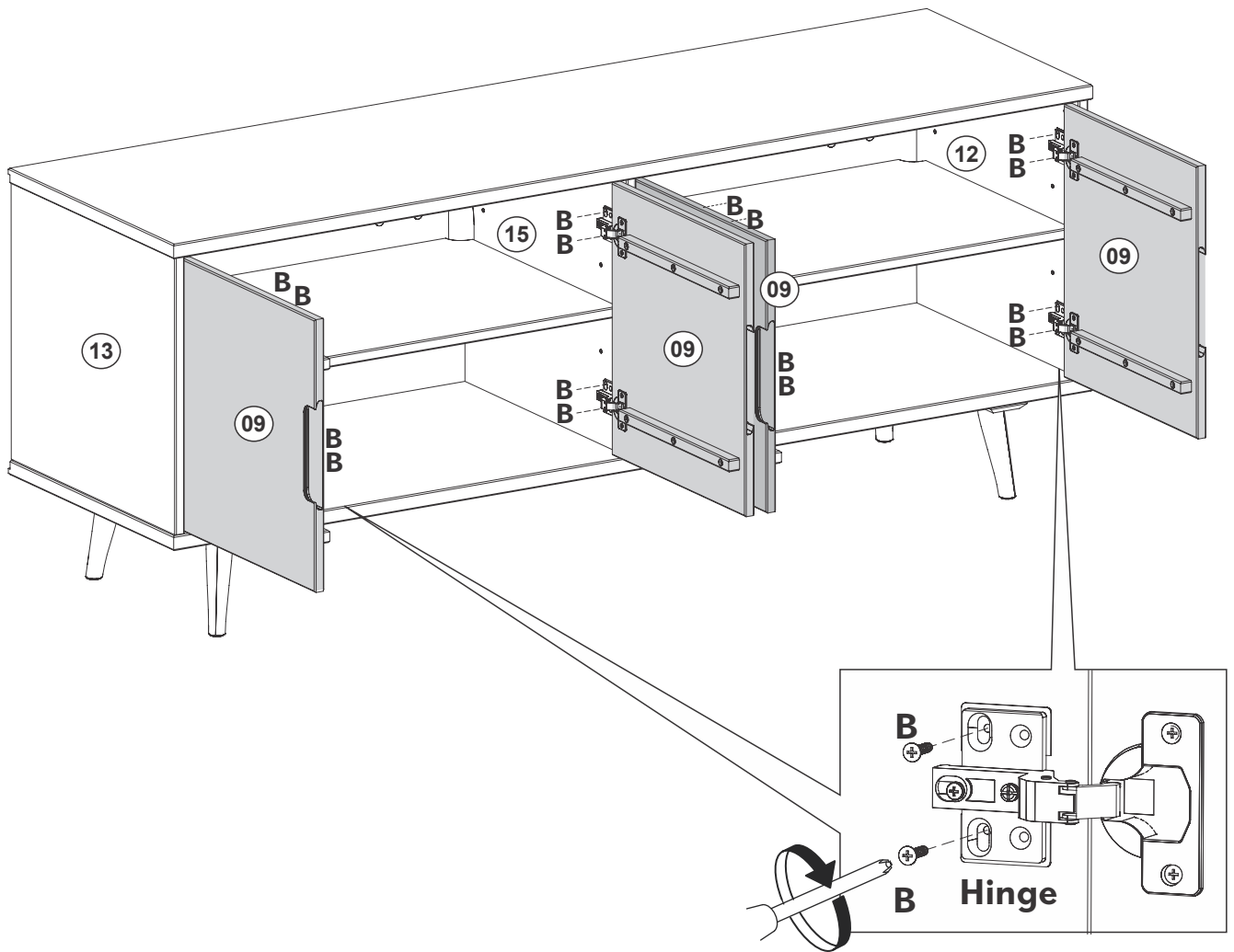
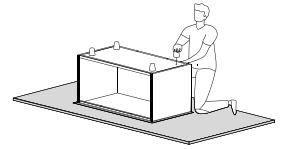

Step 12

To adjust the hinges you can follow this diagrams

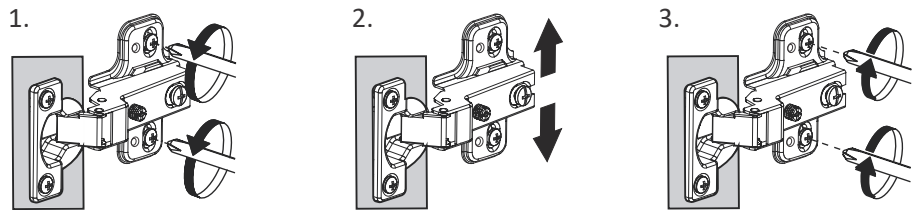
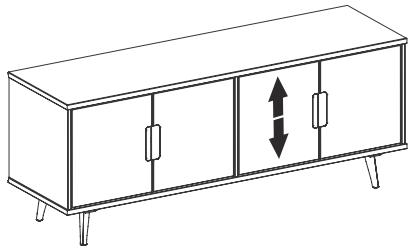
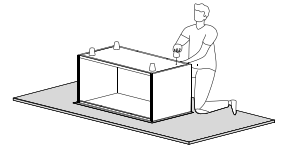

Door adjusts up and down by loosening top and bottom screws

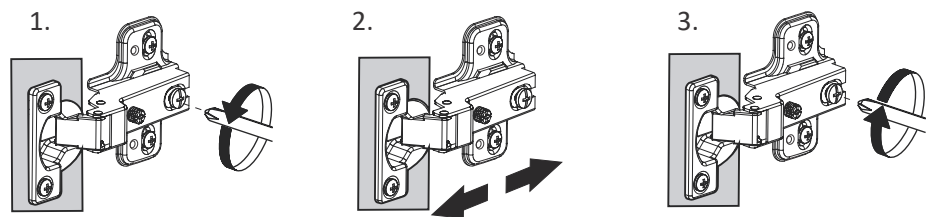
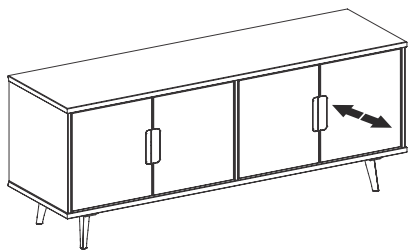

Loosen back screw to adjust door forward and back

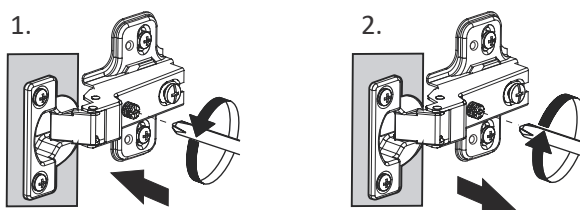
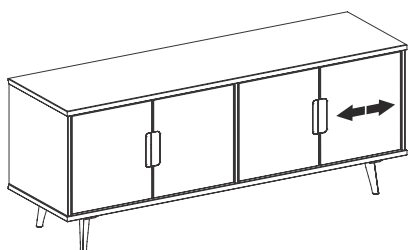

Adjust the door's distance from the side panel with the center screw

Check if you door is correctly adjusted or repeat this to have it perfectly placed

Step 13

To finish this up, let's secure your dresser to the wall!
Attach the Wall anchor (N) to your dresser using Washer (M) and a screw (K).

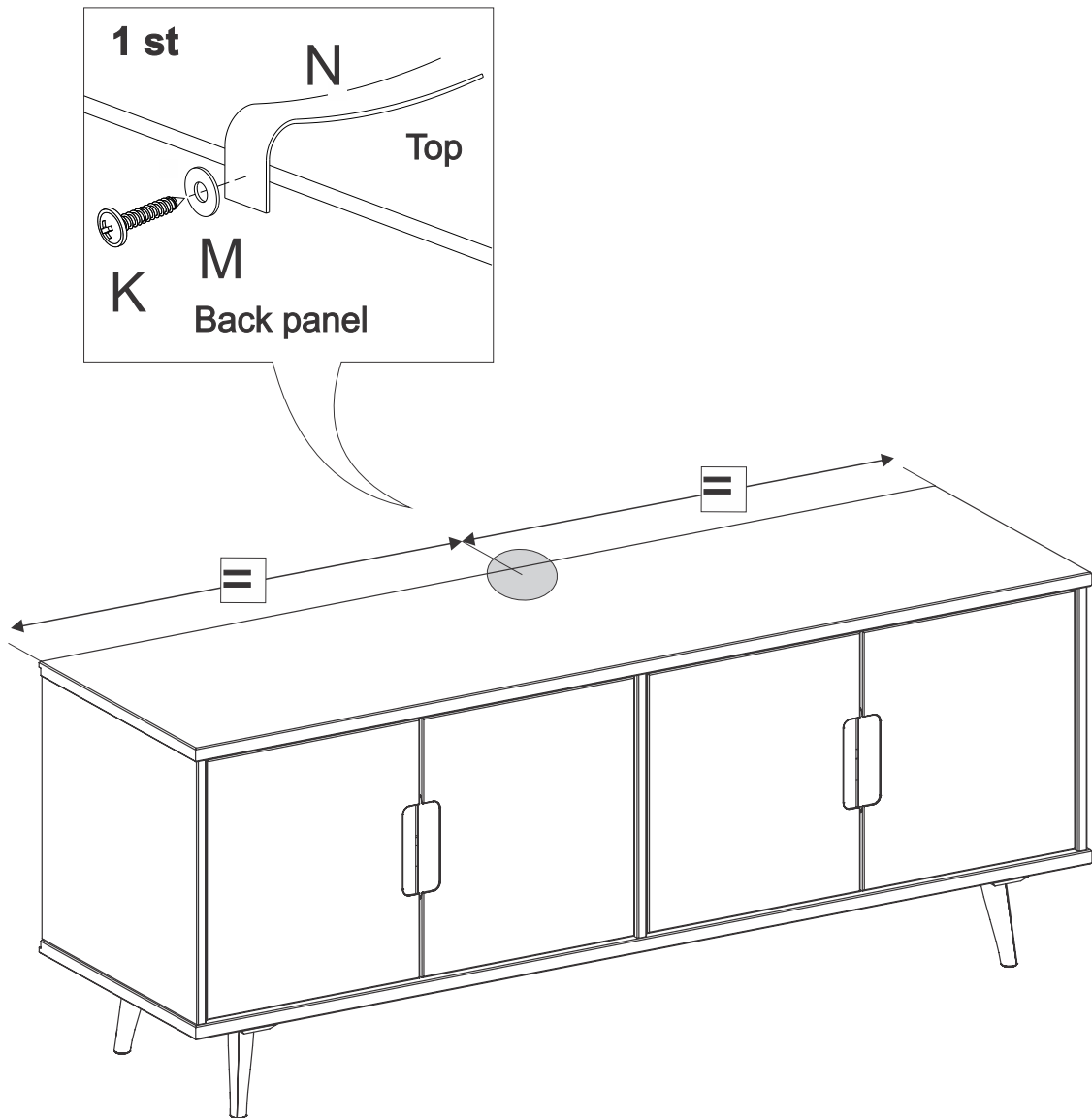

Step 14

Insert the Plastic bush (L) into the wall. Then, secure the Wall anchor (N) to the wall using a Washer (M) and a screw (D).

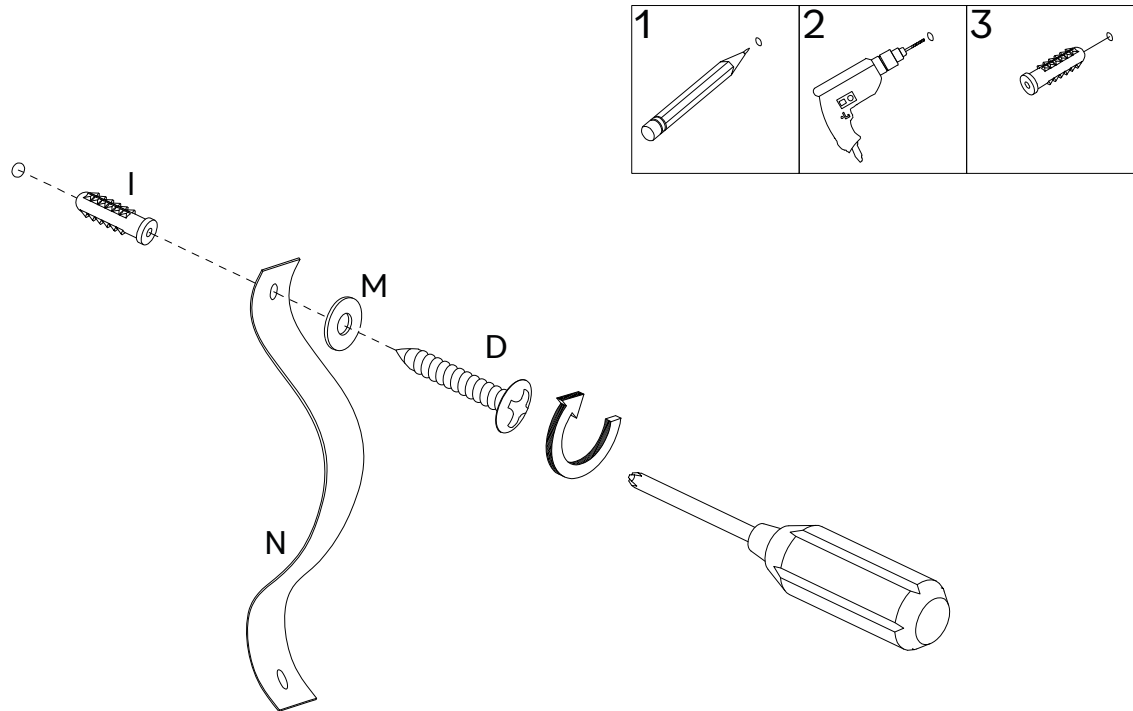

WARNING

Serious or fatal crushing injuries can occur from tip-over. To help prevent tip-over, install tip restraints per instructions. If using to support a television or monitor:

- Death or serious injury may occur when children climb on audio/or video equipment furniture. Remote control or toys placed on the furnishing may encourage a child to climb on the furnishing and as a result the furnishing.
- Do not place TV near front the edge of the product.

To further reduce the risk of serious injury and death from tip-overs:

- Place heaviest items in the lowest compartments or drawers.
- Never allow children to climb or hang on drawers, doors or shelves.
- Never open more than one drawer at a time.

The use of tip-over restraints may only reduce, but not eliminate the risk of tip-over.

For safe mounting, it is essential to use wall anchors appropriate to your wall type (i.e., plaster, drywall, concrete, etc). Mount to wood studs whenever possible. Note: if you are unsure about your wall type or what mounting the method you should use, consult a qualified professional or your local hardware store.

Name and address information for the manufacturer responsible for the anti-tip hardware and date of production can be found on the label on the back of the furniture.

You did it! Enjoy your new TV Stand!

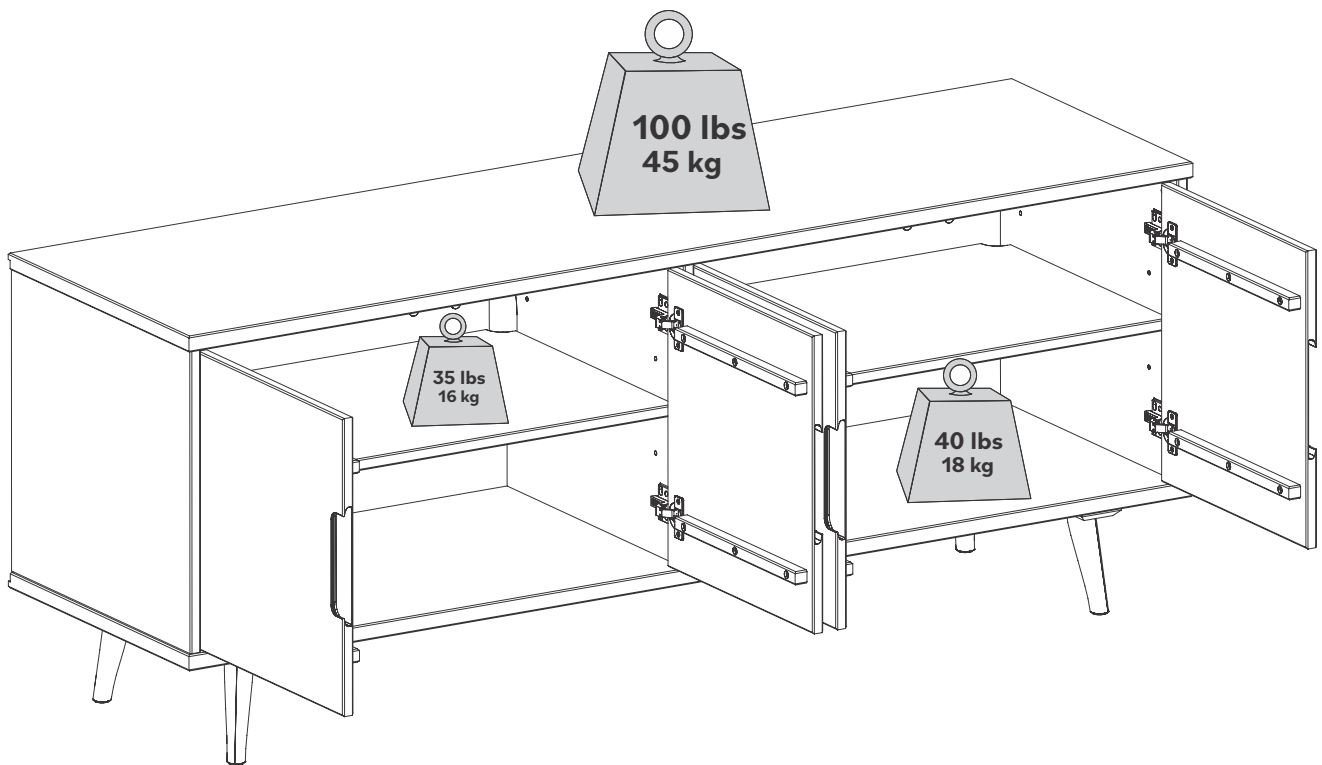

Assembling furniture can be tricky sometimes.

Our customer service team, is here for product information, help assembling a product, or for any other customer support issue

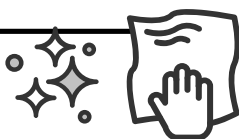

For cleaning, never use abrasives, use a soft cloth and water with neutral soap to clean the furniture.

60" TV Stand avec 4 Portes

60" TV Stand com 4 Puertas

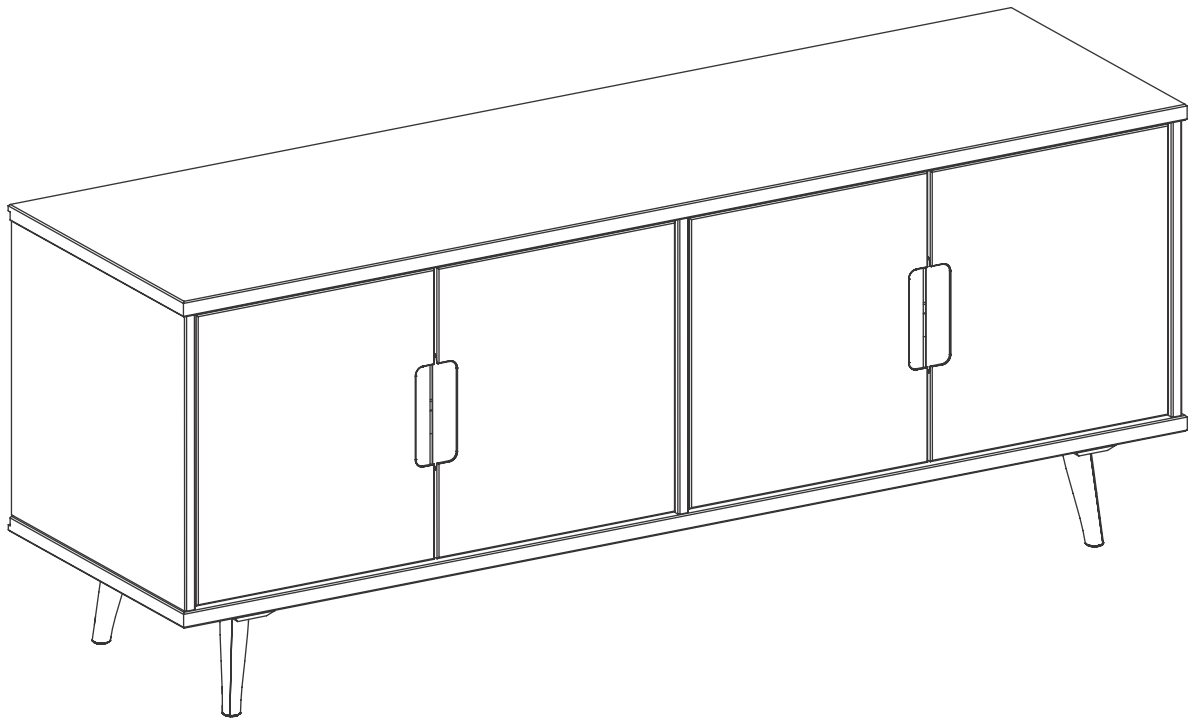

Il est temps de commencer / Hora de empezar

Prépare un lieu de travail propre et souple pour éviter tout dommage lors de l'assemblage. Tu peux utiliser la boîte et les protections internes comme base. Vérifie également que tu disposes de toutes les pièces et parties avant de te lancer dans l'assemblage.

Prepara un lugar de trabajo limpio y blando para evitar daños durante el montaje. Puede utilizar la caja y las protecciones internas como base. Comprueba también que tiene todas las piezas y partes antes de sumergirse en el montaje.

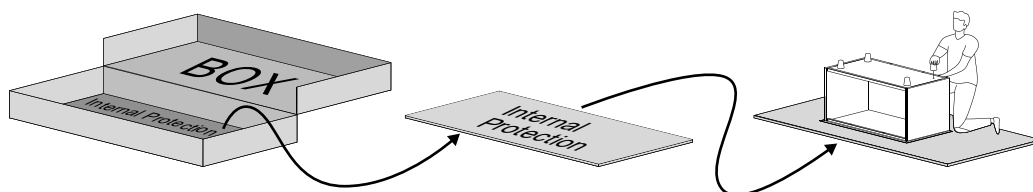

**Temps de montage
estimé**

**Tiempo estimado
de montaje**



2 Personnes
2 Personas

**Personnes recommandées
pour le montage**

Fais-en un effort d'équipe !
Appelle un ami pour un assemblage
plus rapide et plus facile.

**Personas recomendadas
para el montaje**

¡Hágalo en equipo!
Llame a un amigo para que el montaje
sea más rápido y sencillo.

Outils nécessaires

Munis-toi d'un tournevis cruciforme pour réaliser cet assemblage. Tu auras également besoin d'un marteau pour t'aider.

Herramientas requeridas

Tome un destornillador Phillips pour conquister ce conjunto. También necesitaremos un martillo para ayudar

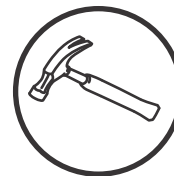
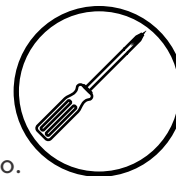

Utilise les outils électriques avec précaution

Ce meuble est réalisé en Bois Massif et Bois Composite, des matériaux souples. Si tu choisis d'utiliser des outils électriques, règle-les sur le mode le plus lent. Fais attention à toi ! Les outils électriques peuvent provoquer des fissures ou endommager les meubles, mais aussi les autres composants s'ils sont mal utilisés. Les dommages causés par un outil électrique ne sont pas couverts par la garantie .

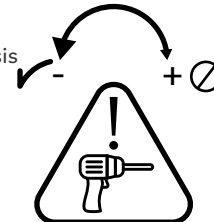

Utilice las herramientas eléctricas con cuidado

Este mueble está fabricado con madera maciza y madera compuesta, materiales blandos. Si decide utilizar herramientas eléctricas, ajústelas al ajuste más lento. Tenga cuidado. Las herramientas eléctricas pueden causar grietas o daños en el mueble, pero también en los herrajes si se utilizan mal. Los daños causados por una herramienta eléctrica no están cubiertos por la garantía .







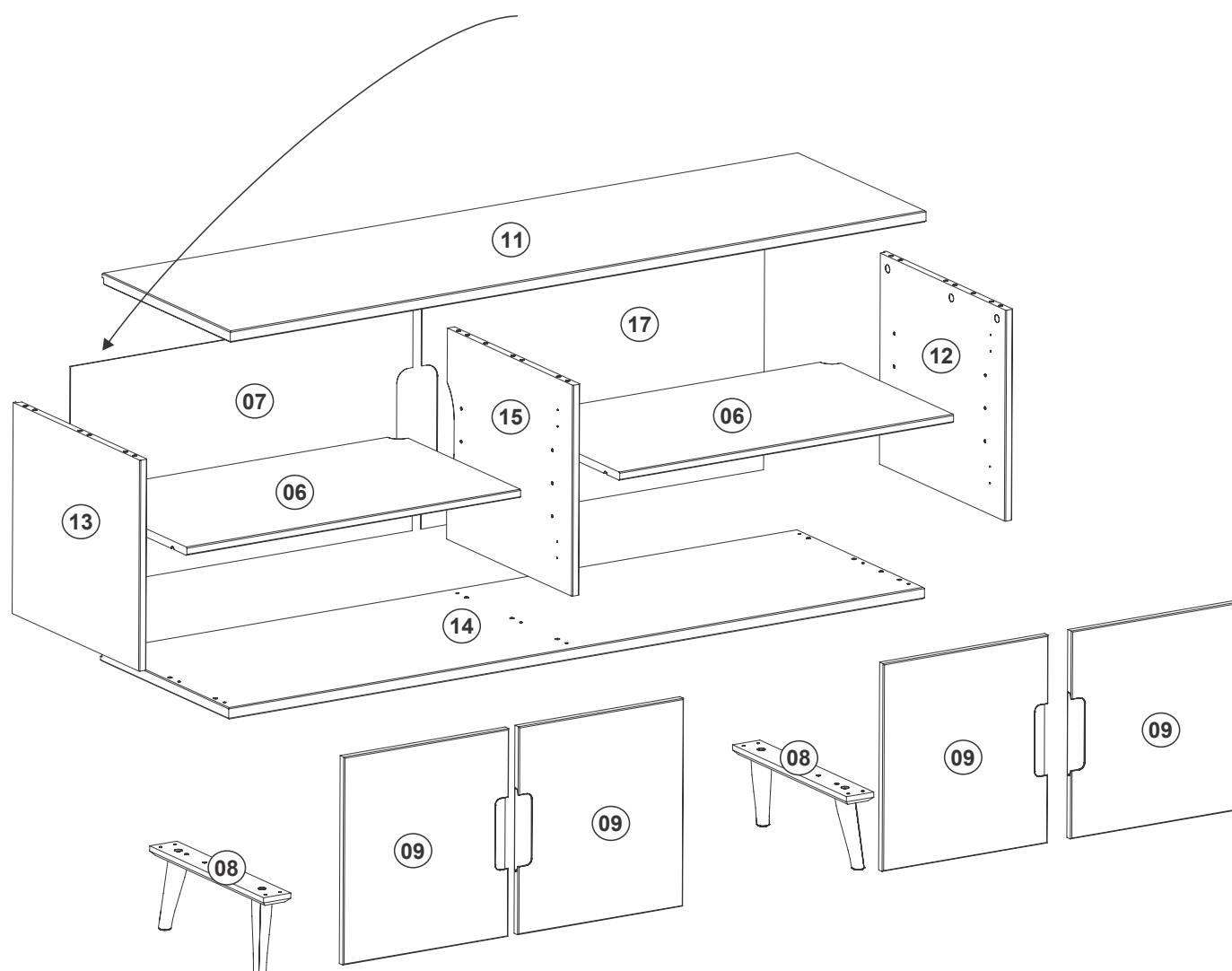



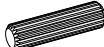



Liste de pièces / Lista de piezas

Nombre de pièces Número de pieza	Description Descripción	Quantité Cantidad
06	Etagère Estante	02
07	Arrière Gauche Trasero Izquierdo	01
08	Pied Pies	02
09	Porte Puerta	04
11	Panneau Supérieur Panel Superior	01

Nombre de pièces Número de pieza	Description Descripción	Quantité Cantidad
12	Panneau Droit Panel Derecho	01
13	Panneau Gauche Panel Izquierdo	01
14	Panneau Inférieur Panel Inferior	01
15	Panneau Central Panel Central	01
17	Arrière Droit Panel Derecho	02



Liste de composants / Lista de hardware

	Partie Parte	Taille Tamaño	Nom Nombre	Quantité Cantidad
A		8x30mm	Chevile en bois Espiga de madeira	25
B		3.5x14mm	Vis Tornillo	36
C		3.5x30mm	Vis Tornillo	12
D		4x40mm	Vis Tornillo	10
E		6x8mm	Support Soporte	08
F		5x24mm	Goujon Conector	09
G		15x12mm	Boitier Traba	09
H			Serrure Arrière Traba Trasera	04
I		20x8mm	Clou de fixation Clavo de Fijacion	02
J		8x8mm	Clou Clavo	30
K		4x16mm	Vis Tornillo	01
L		6x35mm	Douille Casquillo	01
M			Rondele Arandela	02
N			Ruban Cinta	01
O			Charnière Bisagra	08

Les quantités de composants indiquées ci-dessus sont nécessaires pour un assemblage correct.
Des pièces supplémentaires peuvent être incluses.

Las cantidades de tornillería indicadas anteriormente son necesarias para un montaje correcto.
Se pueden incluir piezas de ferretería adicionales.

Étape / Paso 1

(FR)

Insérez la Cheville (A) dans les Pieds (08), Panneau Droit (12), Panneau Gauche (13) et Panneau Central (15).

(ES)

Inserte la Espiga (A) en los Pies (08), Panel Derecho (12), Panel Izquierdo (13) y en el Panel Central (15).

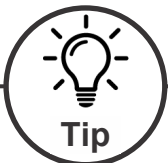
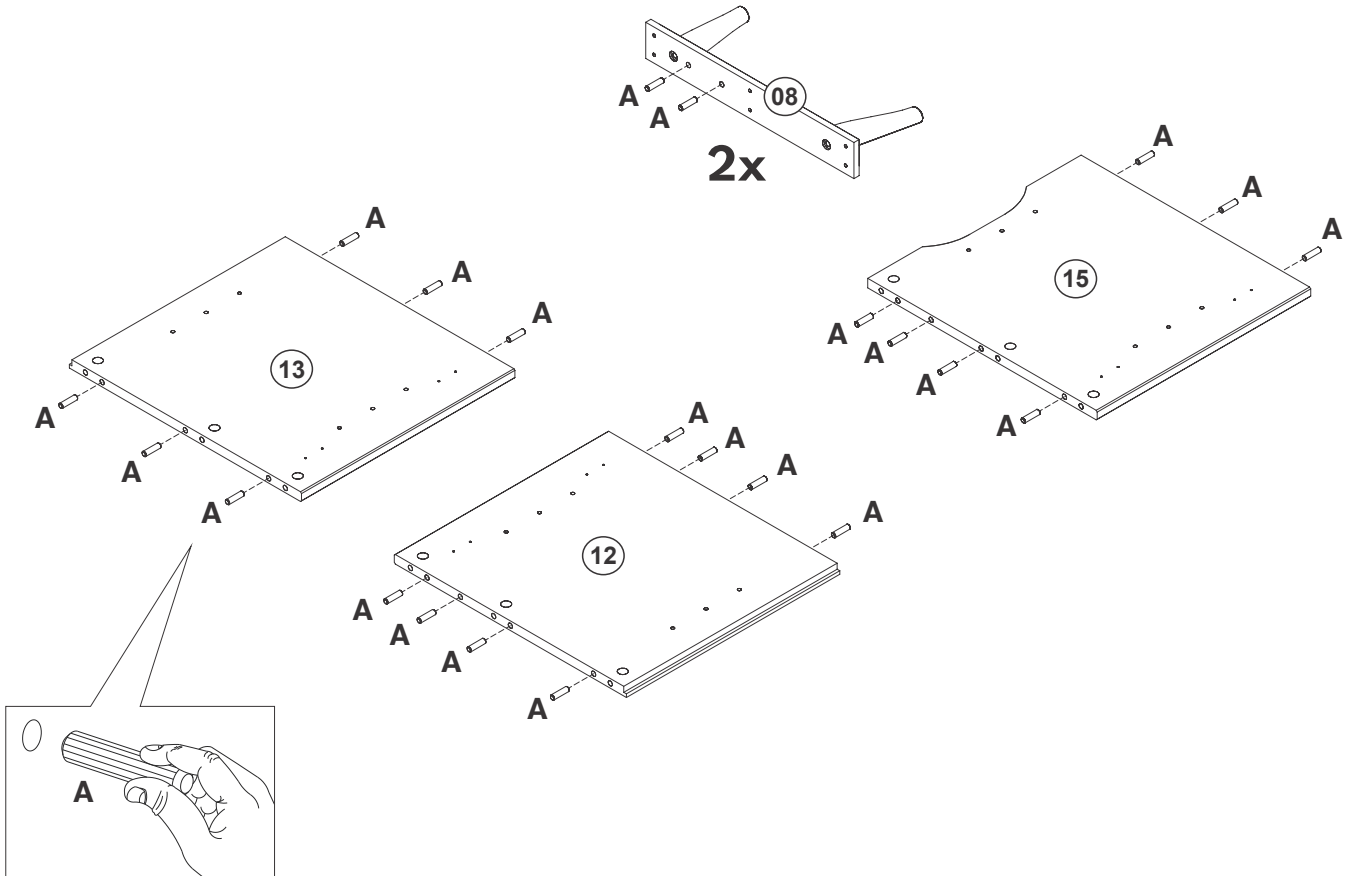
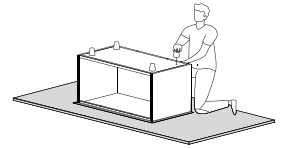

Les chevilles sont essentielles lors de l'assemblage de meubles pour créer des connexions solides et précises. Elles garantissent l'intégrité structurelle, empêchent les déplacements et simplifient l'alignement, ce qui permet d'obtenir des meubles plus résistants et plus durables. Suis ces étapes:

Las espigas son esenciales en el montaje de muebles para crear uniones fuertes y precisas. Garantizan la integridad estructural, evitan el desplazamiento y simplifican la alineación, lo que se traduce en muebles más resistentes y duraderos. Sigue estos pasos:

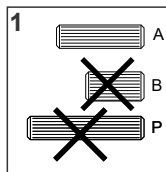

1: Sélectionne la taille de cheville appropriée en fonction de l'étape.
1: Seleccione el tamaño de espiga adecuado según el paso.

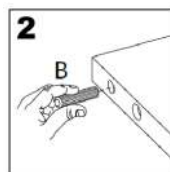

2: Insère dans le trou indiqué et appuie fermement pour assurer un positionnement correct.
2: Insértela en el orificio indicado y presione firmemente para asegurar su correcta colocación.

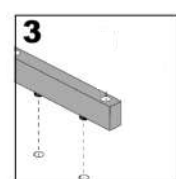
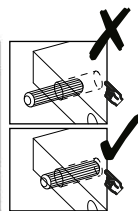

3: Aline la cheville avec la pièce correspondante et enfonce-la jusqu'à ce qu'elle soit ferme.
3: Alinee el pasador con la pieza correspondiente y presiónelo hasta que encaje

Étape / Paso 2

(FR)

Insérez le Support d'Étagère (E) dans les trous du Panneau droit (12), Panneau gauche (13) et du Panneau Central (15).

(ES)

Inserte el Soporte del Estante (E) en los orificios del Panel derecho (12), Panel Izquierdo (13) y el Panel Central (15).

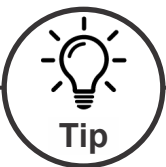
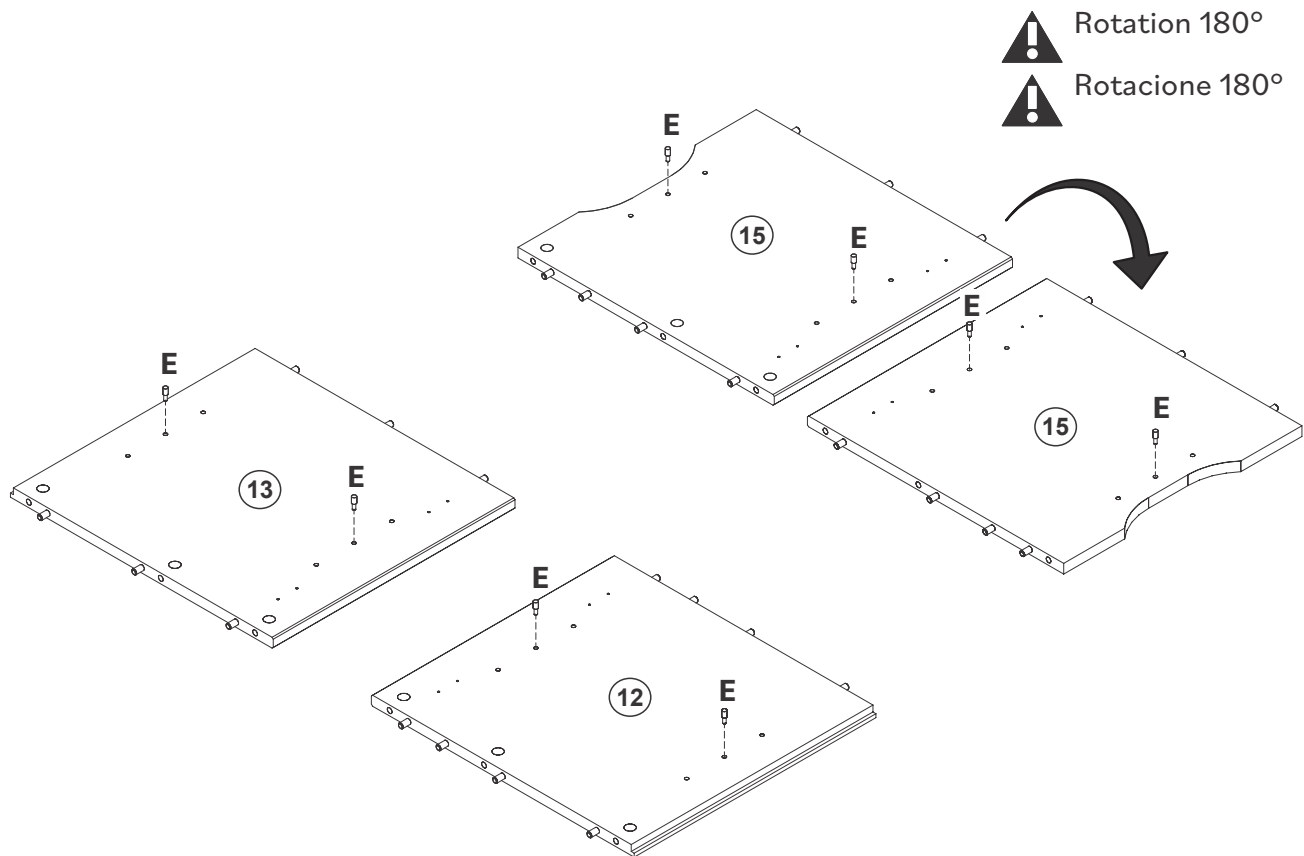

Tip

Pour que ton produit conserve son meilleur aspect et sans rayures, essaie de le monter sur une surface souple telle qu'un tapis ou une couverture. Cela permet d'éviter les rayures accidentelles et de garder tes meubles en bon état!

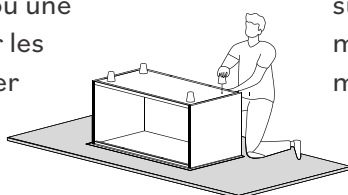

Para mantener su producto con el mejor aspecto y sin arañazos, pruebe a montarlo sobre una superficie blanda, como una alfombra o una manta. Así evitará arañazos accidentales y mantendrá sus muebles en perfecto estado.

Étape / Paso 3

(FR)

Fixez la Goujon(F) dans les trous du Panneau Supérieur (11) à l'aide d'un tournevis cruciforme.

(ES)

Fije el Conector (F) en los orificios del Panel Superior (11) utilizando un destornillador Phillips.

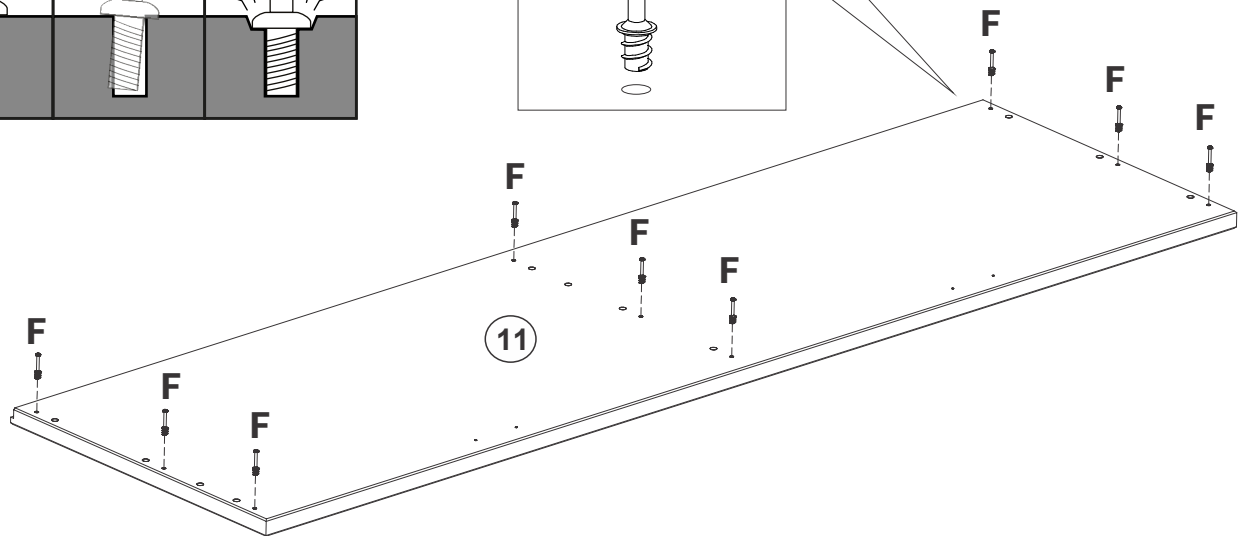
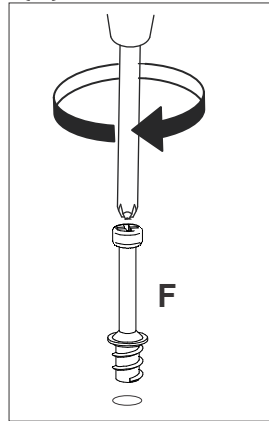
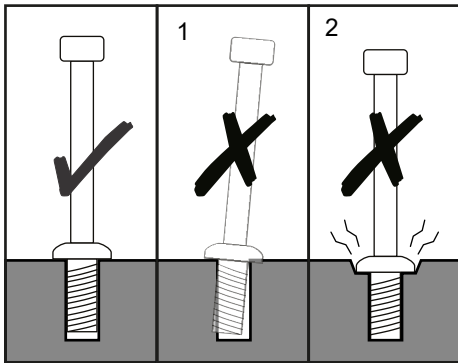
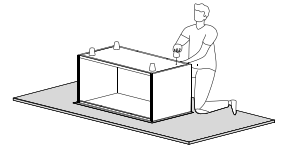

Étape / Paso 04

(FR)

Fixez le Dispositif arrière (H) au Panel Supérieur (11) avec la Vis (B) et un tournevis cruciforme.

(ES)

Asegure el Dispositivo Trasero (H) a la Panel Superior (11) con el Tornillo (B) y un destornillador Phillips.

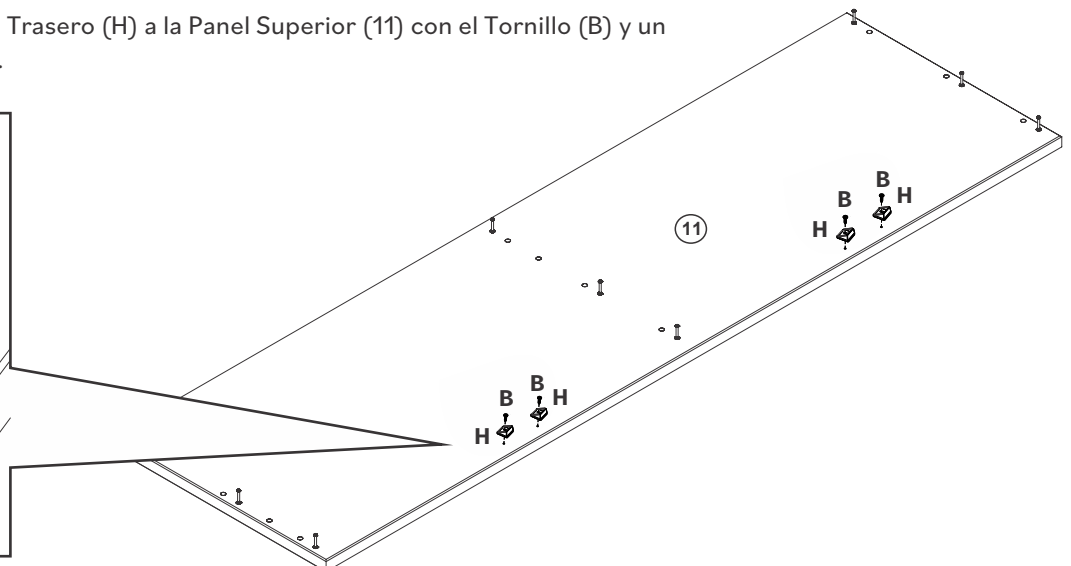
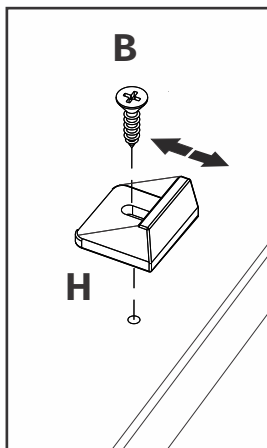

Étape / Paso 5

(FR)

Montez les Pieds (08) sur le Panneau Inférieur (14). Insérez la Vis (C) dans le trou des Pieds (08) et fixez-les avec un tournevis cruciforme.

(ES)

Coloque los Pies (08) en el Panel Inferior (14). Inserte el Tornillo (C) en el orificio de los Pies (08) y asegúrelo con un destornillador Phillips.

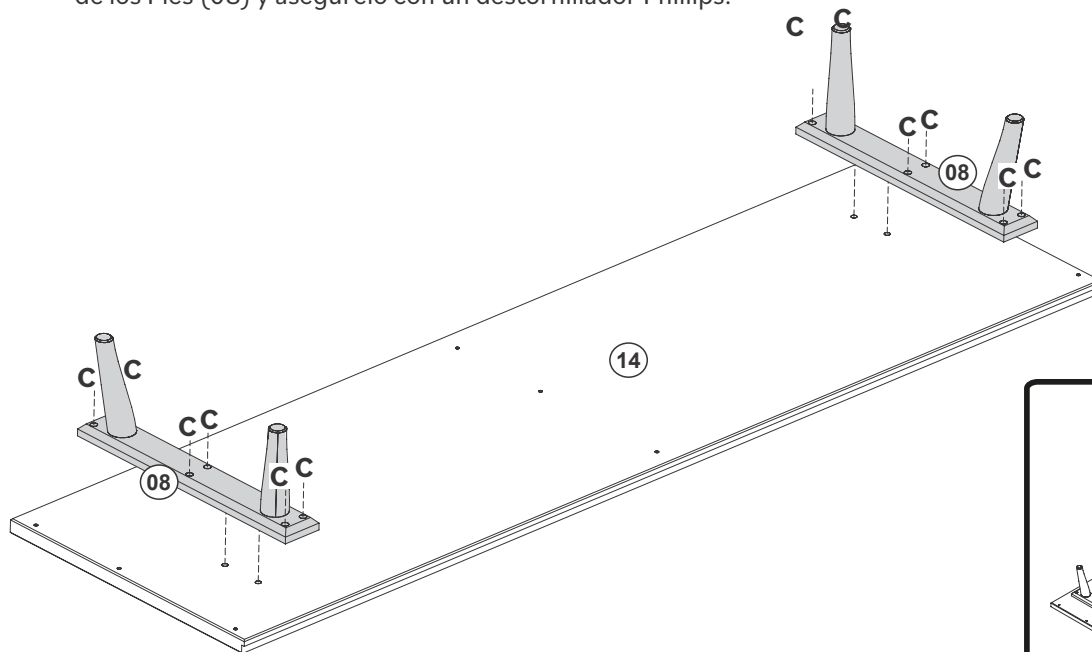
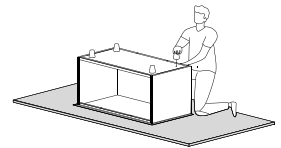

Étape / Paso 06

(FR)

Fixez le Panneau Droit (12), Panneau Gauche (13) et le Panneau Central (15) au Panneau Inférieur (14) avec une Vis (D) et un tournevis cruciforme.

(ES)

Conecte el Panel Derecho (12), Panel Izquierdo (13) y el Panel Central (15) al Panel Inferior (14) con el Tornillo (D) y un destornillador Phillips.

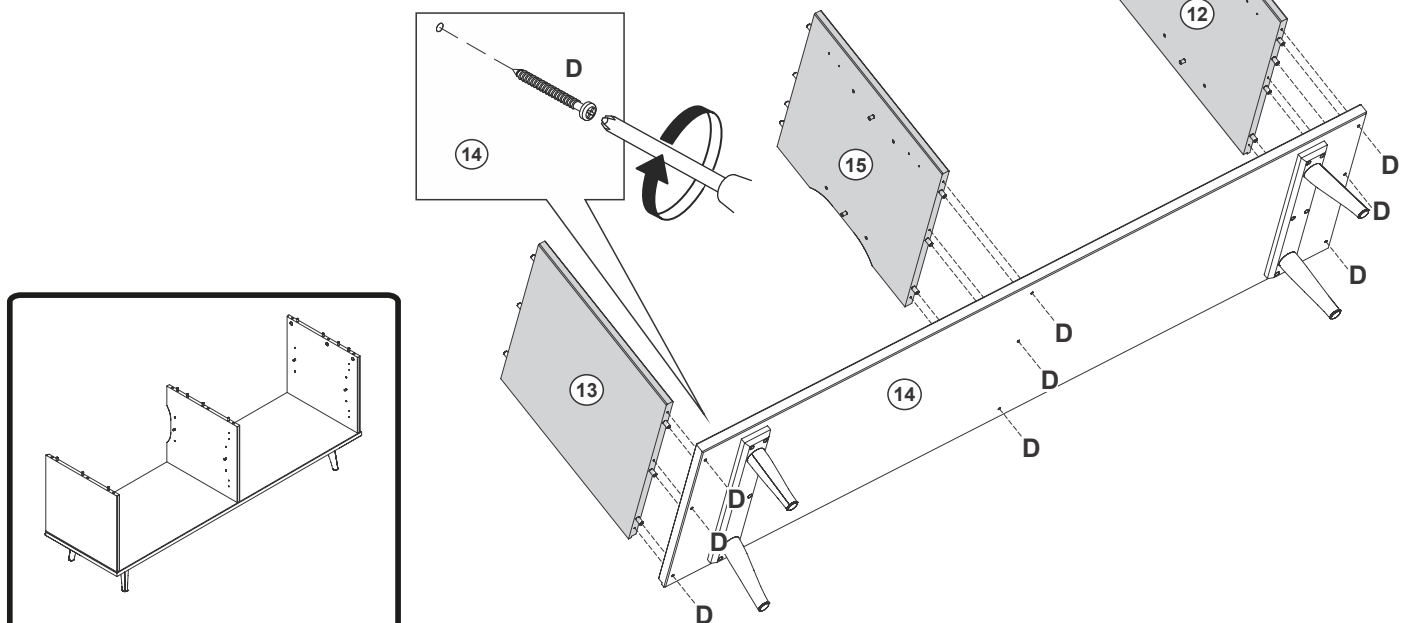

Étape / Paso 7

(FR)

Montez le Panneau Supérieur (11) sur le Panneau Droit (12), Panneau Gauche (13) et le Panneau Central (15). Insérez la Vis (G) et fixez-la avec un tournevis cruciforme.

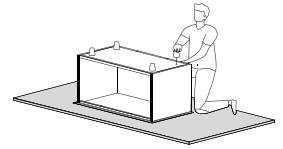

(ES)

Coloque el Panel Superior (11) en el Panel Derecho (12), Panel Izquierdo (13) y el Panel Central (15). Inserte el Tornillo (G) y asegúrelo con un destornillador Phillips.

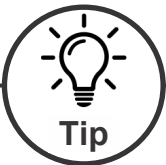
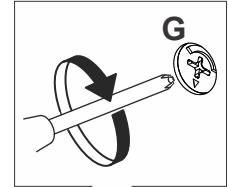
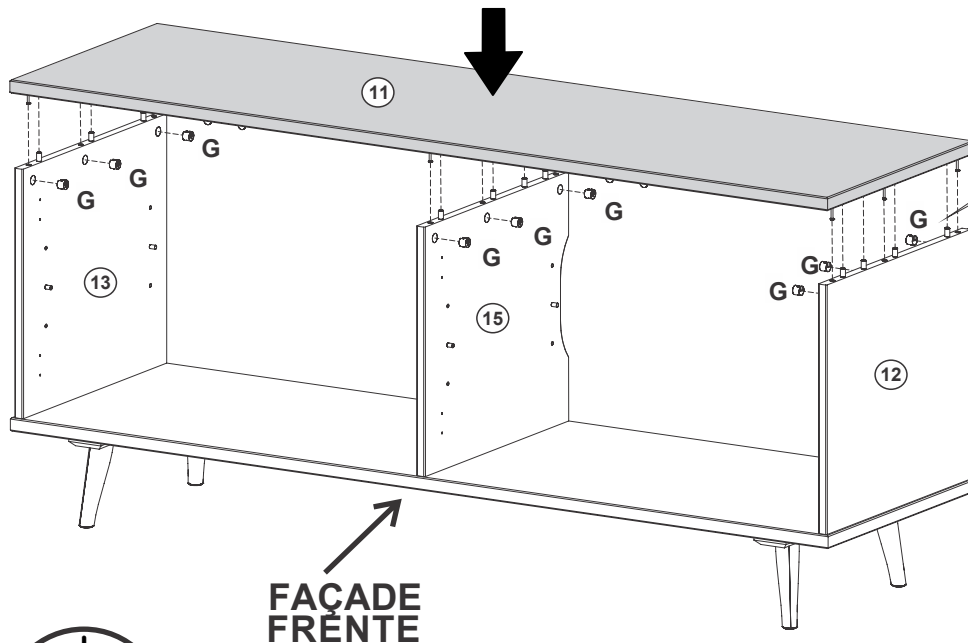

Tip

Goujon

Goujon permet de joindre deux pièces en toute sécurité. Suis ces étapes simples.

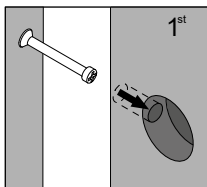

1: Insère le Goujon dans les orifices du côté plat. Ne serre pas trop !
1: Coloca el Conector en los orificios del lado plano. ¡No aprietes demasiado!

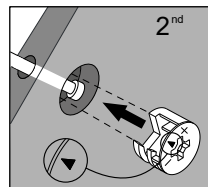

2: Joins les pièces en bois. Les Goujon entrent dans les orifices qui ont des trous sur les côtés, tu dois pouvoir voir les Goujons à travers ceux-ci. Après avoir installé les pièces, insère le Boitier dans les orifices latéraux
2: Una las piezas de madera. Los Conectores entran en las piezas que tienen orificios en los lados, por lo que deberías poder ver los Conectores a través de ellos. Después de encajar las piezas, inserta la Traba en los orificios laterales.

Conector

Los Conectores ayudan a unir de forma segura dos piezas. Sigue estas fáciles etapas.

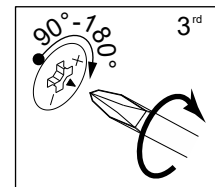

3: Sur la partie arrière du Boitier, il aura la forme d'un « C ». Insère le Boitier de manière à ce que l'ouverture « C » s'emboîte à la Goujon. Serre-la avec le tournevis.
3: La parte posterior de la Traba tendrá la forma de "C". Inserta la Traba de modo que la abertura de la "C" encaje en el Conector. Apriétalo con un destornillador.

Étape / Paso 8

(FR)

Fixez l'Arrière Gauche (07) et l'Arrière Droit (17) au Panneau Supérieur (11), Panneau Droit (12), Panneau Gauche (13) et Panneau Inférieur (14) avec des Clous (J) et un marteau. Ensuite, fixez l'Arrière Gauche (07) et l'Arrière Droit (17) avec les Clous de fixation (I) et un marteau.

(ES)

Fije el Panel Trasero Izquierdo (07) y el Panel Trasero Derecho (17) al Panel Superior (11), Panel Derecho (12), Panel Izquierdo (13) y Panel Inferior (14) con Clavos (J) y un martillo. Luego, fije el Trasero Izquierdo (07) y el Trasero Derecho (17) con los clavos de fijación (I) y un martillo.

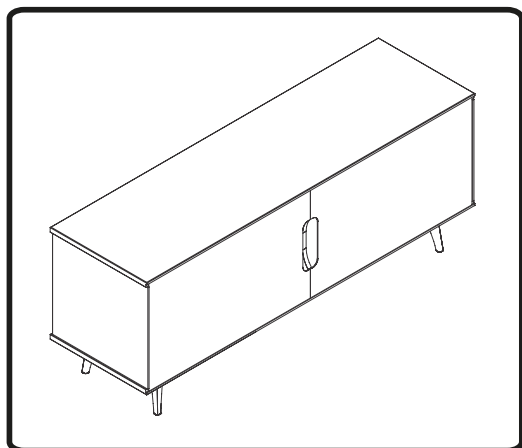
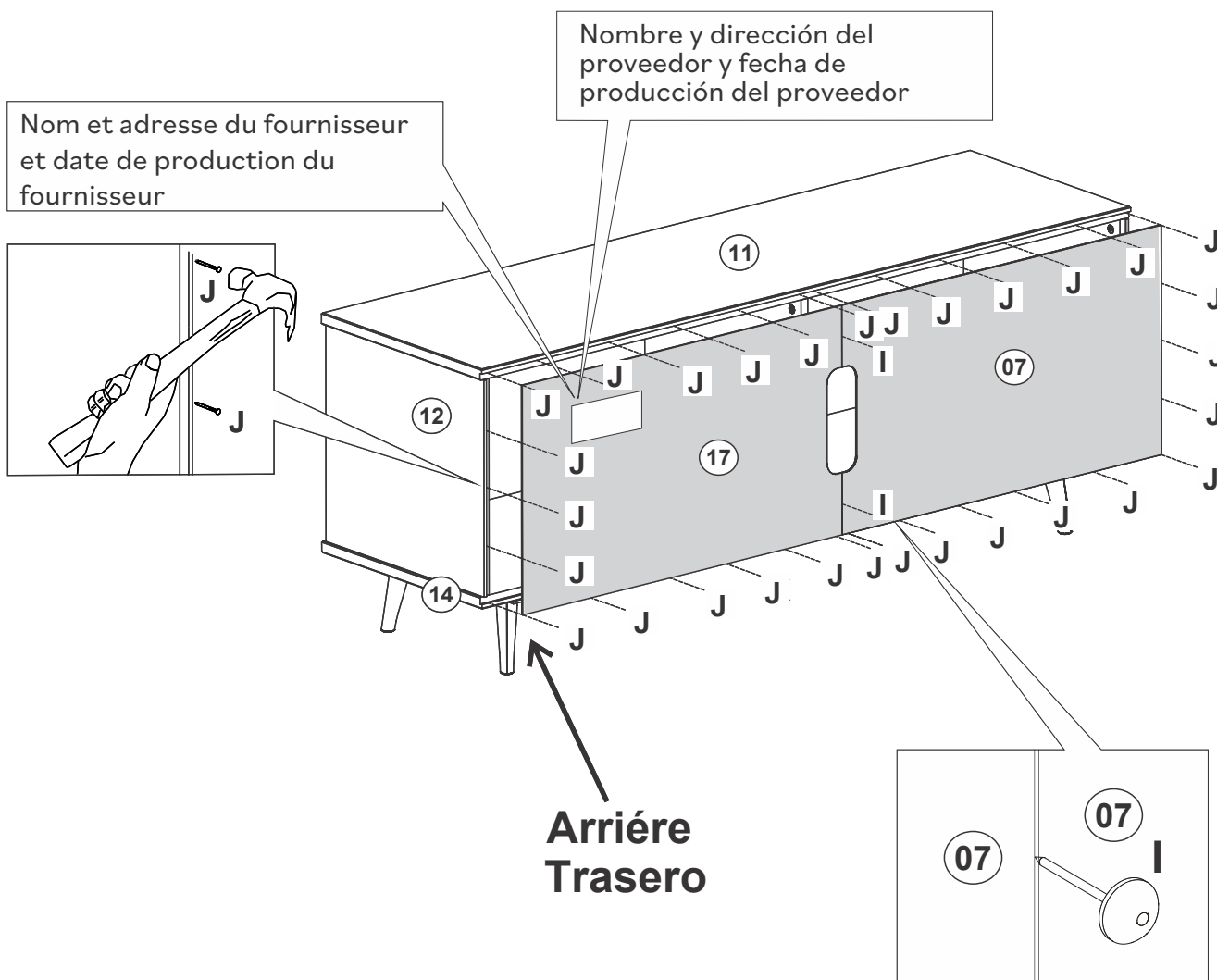
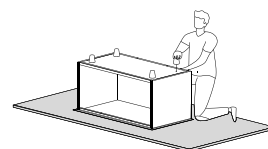

Étape / Paso 9

(FR)

Montez les étagères (06) sur le support d'étagère.

(ES)

Coloque los estantes (06) en el soporte del estante.

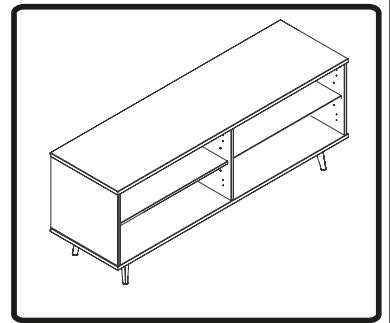
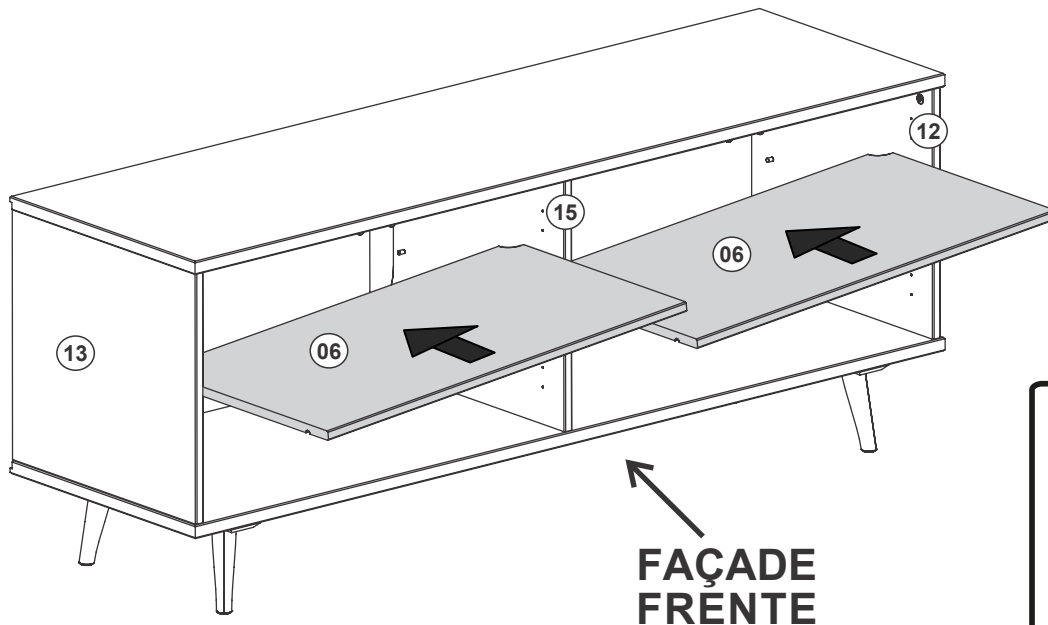
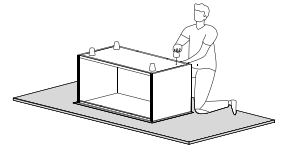

Étape / Paso 10

(FR)

Fixez la Charnière (O) dans les trous de la Porte (09) avec la vis (B) et un tournevis cruciforme.

(ES)

Fije la Bisagra (O) en los agujeros de la Puerta (09) con el tornillo (B) y un destornillador Phillips.

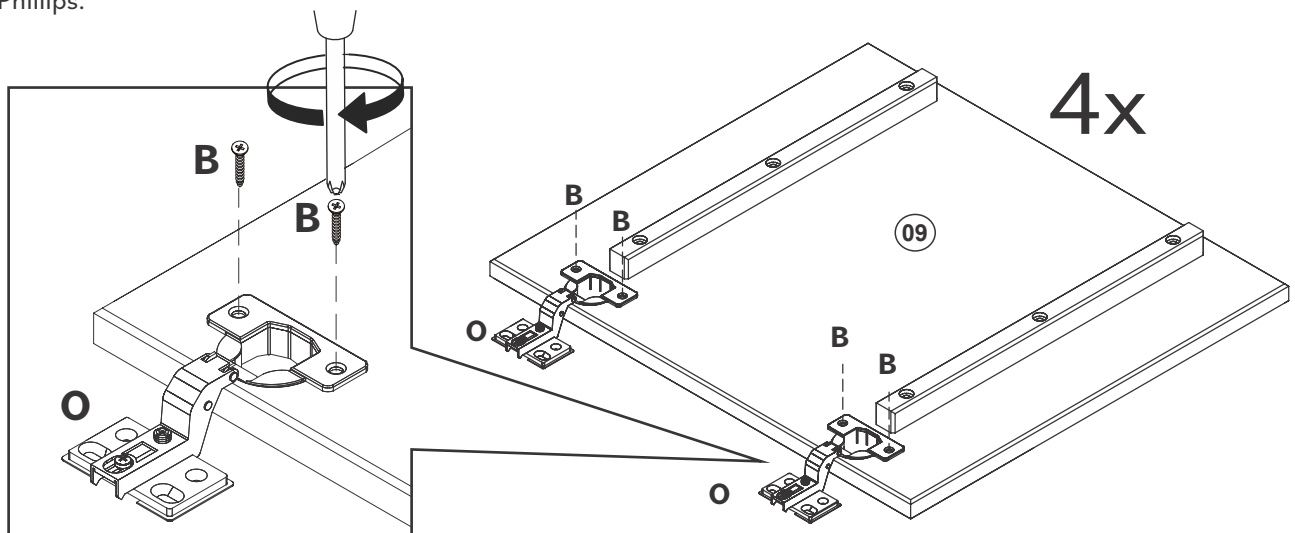

Étape / Paso 11

(FR)

Fixez les portes (09) au panneau droit (12), au panneau gauche (13) et au panneau central (15) avec une vis (B) et un tournevis cruciforme.

(ES)

Asegure las puertas (09) al panel derecho (12), panel izquierdo (13) y panel central (15) con el tornillo (B) y un destornillador Phillips.

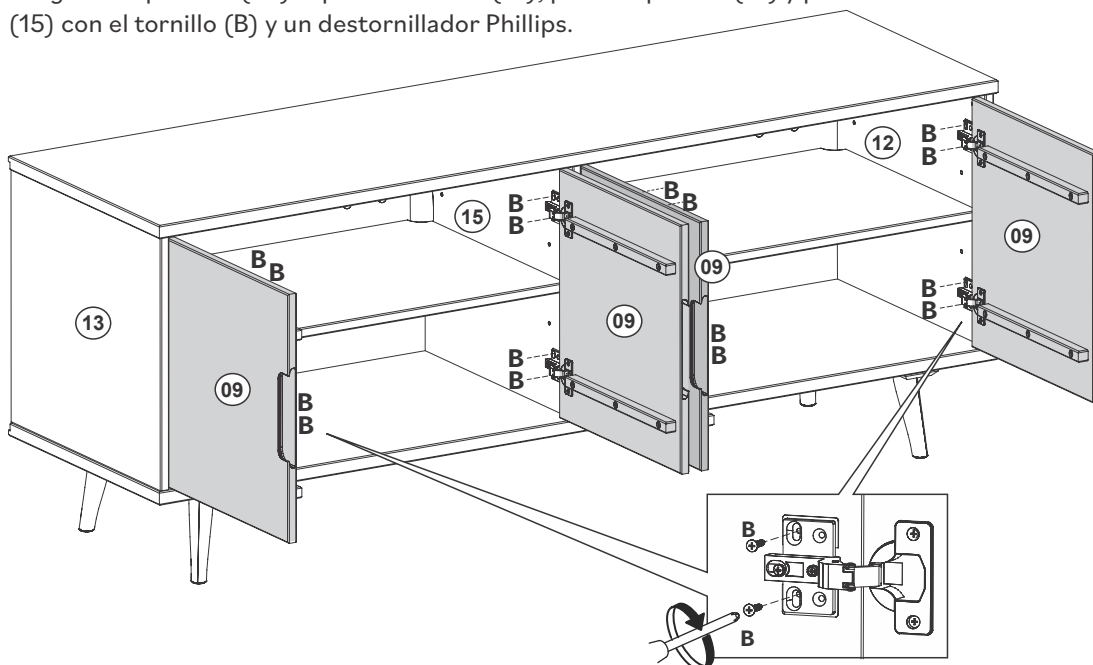
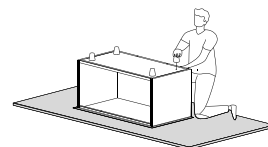

Étape / Paso 12

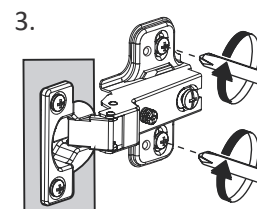
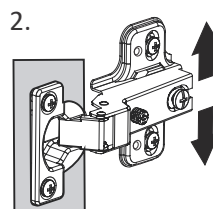
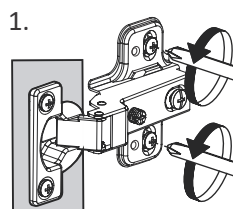
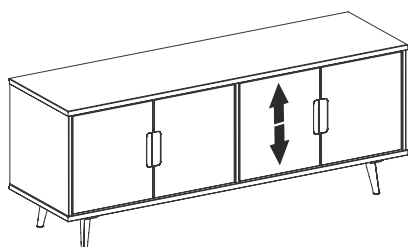

La porte s'ajuste de haut en bas en desserrant les vis du haut et du bas /
La puerta se ajusta hacia arriba y hacia abajo aflojando los tornillos superiores e inferiores.

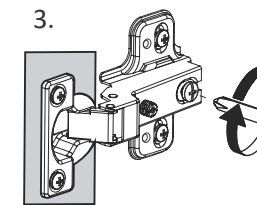
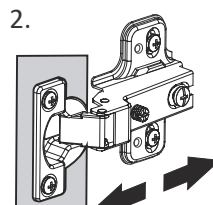
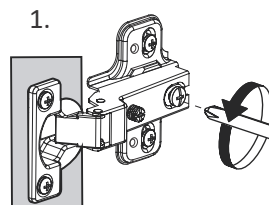
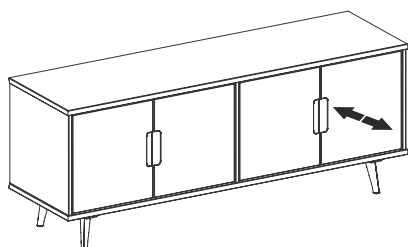

Desserrez la vis arrière pour régler la porte vers l'avant et vers l'arrière / Afloje el tornillo trasero para ajustar la puerta hacia adelante y hacia atrás.

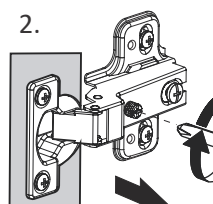
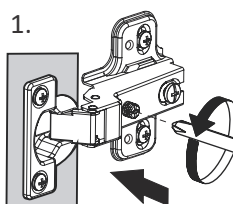
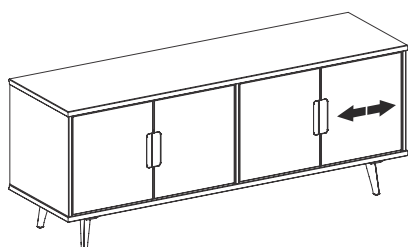

Ajustez la distance de la porte par rapport au panneau latéral avec la vis centrale /
Ajuste la distancia de la puerta desde el panel lateral con el tornillo central

Étape / Paso 13

(FR)

Enfin, fixons la Support TV au mur ! Fixez l'Ruban (N) à la support TV à l'aide de la Rondelle (M) et d'une vis (K)

(ES)

¡Por último, fijemos la TV Stand a la pared! Fije la Cinta (N) a la TV stand usando la Arandela (M) y un Tornillo (K.)

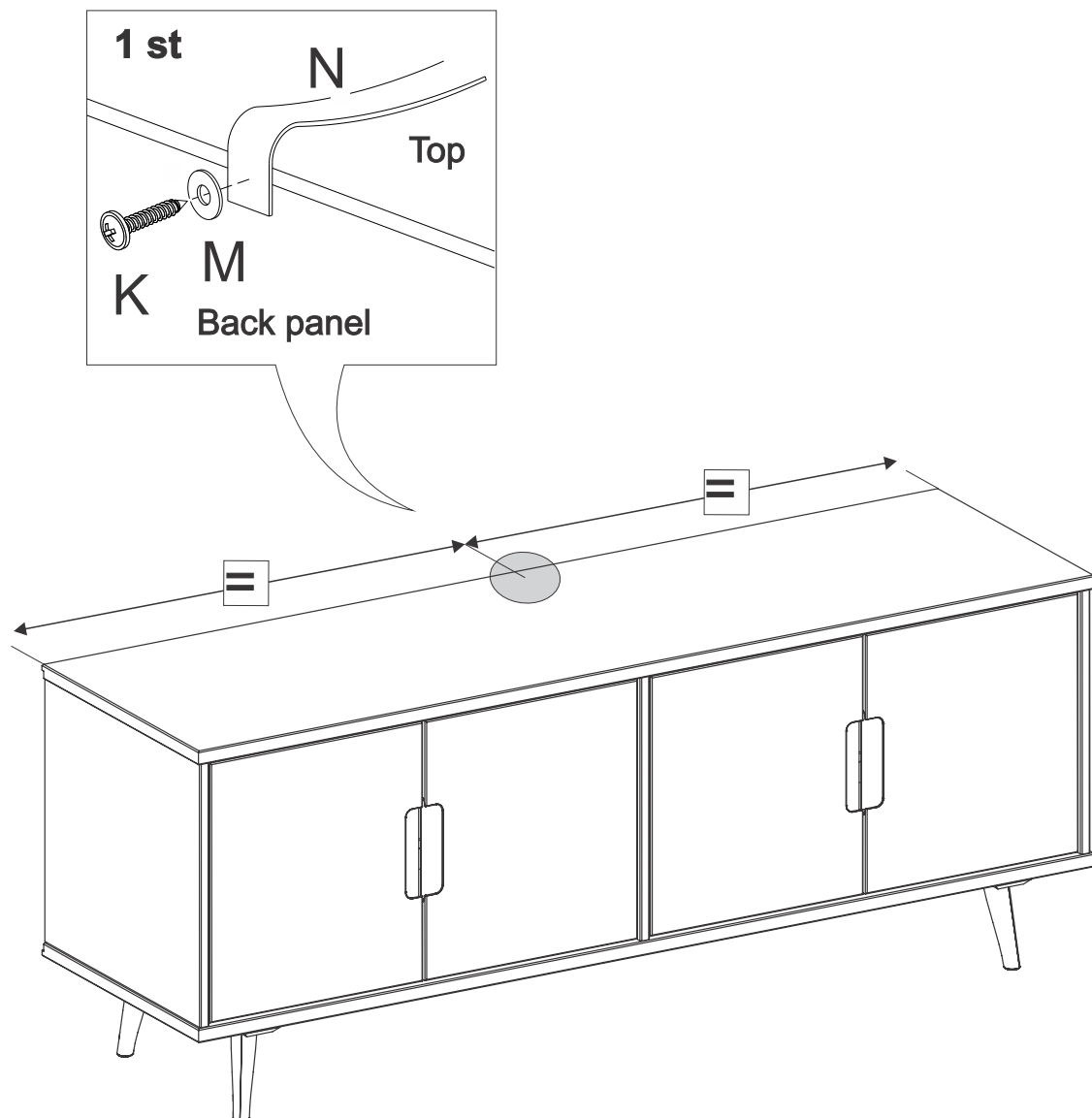

Étape / Paso 13

(FR)

Insérez la Douille (L) dans le mur. Fixez ensuite l'Ruban (N) au mur à l'aide d'une rondelle (M) et d'une vis (D).

(ES)

Inserte el Casquillo (L) en la pared. Luego fije la Cinta (N) a la pared usando una arandela (M) y un tornillo (D).

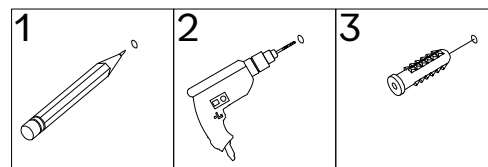
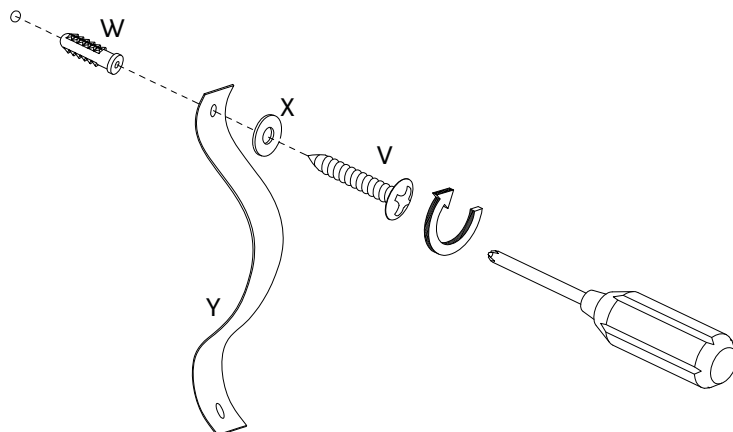

AVERTISSEMENT

Des blessures graves, voire mortelles, peuvent survenir en cas de renversement. Pour éviter le renversement, installez les dispositifs de retenue selon les instructions. Si vous l'utilisez pour prendre en charge un téléviseur ou un moniteur :

- La mort ou des blessures graves peuvent survenir lorsque des enfants grimpent sur des meubles d'équipement audio/vidéo. Des télécommandes ou des jouets placés sur le meuble peuvent inciter un enfant à grimper sur le meuble et par conséquent sur le meuble.
- Ne placez pas le téléviseur près du bord avant du produit.

Pour réduire davantage le risque de blessures graves et de décès dus à un renversement :

- Placez les objets les plus lourds dans les compartiments ou tiroirs les plus bas.
- Ne laissez jamais les enfants grimper ou s'accrocher aux tiroirs, aux portes ou aux étagères.
- N'ouvrez jamais plus d'un tiroir à la fois.

L'utilisation de dispositifs de sécurité en cas de basculement peut seulement réduire, mais pas éliminer, le risque de basculement.

Pour un montage sûr, il est essentiel d'utiliser des ancrages muraux adaptés à votre type de mur (c'est-à-dire plâtre, cloison sèche, béton, etc.). Montez sur des montants en bois autant que possible. Remarque : si vous n'êtes pas sûr de votre type de mur ou de la méthode de montage que vous devez utiliser, consultez un professionnel qualifié ou votre quincaillerie locale.

Informations sur le nom et l'adresse du fabricant responsable du matériel anti-basculement et la date de production se trouvent sur l'étiquette au dos du meuble.

Información de nombre y dirección del fabricante responsable del hardware antivuelco y la fecha de producción se pueden encontrar en la etiqueta en la parte posterior del mueble.

ADVERTENCIA

En caso de vuelco se pueden producir lesiones por aplastamiento graves o mortales. Para ayudar a evitar vuelcos, instale restricciones de vuelco según las instrucciones. Si lo utiliza como soporte para un televisor o monitor:

- Pueden producirse muertes o lesiones graves cuando los niños se suben a los muebles de equipos de audio o vídeo. Los controles remotos o los juguetes colocados sobre los muebles pueden alentar al niño a subirse a los muebles y, como resultado, a los muebles.
- No coloque el televisor cerca del borde frontal del producto.

Para reducir aún más el riesgo de lesiones graves y muerte por vuelcos:

- Coloque los artículos más pesados en los compartimentos o cajones más bajos.
- Nunca permita que los niños trepen o se cuelguen de cajones, puertas o estantes.
- Nunca abra más de un cajón a la vez.

El uso de dispositivos de seguridad contra vuelcos sólo puede reducir, pero no eliminar, el riesgo de vuelco.

Para un montaje seguro, es fundamental utilizar anclajes de pared adecuados para su tipo de pared (es decir, yeso, paneles de yeso, hormigón, etc.). Monte en montantes de madera siempre que sea posible. Nota: si no está seguro del tipo de pared o del método de montaje que debe utilizar, consulte a un profesional cualificado o a su ferretería local.

**Vous avez réussi ! Profitez de votre nouvelle TV Stand !
Lo has conseguido! Disfruta de tu nuevo TV Stand!**

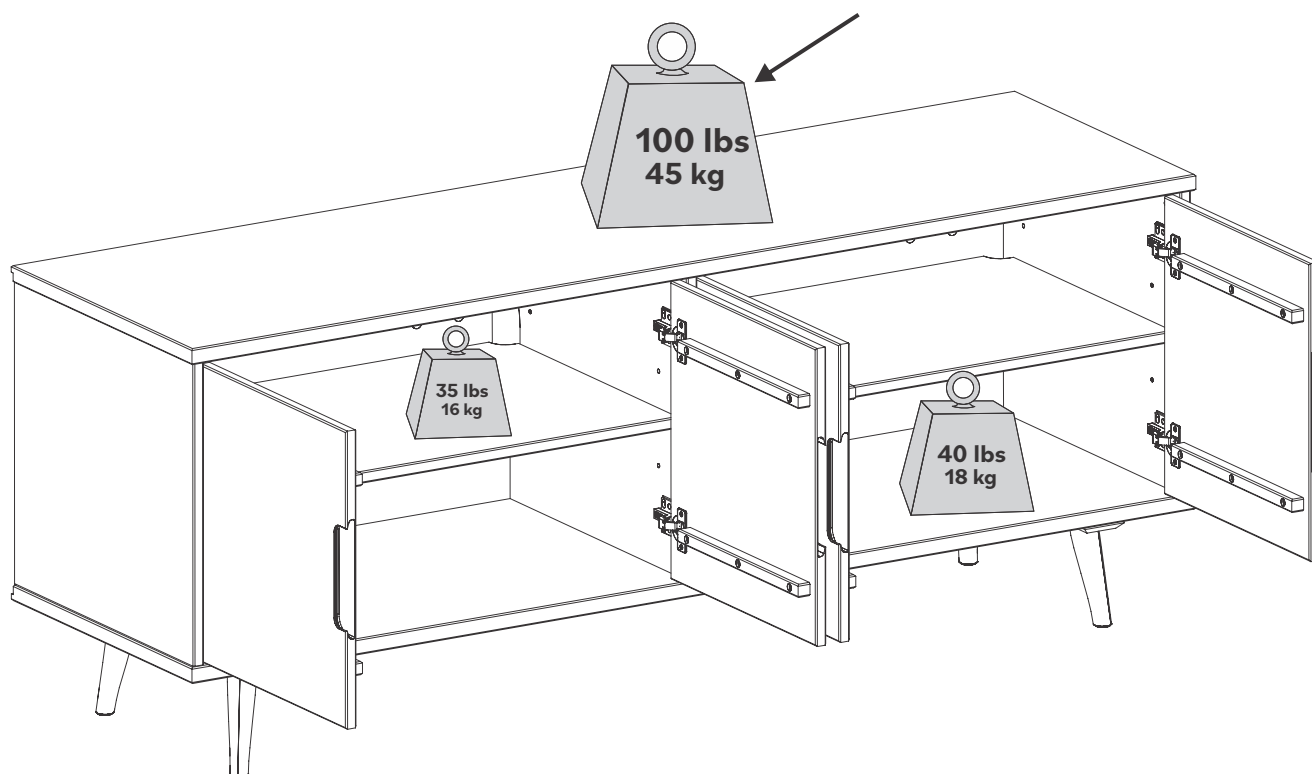

Assembler des meubles peut parfois être compliqué.

Notre équipe de service client, est là pour obtenir des informations sur les produits, aider pour l'assemblage d'un produit ou pour tout autre problème de support client.



Pour le nettoyage, n'utilise jamais d'abrasifs, utilise un chiffon doux et de l'eau avec du savon neutre pour nettoyer les meubles

A veces, montar muebles puede resultar complicado.

Nuestro equipo de atención al cliente, está a su disposición para informarle sobre los productos, ayudarle a montarlos o resolver cualquier otro problema de atención al cliente.



Para la limpieza, nunca utilice productos abrasivos, utilice un paño suave y agua con jabón neutro para limpiar los muebles.