

ASSEMBLY INSTRUCTION

SKU CODE: (N709P288890K,N709P288891K)

INSTRUCTIONS DE MONTAGE

SKU NUMBER: (N709P288890K,N709P288891K)

WARDROBE-D10

ARMOIRE-D10

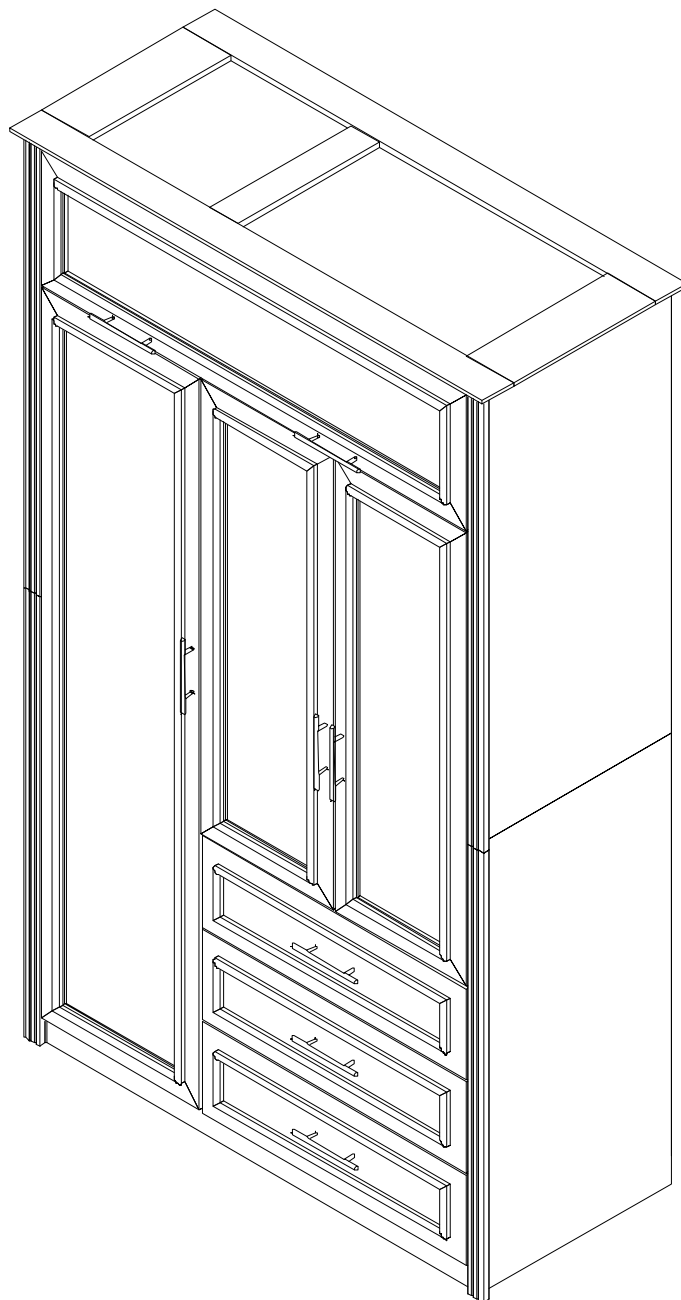

ASSEMBLY INSTRUCTION

INSTRUCTIONS DE MONTAGE

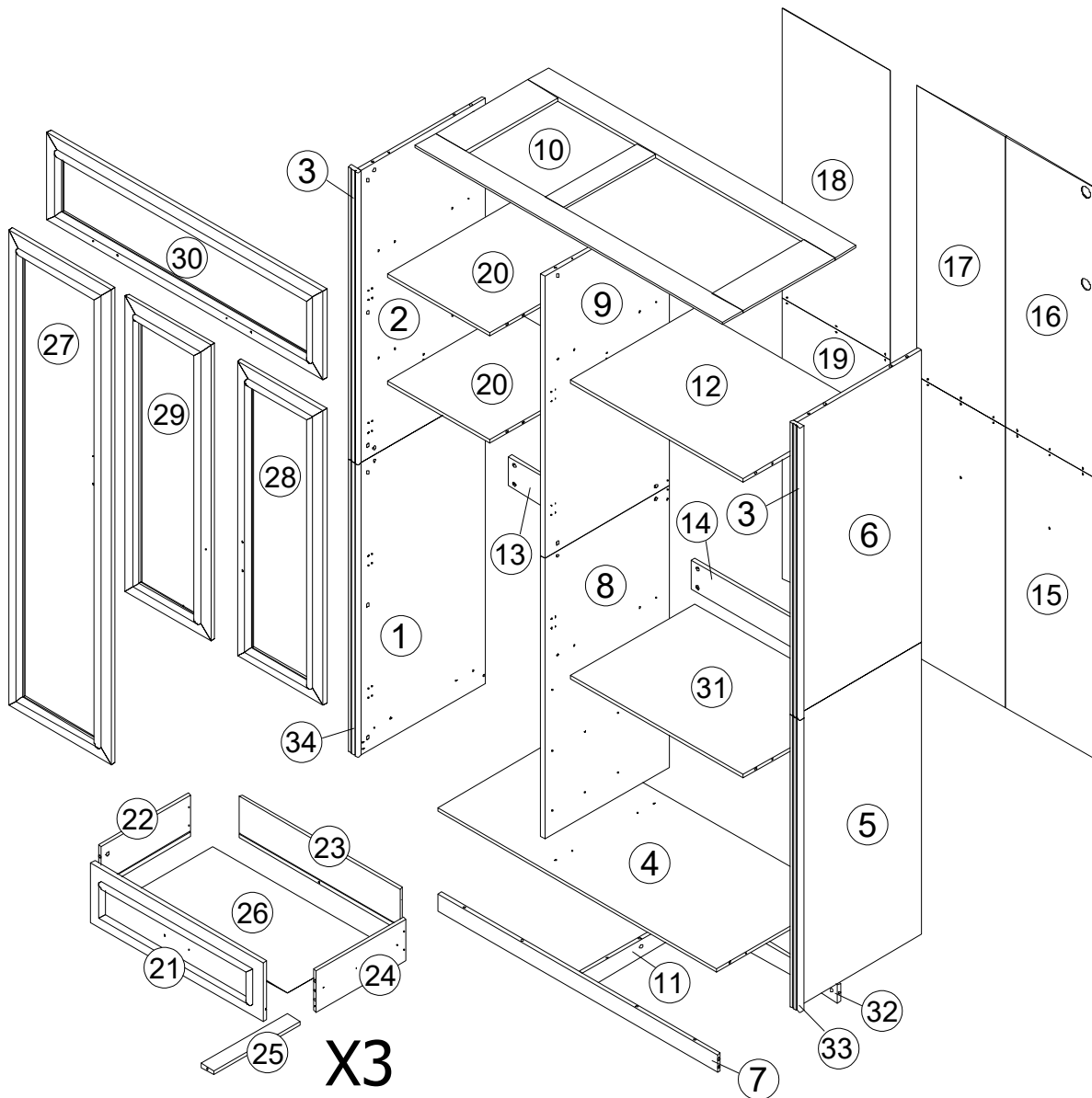

Part List & Hardware List (N709P288890K)

Liste des pièces et liste du matériel

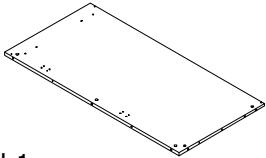
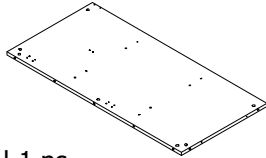
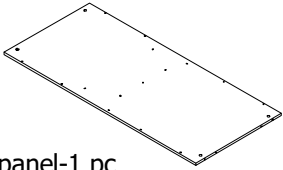
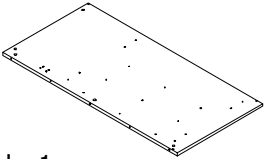
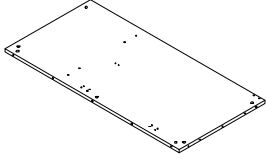
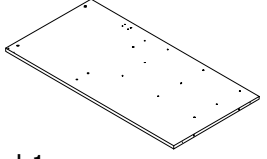
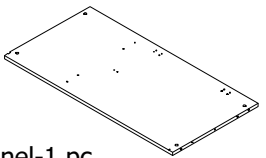
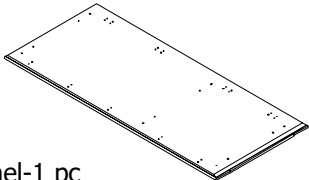
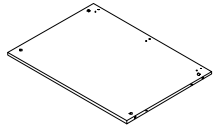
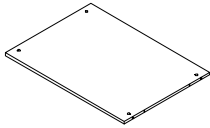
<p>1</p>  <p>Side panel l-1 pc Panneau latéral l</p>	<p>2</p>  <p>Side panel l-1 pc Panneau latéral l</p>	<p>4</p>  <p>Bottom panel-1 pc Panneau inférieur</p>
<p>5</p>  <p>Side panel r-1 pc Panneau latéral r</p>	<p>6</p>  <p>Side panel r-1 pc Panneau latéral r</p>	<p>8</p>  <p>Center panel-1 pc Panneau central</p>
<p>9</p>  <p>Center panel-1 pc Panneau central</p>	<p>10</p>  <p>Top panel-1 pc Panneau supérieur</p>	<p>12</p>  <p>Shelf panel-1 pc Panneau d'étagère</p>
<p>31</p>  <p>Left bottom fixed shelf-1 pc Etagère fixe inférieure gauche</p>		

Part List & Hardware List (N709P288891K)

Liste des pièces et liste du matériel

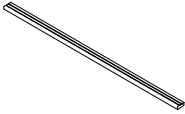
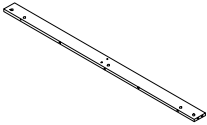
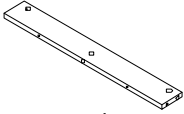
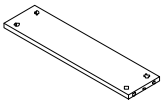
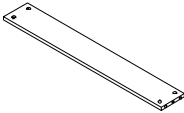
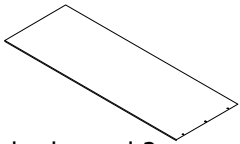
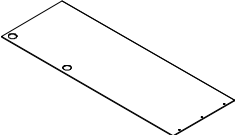
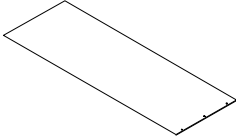
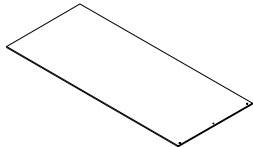
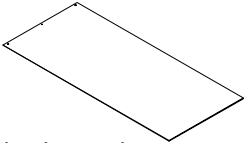
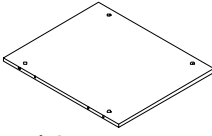
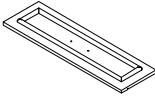
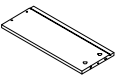
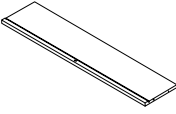
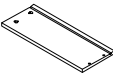
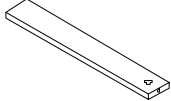
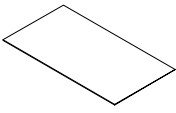
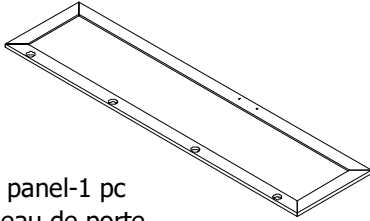
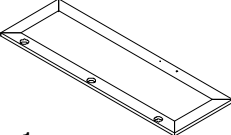
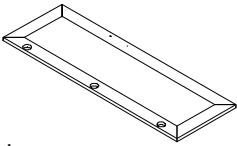
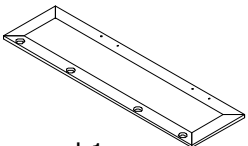
<p>3</p>  <p>Side front-2 pcs Côté avant</p>	<p>7</p>  <p>Bottom side support-1 pc Support latéral inférieur</p>	<p>11</p>  <p>Bottom center support-1 pc Support central inférieur</p>
<p>13</p>  <p>Back panel support-1 pc Support du panneau arrière</p>	<p>14</p>  <p>Back panel support-1 pc Support du panneau arrière</p>	<p>15</p>  <p>Right lower back panel-2 pcs Panneau arrière inférieur droit</p>
<p>16</p>  <p>Right back panel upper-1 pc Panneau arrière droit supérieur</p>	<p>17</p>  <p>Right back panel upper-1 pc Panneau arrière droit supérieur</p>	<p>18</p>  <p>Left back panel upper-1 pc Panneau arrière gauche supérieur</p>
<p>19</p>  <p>Left lower back panel-1 pc Panneau arrière inférieur gauche</p>	<p>20</p>  <p>Left shelf panel-2 pcs Panneau d'étagère gauche</p>	<p>21</p>  <p>Drawer panel-3 pcs Panneau de tiroir</p>
<p>22</p>  <p>Drawer side l-3 pcs Côté tiroir l</p>	<p>23</p>  <p>Drawer back panel-3 pcs Panneau arrière du tiroir</p>	<p>24</p>  <p>Drawer side r-3 pcs Côté tiroir r</p>
<p>25</p>  <p>Drawer bottom support-3 pcs Support de fond de tiroir</p>	<p>26</p>  <p>Drawer bottom-3 pcs Fond de tiroir</p>	<p>27</p>  <p>Door panel-1 pc Panneau de porte</p>
<p>28</p>  <p>Door panel r-1 pc Panneau de porte r</p>	<p>29</p>  <p>Door panel l-1 pc Panneau de porte l</p>	<p>30</p>  <p>Upper door panel-1 pc Panneau de porte supérieur</p>

Part List & Hardware List (N709P288891K)

Liste des pièces et liste du matériel

32

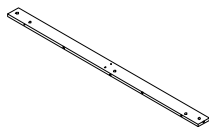

Bottom side support-1 pc
Support latéral inférieur

33

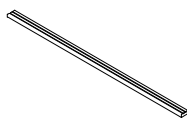

Side front-1 pc
Côté avant



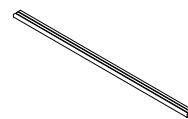



34

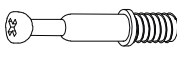
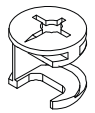

Side front-1 pc
Côté avant

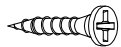
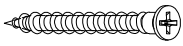
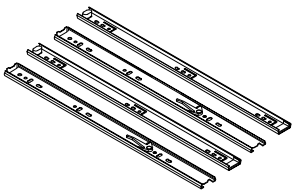
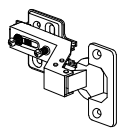
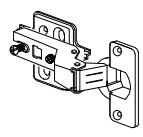
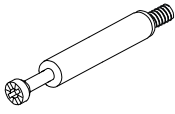
Hardware List (N709P288891K)

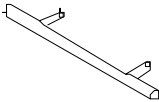
Liste du matériel

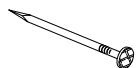
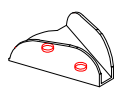
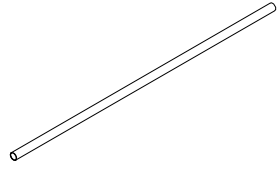
<p>A</p>  <p>Minifix bolt 24mm-74 pcs Boulon Minifix</p>	<p>B</p>  <p>Housing Ø 12mmx10mm-80 pcs Boîtier</p>	<p>C</p>  <p>Dowel M6x30mm-74 pcs Goujon</p>
<p>D</p>  <p>CSK Screw 3.5x14mm-148 Pcs VIS CSK</p>	<p>E</p>  <p>CSK Screw M4X38mm-17 Pcs VIS CSK</p>	<p>F</p>  <p>Drawer slide 2 way 350mm-3 Set Glissière de tiroir</p>
<p>G</p>  <p>Hinges 7/8" soft closing-11 Pcs Charnières 7/8" à fermeture douce</p>	<p>H</p>  <p>Hinges 2/8" soft closing-3 Pcs Charnières 2/8" à fermeture douce</p>	<p>I</p>  <p>Contract Fix Dowel-D7x34mm-6 Pcs Cheville de réparation contractuelle</p>
<p>J</p>  <p>JRN Barrel Nut M6x13mm-6 Pcs Écrou de baril JRN</p>	<p>K</p>  <p>Handle-8 Pcs Poignée</p>	<p>L</p>  <p>Truss Head M4x22mm-16 Pcs Tête de ferme</p>
<p>M</p>  <p>Steel Nail-62 Pcs Clou en acier</p>	<p>N</p>  <p>Hanger-4 Pcs Cintre</p>	<p>O</p>  <p>Pipe Aluminium 19x1x666mm-1 pc Tuyau en aluminium</p>

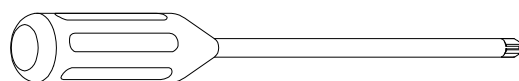

Assembly Tools Required (Not included)
Outils d'assemblage requis (non inclus)

Hardware List (N709P288891K)

Liste du matériel

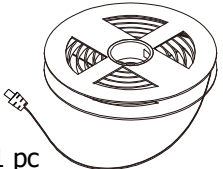
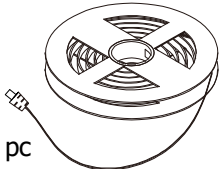
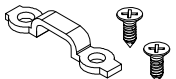
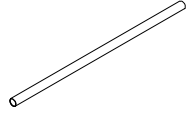
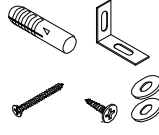

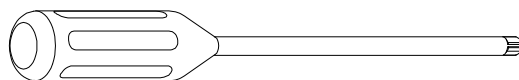
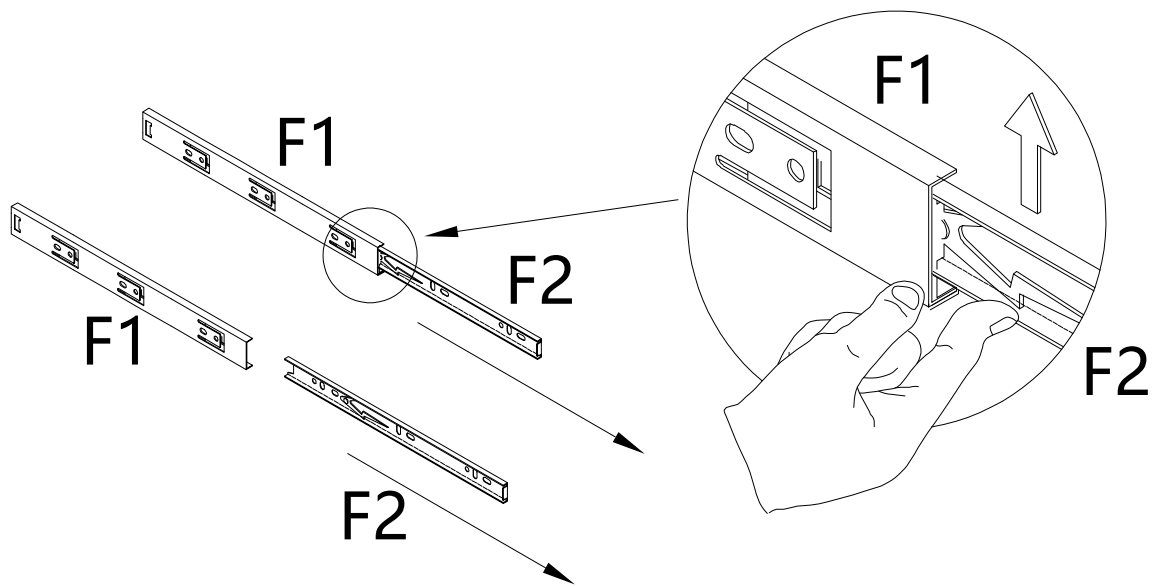



<p>P</p>  <p>1185mm LED-1 pc LED 1185 mm</p>	<p>Q</p>  <p>775mm LED-1 pc LED 775 mm</p>	<p>R</p>  <p>LED Clip + CSK Screw 3.5x14mm-8 Set Clip LED + vis CSK</p>
<p>S</p>  <p>Pipe Aluminium 19x1x395mm-1 PC Tuyau en aluminium</p>	<p>T</p>  <p>Ameriwood anti tipping-2 set Ameriwood anti-basculément</p>	



Assembly Tools Required (Not included)
Outils d'assemblage requis (non inclus)



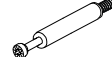



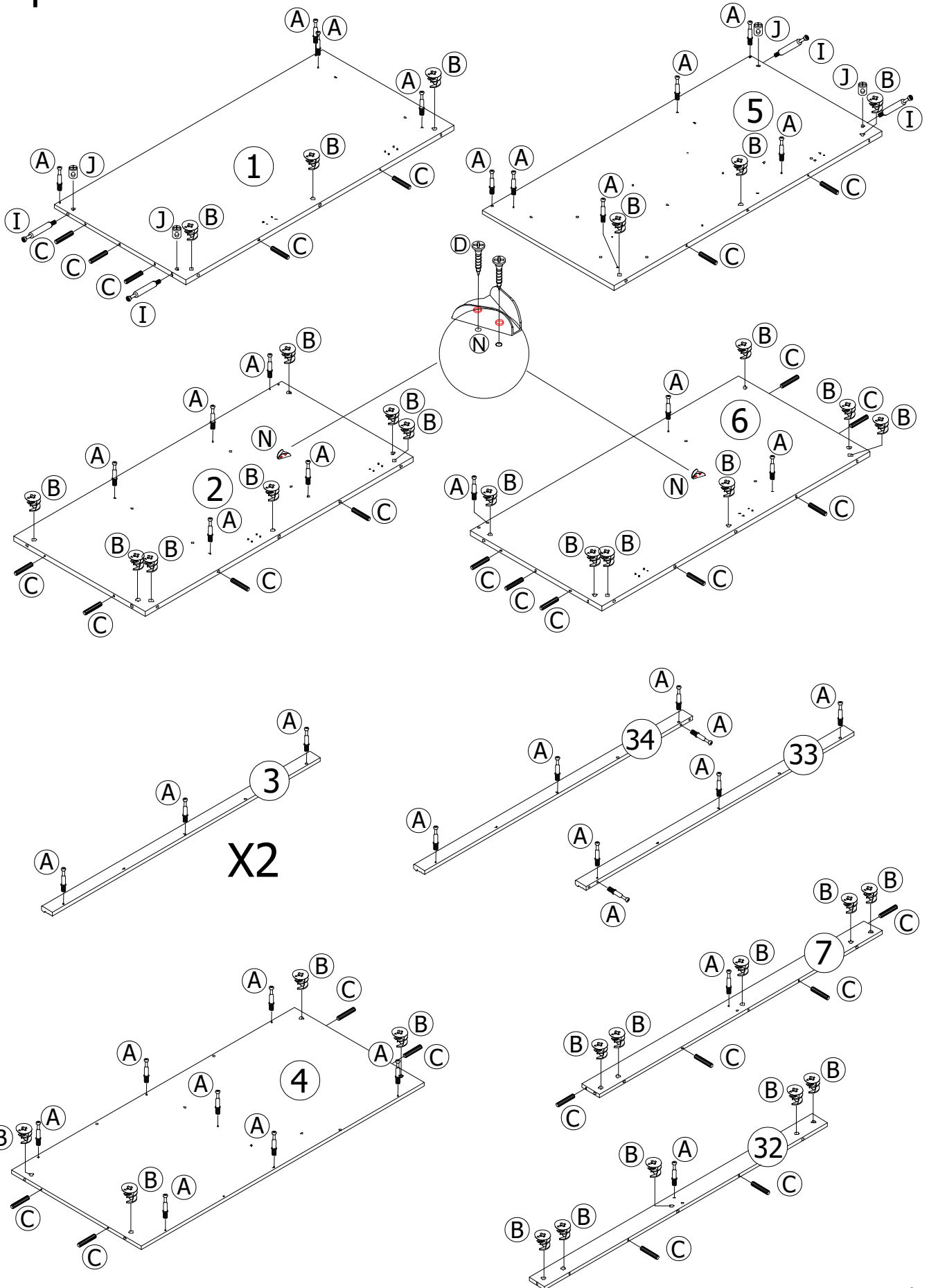



Step 1 :

Étape 1:

A	B	C	D	I	J	N
						
41pcs	34pcs	28pcs	4pcs	4pcs	4pcs	2pcs



Step 2 : Étape 2:

A 	B 	C 	D 	I 	J 	N 	P 	
18pcs	31pcs	31pcs	4pcs	2pcs	2pcs	2pcs	1pc	
Q 	R 							
1pc	8 set							

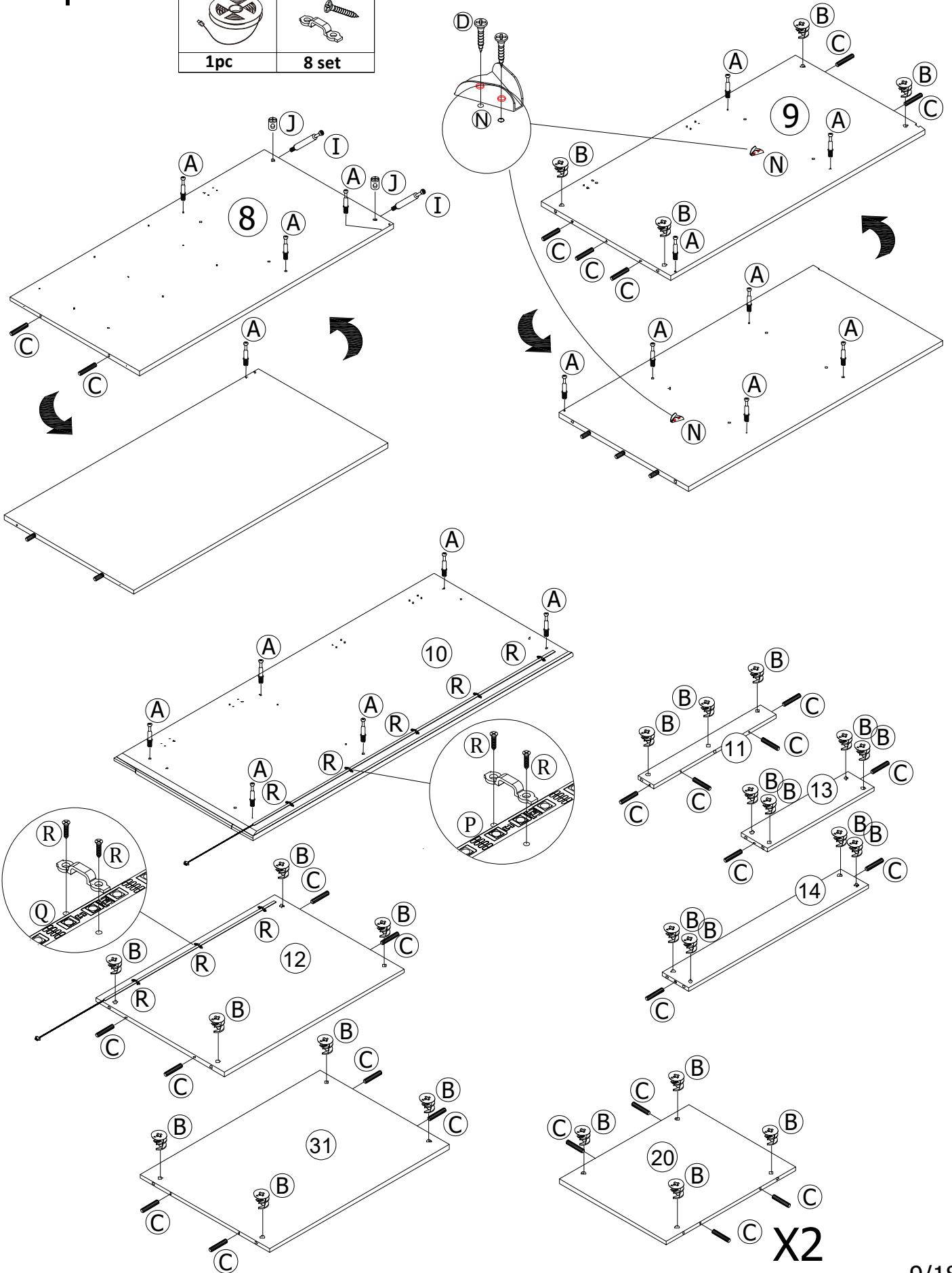

Step 3 :
Étape 3:

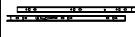
D	F
	
18pcs	3set

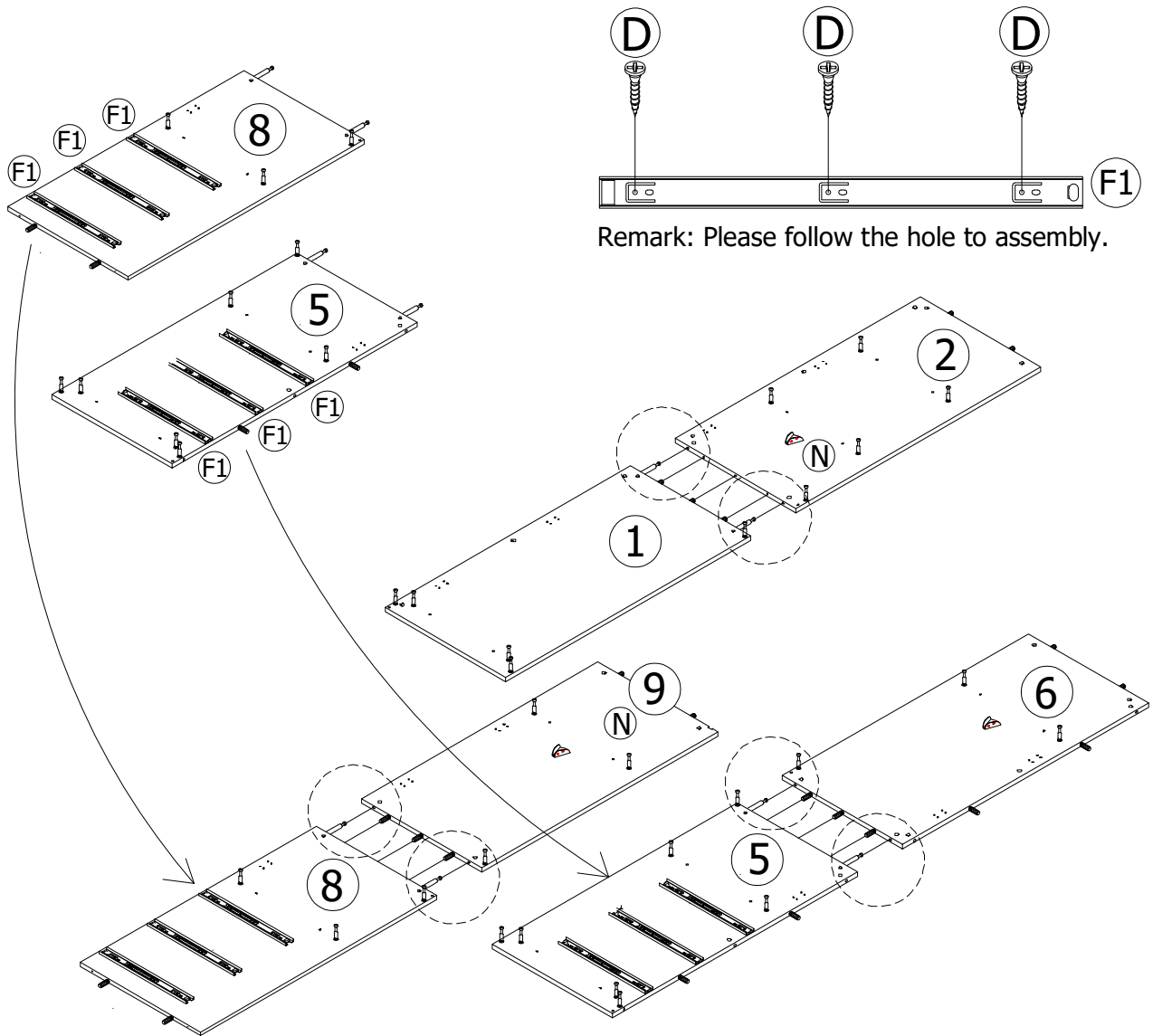

Step 4 :
Étape 4:

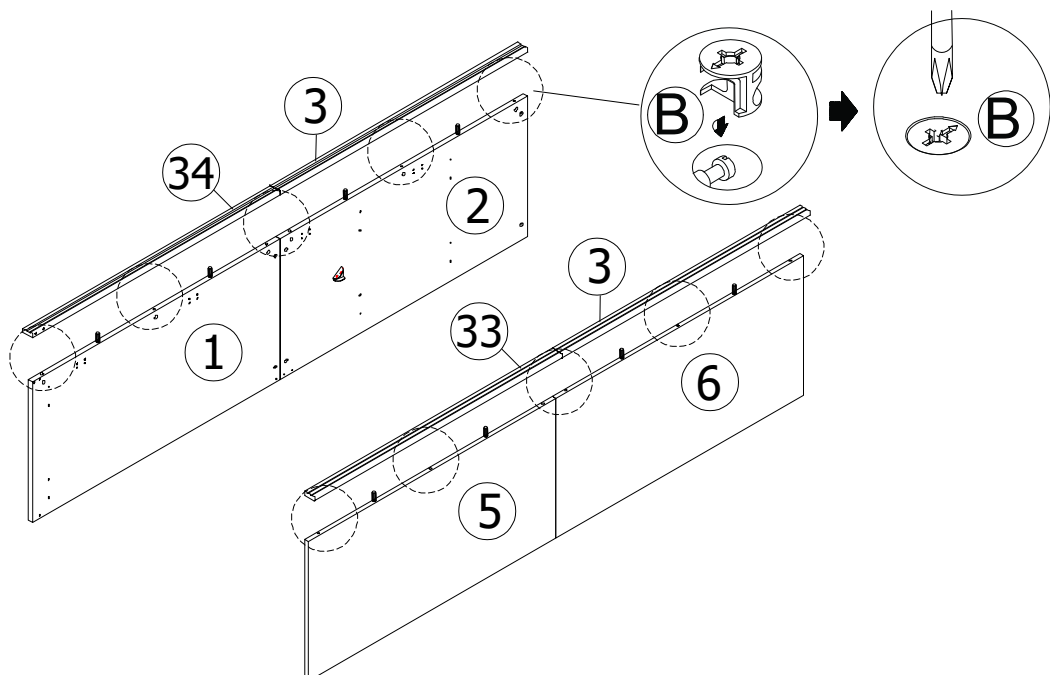

Step 5 :
Étape 5:

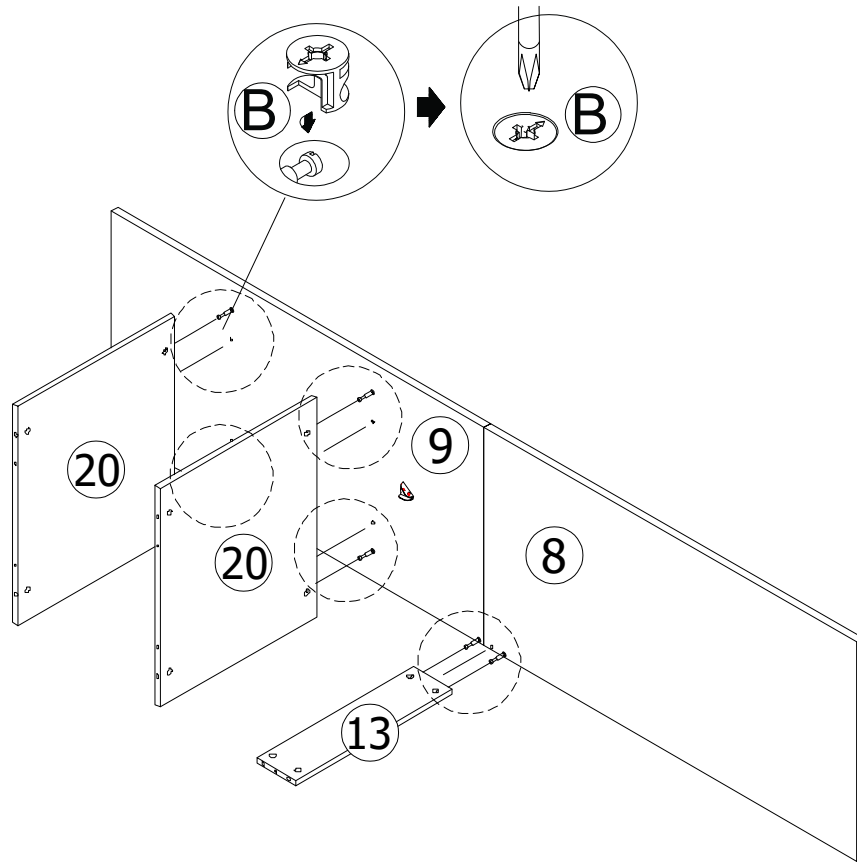

Step 6 :
Étape 6:

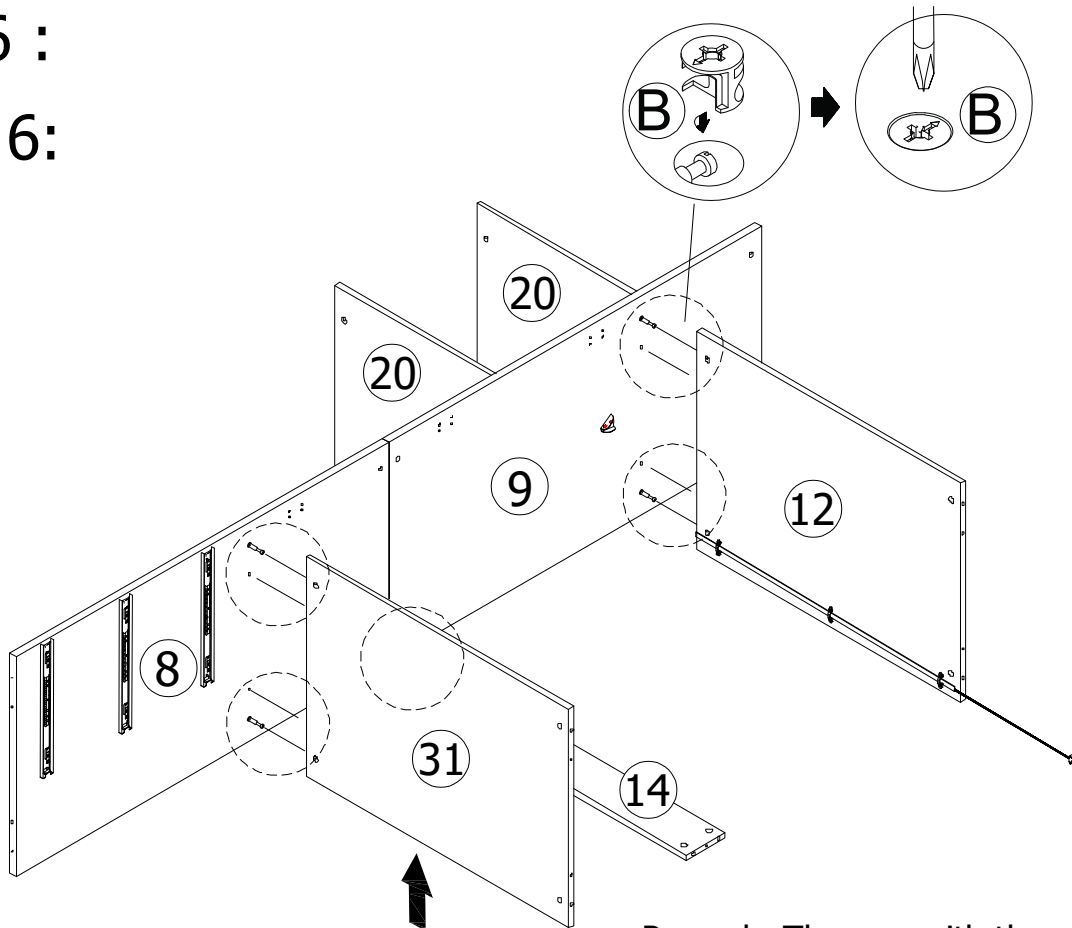

Remark: The one with the marking
is at the back

Step 7 :

Étape 7:

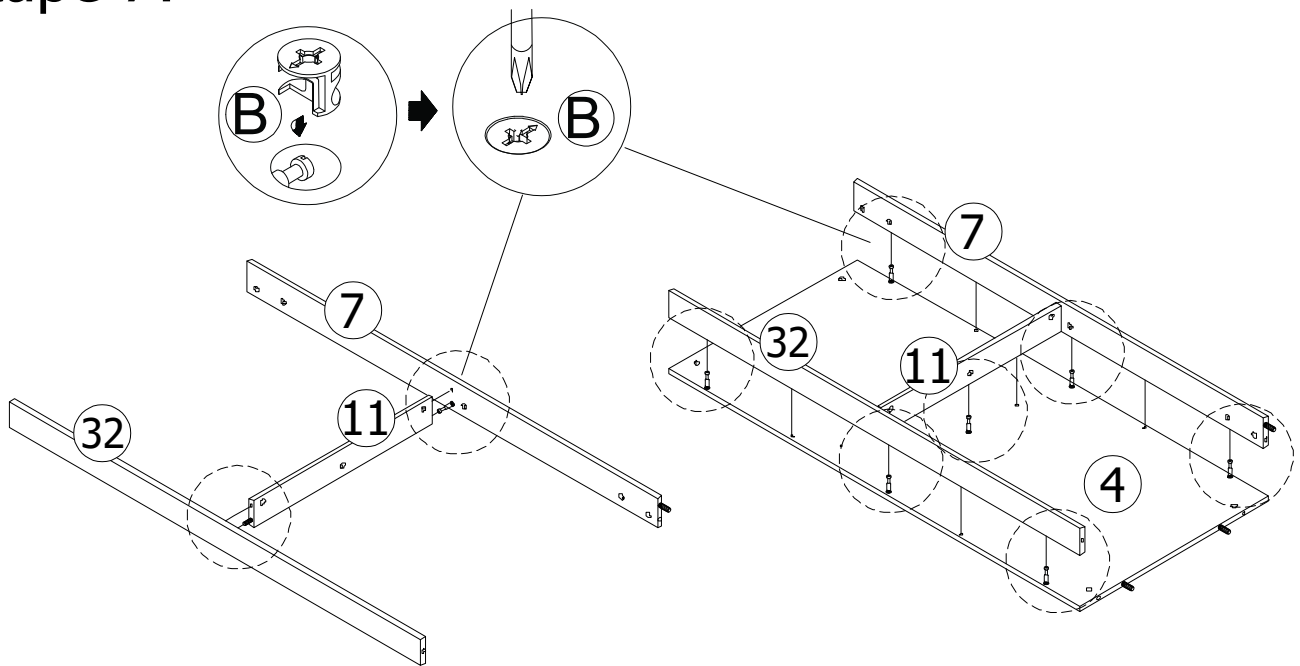

STEP 7.1

STEP 7.2

Step 8 :

Étape 8:

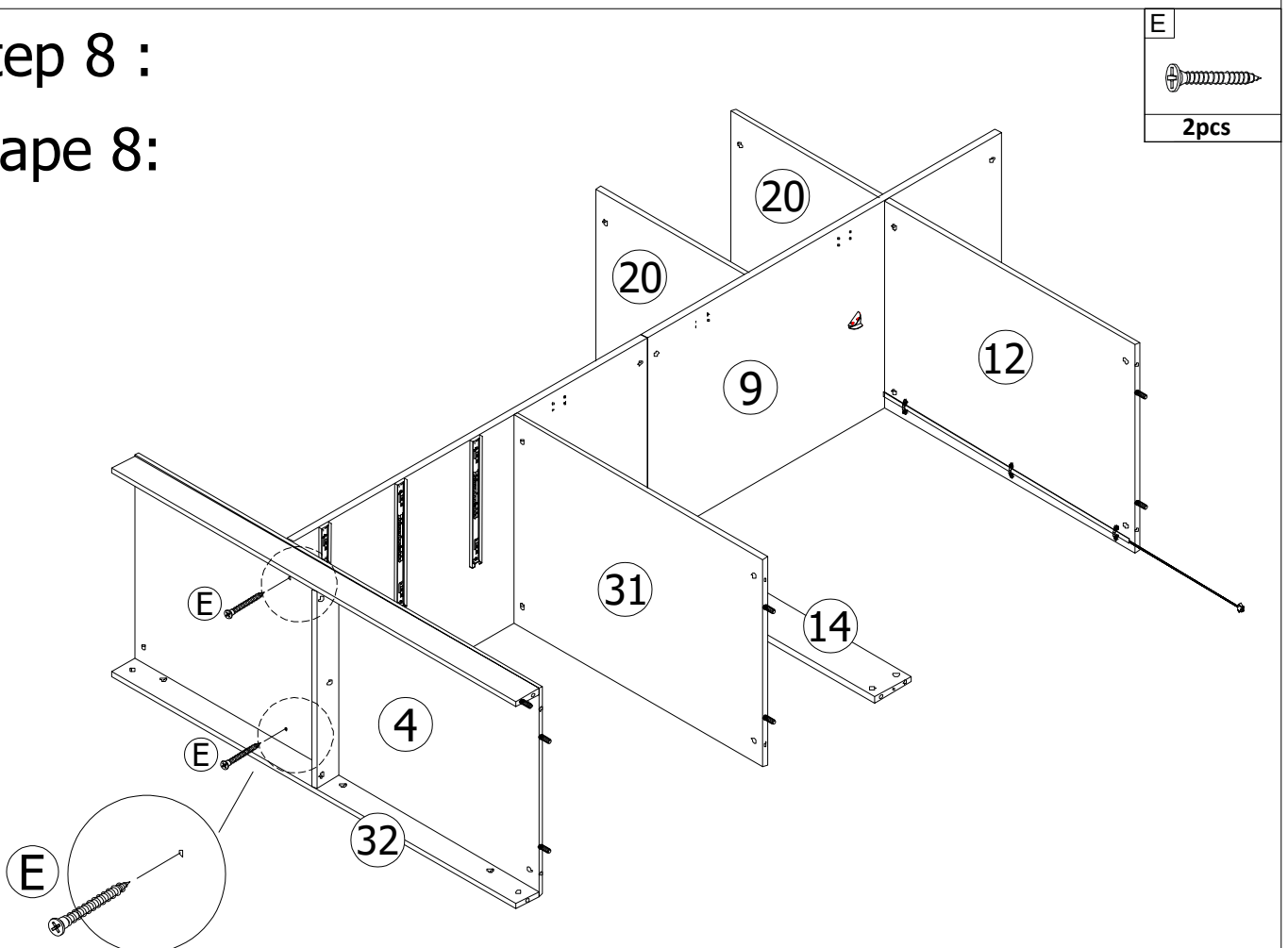

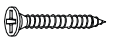
E

2pcs

Step 9 :

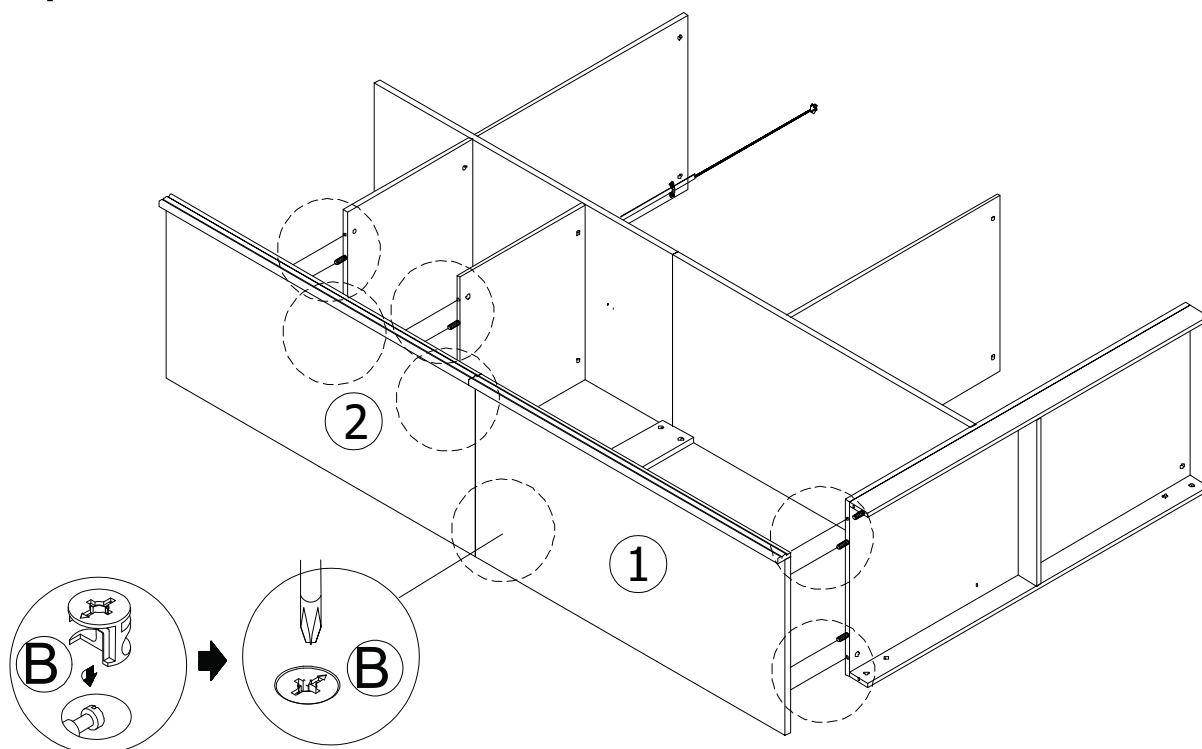
Étape 9:



Step 10 :

Étape 10:

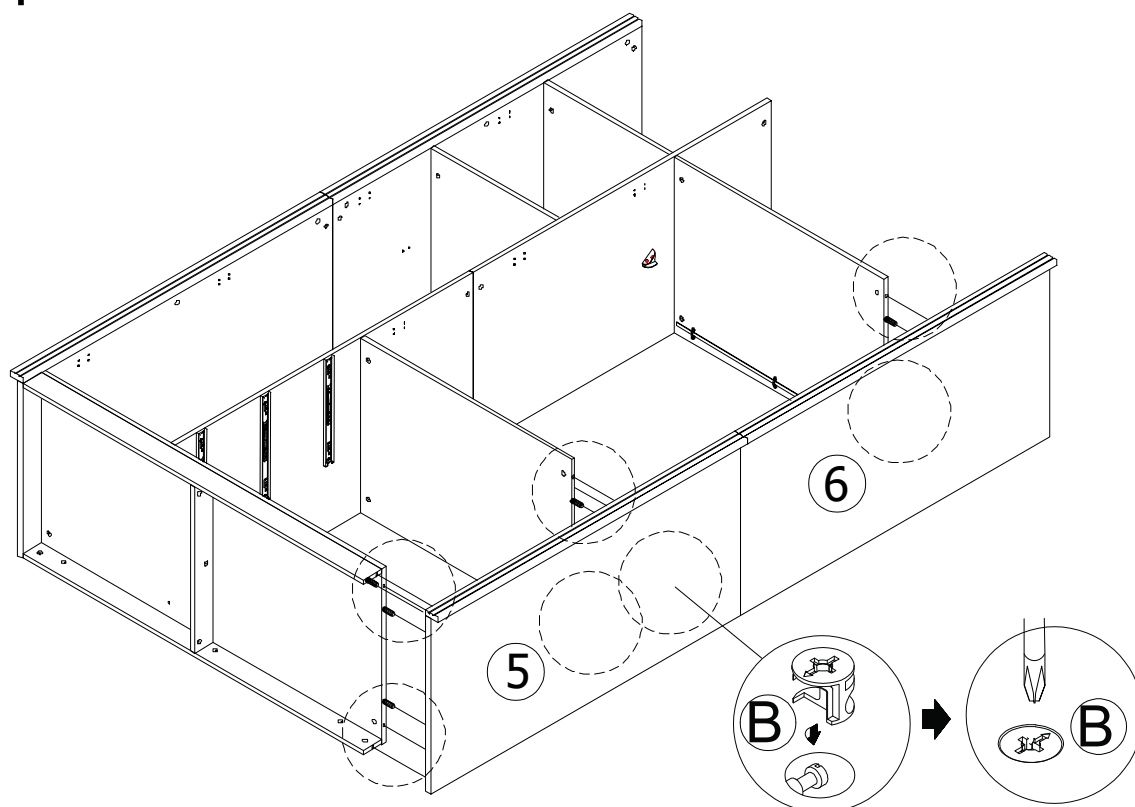

Step 11 :

Étape 11:

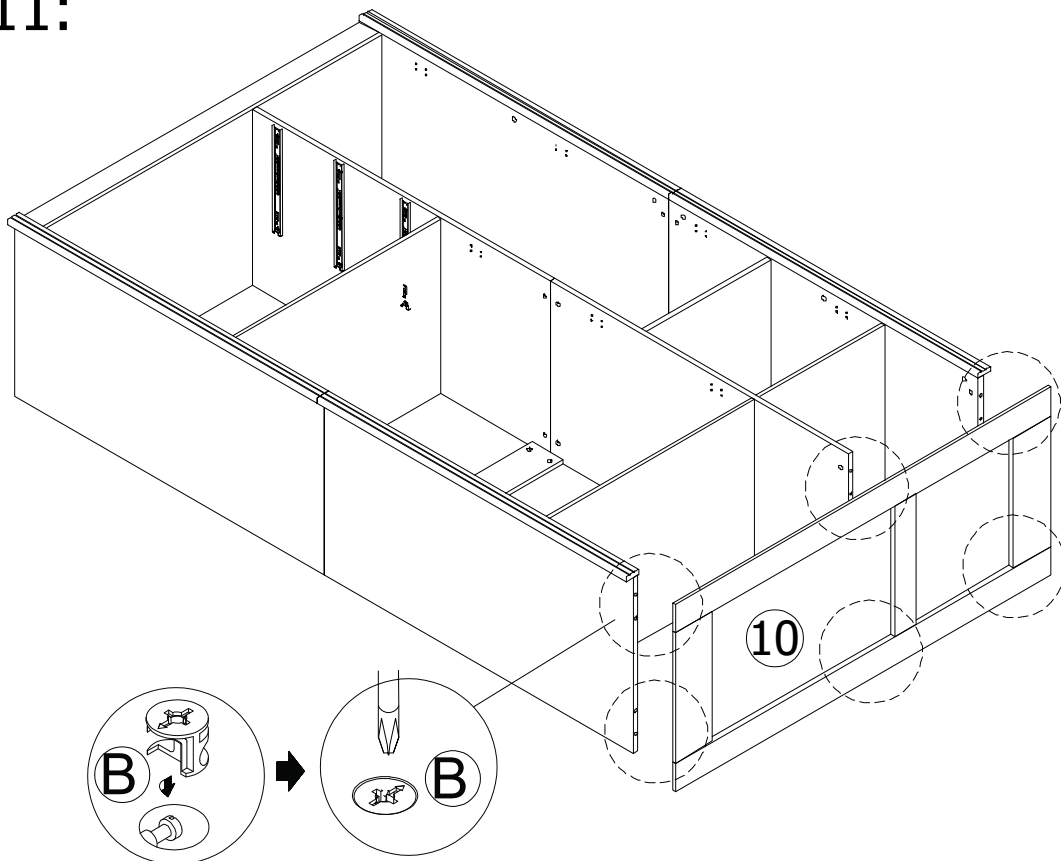

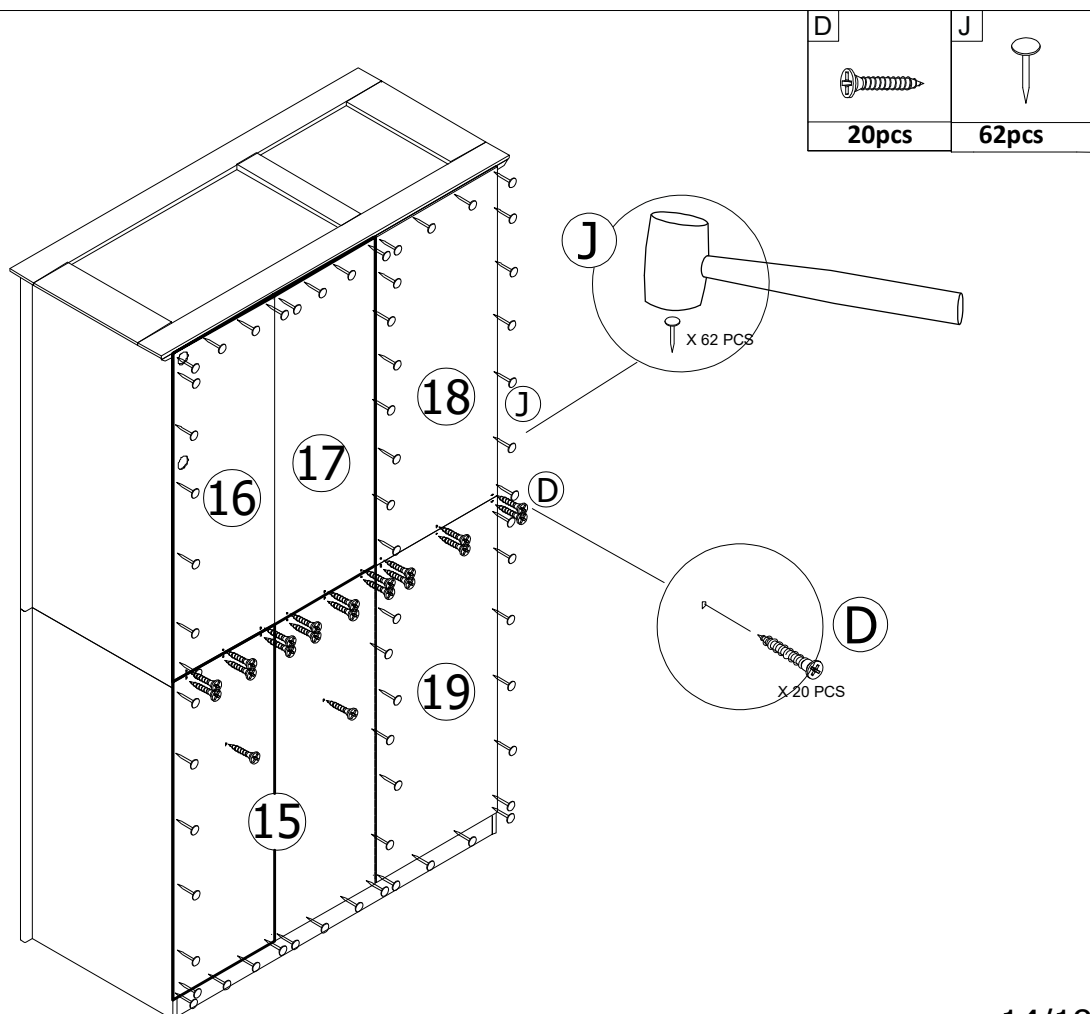

Step 12 :

Étape 12:



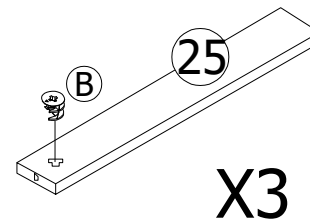
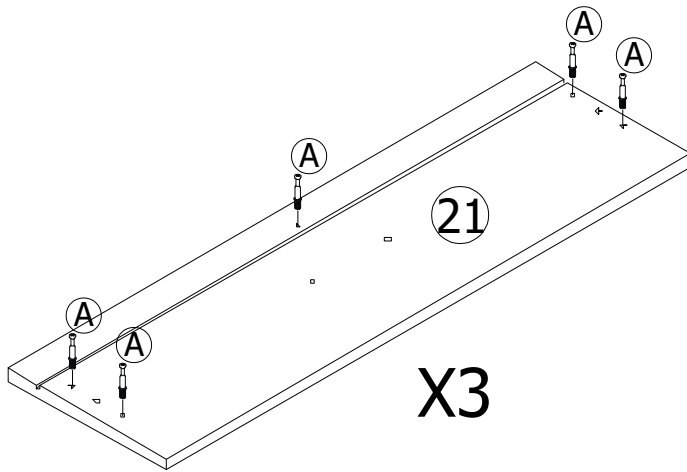

Step 13 :
Étape 13:

A		B	
	15pcs		3pcs

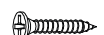
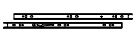

Step 14 :
Étape 14:

B		C		D		F	
	12pcs		6pcs		18pcs		3set

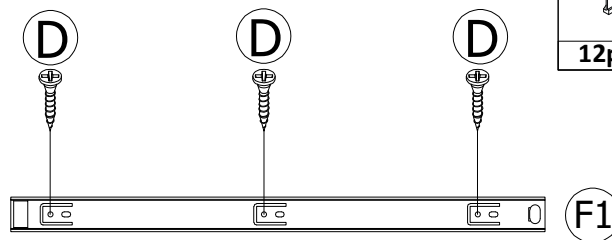

Remark: Please follow the hole to assembly.

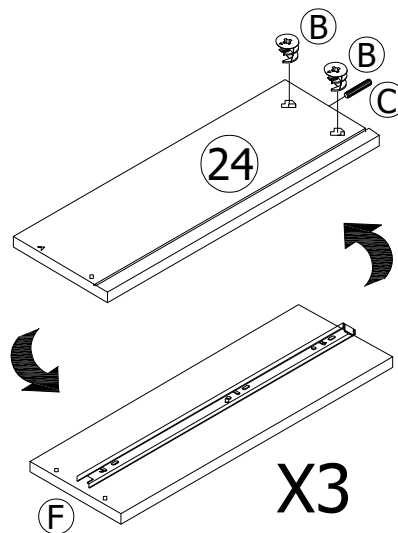
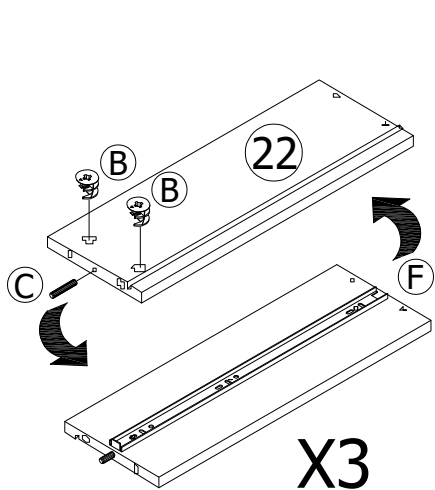

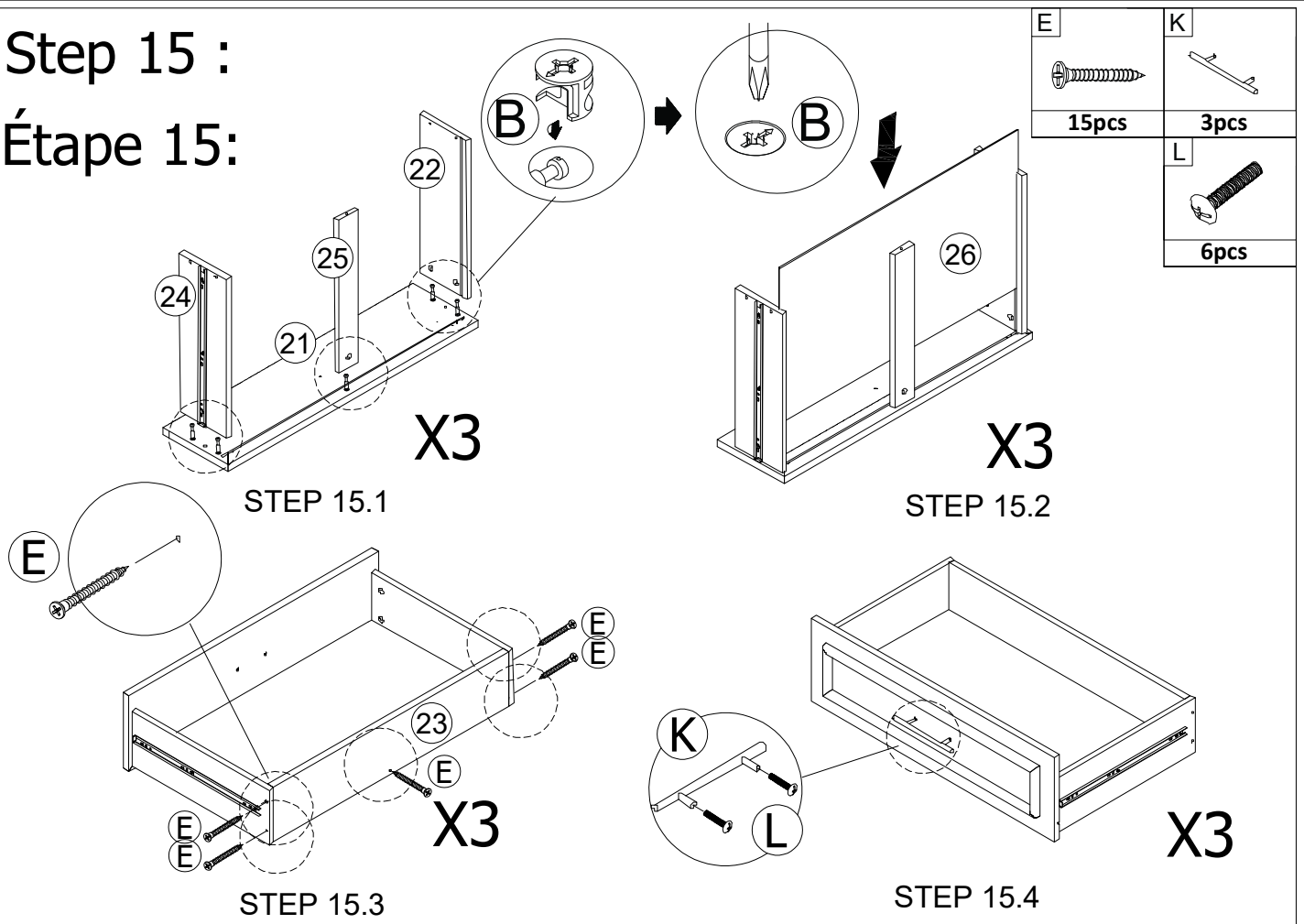

Step 15 :
Étape 15:

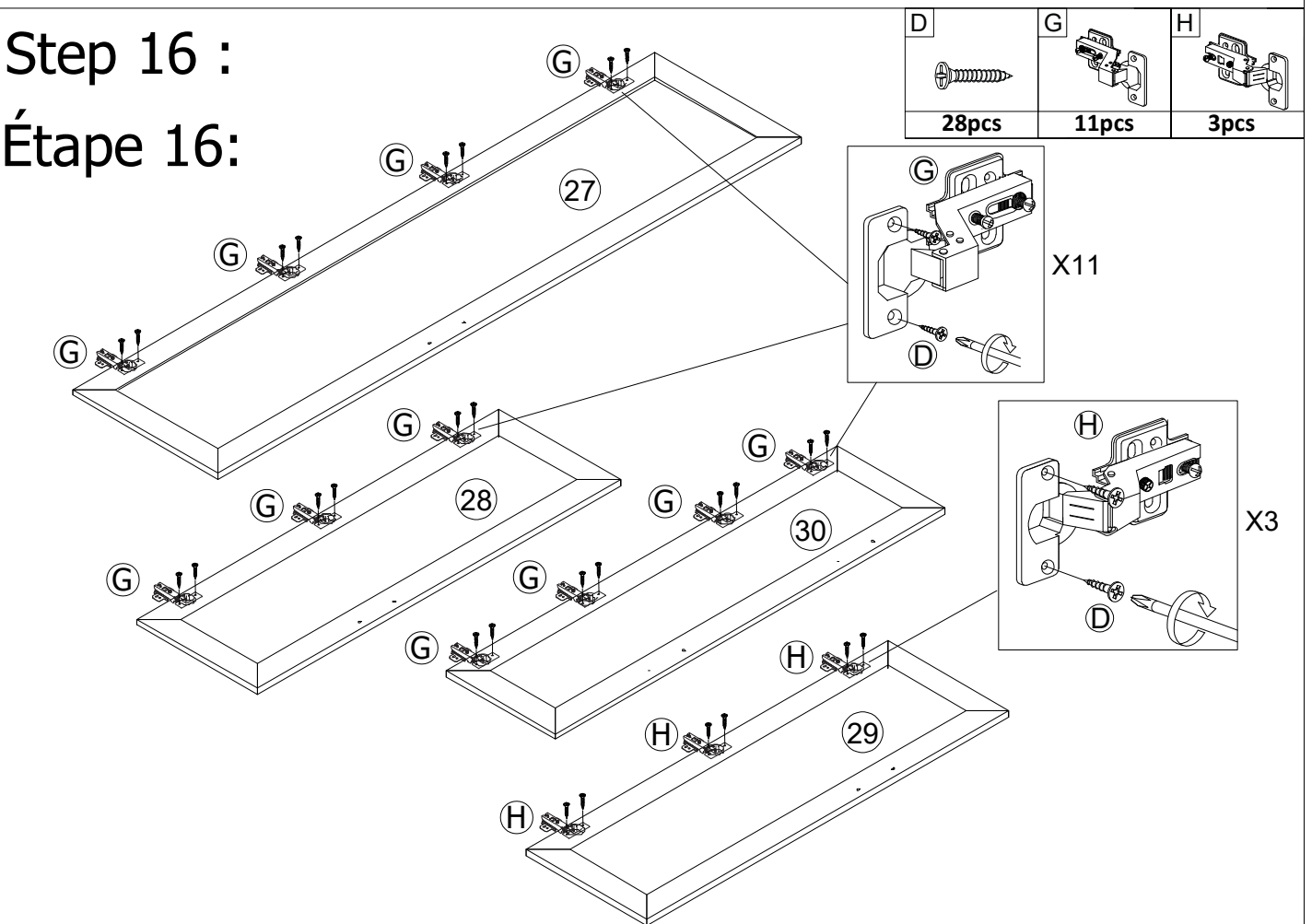

Step 16 :
Étape 16:



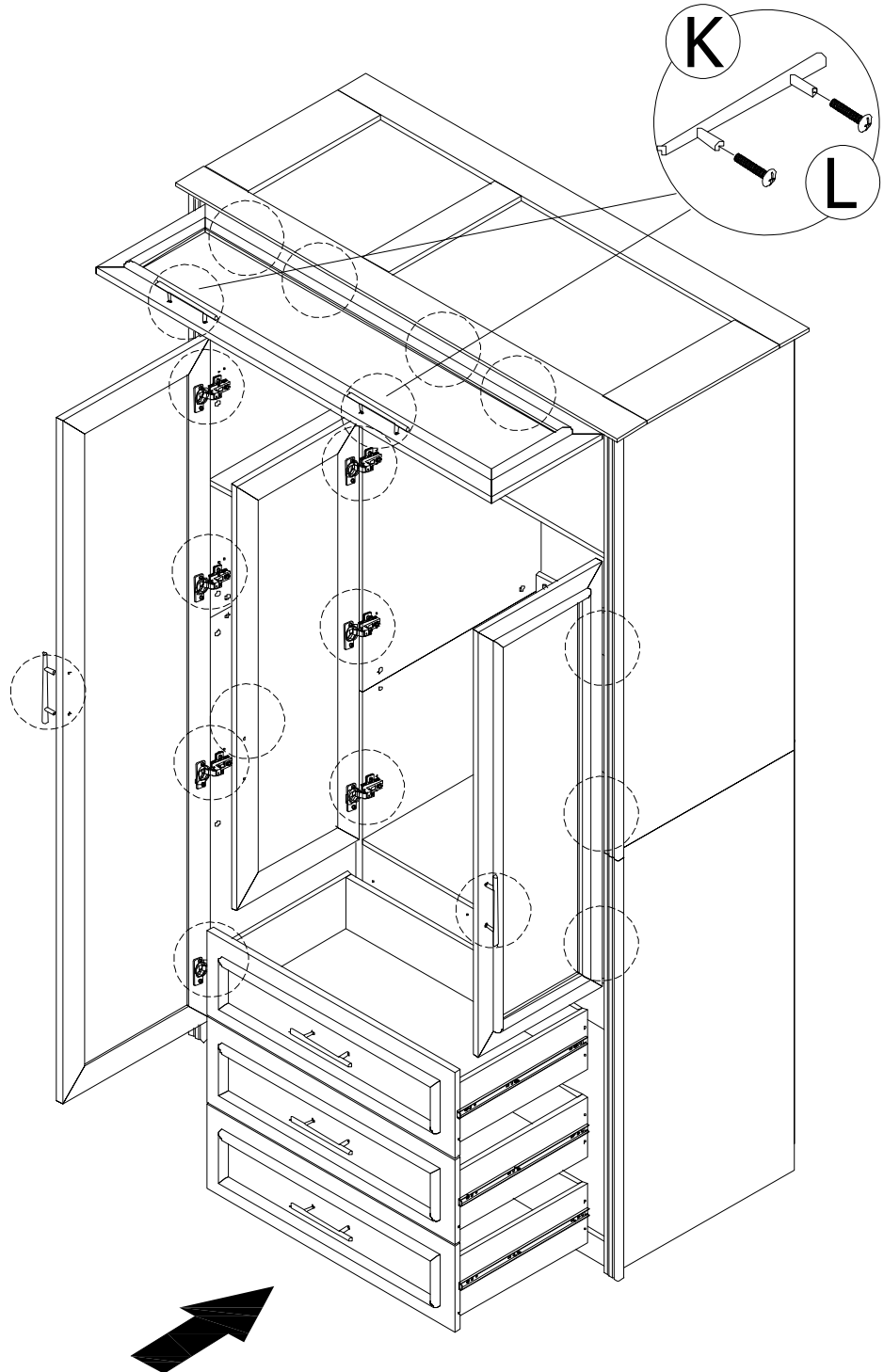
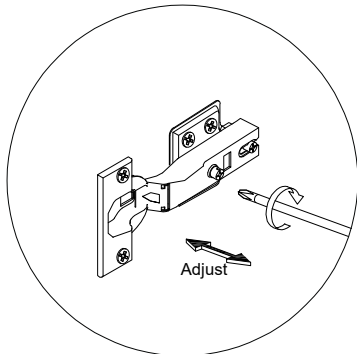
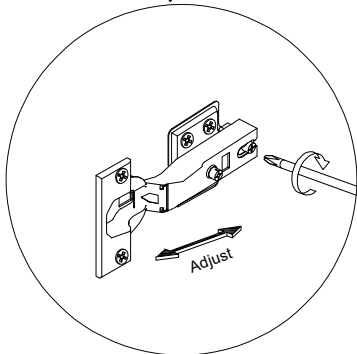
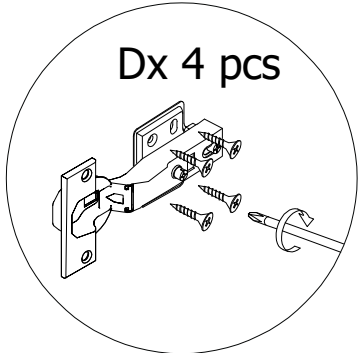

Step 17 : Étape 17:

D	K	L
		
56pcs	5pcs	10pcs



Step 18 :

Étape 18:

O	S
	
1pc	1pc

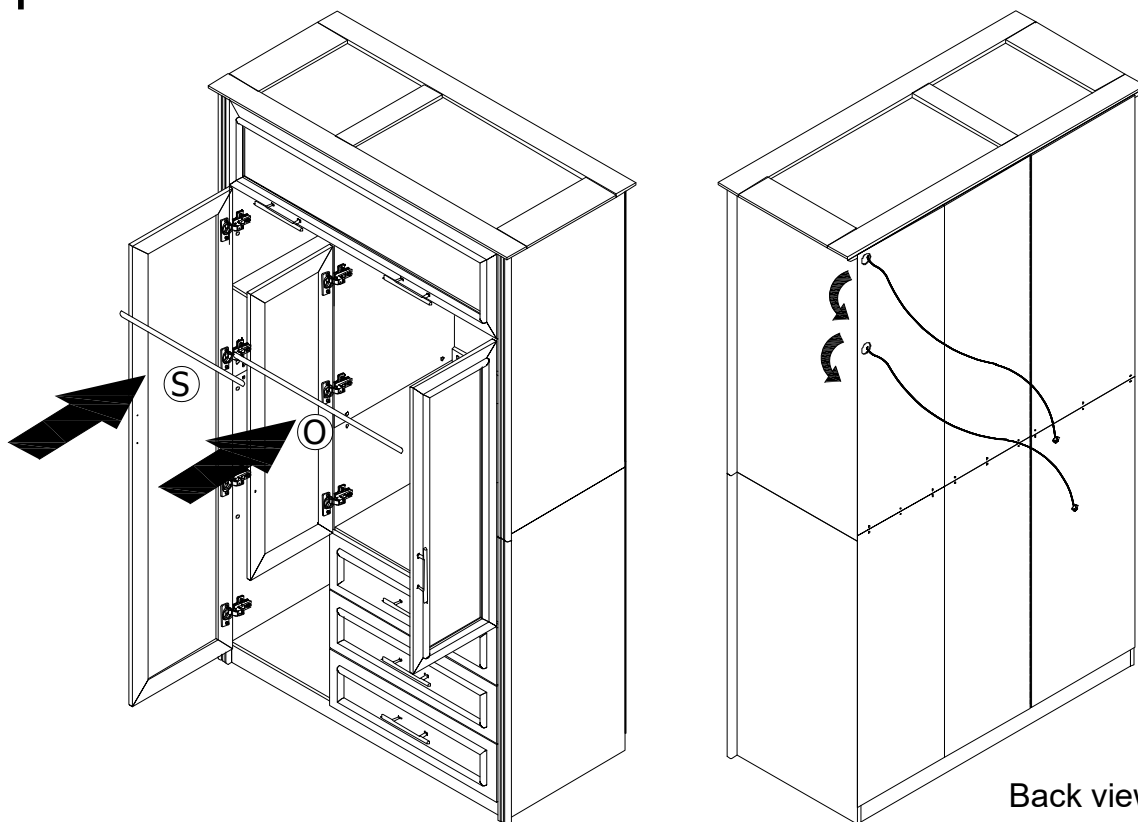

Back view

Step 19 :

Étape 19:

T

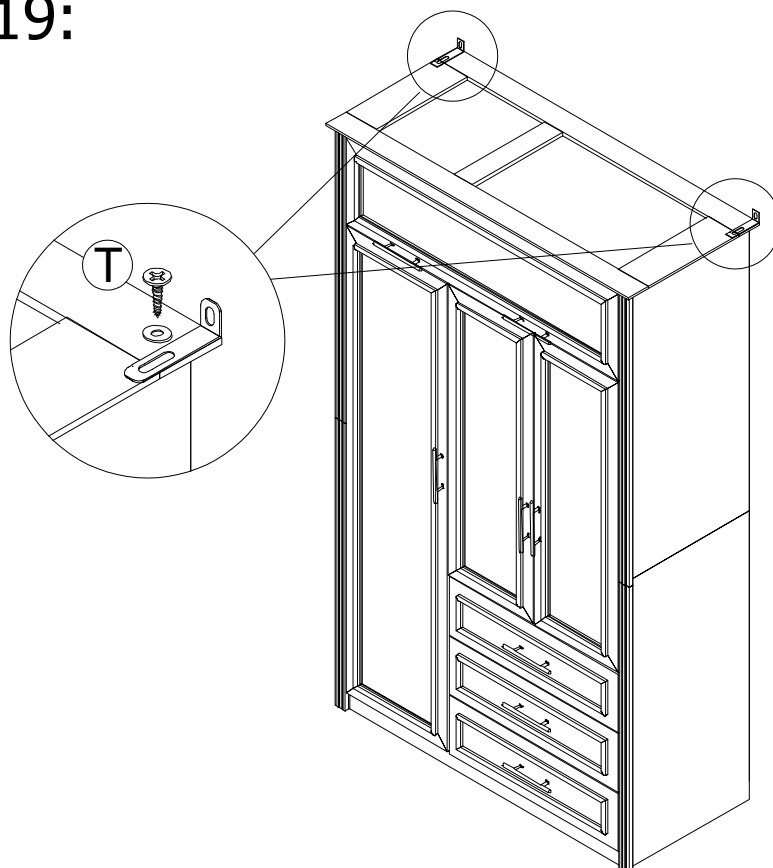
2set





FURNITURE ANTI-TIPPING INSTALLATION



This anti-tipping must be attached to a wall stud using screw enclosed:

1. After assembling the unit, place it against the wall where it will be permanently positioned.
2. Place the bracket on top of the wardrobe as shown in the diagram.
3. Use a pencil to mark through the screw hole in the bracket, where the bracket has to be attached to the wall.
4. Move the cabinet away from the wall and secure the bracket to the wall at the marked position using a wall plug that suited to your wall surface.
5. With the wall brackets in position, move the cabinet back to the wall.
6. Then using the screw supplied, secure the horizontal arm of the brackets to the top of the wardrobe.

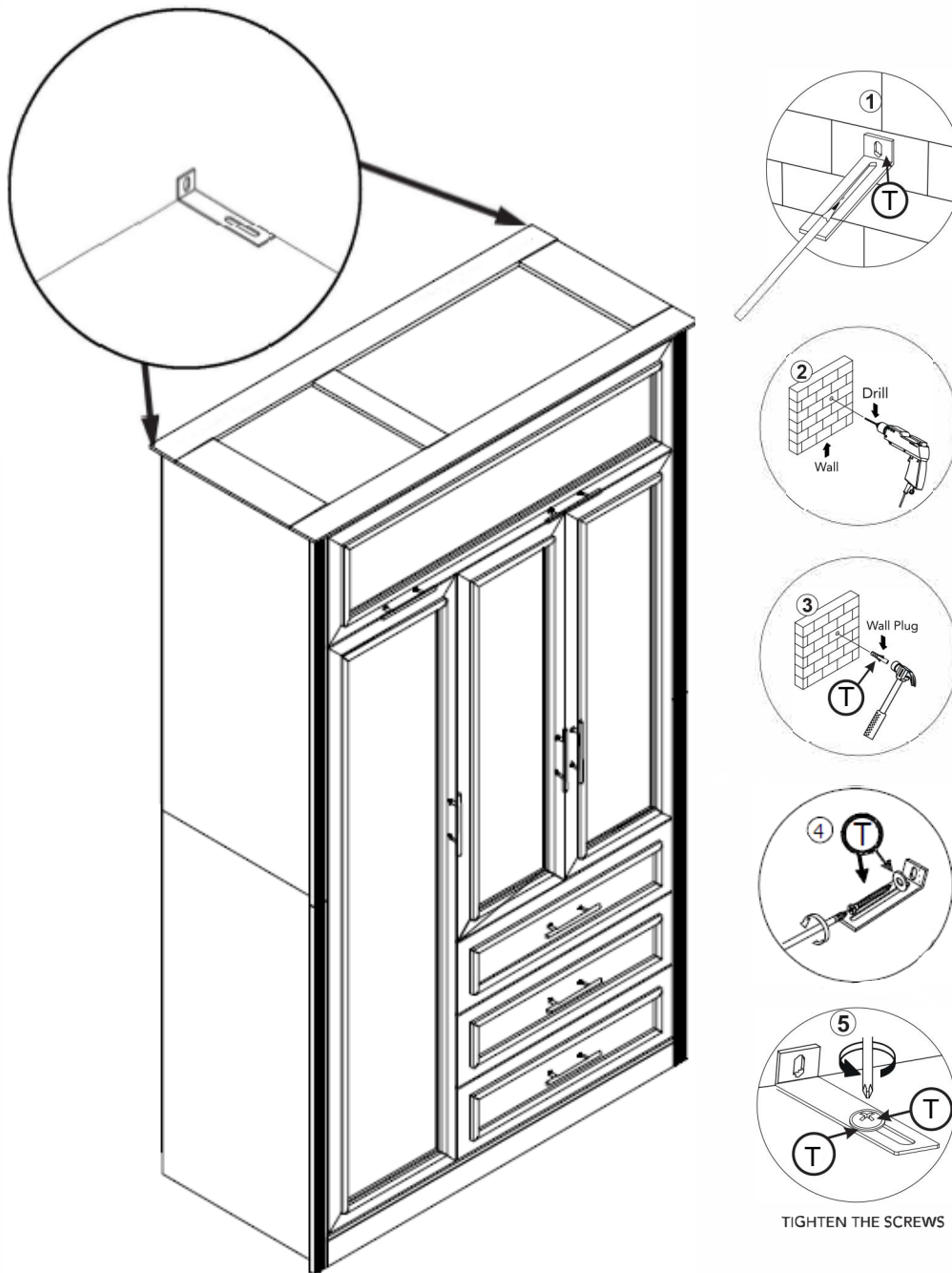

TIGHTEN THE SCREWS

Manufacturer: T.A. FURNITURE & PROJECTS SDN BHD
 Address: Lot 267, Kawasan Perindustrian Bukit Pasir,
 Mukim Sungai Raya, 84300
 Bukit Pasir, Muar,
 Johor Darul Takzim, Malaysia.

Manufacturing Date: October 2024

T		T		T		T	
	2PCS		2PCS		2PCS		4PCS
							2PCS

Meets ASTM F3096-23