

ASSEMBLY INSTRUCTION

ITEM NO: MDO-505



** Please kindly check inside the seat for some parts.*

BOX 1: MDO-G007-C

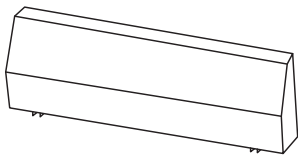

A = 1 PC

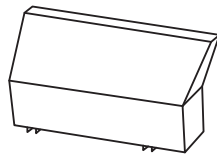

B = 1 PC

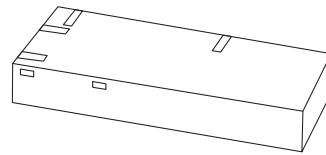

C = 1 PC

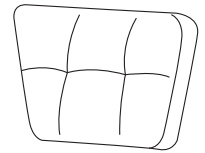

H = 1 PC

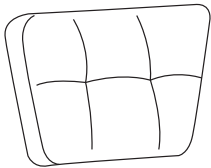

I = 1 PC

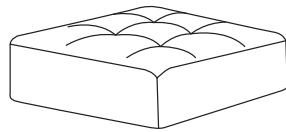

P = 1 PC



M = 1 PC



N = 4 PCS

BOX 2: MDO-G007-S

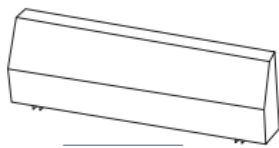

D=1PC

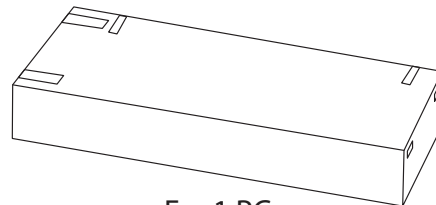

E = 1 PC

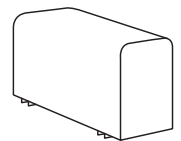

F = 1 PC

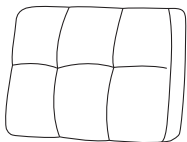

J=2PCS

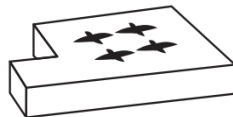

O=1PC

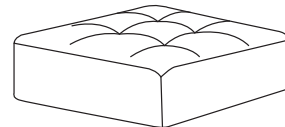

K = 2 PCS



N = 4 PCS

BOX 3: MDO-G007-O



J=2PCS

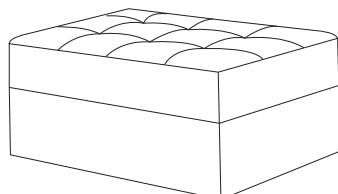

G = 1 PC



N = 4 PCS

STEP 1 - ATTACH THE LEGS BY TWISTING THE LES ONTO THE CORNERS OF THE SOFA BY LOCATING THE HOLES AND ALIGNING THEM.

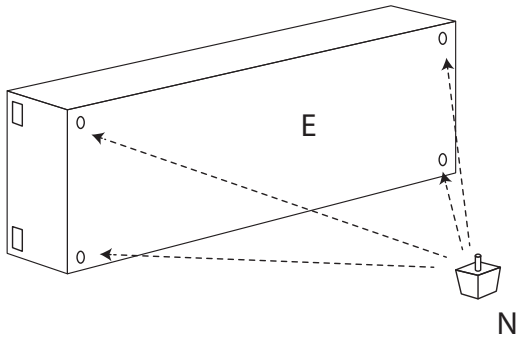

STEP 2 - ATTACH THE LEGS BY TWISTING THE LES ONTO THE CORNERS OF THE CHAISE BY LOCATING THE HOLES AND ALIGNING THEM.

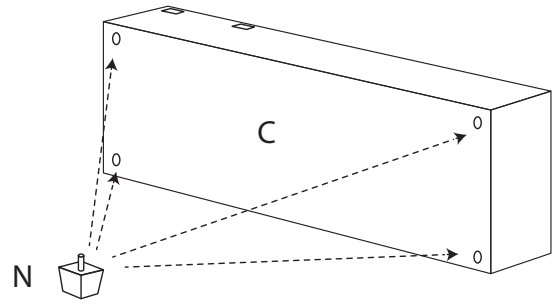

STEP 3: ALIGN THE HINGES ON THE SIDE OF THE SOFA AND CHAISE AND LIFT UP THE SIDE WHERE THE HINGES GO DOWN, MAKING THEM SLOT TOGETHER.

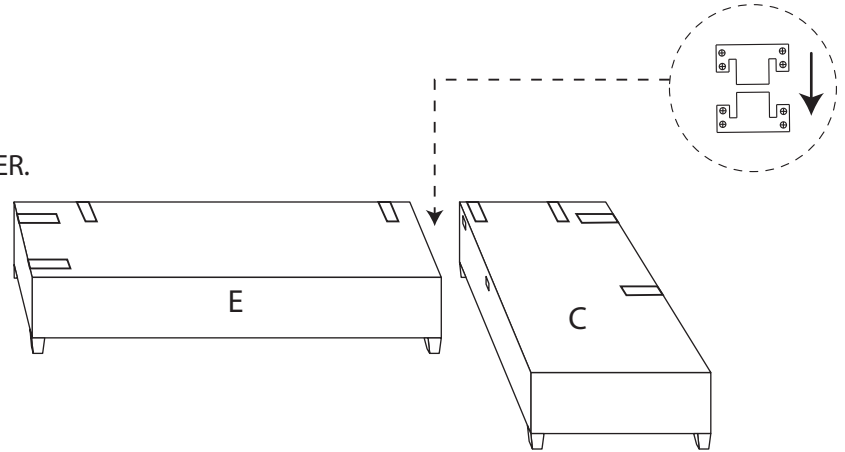

STEP 4 - ALIGN THE METAL SLOTS BENEATH THE ARM ONTO THE TOP OF THE SOFA AND SLOT THEM IN.

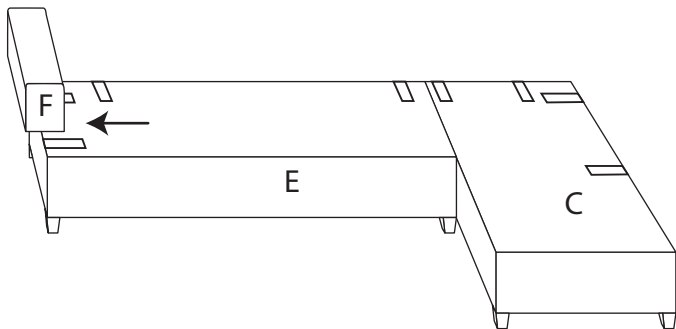

STEP 5 - ALIGN THE METAL SLOTS BENEATH THE BACK REST ONTO THE TOP OF THE SOFA AND SLOT THEM IN.

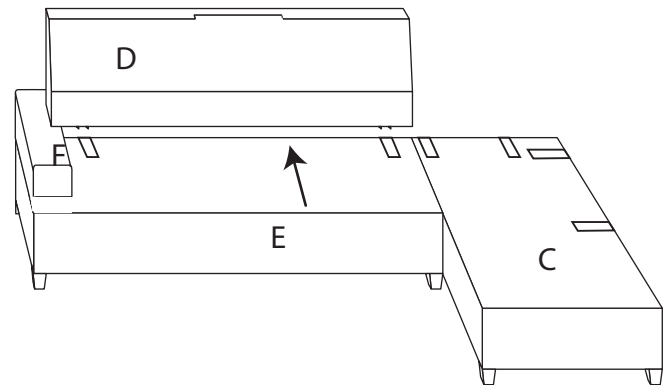

STEP 6 - ALIGN THE METAL SLOTS BENEATH THE BACK REST ONTO THE TOP OF THE CHAISE AND SLOT THEM IN.

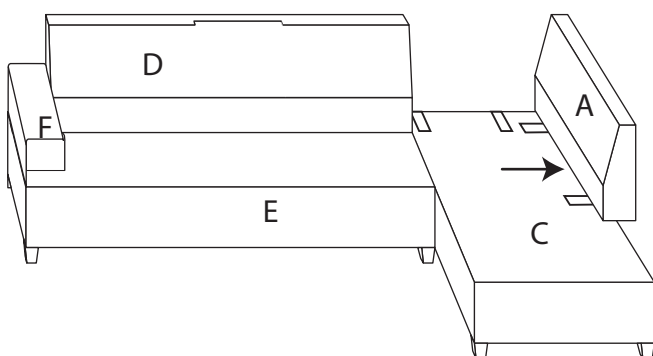

STEP 7 - ALIGN THE METAL SLOTS BENEATH THE BACK REST ONTO THE TOP OF THE CHAISE AND SLOT THEM IN.

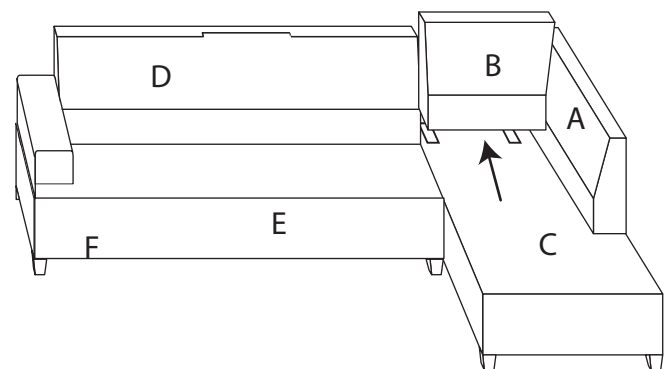

STEP 8 - ATTACH THE LEGS BY TWISTING THE LEGS ONTO THE CORNERS OF THE SOFA BY LOCATING THE HOLES AND ALIGNING THEM.

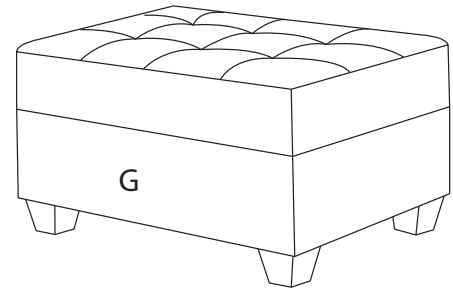
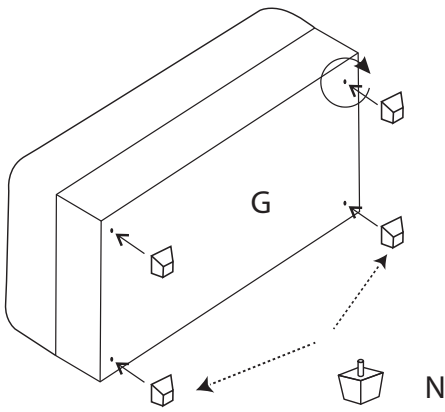

STEP 9: INSTALL THE CUP HOLDER BY INSERTING THREADED RODS INTO THE BACK WITH HEXAGON WRENCH AT TWO SIDES.

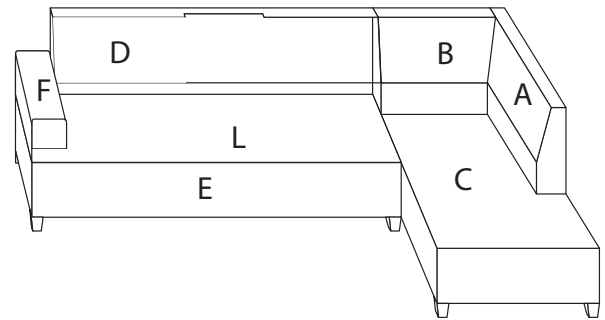

STEP 10: ONCE COMPLETED, YOU MAY PLACE THE PILLOWS ONTO THE SECTIONAL AND YOUR SOFA SECTIONAL IS NOW COMPLETED.

