

## STEP 4

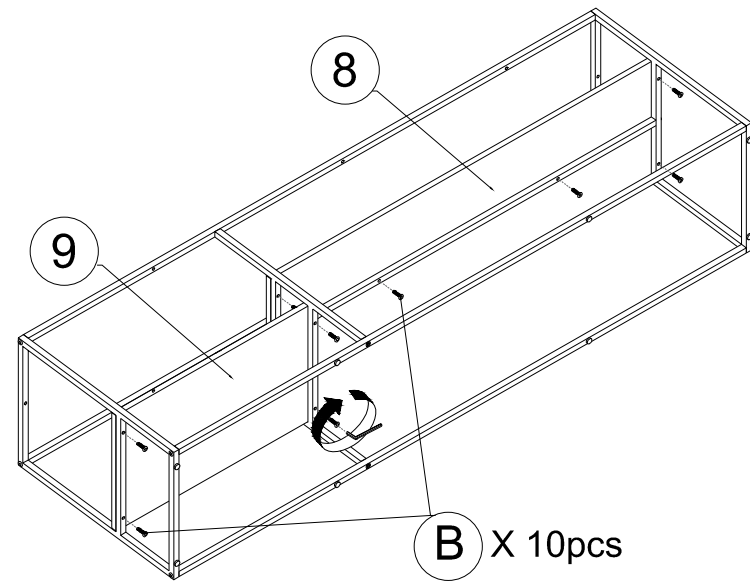

## STEP 5

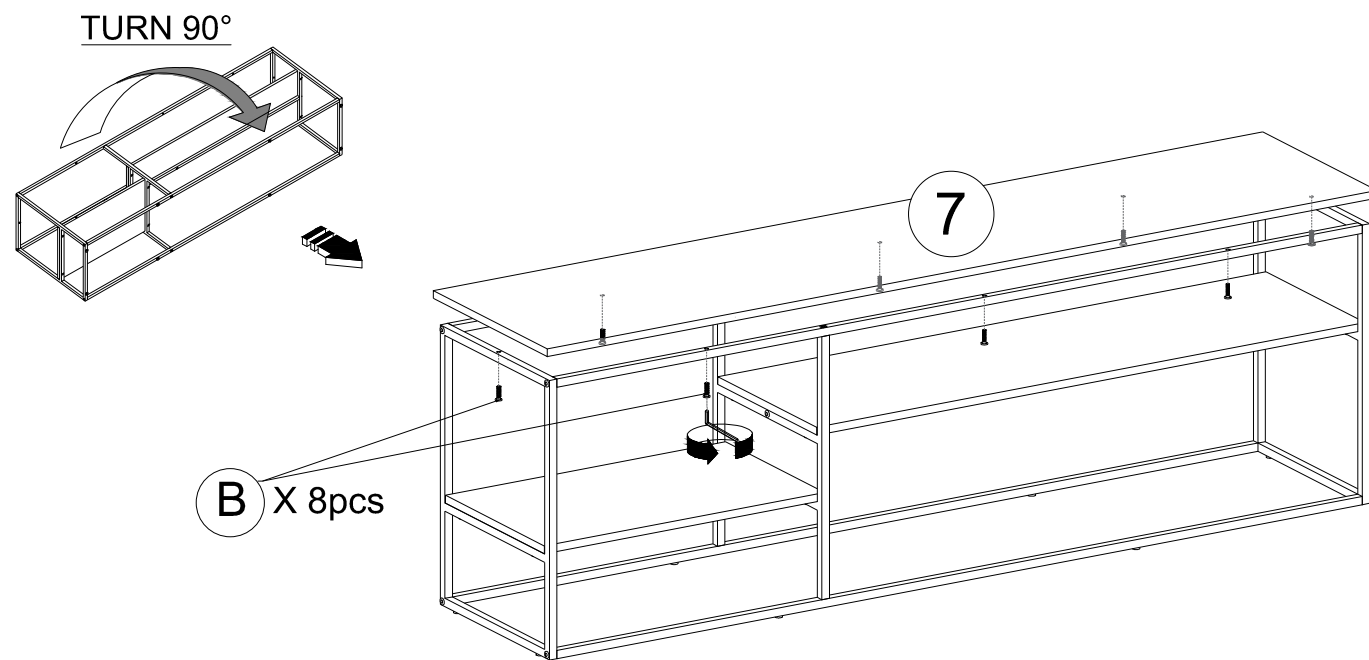

## Recommended Maximum Weight

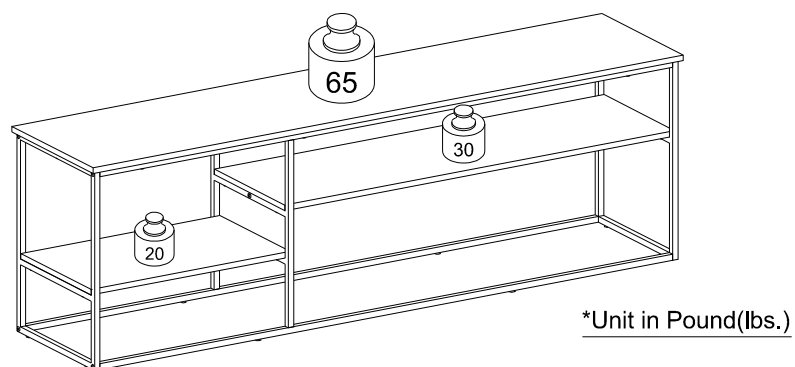

### **WARNING:**

>This unit has been designed to support the maximum loads shown. Exceeding these load limits could cause sagging, instability, product collapse, and/or serious injury.

>DO NOT allow children to climb on unit.

00:30

Approx. 30 minutes

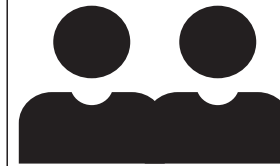

Recomm. 2 Persons

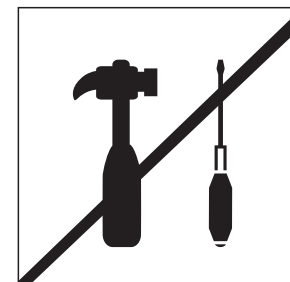



No Tools Required



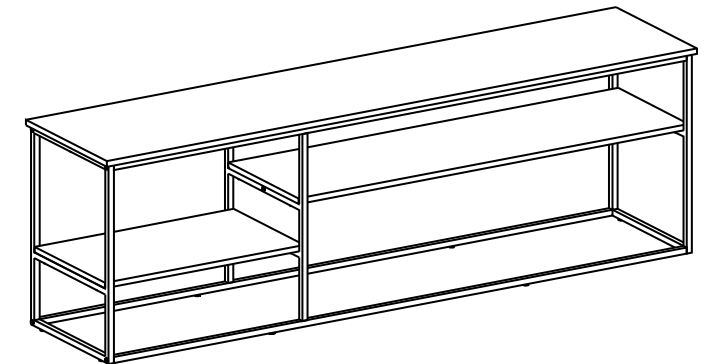





## Assembly Instruction

TV Stand for TV up to 65 Inch

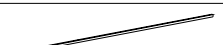

# HARDWARE & PARTS LIST

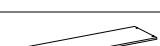
NO	HARDWARE LIST	QTY
A	LONG SCREW 	10pcs
B	SHORT SCREW 	18pcs
C	FLAT HEAD SCREW 	4pcs
D	ALLEN KEY 	1pc
E	RUBBER STUD 	8pcs

NO	PARTS LIST	QTY
1	METAL FRAME A 	1pc
2	METAL FRAME B 	1pc
3	METAL FRAME C 	1pc
4	UPPER RAIL 	2pcs
5	BOTTOM RAIL 	2pcs
6	CENTER RAIL 	1pc
7	TOP PANEL 	1pc
8	LARGE SHELF PANEL 	1pc
9	SMALL SHELF PANEL 	1pc

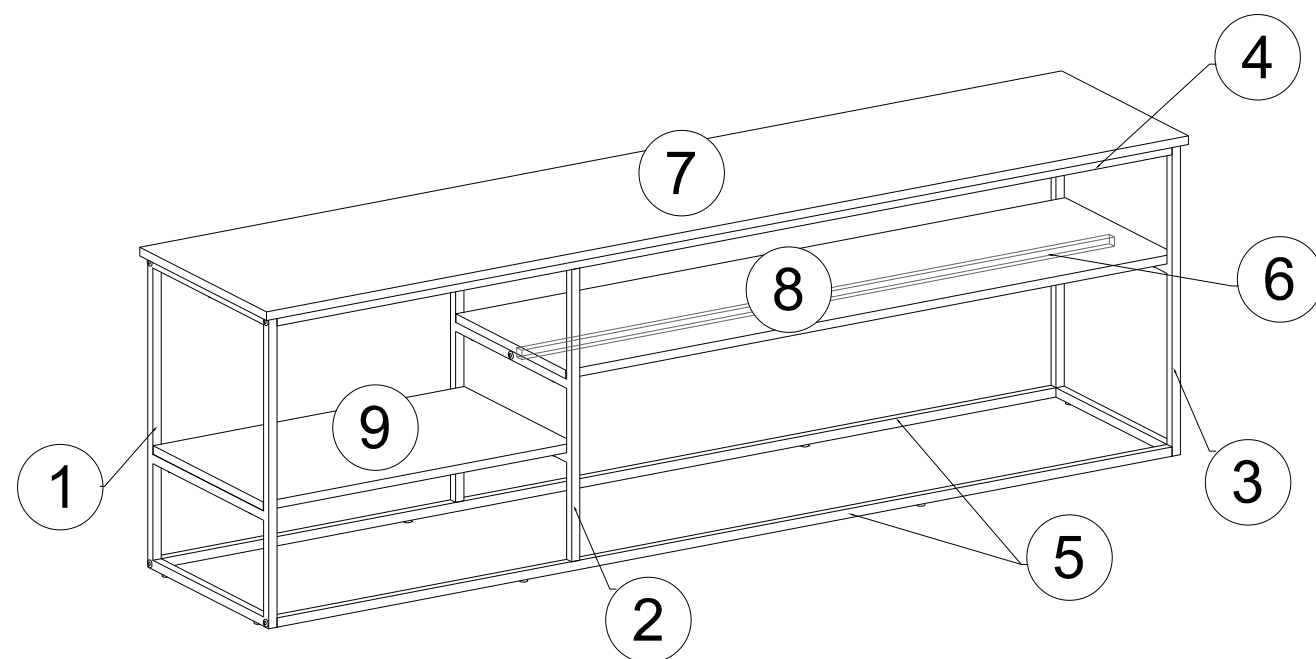

## USEFUL HINTS BEFORE YOU START:

1. Read each step carefully before assembling.
2. It is important that each step is performed in correct order to avoid difficulties.
3. Identify, sort and count the parts before assembly.
4. Assemble your furniture on packaging cardboard to prevent scratch or damage.
5. Clean the product with mild cleanser using soft damp cloth. Do not use harsh or abrasive cleanser.
6. Using incompatible hardware might cause damage to product.

# ASSEMBLY INSTRUCTIONS

BEFORE YOU BEGIN, PLEASE READ ASSEMBLY INSTRUCTION CAREFULLY, FOLLOW THEM STEP BY STEP.

REMINDER: Please do not fully tighten any screw until all of them are in right positions.

## STEP 1

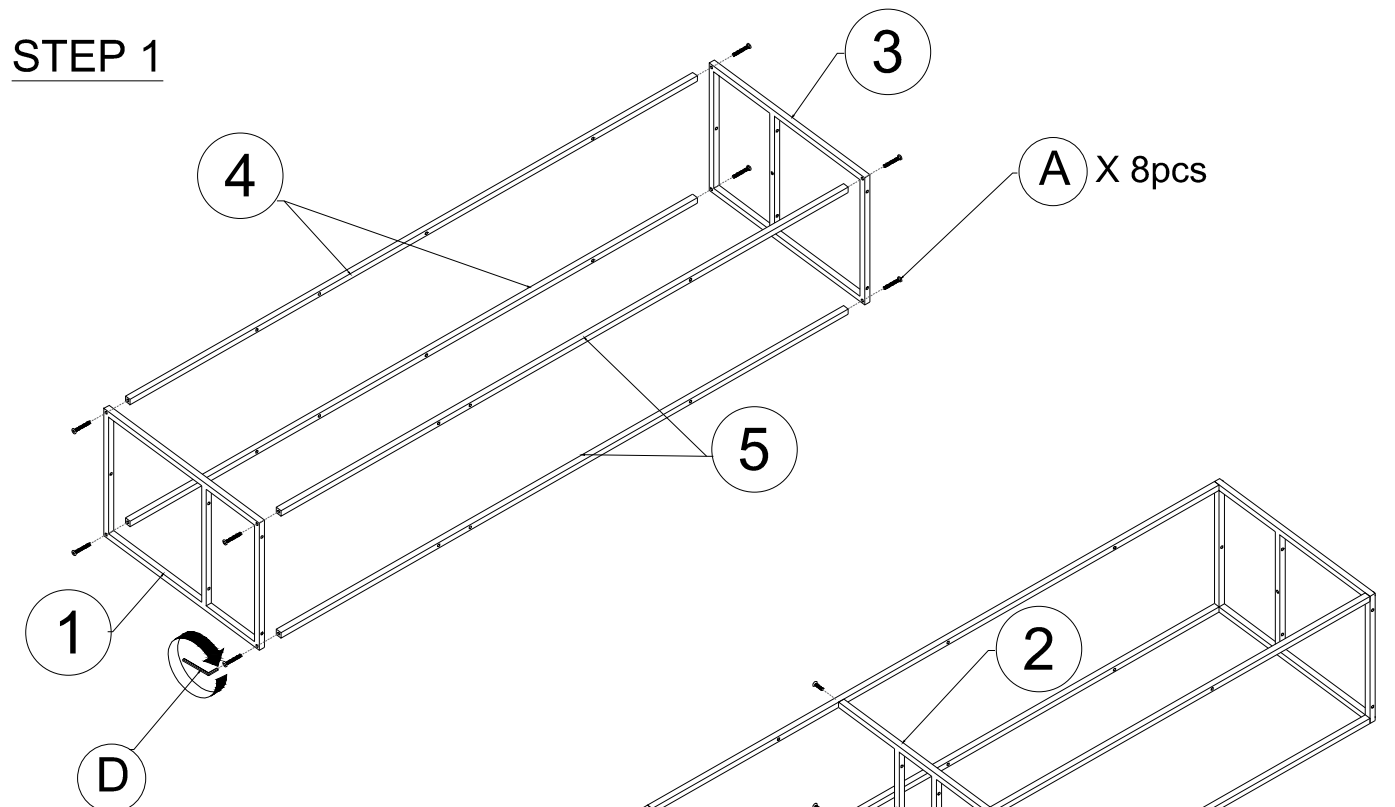

## STEP 2

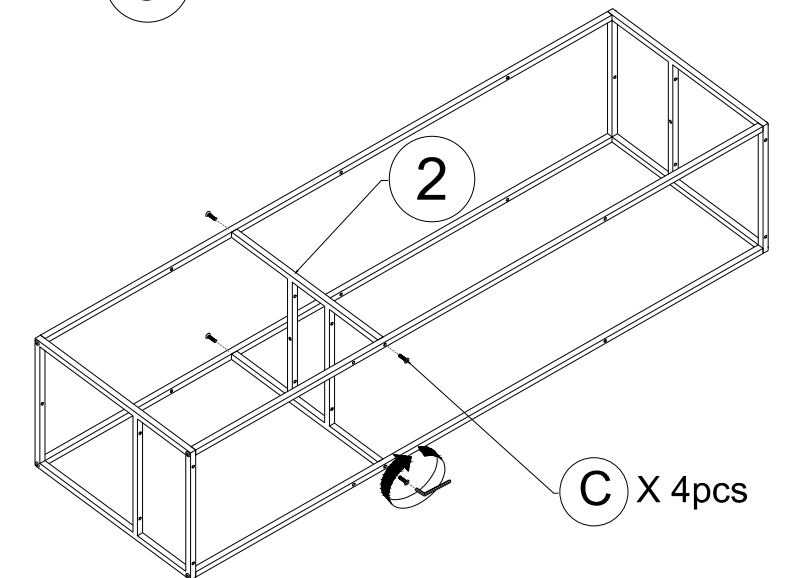

## STEP 3

