

ASSEMBLY INSTRUCTIONS

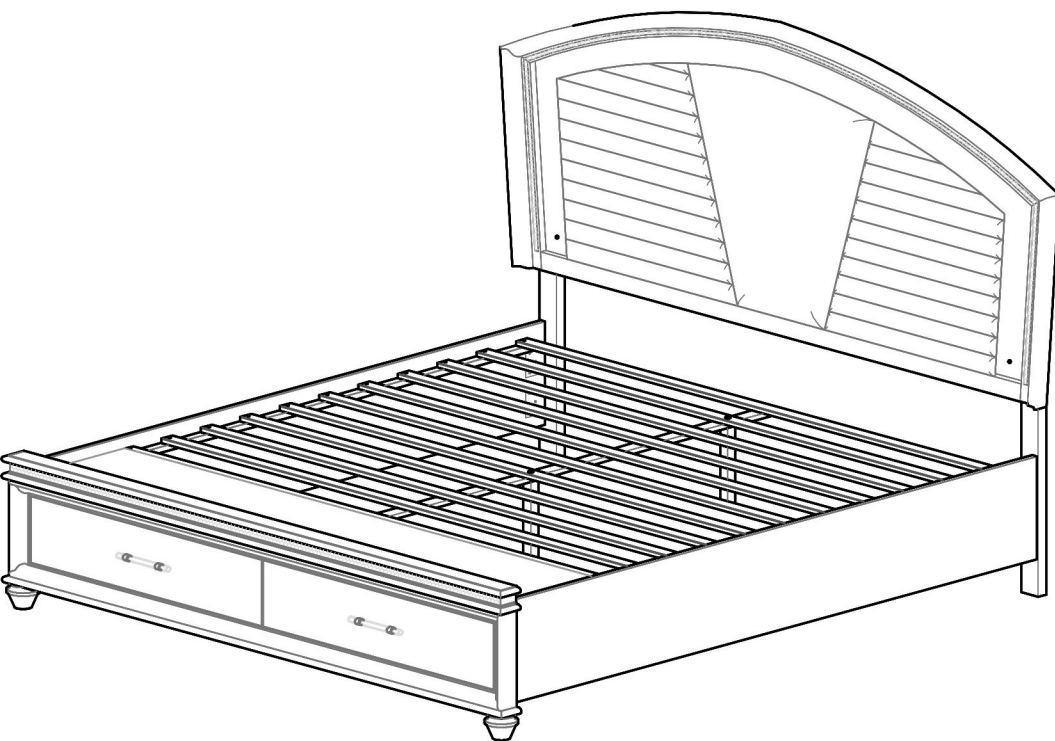

TOOLS REQUIRED



Allen Wrench

(Included)



Phillips
Screwdriver

(Not Included)

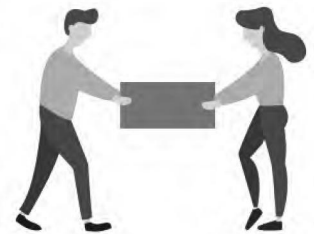

3 - People
Recommended

ASSEMBLY RATING



EASY —————> DIFFICULT

The Assembly Rating is a 5-point system showing the level of effort needed to assemble a specific product.



CHECK BEFORE STARTING

Are you missing anything?

Double-check all parts, hardware and accessories listed on Page 6 are accounted for.

Should we send any replacements?

Are there any irregularities or flaws in the parts? We can send replacements!

Check out our Quick Tips!

We recommend reviewing the pre-assembly handouts. Even experts need a refresher now and then!

Prep Time!

Please review the assembly instructions and all diagrams prior to assembling. Arrange parts as recommended on Page 7 and group identical hardware together to make assembling easier.

PRE ASSEMBLY INTRODUCTION

We understand building ready-to-assemble furniture can be a challenging experience for some. To help avoid confusion, we have provided some helpful tips that may speed up the process.

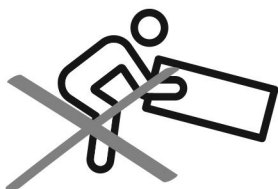

Teamwork

ALWAYS have at least two people to help with transporting and assembling the product to avoid potential injury and/or damage.

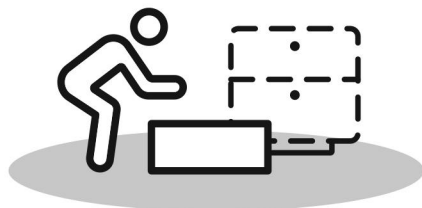
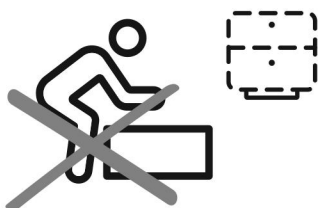

Suitable Location

Assembling near the area of the intended location is highly recommended.



Sufficient Space

Make sure you have enough space to move around during the assembly.



Avoid Scratches

Use cardboard, blankets or a carpeted area while assembling furniture to prevent scratches.

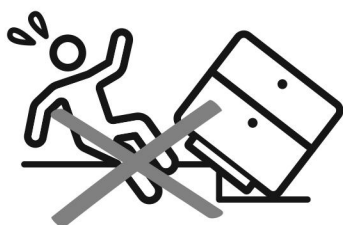

Flat Surface

Make sure the furniture rests on a flat and level surface with each leg evenly touching the floor.

ASSEMBLY AND CARE ADVICE



FAILURE TO FOLLOW THE GUIDELINES BELOW MAY RESULT IN INJURY AND/OR PROPERTY DAMAGE.



Position each part correctly and insert screws or bolts into their respective holes.

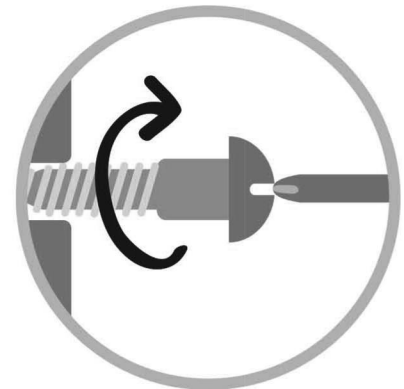

Turn clockwise to tighten and only tighten when step is completed or when instructed to do so.



Save the instructions and store any supplied tools for later maintenance.

Use the appropriate hand tools or power tools for assembly. Select steps, such as tightening screws and/or bolts, may require hand tools to avoid causing damage during assembly.



After two weeks, check and tighten any loose hardware and repeat again every six months thereafter.

IT IS THE USER'S RESPONSIBILITY TO MAINTAIN THE FURNITURE. THE HARDWARE MAY LOOSEN OVER TIME AND MAY CAUSE THE FURNITURE TO BE WOBBLY AND UNABLE TO SUPPORT ITS INTENDED WEIGHT CAPACITY. THIS MAY LEAD TO COLLAPSE AND MAY CAUSE SERIOUS INJURY.

KING BED



- Please keep instructions for future reference.
- Check the quantity and irregularity of parts and hardware before you start.

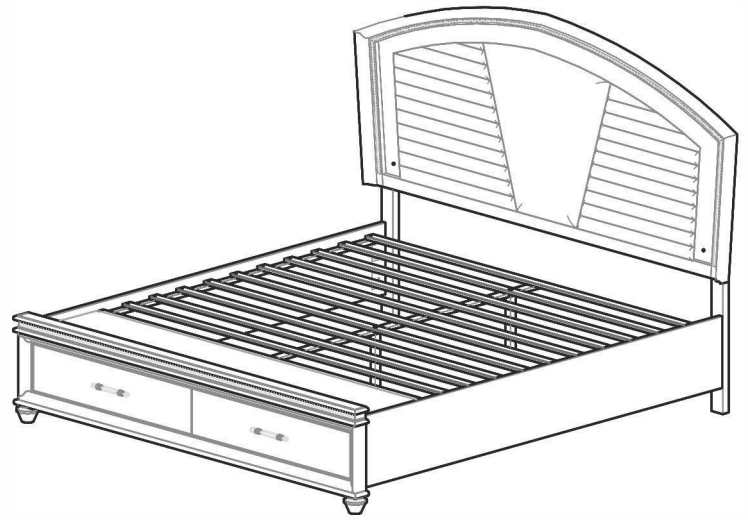

PARTS

PART LIST OF HEADBOARD

#1 1pc



Headboard

#2 1pc



Headboard Leg - (R)

#3 1pc



Headboard Leg - (L)

PART LIST OF FOOTBOARD

#4 1pc



Footboard

#5 2pcs



Acrylic Leg

#6 1pc



Drawer Support Rail

#7 2pcs



Drawer

#8 2pcs



Drawer Base Panel

#9 13pcs

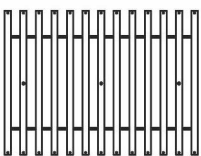

Roll Slat

#10 3pcs



Slat Support Leg

#11 1pc



Drawer Support Leg

#12 1pc



Slat Cover Panel

PART LIST OF SIDE RAIL

#13 2pcs



Side Rail

#14 1pc



Center Vertical Slat

HARDWARE

HARDWARE PACK IN HEADBOARD

#A 1pc



Allen Key

#B 6pcs



JCBC - M6 x 40mm

#C 6pcs



M6 Spring Washer

#D 6pcs



M6 Flat Washer

#E 1pc



AC Adapter

HARDWARE PACK IN FOOTBOARD

#F 1pc



Allen Key

#G 2pcs



JCBC - M6 x 16mm

#H 9pcs



JCBC - M6 x 35mm

#I 3pcs



JCBC - M6 x 60mm

#J 14pcs



M6 Spring Washer

#K 7pcs



M6 Flat Washer

#L 4pcs



1/4" Flat Washer

#M 26pcs



Screw 32mm

#N 2pcs













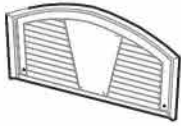

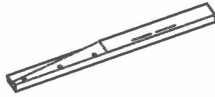

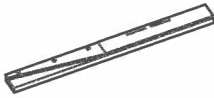







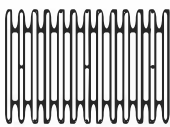

Screw 16mm

#O 4pcs

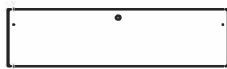
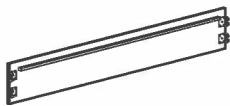

Adjustable Leveller

POINT 4 CARTONS

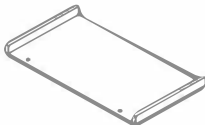
Carton	Designation		Part	Hardware
	Headboard (1pc)	#1		 #A x 1pc  #B x 6pcs
	Headboard Leg - (R) (1pc)	#2		 #C x 6pcs  #D x 6pcs
	Headboard Leg - (L) (1pc)	#3		 #E x 1pc
	Footboard (1pc)	#4		 #F x 1pc  #G x 2pcs
	Bun Foot	#5		 #H x 9pcs  #I x 3pcs
	Drawer Support Rail (1pc)	#6		 #J x 14pcs
	Roll Slat (13pcs)	#9		 #K x 7pcs  #L x 4pcs
	Slat Support Leg (3pcs)	#10		 #M x 26pcs
	Drawer Support Leg (1pc)	#11		 #N x 2pcs  #O x 4pcs
	Slat Cover Panel (1pc)	#12		
	Side Rail (2pcs)	#13		
	Center Vertical Slat (1pc)	#14		
	Drawer (2pcs)	#7		
	Drawer Base Panel (2pcs)	#8		

ASSEMBLY INSTRUCTIONS

1 Part #1 x 1pc

Part #2 x 1pc

Part #3 x 1pc

Hardware #A x 1pc

Hardware #B x 6pcs

Hardware #C x 6pcs

Hardware #D x 6pcs

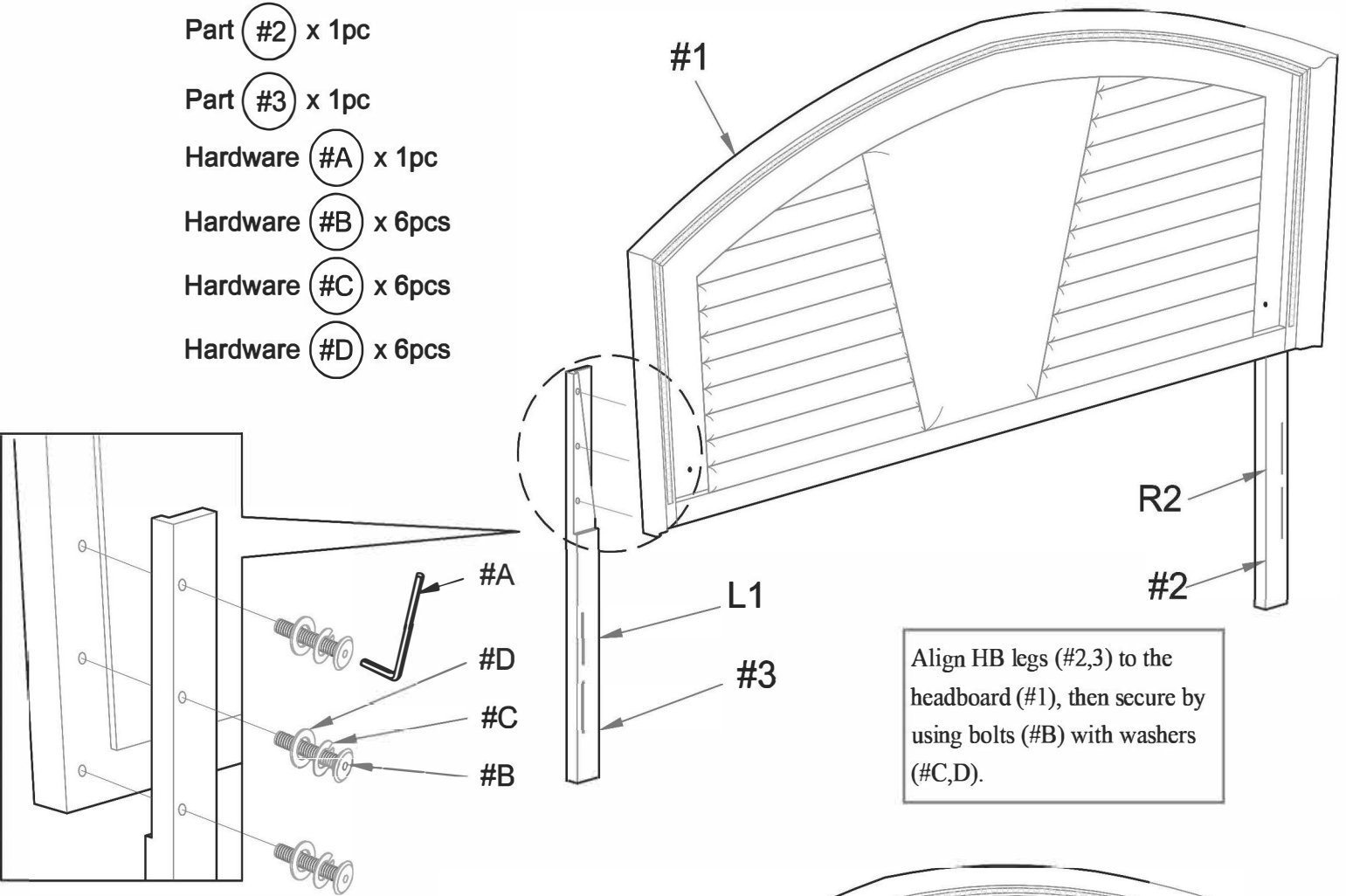

2 Part #1 x 1pc

Hardware #E x 1pc

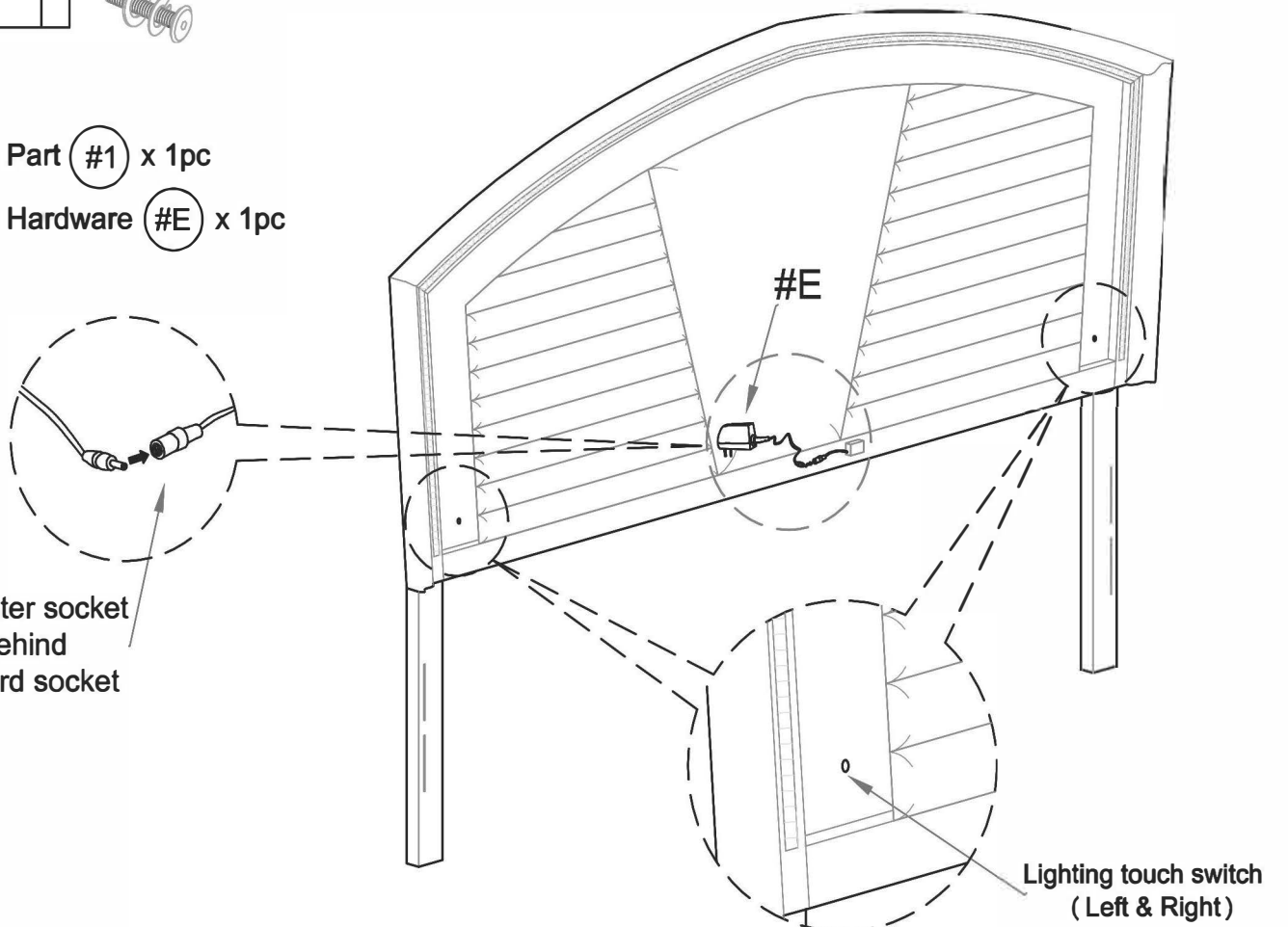

ASSEMBLY INSTRUCTIONS

3

Part #4 x 1pc

Part #5 x 2pcs

Attach legs (#5) to the footboard (#4).

Bun Foot cover

Remove Acrylic Leg cover before assemble.

#5

#5

#4

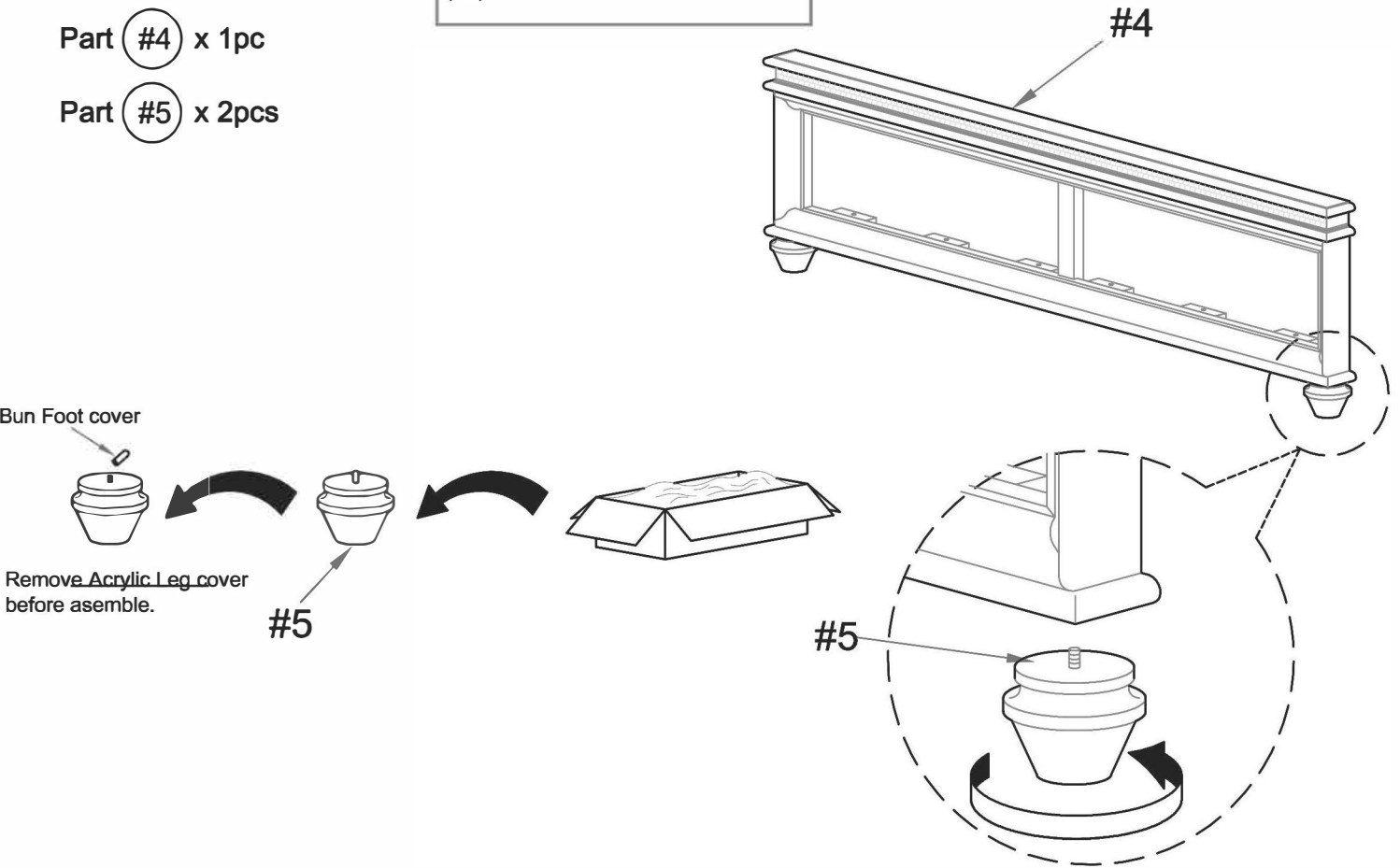

4

Part #1 x 1pc

Part #4 x 1pc

Part #13 x 2pcs

Align and hook the side rails (#13) to the latches on the headboard (#1) and footboard (#4). Make sure it is firmly in place.

#1

#13

#4

#13

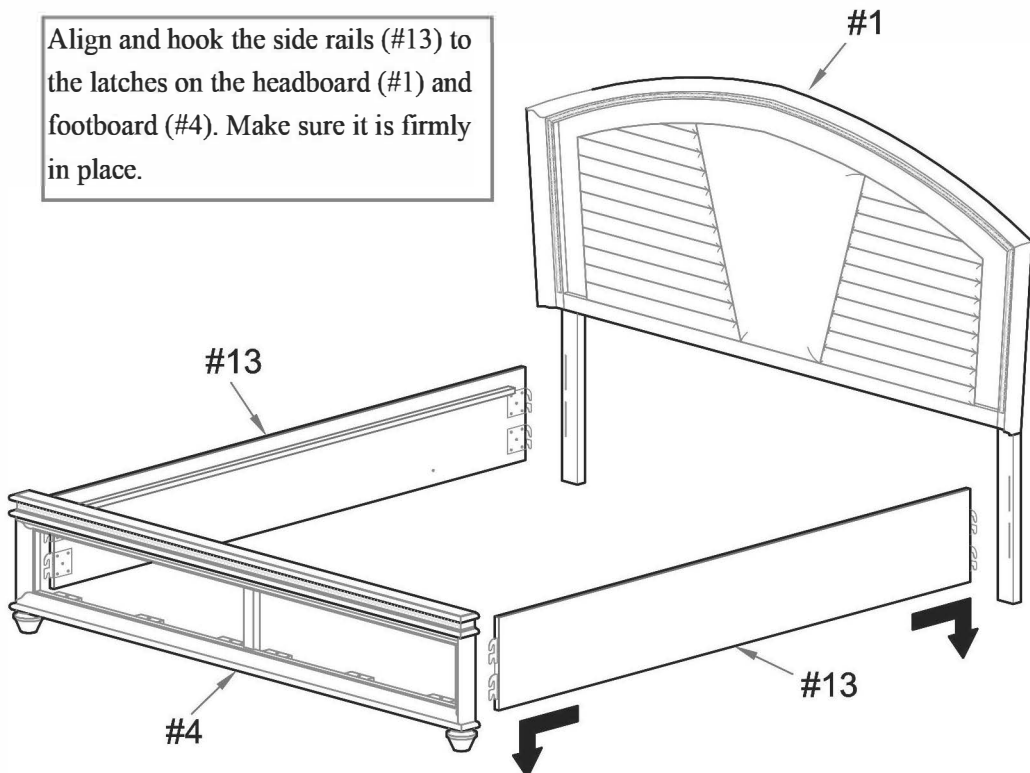

ASSEMBLY INSTRUCTIONS

5

- Part (#6) x 1pc
- Hardware (#F) x 1pc
- Hardware (#G) x 2pcs
- Hardware (#J) x 2pcs
- Hardware (#K) x 2pcs

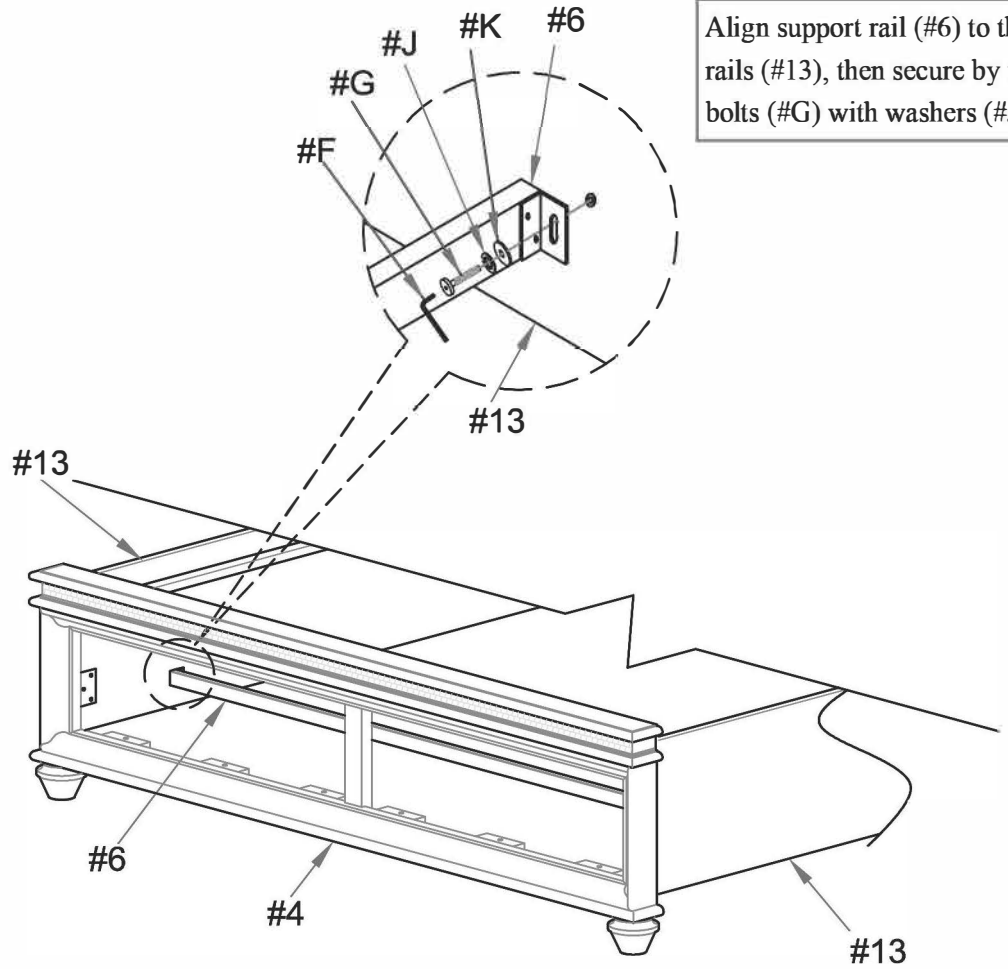

Align support rail (#6) to the side rails (#13), then secure by using bolts (#G) with washers (#J,K).

6

Make sure to fully extend rails to see the black switch on the rails.

Step to remove the drawer :

1. Pull the drawer
2. Using both hands,
 - Left hands side - pull up switch
 - Right hands side - pull down switch
3. Then remove the drawer from the drawer base panel

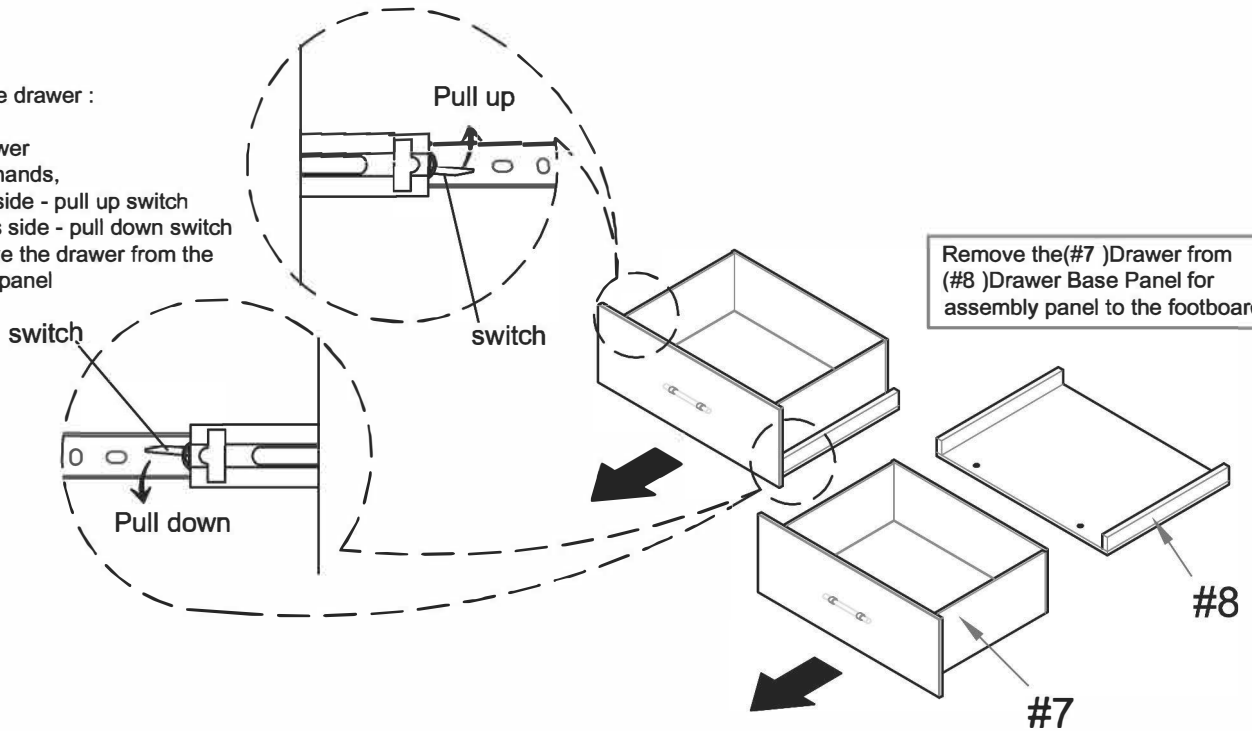

Remove the (#7) Drawer from (#8) Drawer Base Panel for assembly panel to the footboard.

ASSEMBLY INSTRUCTIONS

7

- Part (#8) x 2pcs
- Hardware (#F) x 1pc
- Hardware (#H) x 8pcs
- Hardware (#J) x 8pcs
- Hardware (#K) x 4pcs
- Hardware (#L) x 4pcs

Align base (#8) to the footboard (#4), then secure by using bolts (#H) with washers (#J,K).

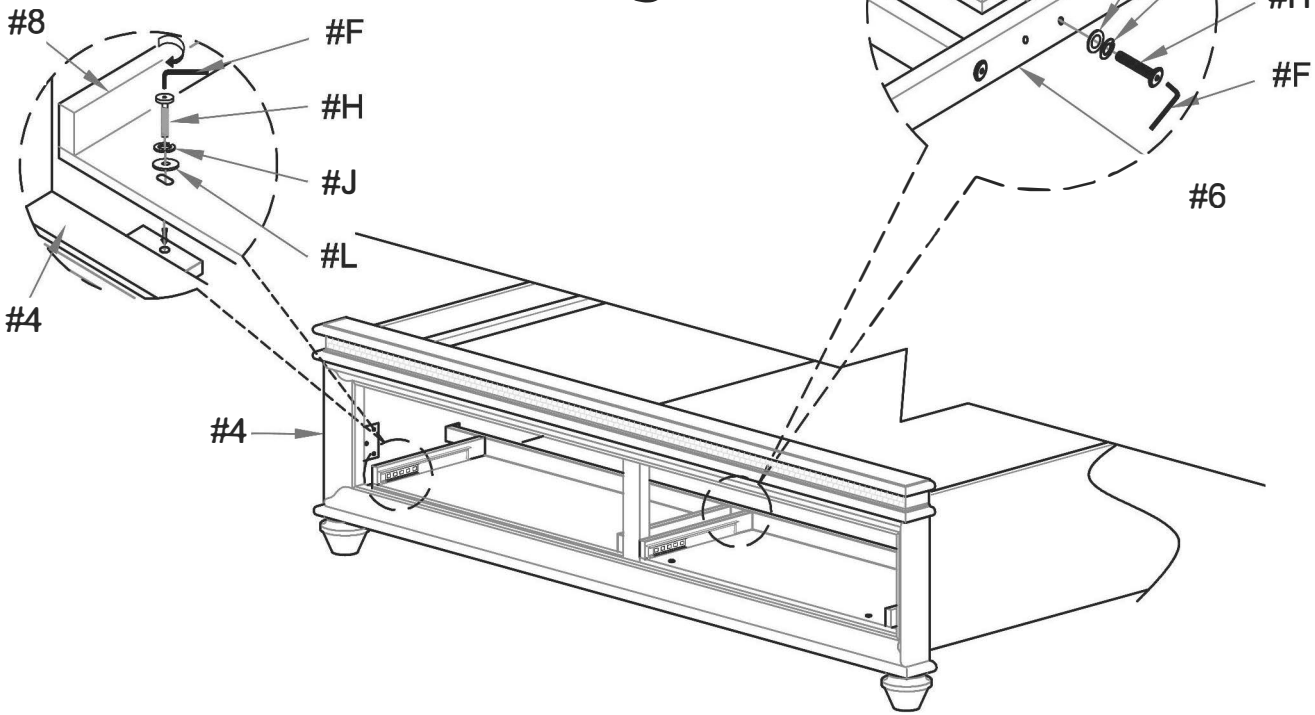

8

- Part (#11) x 1pc
- Hardware (#F) x 1pc
- Hardware (#H) x 1pc
- Hardware (#J) x 1pc
- Hardware (#K) x 1pc
- Hardware (#O) x 1pc

Align support leg (#11) to the support rail (#6), then secure by using bolts (#H) with washers (#J,H).

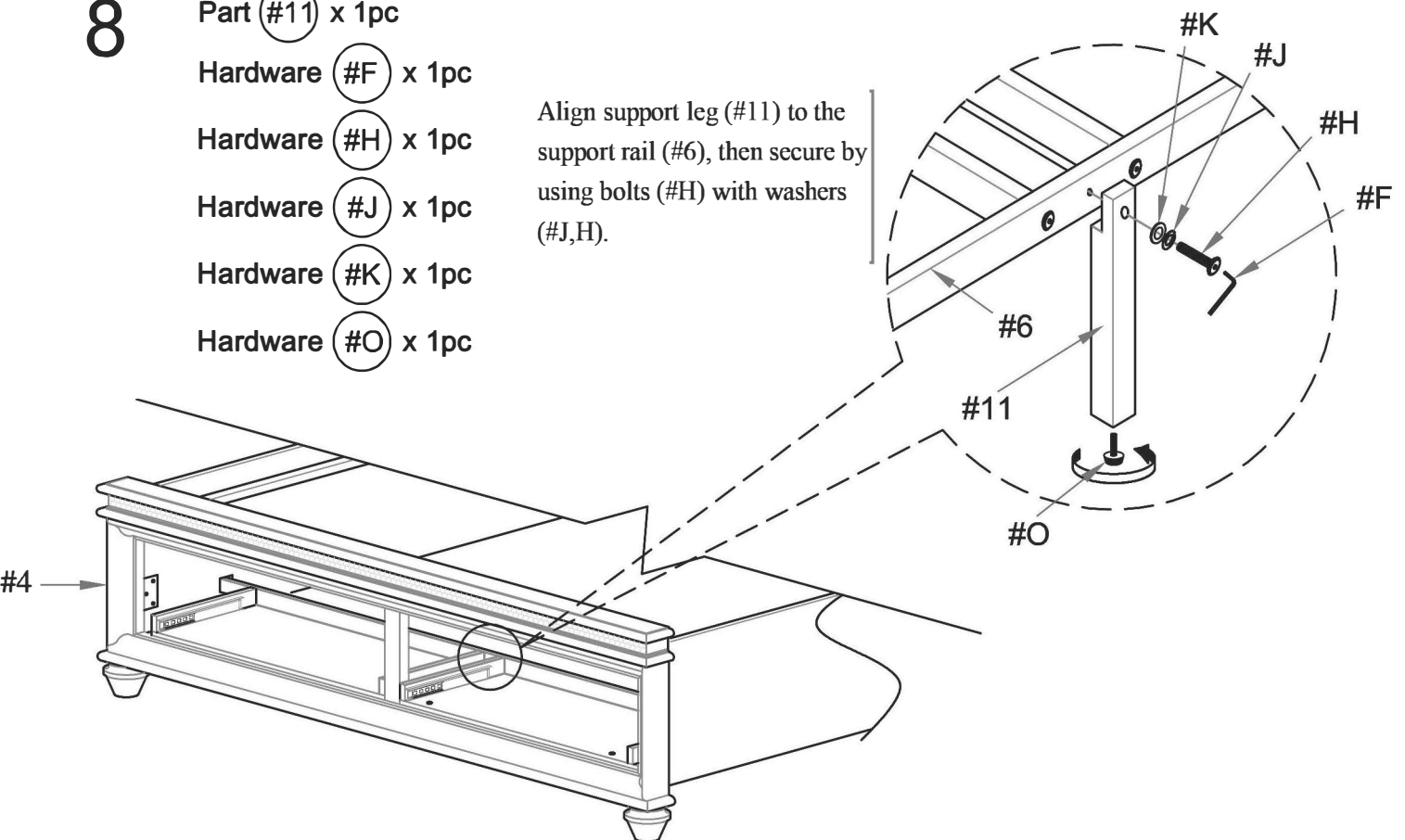

ASSEMBLY INSTRUCTIONS

9

Step to install the drawer on the drawer base panel :

***Prefer 2 person to install the drawer

1. Adjust the ball bearing plate to the front as a diagram shows.
2. Then attach the drawer to the drawer base panel and install with carefully.

Insert the drawer (#G) to the footboard (#D)

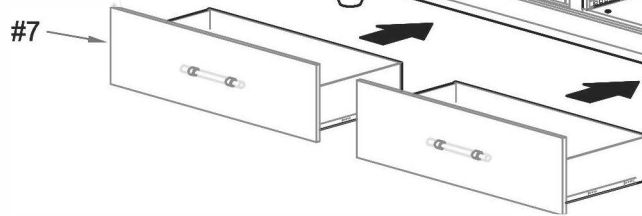

Align and connect the rails of the drawer base to the drawers.

10

Part (#9) x 13pcs Hardware (#F) x 1pc

Part (#10) x 3pcs Hardware (#I) x 3pcs

Part (#14) x 1pc Hardware (#J) x 3pcs

Hardware (#M) x 26pcs

Hardware (#O) x 3pcs

1) Align slats (#9) to the side rails (#13), then secure by using screws (#M).

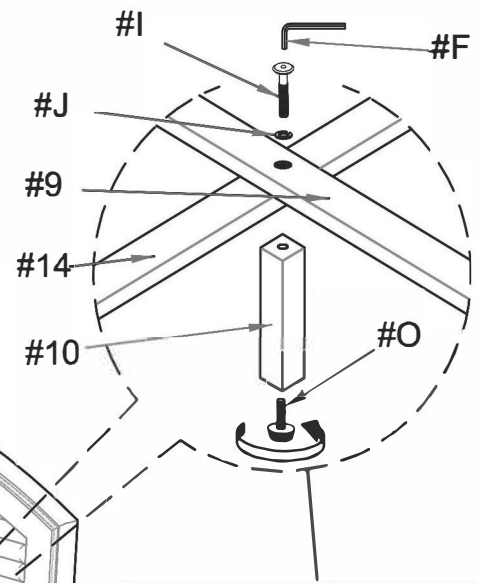
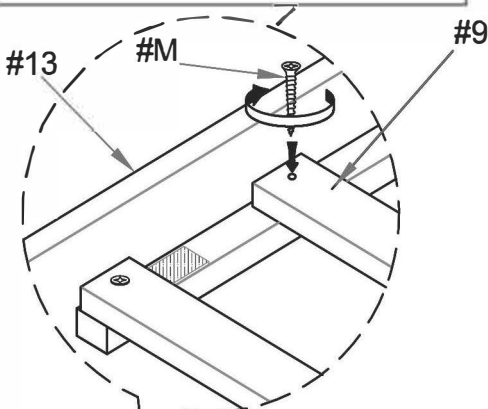

2) Align center support slat (#14) to the slats (#9), then secure by using bolts (#I) with washers (#J) onto support legs (#10). Attach levelers (#O) to the support legs (#10).

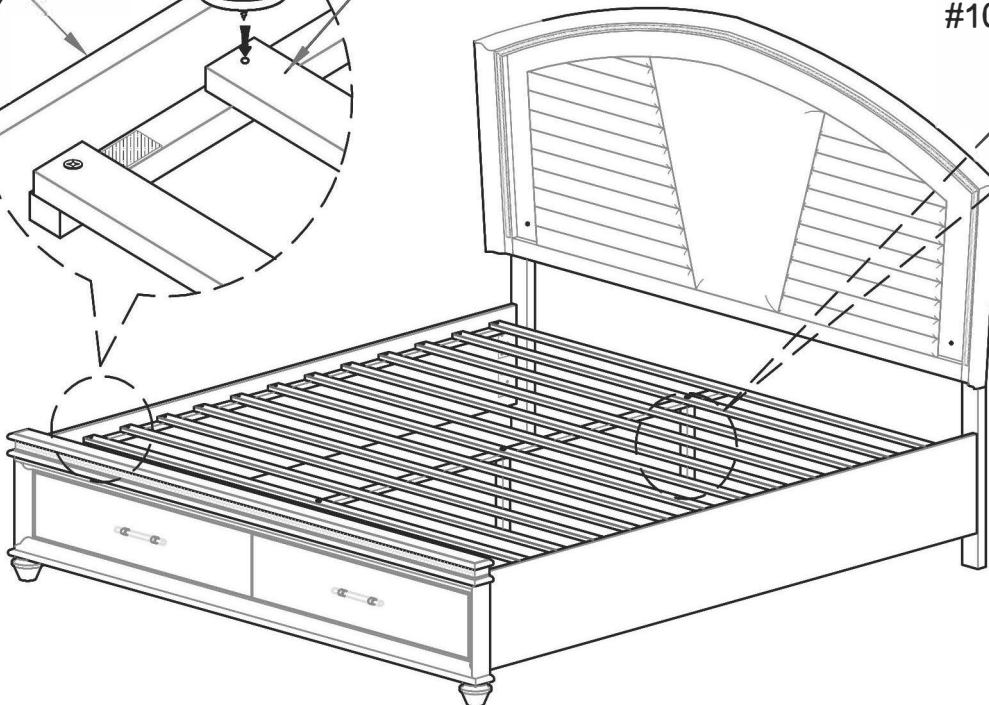

ASSEMBLY INSTRUCTIONS

11

Part #12 x 1pc

Hardware #N x 2pcs

Align slat cover panel (#12) to the footboard end of the bed, then secure by using screws (#N).

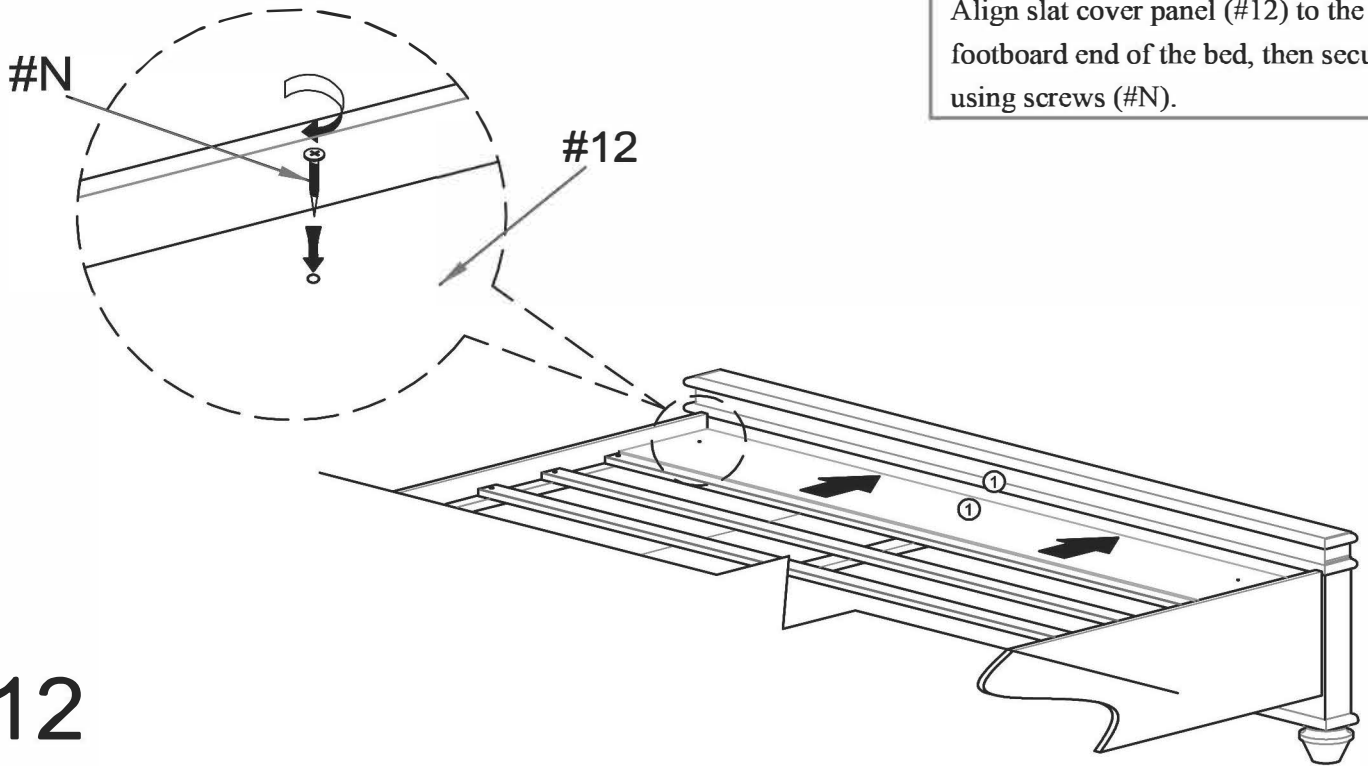

12

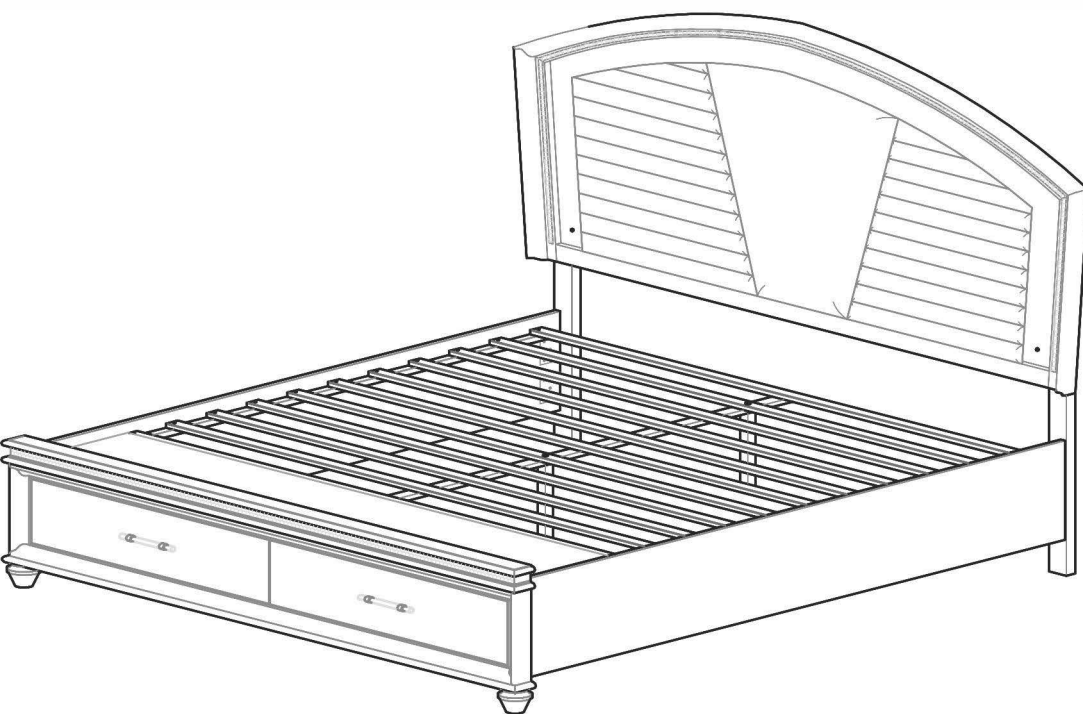

ASSEMBLY COMPLETED



Please ensure the furniture rests on an even and flat surface. If the product wobbles or feels loose, double-check all bolts and/or screws are properly tightened and secured.



Keep this handy!

Please retain this instruction manual and any order-related information for future reference.



Lift, don't drag!

To avoid damage to product please always LIFT the product when transporting or adjusting the placement.