

# ASSEMBLY INSTRUCTIONS

## Important Safety Instructions:

- Please read all instructions before beginning assembly
- Please make sure receive all the parcels to start the assembly
- For your safety and convenience, assembly by two people is recommended
- Use the parts and hardware lists to identify and separate each of the components included
- Save all packing materials until assembly is completed to avoid the accidental discarding of smaller parts or hardware

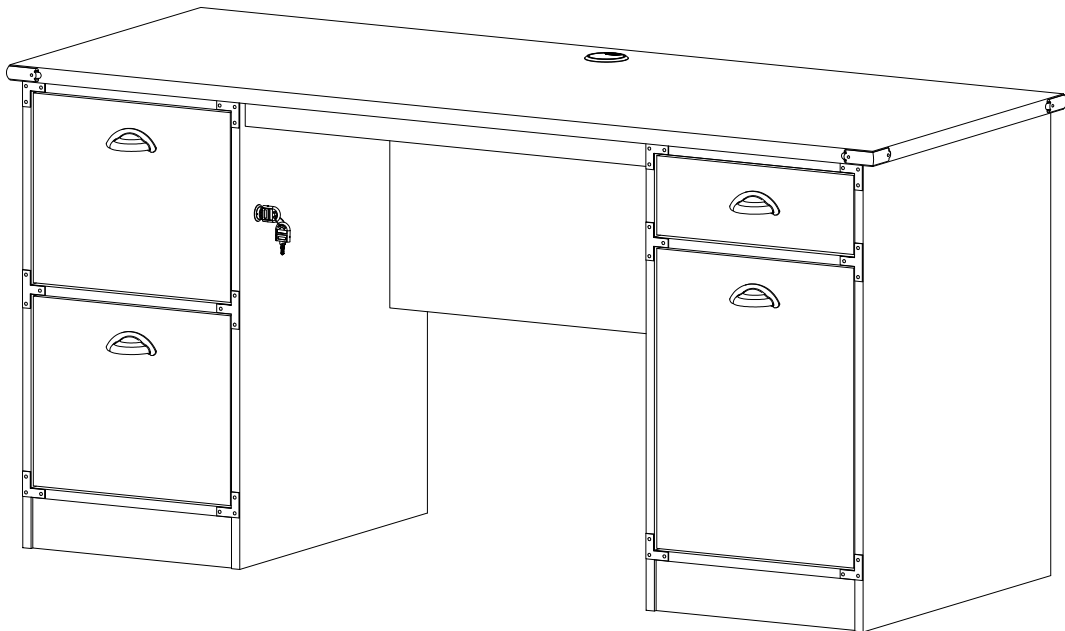





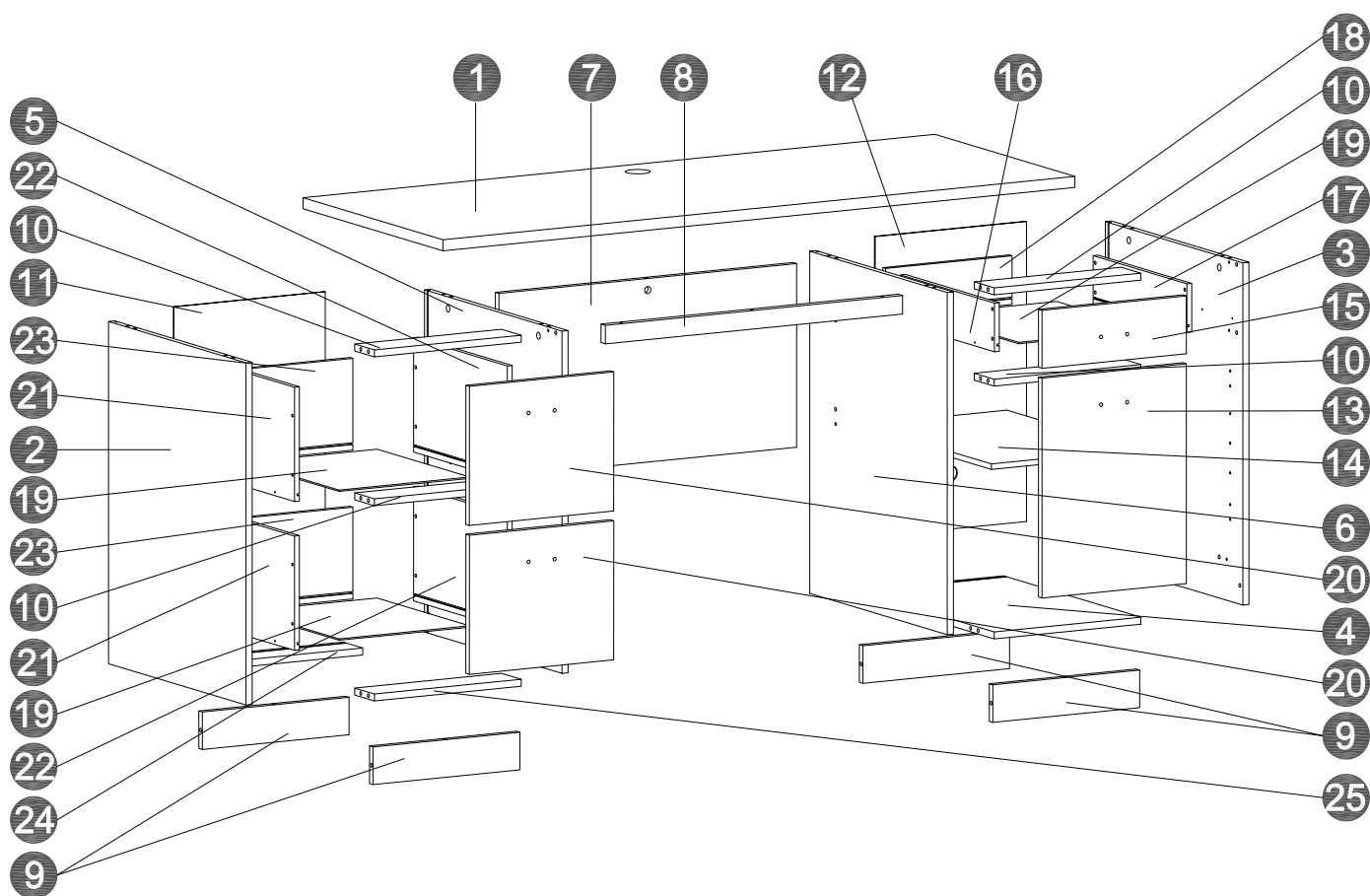

THANK YOU FOR PURCHASING

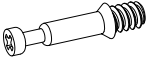

# PARTS LIST

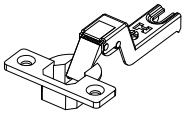
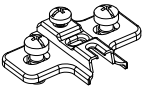
① X1	② X1	③ X1	④ X1	⑤ X1
⑥ X1	⑦ X1	⑧ X1	⑨ X4	⑩ X4
⑪ X1	⑫ X1	⑬ X1	⑭ X1	⑮ X1
⑯ X1	⑰ X1	⑱ X1	⑲ X3	⑳ X2
㉑ X2	㉒ X2	㉓ X2	㉔ X1	㉕ X1

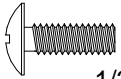
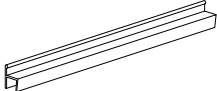
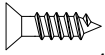
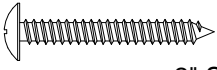
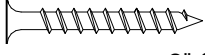
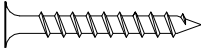
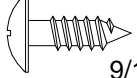
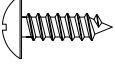

# HARDWARE LIST

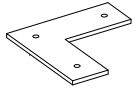
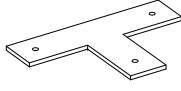
Name	Part	Qty.	Spare
A		25	1
B		25	1
C		40	2
D		2	
E		2	
F		4	
G	 1/2" Screw	8	1
H		4	
I	 1/2" Screw	36	4
J	 2" Screw	3	1
K	 2" Screw	4	1
L	 1-1/2" Screw	12	1
M	 9/16" Screw	12	1
N	 1/2" Screw	12	1
O		36	3

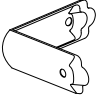
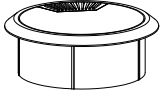
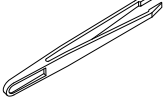
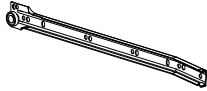
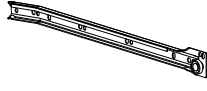
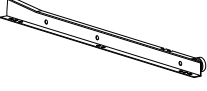
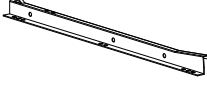
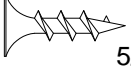
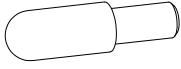
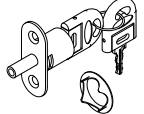
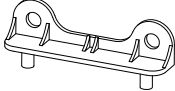
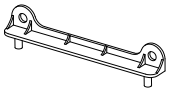
Name	Part	Qty.	Spare
P		8	
Q		4	
R	 5/6" nail	8	2
S		4	
T		1	
U		1	
V	 16"	3	
W	 16"	3	
X	 16"	3	
Y	 16"	3	
Z	 5/8" Screw	6	
AA		4	
BB		1	
CC		2	
DD		4	

# STEP 1

CC x 2pcs 

DD x 4pcs 

M x 12pcs 

Do not use power screw driver,  
use manual screw driver.

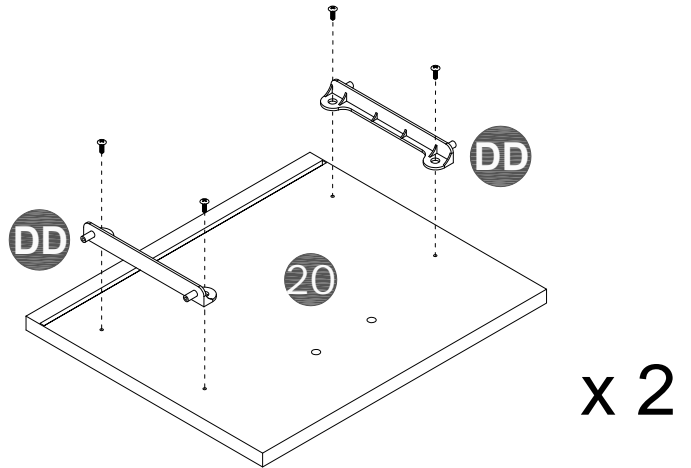
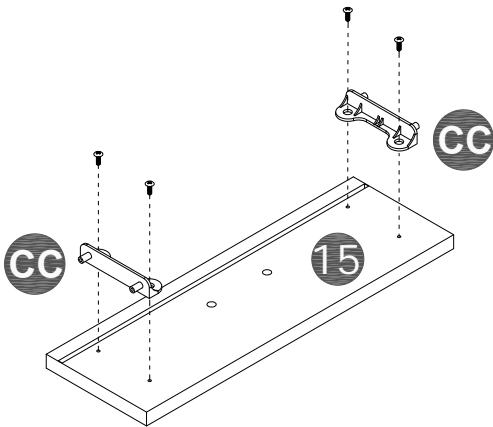

# STEP 2

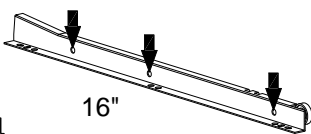
X x 3pcs \*  16"

I x 18pcs 

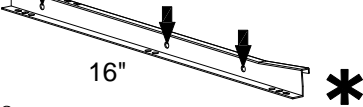
Y x 3pcs  16"

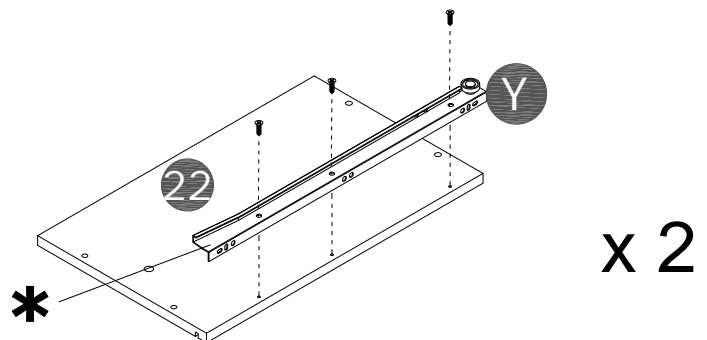
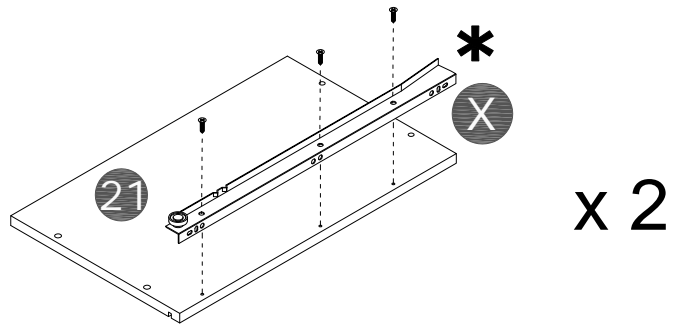
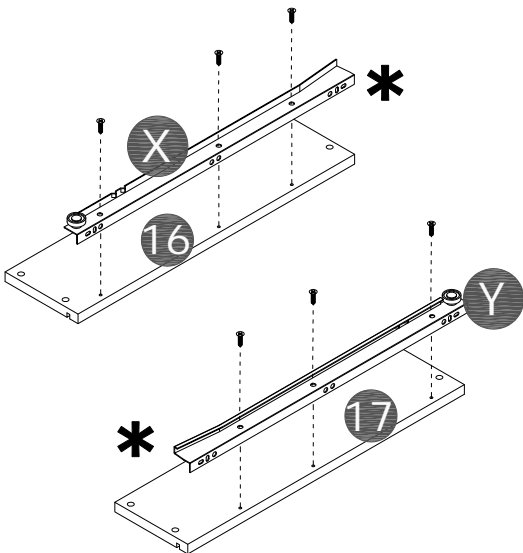

## STEP 3

**N** x 12pcs 

**L** x 12pcs 

Do not use power screw driver,  
use manual screw driver.

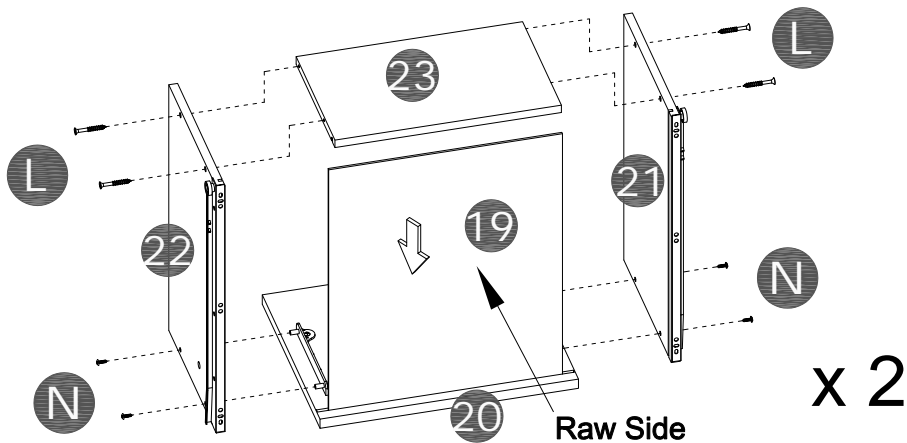
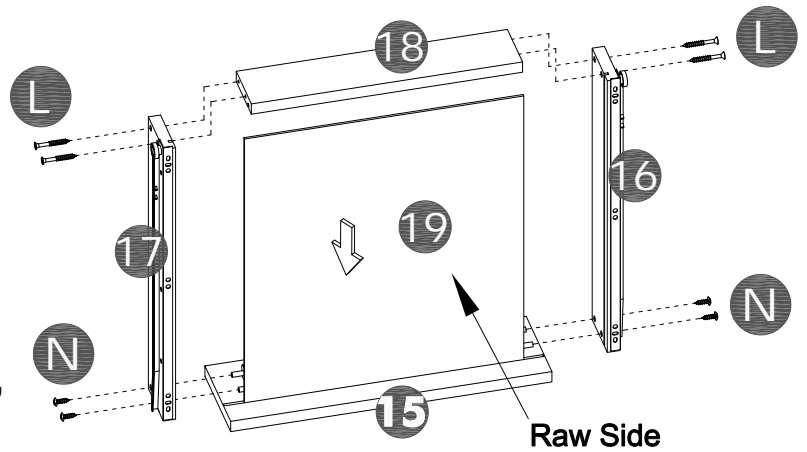

## STEP 4

**F** x 3pcs 

**H** x 4pcs 

**G** x 6pcs 

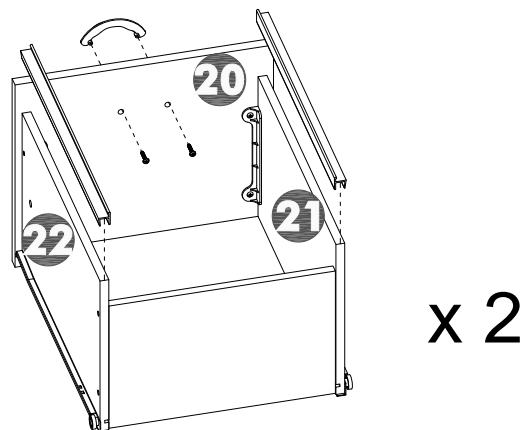
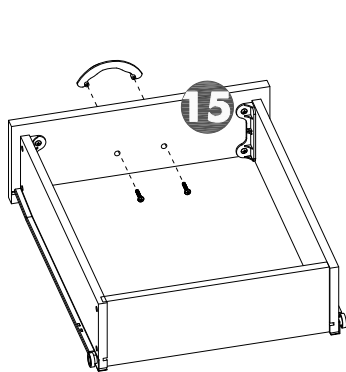

# STEP 5

V x 2pcs

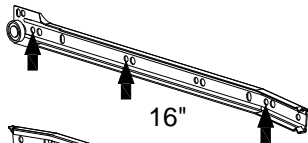

W x 2pcs

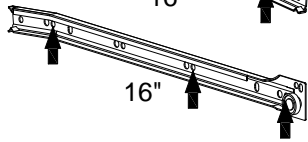

I x 12pcs

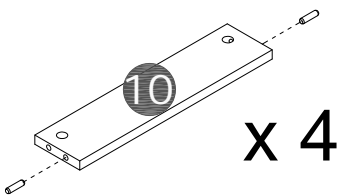
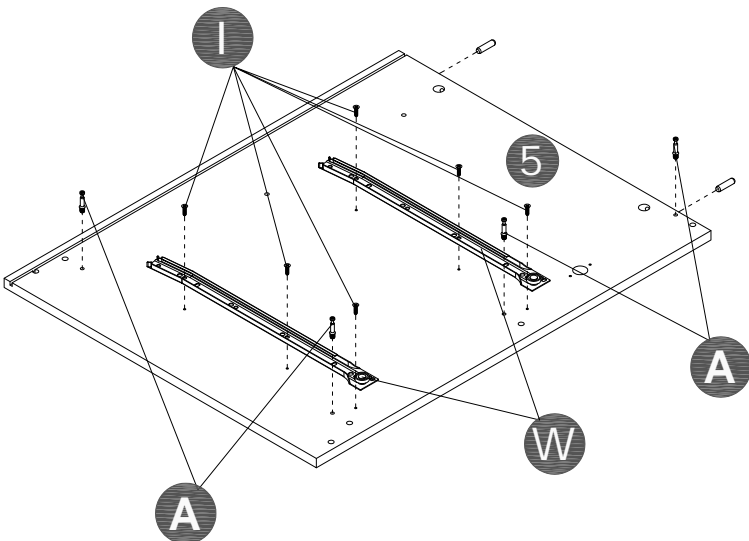
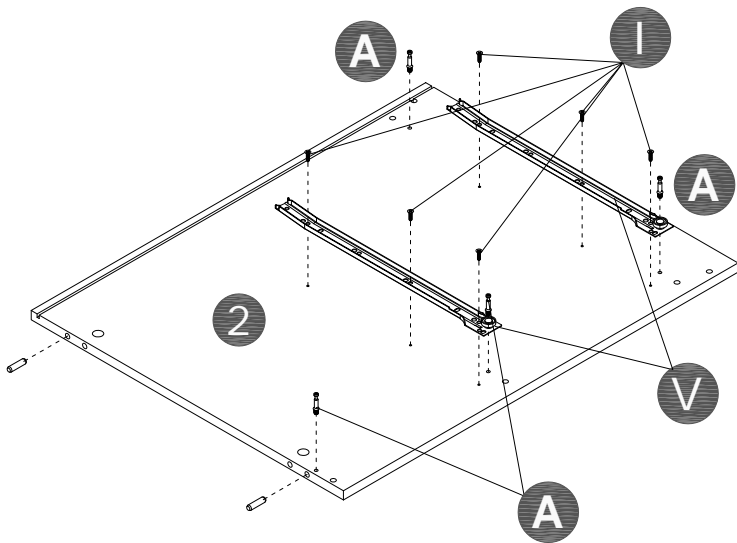
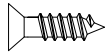

x 4

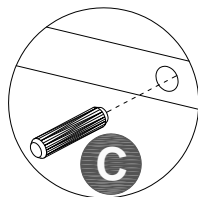

A x 8pcs

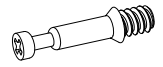

C x 32pcs

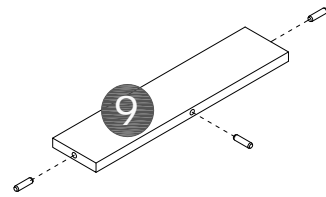
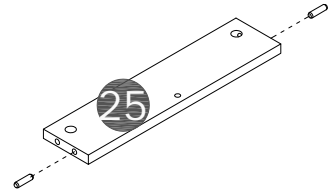
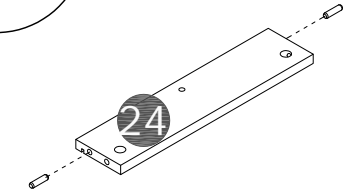
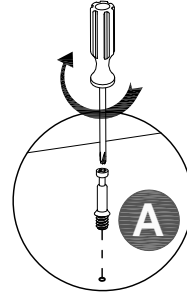
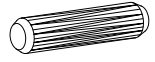

x 4

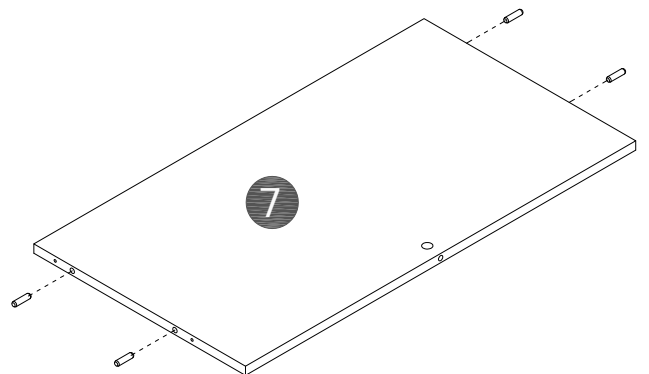

# STEP 6

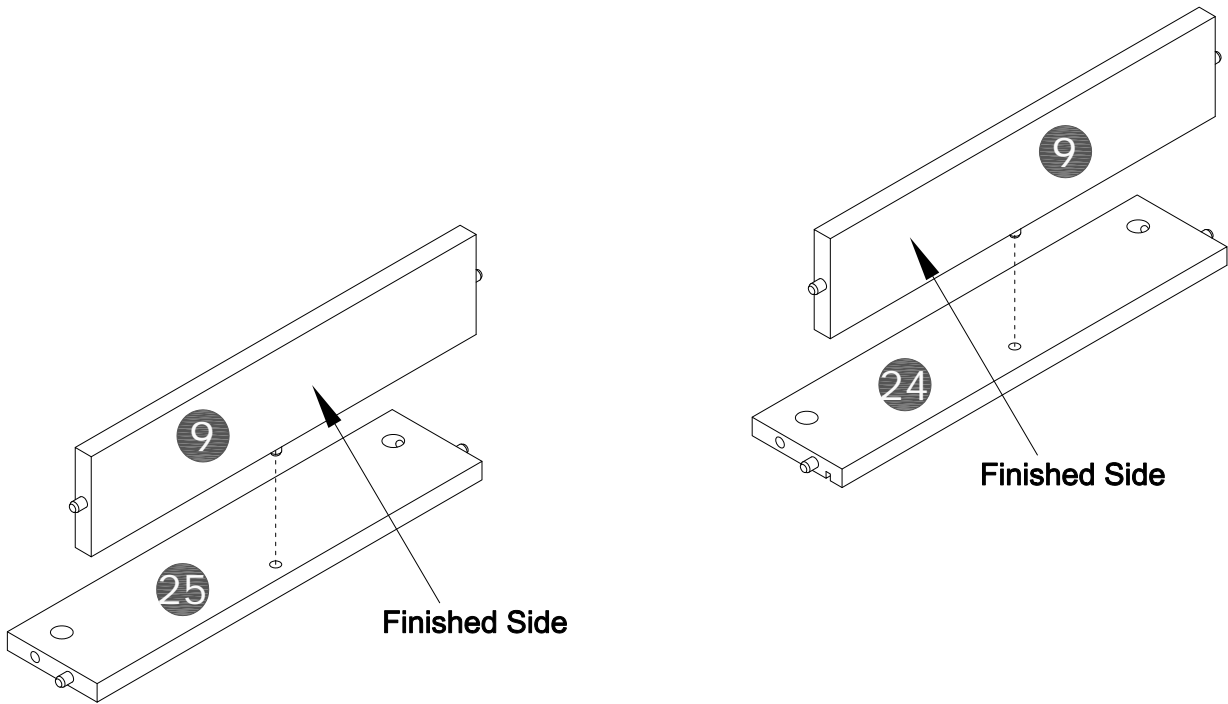

# STEP 7

**B** x 8pcs

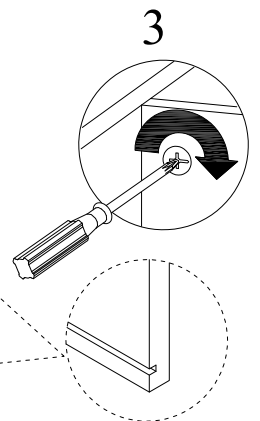
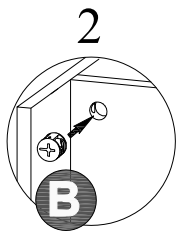
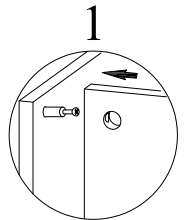
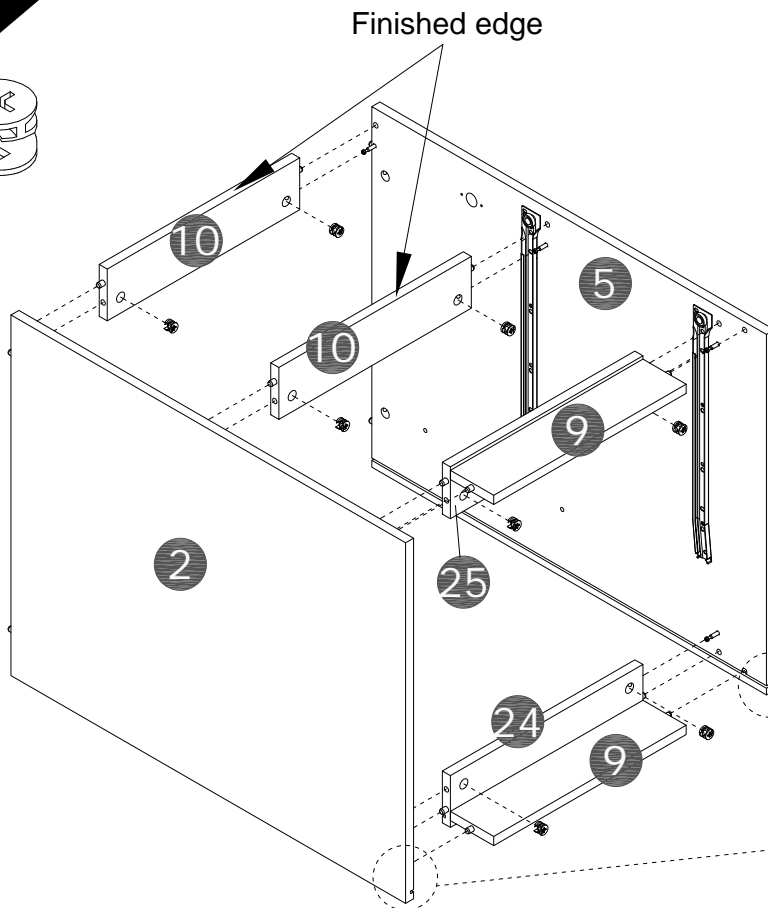

## STEP 8

**O** x 18pcs 

**P** x 4pcs 

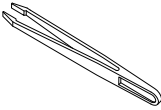
**U** 

**Q** x 2pcs 

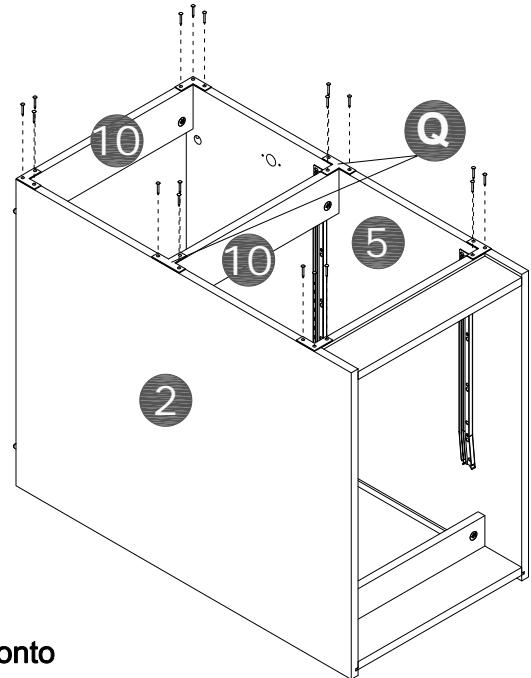
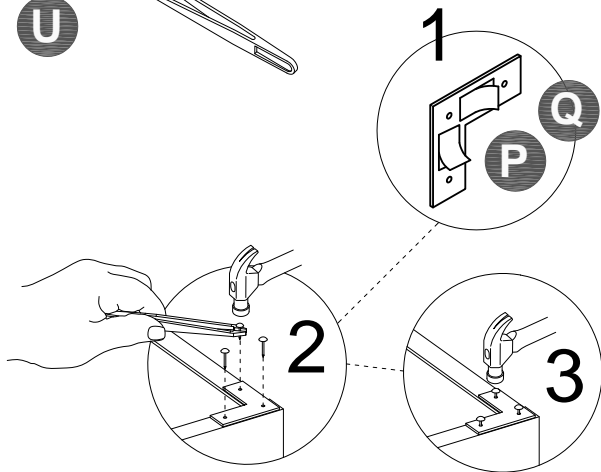

Peel off the adhesive sticker's protective paper and bond it onto the designated position before secure with nails.

## STEP 9

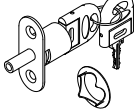
**BB** x 1pc 

**Z** x 2pcs 

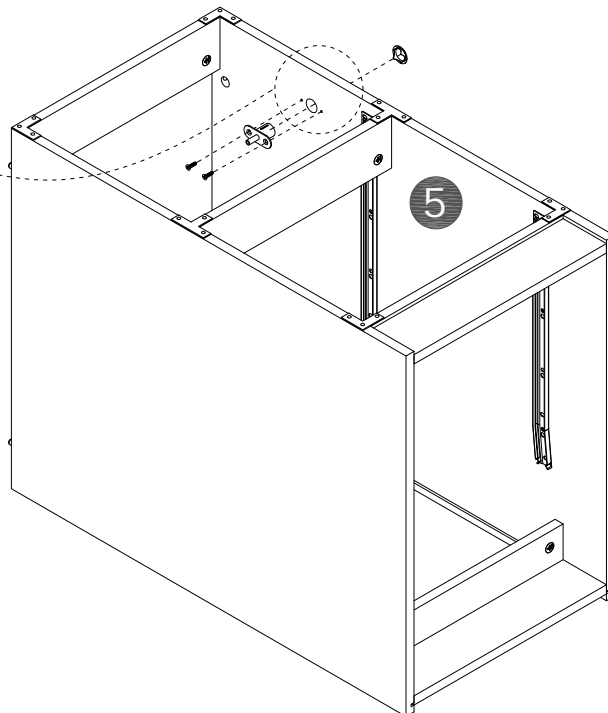
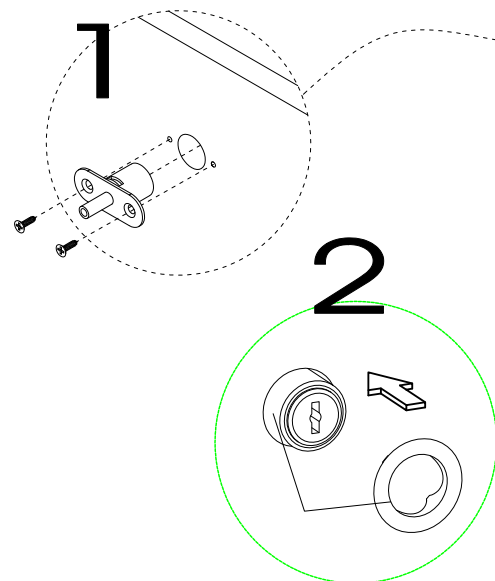

LOCKED



UNLOCKED

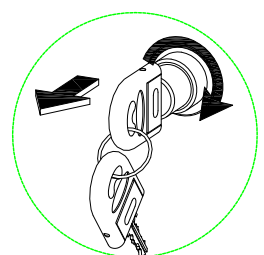



# STEP 11

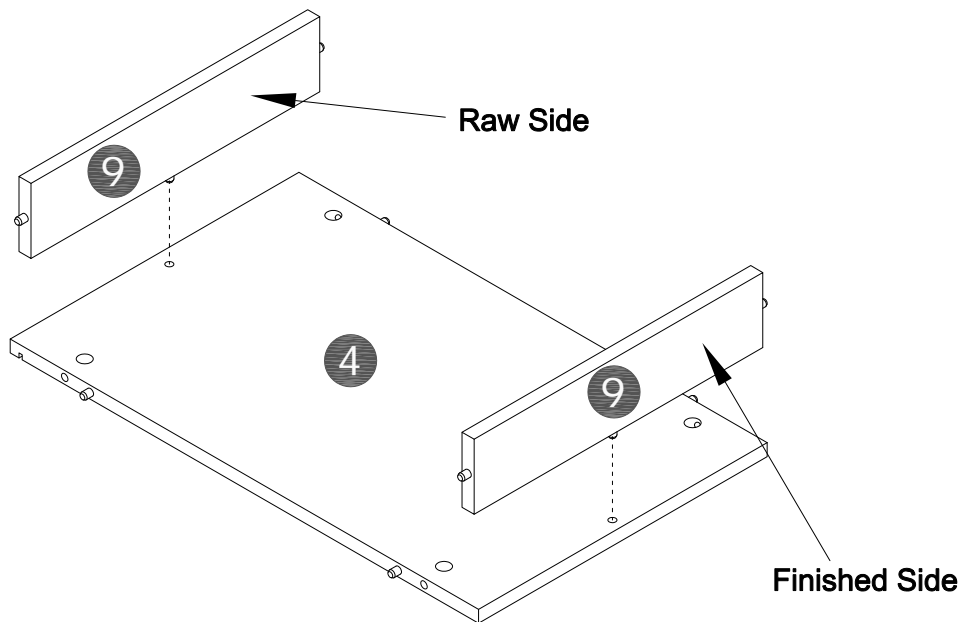

# STEP 12

**B** x 8pcs

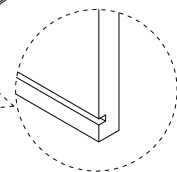
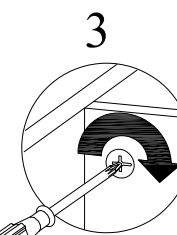
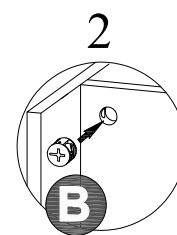
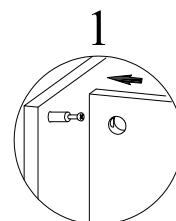
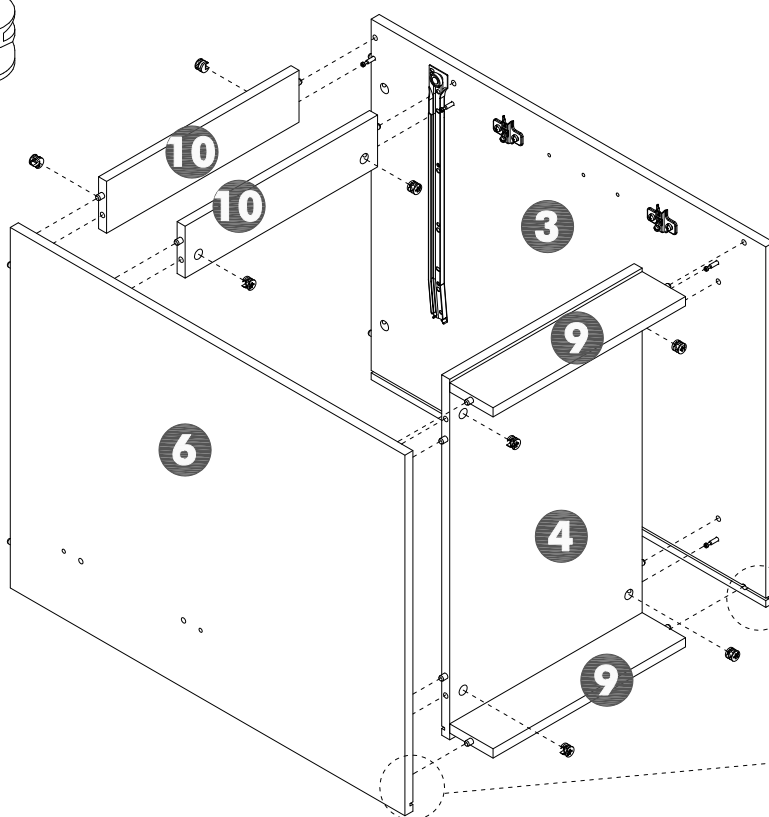

## STEP 13

**O** x 18pcs 

**Q** x 2pcs 

**P** x 4pcs 

**U** 

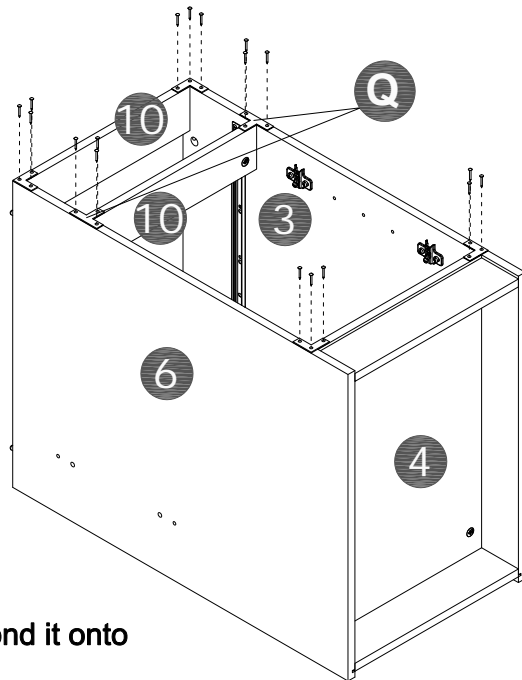
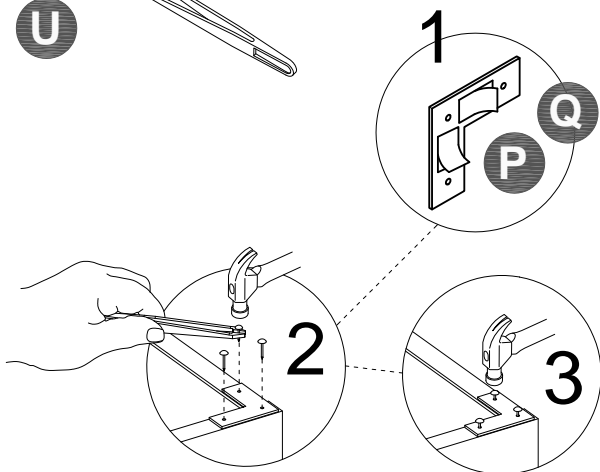

Peel off the adhesive sticker's protective paper and bond it onto the designated position before secure with nails.

## STEP 14

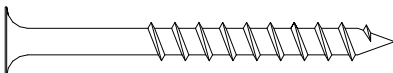
**K** x 4pcs 

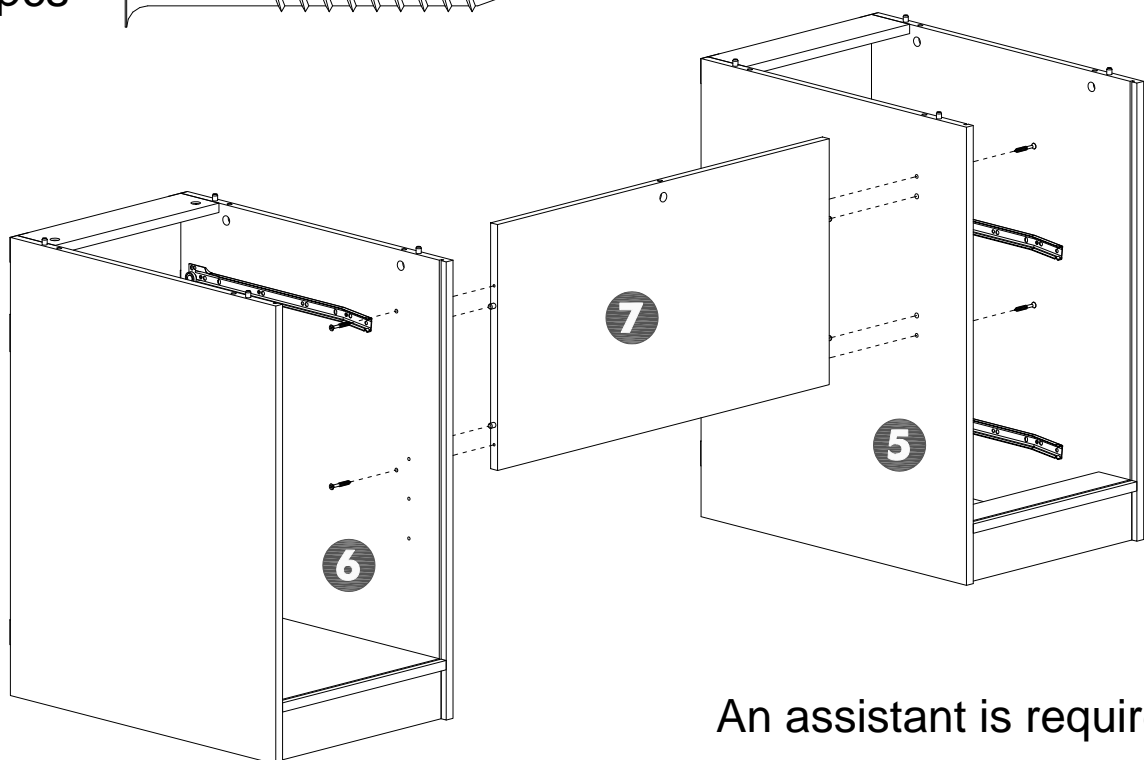

An assistant is required.

# STEP 15

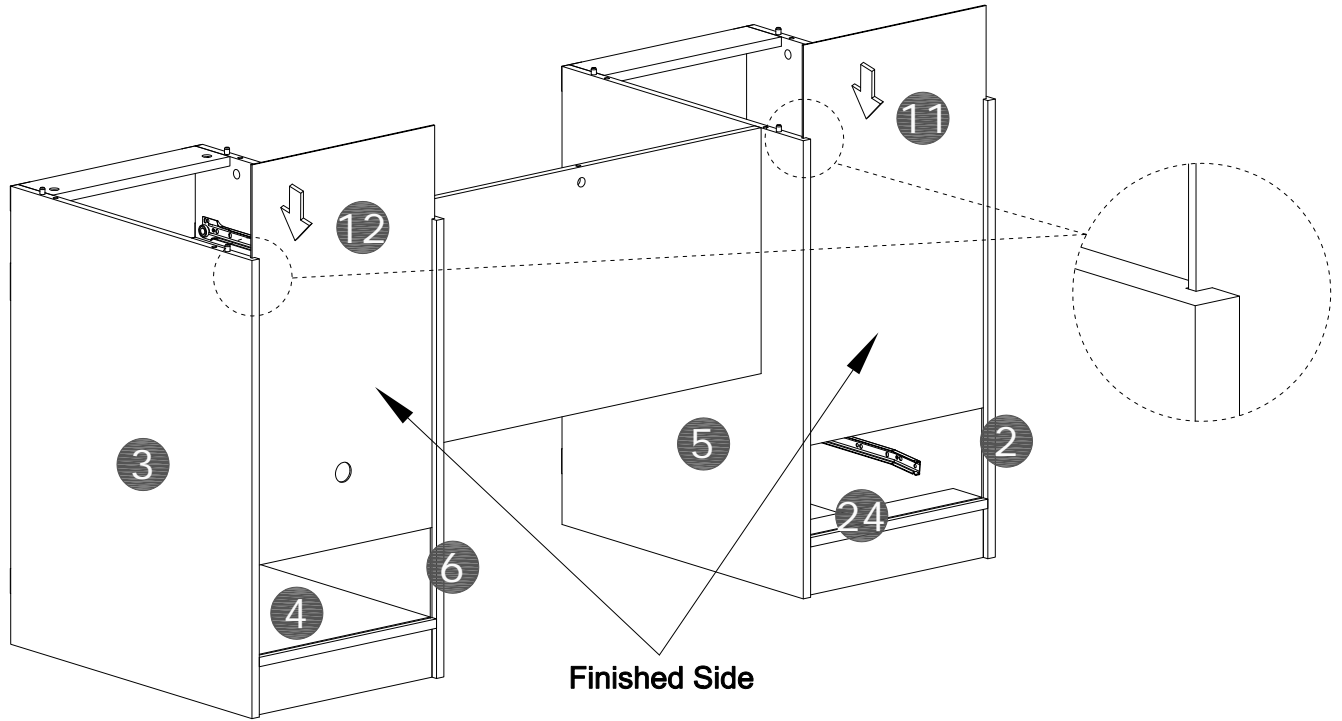

# STEP 16

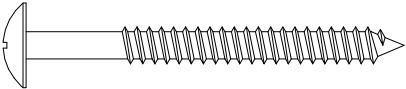
● J x 3pcs 

● A x 9pcs 

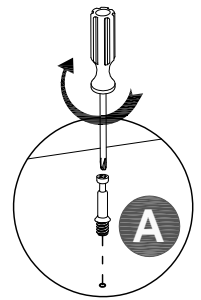
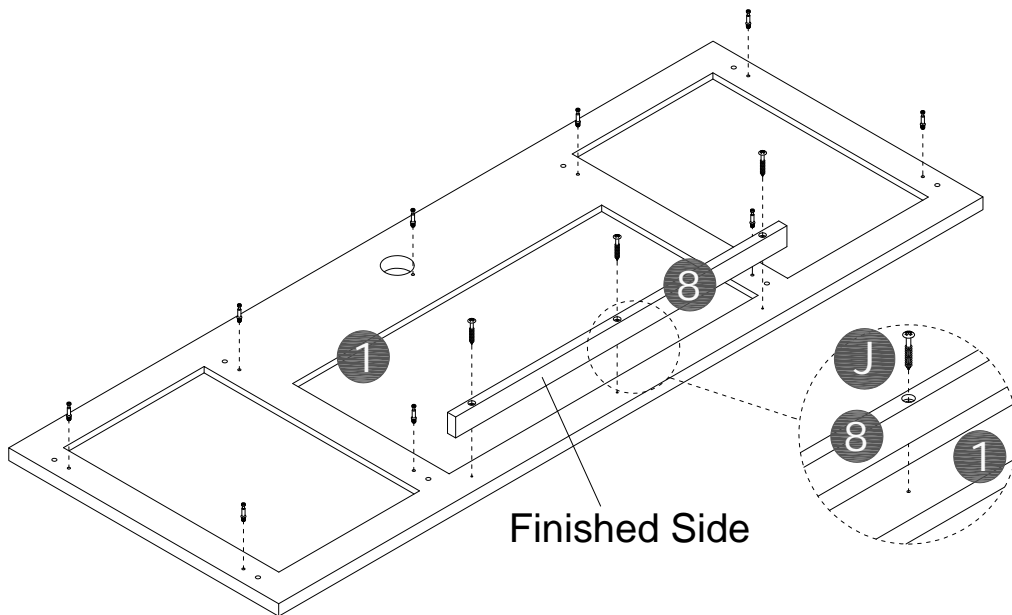

## STEP 17

**B** x 9pcs

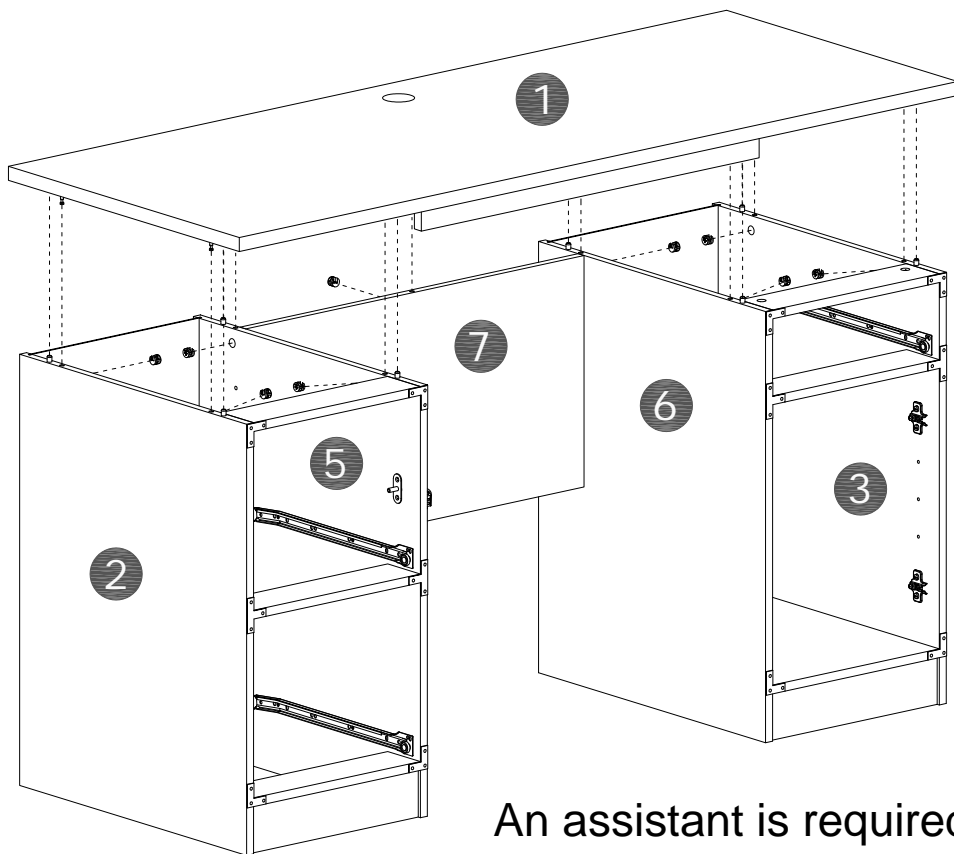
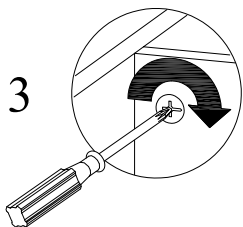
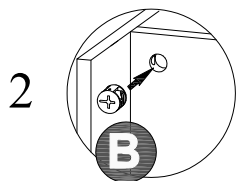
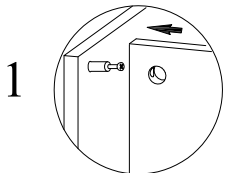

An assistant is required.

## STEP 18

**R** x 8pcs

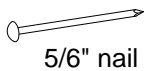

5/6" nail

**S** x 4pcs

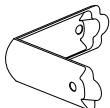

**U**

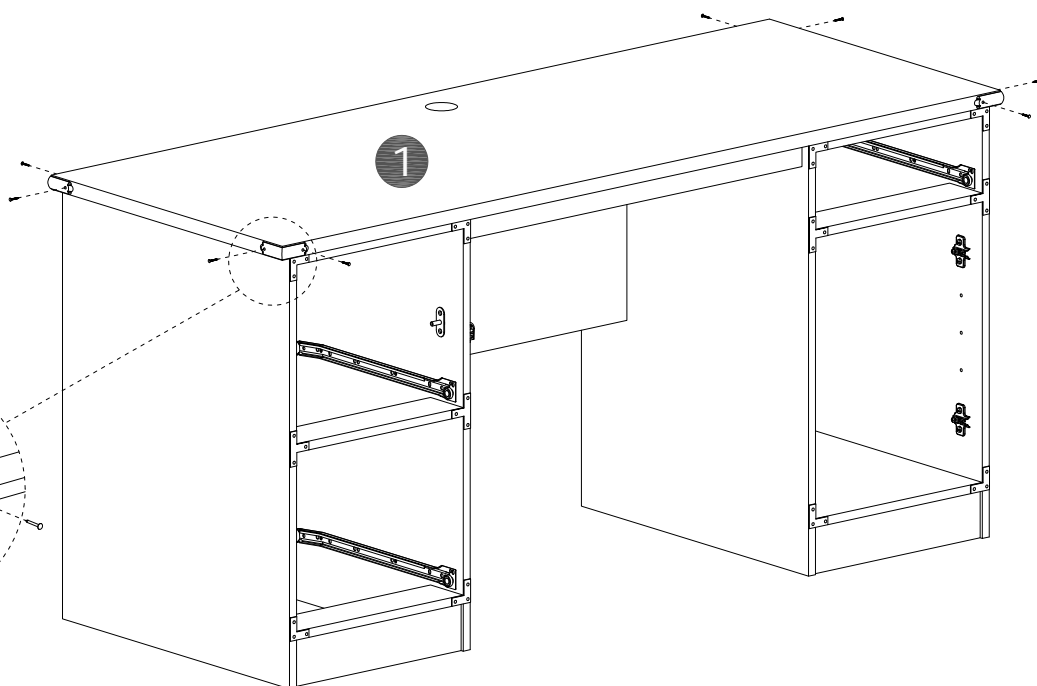
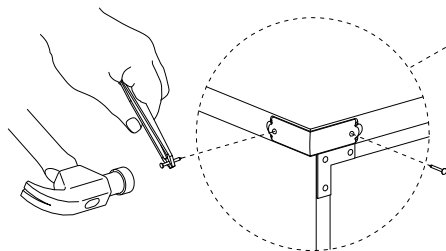
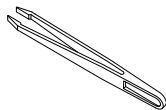

# STEP 19

AA x 4pcs 

T x 1pc 

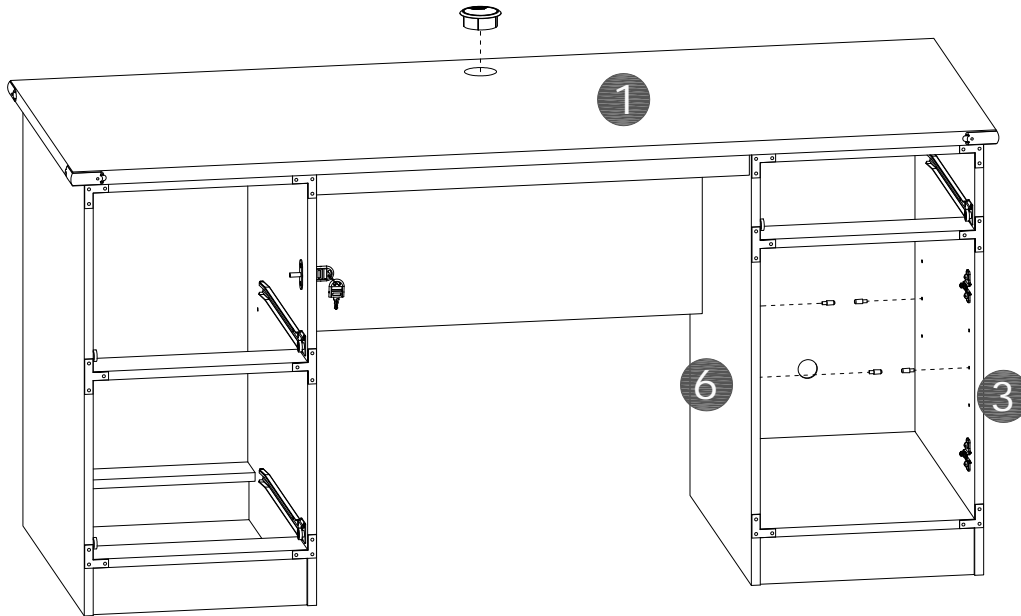

# STEP 20

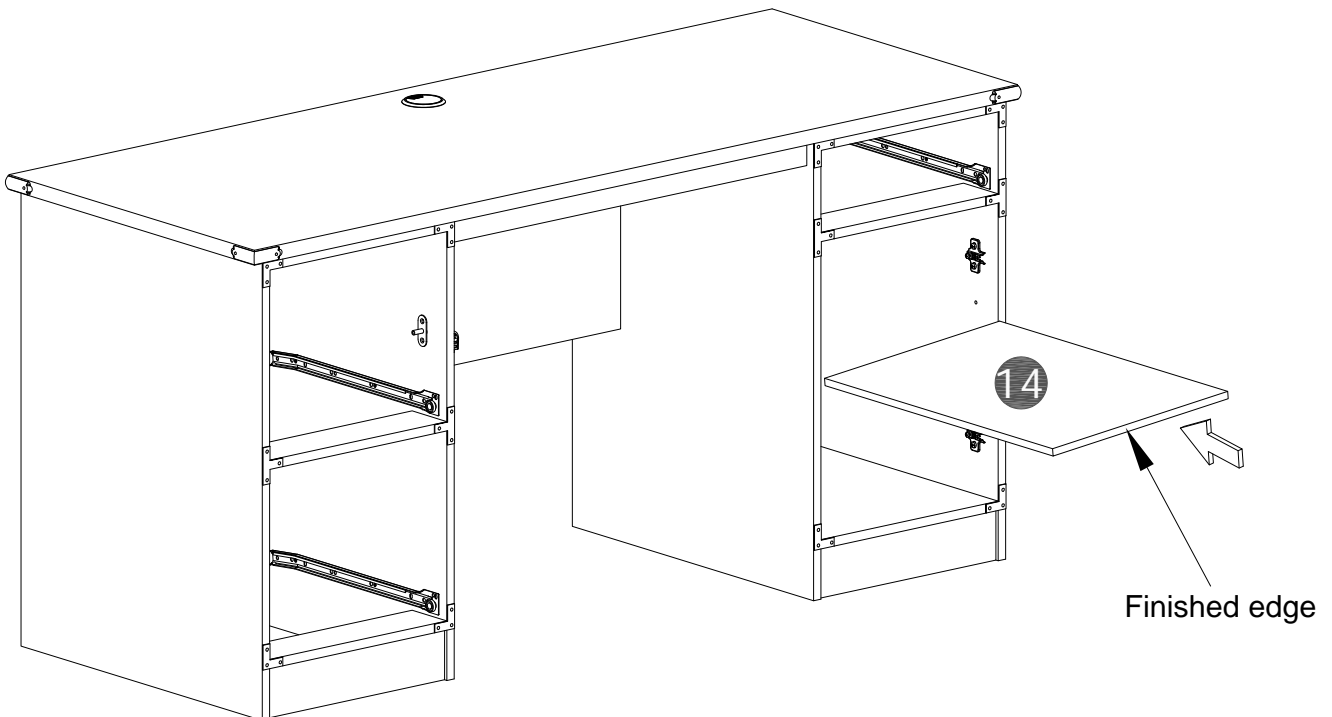

# STEP 21

**D** x 2pcs

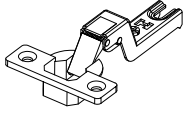

**Z** x 4pcs



**F** x 1pc



**G** x 2pcs

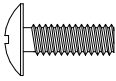

## WARNING

Caution, Storing electronic equipment may result in equipment overheating. Shelves located behind doors are not intended for storing electronic equipment. Placing electronic equipment in this area may result in equipment overheating

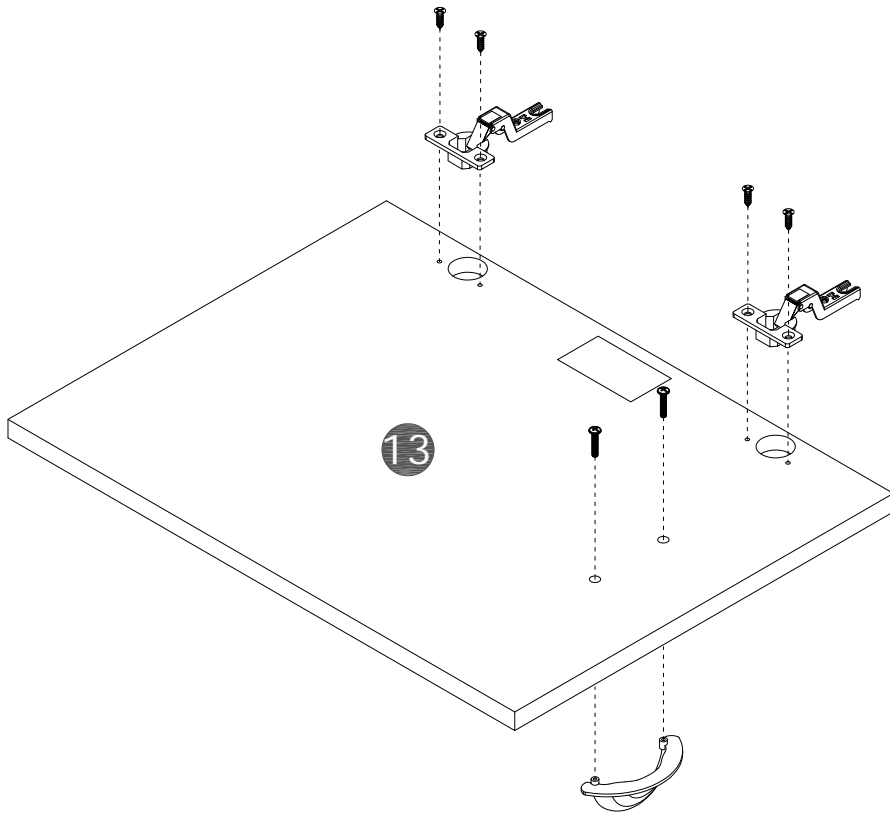

# STEP 22

## Installation

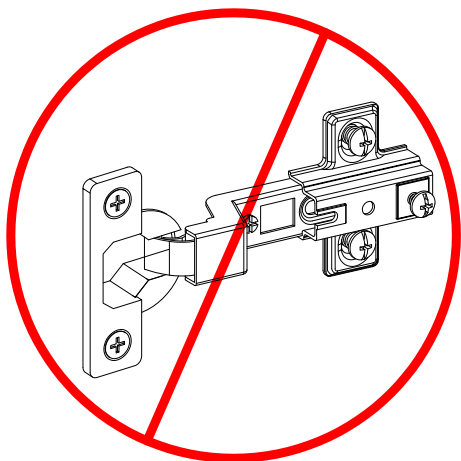
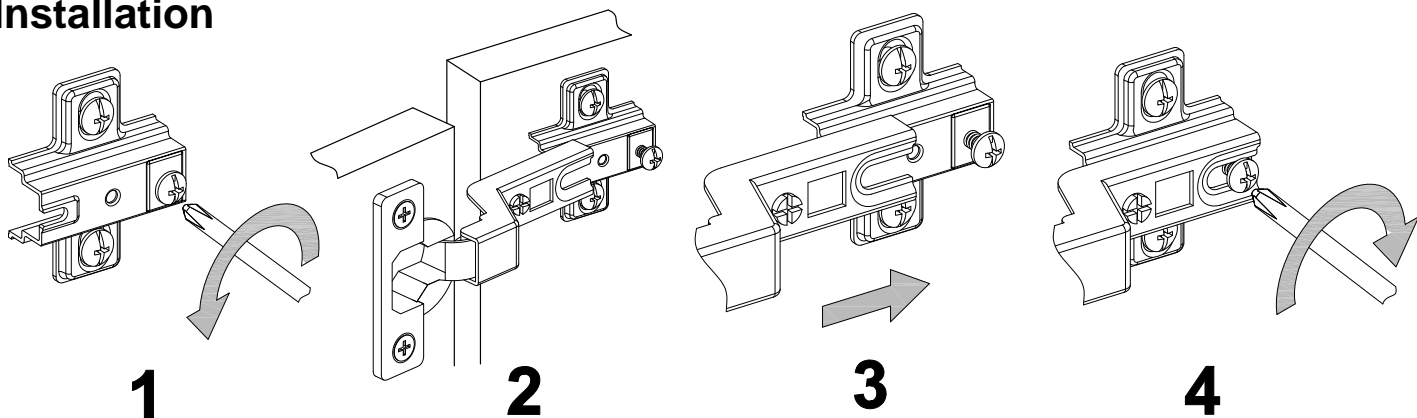

**DO NOT Insert  
Hinge beneath mount**

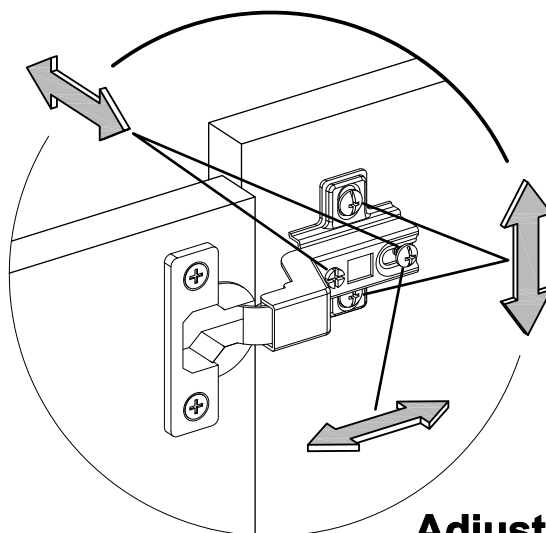

**Adjustment**

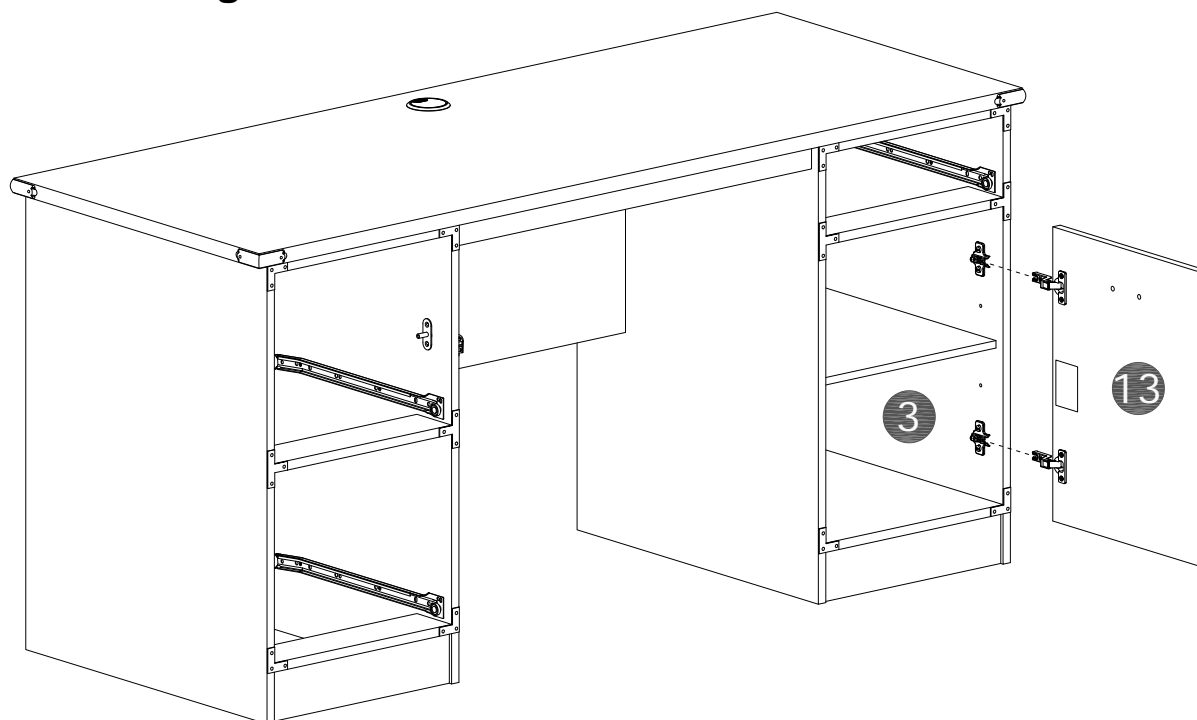

# STEP 23

- Move unit to final location.
- Adjust drawer fronts as shown below.

Step1--Loosen screws on back of drawer front brackets as shown.

Step2--Position drawer front as required.

Step3--Tighten screws while holding drawer front in position.

DRAWER FRONT VIEW

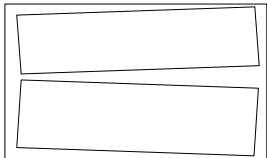
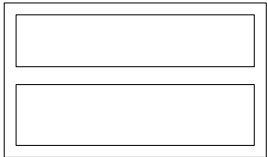

LOCKED



UNLOCKED

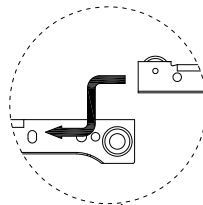
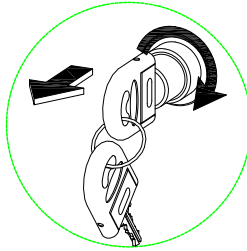

STEP 1.

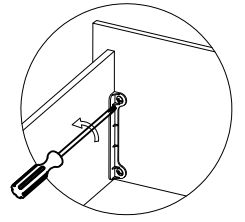

STEP 2.

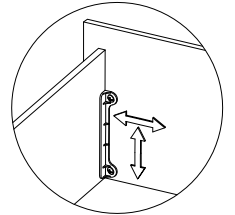

STEP 3.

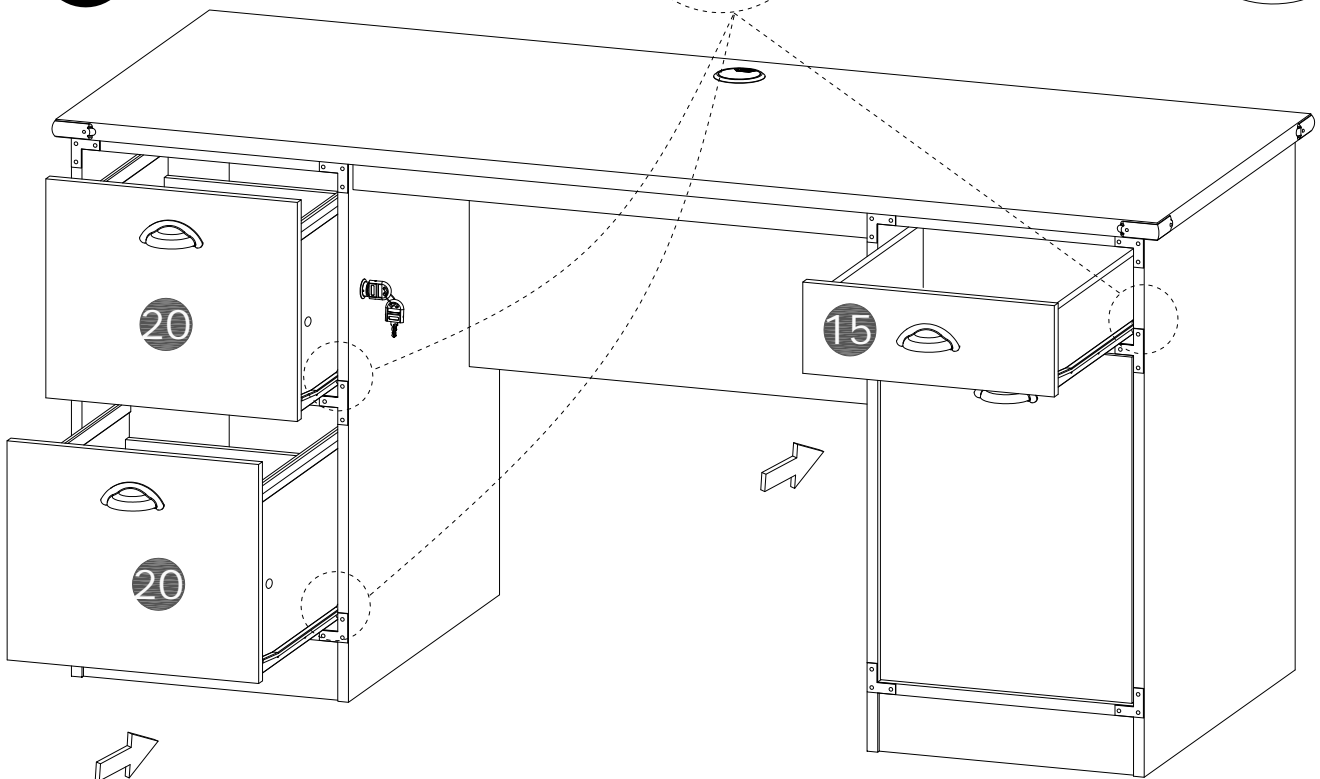
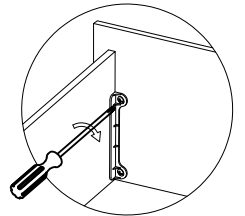

# Maximum weight capacities

