

NOTICE

- * Please make sure that you have all parts indicated and they are in good condition before you begin assembly of this item. Refer to part list and hardware list below for guidance.
- * This item should be assembled on a soft surface to prevent scratching the finish during assembly.
- * This item may require periodic tightening.
- * If you are having difficulty, our friendly Customer Care team is always here to help.

PREPARATION

- * Before beginning assembly of product, make sure all parts are present. Compare parts with part contents list and hardware contents list.
- * If any part is missing or damaged, do not attempt to assemble the product.
- * Estimated Assembly Time: 10 minutes.
- * Tools Required for Assembly (included): Allen Key

CARE AND MAINTENANCE

Always use felt pads under all articles to prevent discoloration or softening of the lacquer. Plastic and rubber bases on items can discolor wood. Wipe up spills immediately and avoid common hazards such as hot dishes, harsh solvents, and abrasives. Cleaning should be done with a soft lint free cotton cloth dampened with water.

Part List and Hardware List

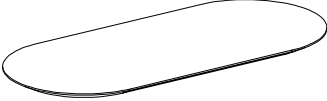
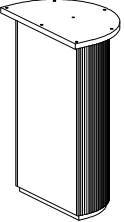
PIECE	DESCRIPTION	PICTURE	QUANTITY	CARTON CALL
A	TABLE TOP		1X	1 of 2
B	LEG FRAME		2X	2 of 2

Product Demensions: 78 3/4"W x 35 3/8" D x 29 1/2"H

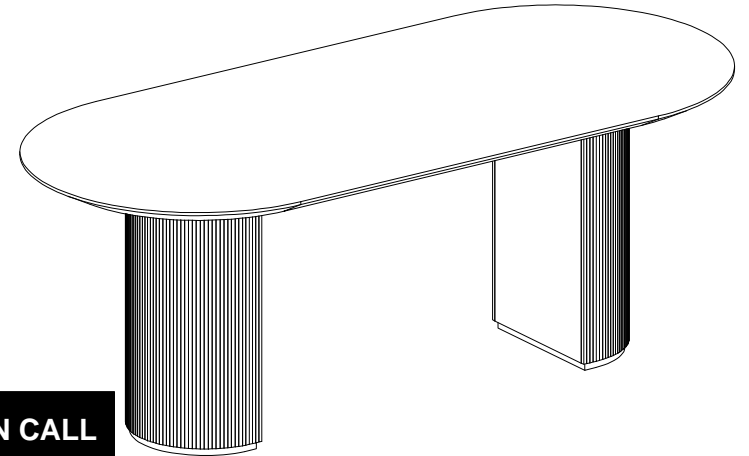

▲ WARNING ▲

Weight capacity - 74 LBS
 Warning: Do not stand on Table
 Warning: Do not over torque bolts

HW1	Dowel: Ø8X30 mm		2X	1 of 2
HW2	Bolt: M8x1.25x40 mm		12X	1 of 2
HW3	Split Lock Washer: M8		12X	1 of 2
HW4	Flat Washer: M8x20 mm		12X	1 of 2
HW5	Allen key		1X	1 of 2

PREPARATION

- * Before beginning assembly of product, make sure all parts are present. Compare parts with part contents list and hardware contents list.
- * If any part is missing or damaged, do not attempt to assemble the product.
- * Estimated Assembly Time: 10 minutes.
- * Tools Required for Assembly (included): Allen Key
- * If you are having difficulty, our friendly Customer Care team is always here to help.

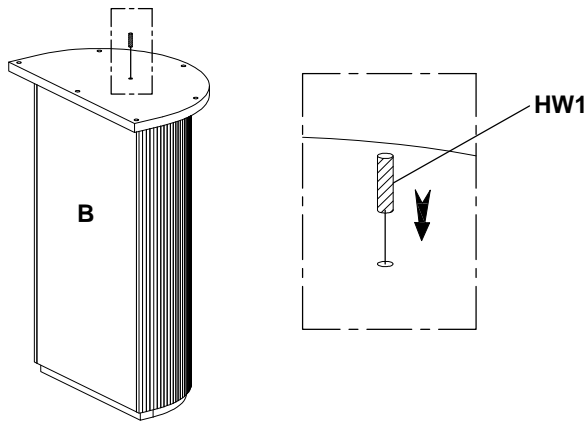
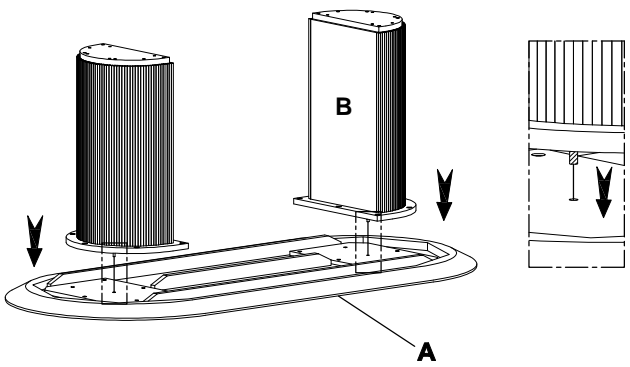
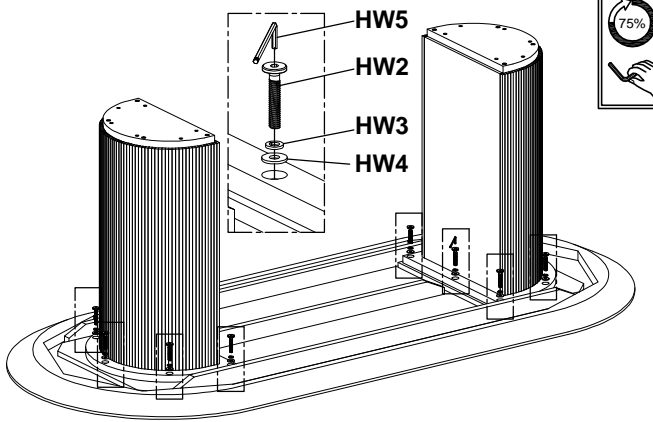
		
<p>STEP1: PLACE THE DOWEL (HW1) INTO THE WHOLE ON THE LEG FRAME (B).</p>	<p>STEP2: USING A SECOND PERSON TO ASSIST YOU, PLACE THE TABLE TOP (A) UPSIDE DOWN ON A CLEAN, SCRATCH FREE SURFACE. ALIGN THE LEG FRAMES (B) WITH THE CORRESPONDING HOLES ON THE TABLE TOP (A).</p>	<p>STEP3: ATTACH THE TABLE TOP (A) TO THE LEG FRAMES (B) BY USING THE ALLEN KEY (HW5) TO SCREW IN THE ALLEN BOLT (HW2) INTO THE SPLIT LOCK WASHER (HW3), THEN THE FLAT WASHER (HW4,) THEN THE TABLE TOP, AS SHOWN. DO NOT FULLY TIGHTEN THE BOLTS YET.</p>

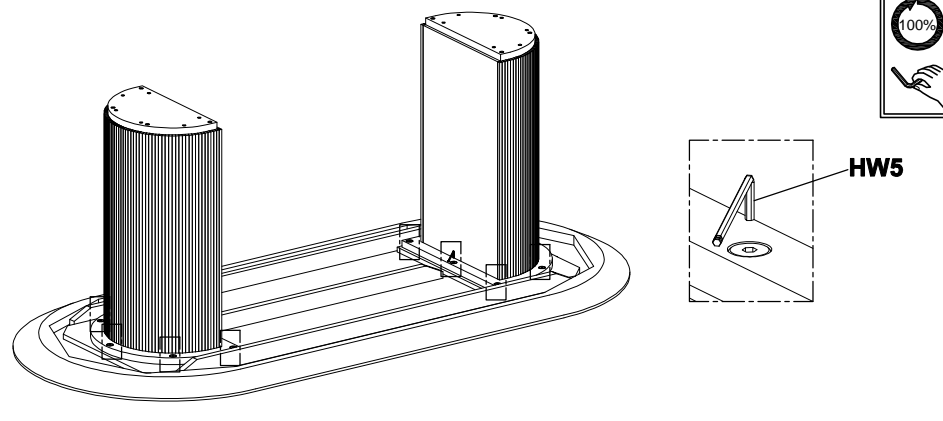
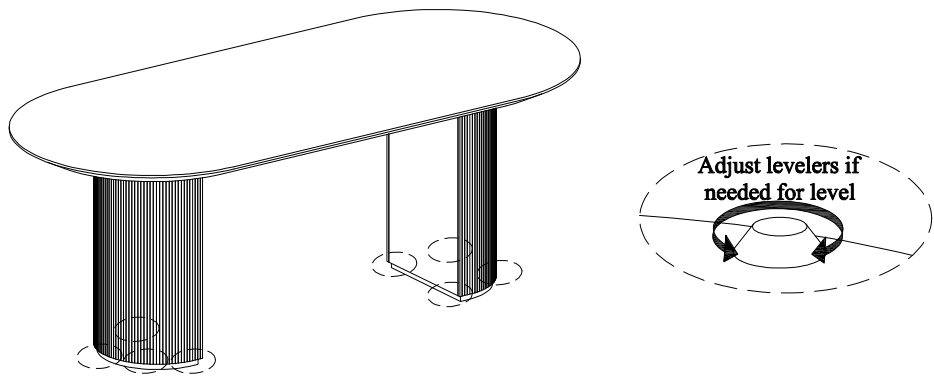
	
<p>STEP4: ONCE ALL HARDWARE HAS BEEN MOSTLY SCREWED IN, THEN USE THE ALLEN KEY (HW5) TO COMPLETELY SCREW IN THE ALLEN BOLTS (HW2).</p>	<p>STEP5: USING A SECOND PERSON TO ASSIST YOU, CAREFULLY TURN THE ASSEMBLED TABLE UPRIGHT.</p>