

ASSEMBLY INSTRUCTIONS

TOOLS REQUIRED



Allen Wrench

(Included)



Phillips
Screwdriver

(Not Included)

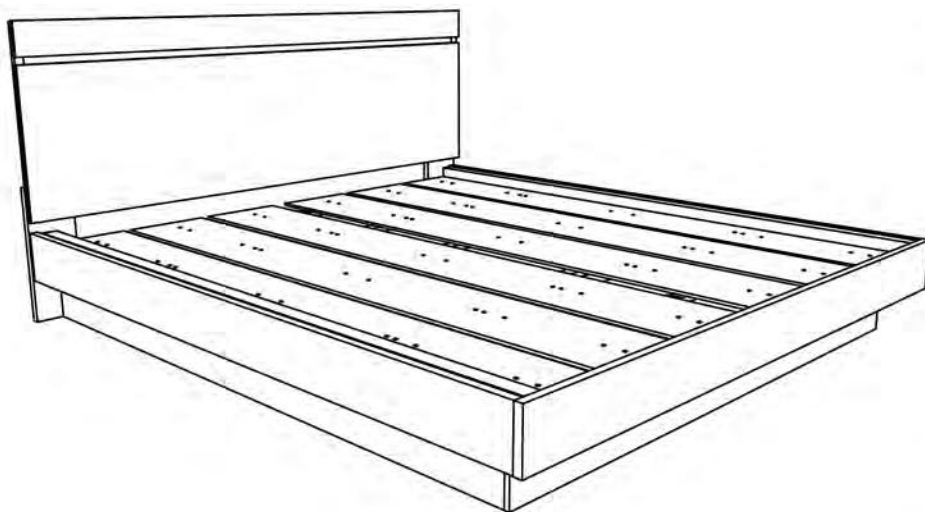

**3 - People
Recommended**

ASSEMBLY RATING



EASY —————> DIFFICULT

The Assembly Rating is a 5-point system showing the level of effort needed to assemble a specific product.



CHECK BEFORE STARTING

Are you missing anything?

Double-check all parts, hardware and accessories listed are all accounted for.

Check out our Quick Tips!

We recommend reviewing the pre-assembly handouts. Even experts need a refresher now and then!

Should we send any replacements?

Are there any irregularities or flaws in the parts? We can send replacements!

Prep Time!

Please review the assembly instructions and all diagrams prior to assembling.

PRE ASSEMBLY INTRODUCTION

We understand building ready-to-assemble furniture can be a challenging experience for some. To help avoid confusion, we have provided some helpful tips that may speed up the process.



Teamwork

ALWAYS have at least two people to help with transporting and assembling the product to avoid potential injury and/or damage.



Suitable Location

Assembling near the area of the intended location is highly recommended.



Sufficient Space

Make sure you have enough space to move around during the assembly.



Avoid Scratches

Use cardboard, blankets or a carpeted area while assembling furniture to prevent to prevent scratches and damages.



Flat Surface

Make sure the furniture rests on a flat and level surface with each leg evenly touching the floor.

ASSEMBLY AND CARE ADVICE



FAILURE TO FOLLOW THE GUIDELINES BELOW MAY RESULT IN INJURY AND/OR PROPERTY DAMAGE.



Position each part correctly and insert screws or bolts into their respective holes.



Turn clockwise to tighten and only tighten when step is completed or when instructed to do so.



Use the appropriate hand tools or power tools for assembly. Select steps, such as tightening screws and/or bolts, may require hand tools to avoid causing damage during assembly.



Save the instructions and store any supplied tools for later maintenance.



After two weeks, check and tighten any loose hardware and repeat again every six months thereafter.

IT IS THE USER'S RESPONSIBILITY TO MAINTAIN THE FURNITURE. THE HARDWARE MAY LOOSEN OVER TIME AND MAY CAUSE THE FURNITURE TO BE WOBBLY AND UNABLE TO SUPPORT ITS INTENDED WEIGHT CAPACITY. THIS MAY LEAD TO COLLAPSE AND MAY CAUSE SERIOUS INJURY.







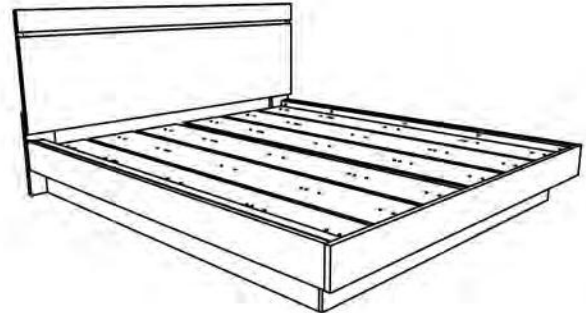



CALIFORNIA KING SIZE BED



- Please keep instructions for future reference.
- Check the quantity and irregularity of parts and hardware before you start.







PARTS





#1 1pc  Headboard	#2 2pcs  Headboard Leg L&R	#3 1pc  Footboard	#4 2pcs  Side Rail	#5 2pcs  Platform Rail
#6 2pcs  Bed Slat with Marking -1951 x 45 x 18mm	#7 3pcs  Bed Slat without Marking -1951 x 45 x 18mm	#8 1pc  Platform Rail Support -1796 x 45 x 18mm	#9 10pcs  Bed Slat Support -225 x 30 x 30mm	
#10 6pcs  Concealed Panel -2164 x 295 x 9mm	#11 2pcs  Side Cap			

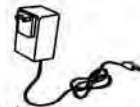



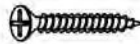

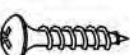

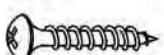









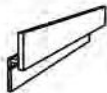



HARDWARE

HARDWARE INSIDE HEADBOARD

#A 1pc  Allen Key M4	#B 4pcs  Bolt 1/4" x 1-3/8"	#C 4pcs  Lock washer	#D 4pcs  Flat washer	#E 8pcs  CSK m4 x 32mm	#F 1pc  Adaptor
--	---	--	--	--	---

HARDWARE INSIDE SIDE RAIL

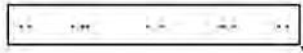
#G 12pcs  CSK m4 x 32mm	#H 10pcs  Bolt 1/4" x 2"	#I 30pcs  Pan Head Screw m3.5 x 20mm	#J 1pc  Allen Key M4	#K 1pc  Allen Key M5	#L 10pcs  Pan Head Screw m4 x 45mm
---	--	---	--	--	---

Carton	Designation	Part		Hardware
	King Size Bed HB	#1		 #A x 1pc  #B x 4pcs  #C x 4pcs  #D x 4pcs  #E x 8pcs  #F x 1pc
		#2	 X 2	
	King Size Bed FB	#3		
	Cali.King Size Bed Rails	#4	 X 2	 #G x 12pcs  #H x 10pcs  #I x 30pcs  #J x 1pc  #K x 1pc  #L x 10pcs
		#5	 X 2	
		#6	 X 2	
		#7	 X 3	
		#8		
		#9	 X 10	
		#10	 X 6	
		#11	 X 2	

ASSEMBLY INSTRUCTIONS

1

Align headboard legs (#2L/R) to the headboard (#1). Secure using bolts (#B) with washers (#C,D) and screws (#E) as shown in the diagrams.

- Part #1 x1pc
- Part #2 x2pcs
- Hardware #B x4pcs
- Hardware #C x4pcs
- Hardware #D x4pcs
- Hardware #E x8pcs

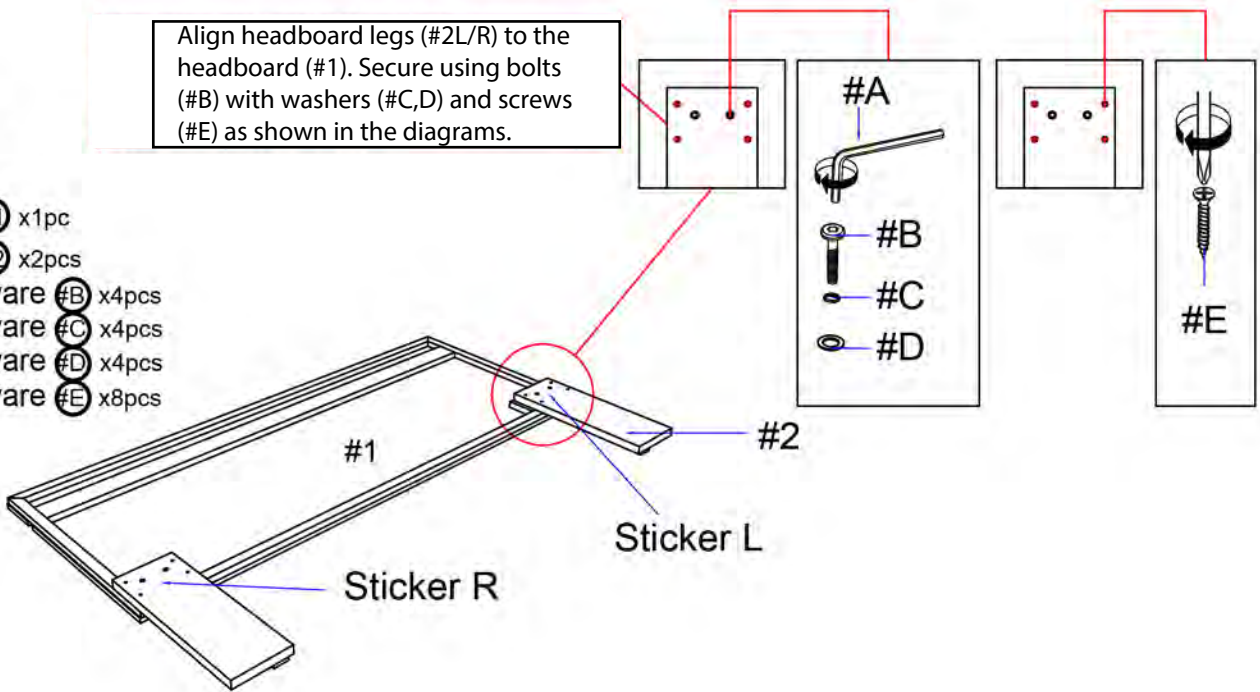

2

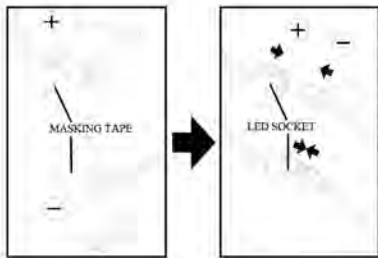

CAUTION !!!
PLEASE
CONNECT THE
LED TERMINAL
SOCKET
AFTER FIT IN THE
HOOK PART
AS SHOWN.

PLEASE REMOVE MASKING TAPE
BEFORE CONNECT

1. Align and hook side rails (#4,5) to the headboard legs (#2L/R) and footboard (#3). Tighten bolts to secure in place.

- Part #3 x1pc
- Part #4 x2pcs
- Part #5 x2pcs
- Part #8 x1pc
- Hardware #G x2pcs

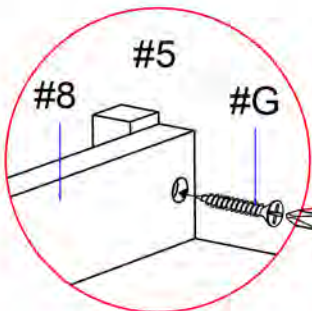
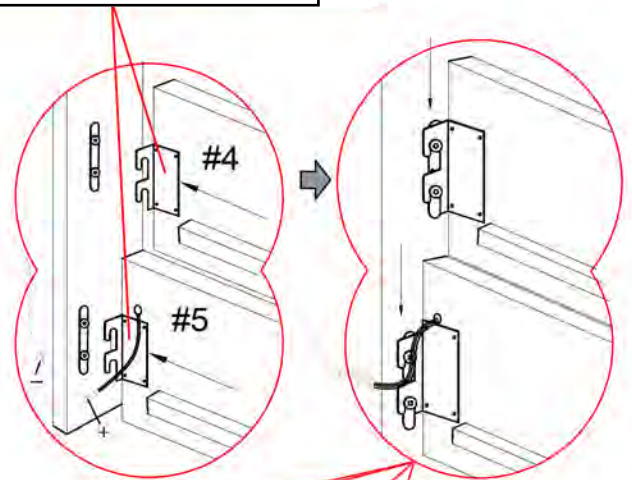

2. Align and secure platform rail support (#8) to the platform rail (#5) by using screws (#G).

ASSEMBLY INSTRUCTIONS

3

- Part #6 x2pcs
- Part #7 x3pcs
- Part #9 x10pcs
- Hardware #H x10pcs

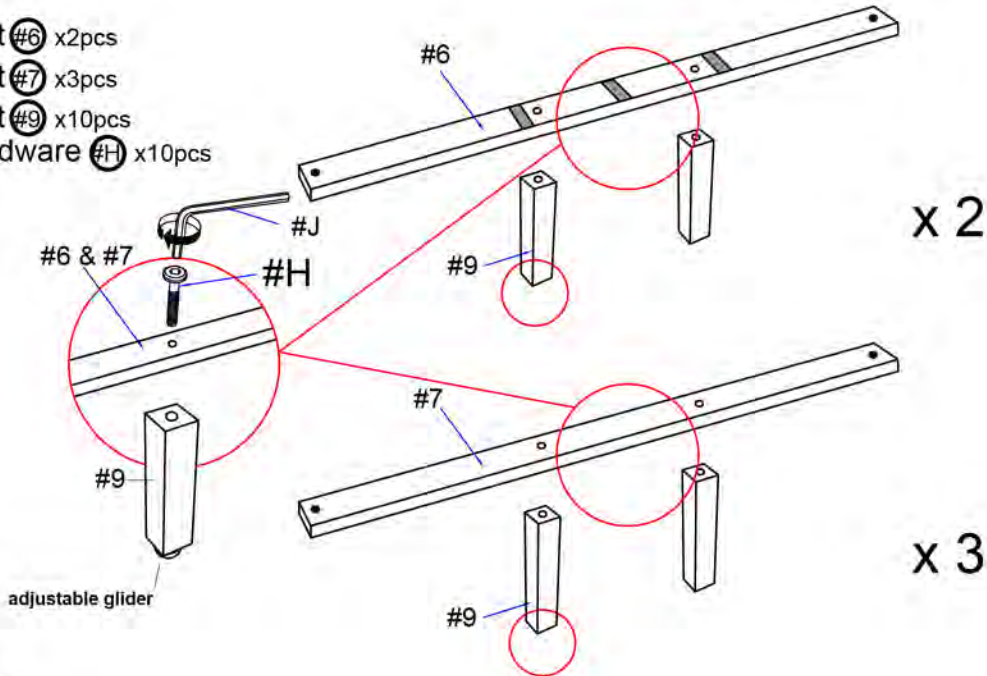

4

- Hardware #G x10pcs

Align slats (#6,7) evenly to the side rails, then secure using screws (#G) as shown in the diagram.

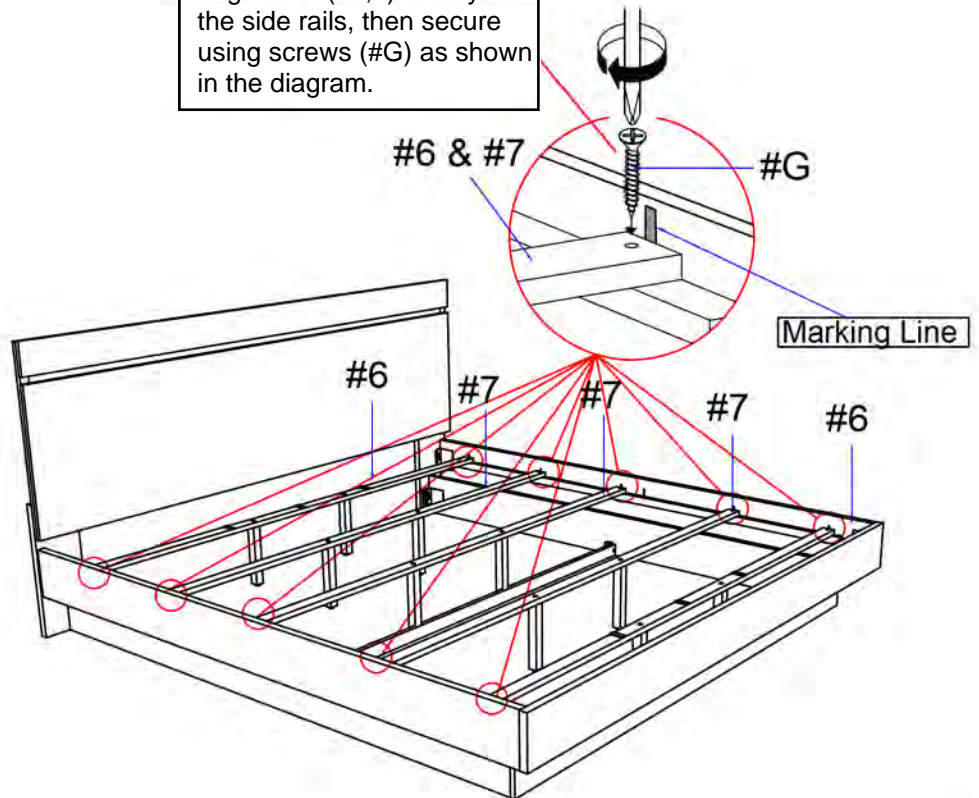

ASSEMBLY INSTRUCTIONS

5

- Part #10 x6pcs
- Part #11 x2pcs
- Hardware #F x1pc
- Hardware #1 x30pcs
- Hardware #L x10pcs

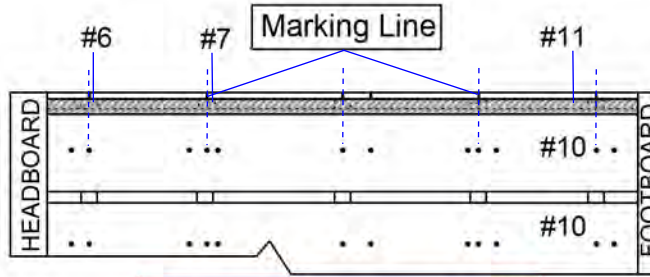

This is how the concealed panel (#10,#11) look like on the bed from a high view.

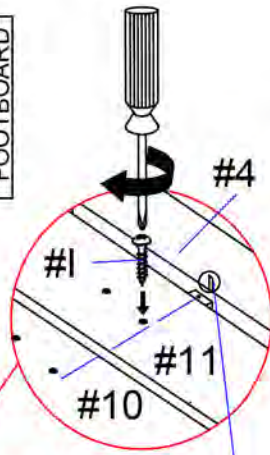

Attach adaptor (#C).

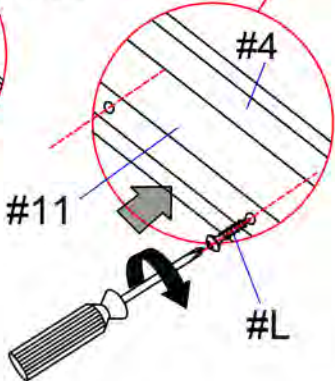
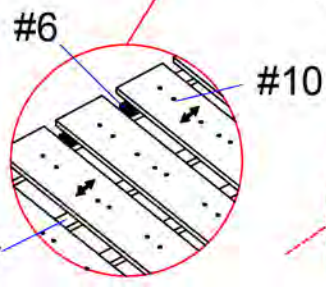
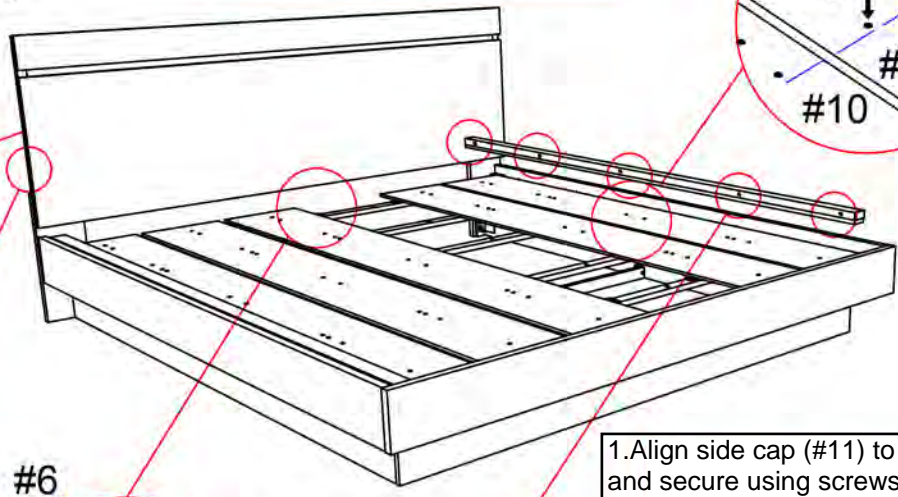
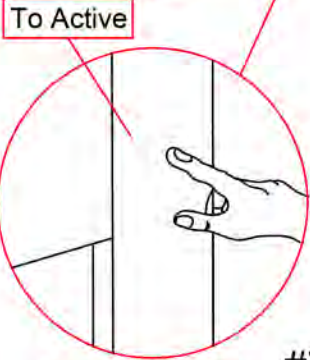
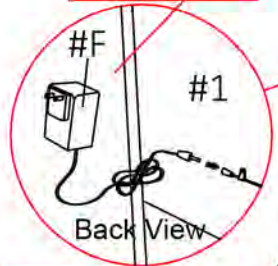

- 1.Align side cap (#11) to the side rails (#4) and secure using screws (#L).
- 2.Please refer to step (#5) on how to align and place concealed panels (#10,11) correctly.
- 3.Secure the concealed panels (#10) to the bed slats (#6,7) by using screws(#1).

ASSEMBLY COMPLETED

Please ensure the furniture rests on an even and flat surface. If the product wobbles or feels loose, double-check all bolts and/or screws are properly tightened and secured.

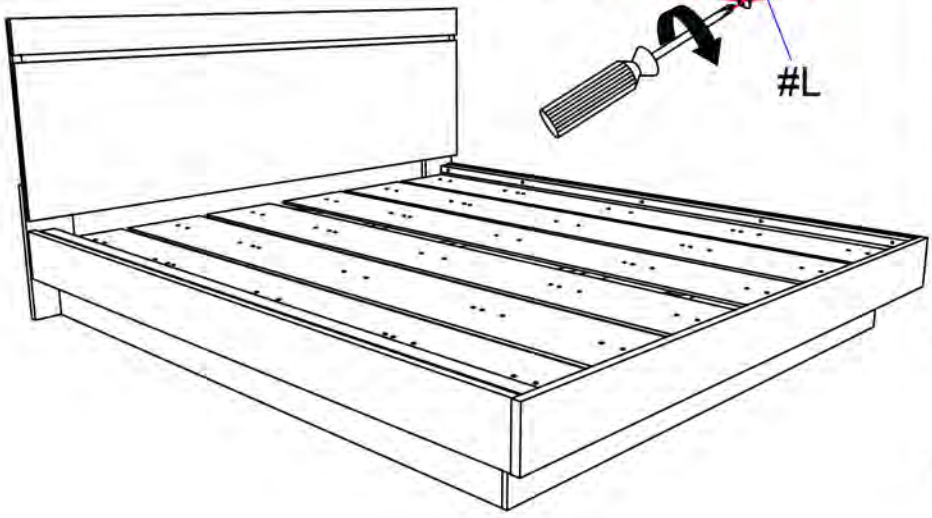

- Keep this handy!**
 Please retain this instruction manual and any order-related information for future reference.
- Lift, don't drag!**
 To avoid damage to product please always LIFT the product when transporting or adjusting the placement.

ASSEMBLY INSTRUCTIONS

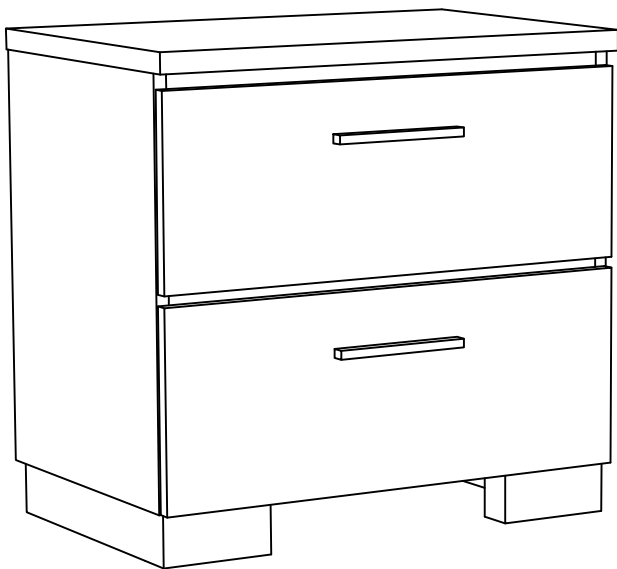

TOOLS REQUIRED



**Philips
Screwdriver**

(Not Included)



**2 - People
Recommended**

ASSEMBLY RATING



EASY —————> DIFFICULT

The Assembly Rating is a 5-point system showing the level of effort needed to assemble a specific product.



CHECK BEFORE STARTING

Are you missing anything?

Double-check all parts, hardware and accessories listed on Page 6 are accounted for.

Check out our Quick Tips!

We recommend reviewing the pre-assembly handouts. Even experts need a refresher now and then!

Should we send any replacements?

Are there any irregularities or flaws in the parts? We can send replacements!

Prep Time!

Please review the assembly instructions and all diagrams prior to assembling. Arrange parts as recommended on Page 7 and group identical hardware together to make assembling easier.

PRE ASSEMBLY INTRODUCTION

We understand building ready-to-assemble furniture can be a challenging experience for some. To help avoid confusion, we have provided some helpful tips that may speed up the process.

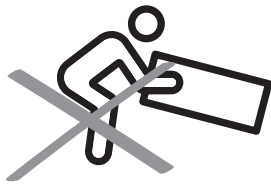

Teamwork

ALWAYS have at least two people to help with transporting and assembling the product to avoid potential injury and/or damage.

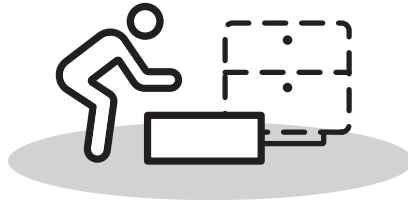
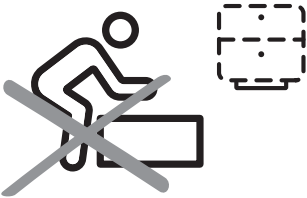

Suitable Location

Assembling near the area of the intended location is highly recommended.



Sufficient Space

Make sure you have enough space to move around during the assembly.



Avoid Scratches

Use cardboard, blankets or a carpeted area while assembling furniture to prevent scratches.

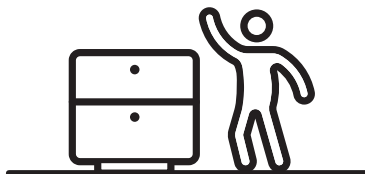
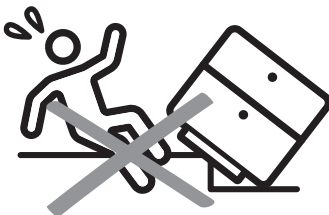

Flat Surface

Make sure the furniture rests on a flat and level surface with each leg evenly touching the floor.

ASSEMBLY AND CARE ADVICE



FAILURE TO FOLLOW THE GUIDELINES BELOW MAY RESULT IN INJURY AND/OR PROPERTY DAMAGE.



Position each part correctly and insert screws or bolts into their respective holes.

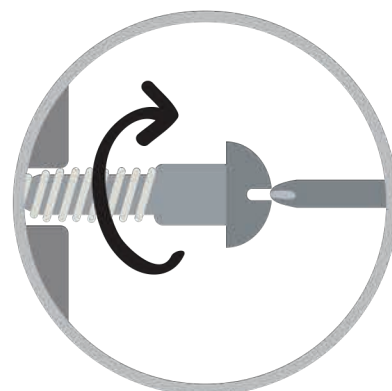

Turn clockwise to tighten and only tighten when step is completed or when instructed to do so.



Use the appropriate hand tools or power tools for assembly. Select steps, such as tightening screws and/or bolts, may require hand tools to avoid causing damage during assembly.

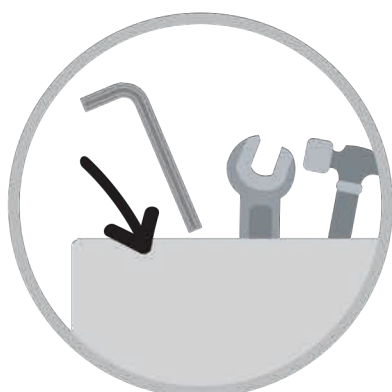

Save the instructions and store any supplied tools for later maintenance.

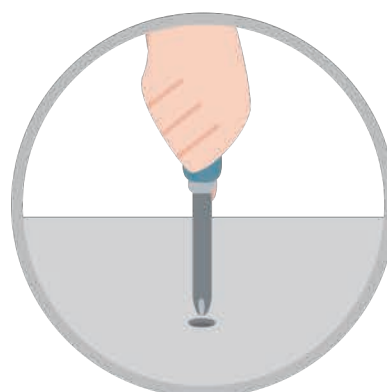

After two weeks, check and tighten any loose hardware and repeat again every six months thereafter.

IT IS THE USER'S RESPONSIBILITY TO MAINTAIN THE FURNITURE. THE HARDWARE MAY LOOSEN OVER TIME AND MAY CAUSE THE FURNITURE TO BE WOBBLY AND UNABLE TO SUPPORT ITS INTENDED WEIGHT CAPACITY. THIS MAY LEAD TO COLLAPSE AND MAY CAUSE SERIOUS INJURY.

NIGHTSTAND



- Please keep instructions for future reference.
- Check the quantity and irregularity of parts and hardware before you start.

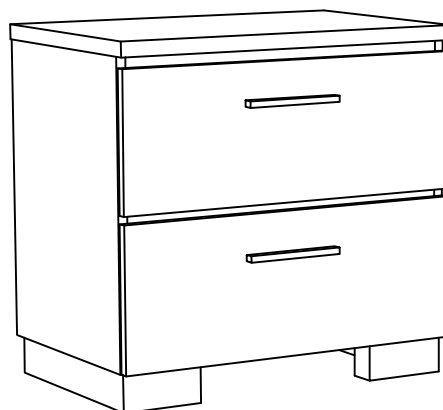

PARTS

#1 1pc



Nightstand

HARDWARE

#A 2pcs



Csk Screw
m3 x 20mm

#B 1pc



USB Port

ASSEMBLY INSTRUCTIONS

Attach USB ports to the desired location of the nightstand (#1)

1

Part #1 x1pc

Hardware #A x2pcs

Hardware #B x1pc

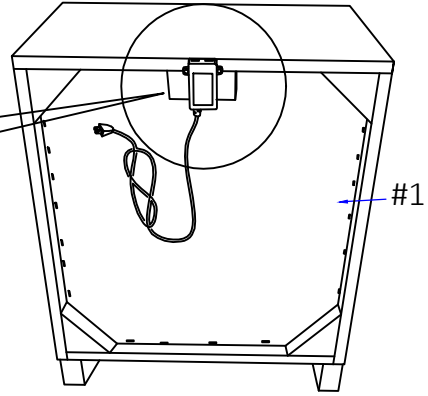
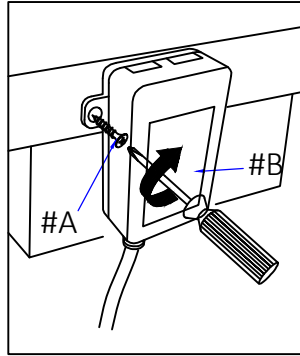

REMARK :
The USB assembly position on customer desires.

BACK VIEW

2

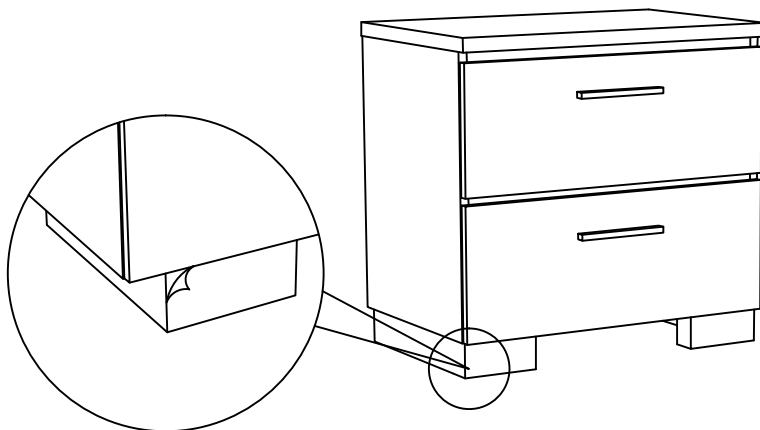

PLEASE REMOVE THE PROTECTIVE FILM
BEFORE USE

ASSEMBLY COMPLETED



Please ensure the furniture rests on an even and flat surface. If the product wobbles or feels loose, double-check all bolts and/or screws are properly tightened and secured.



Keep this handy!

Please retain this instruction manual and any order-related information for future reference.



Lift, don't drag!

To avoid damage to product please always LIFT the product when transporting or adjusting the placement.

ASSEMBLY INSTRUCTIONS

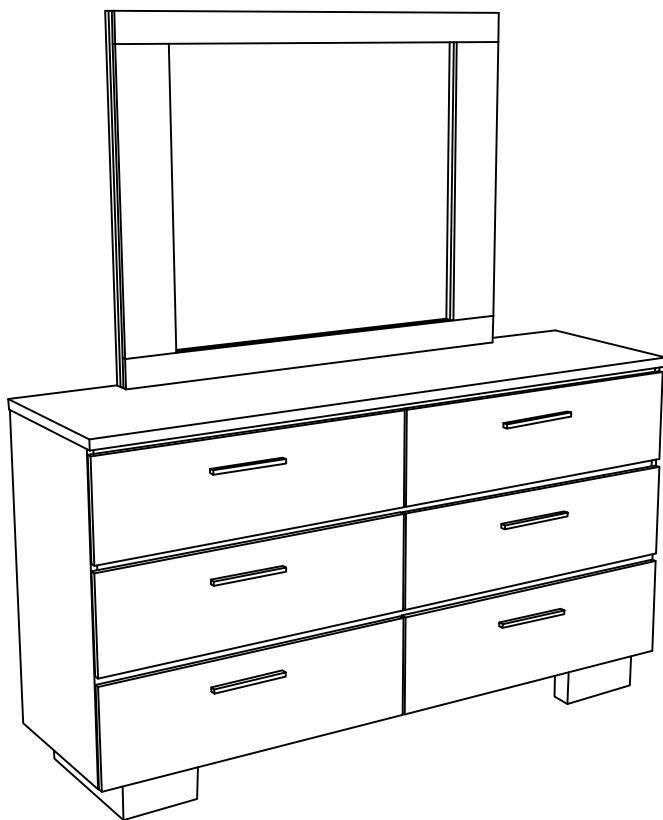

TOOLS REQUIRED



Allen Wrench

(Included)



**Philips
Screwdriver**

(Not Included)



**2 - People
Recommended**

ASSEMBLY RATING



EASY —————> DIFFICULT

The Assembly Rating is a 5-point system showing the level of effort needed to assemble a specific product.



CHECK BEFORE STARTING

Are you missing anything?

Double-check all parts, hardware and accessories listed on Page 6 are accounted for.

Check out our Quick Tips!

We recommend reviewing the pre-assembly handouts. Even experts need a refresher now and then!

Should we send any replacements?

Are there any irregularities or flaws in the parts? We can send replacements!

Prep Time!

Please review the assembly instructions and all diagrams prior to assembling. Arrange parts as recommended on Page 7 and group identical hardware together to make assembling easier.

PRE ASSEMBLY INTRODUCTION

We understand building ready-to-assemble furniture can be a challenging experience for some. To help avoid confusion, we have provided some helpful tips that may speed up the process.

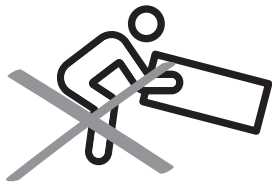

Teamwork

ALWAYS have at least two people to help with transporting and assembling the product to avoid potential injury and/or damage.

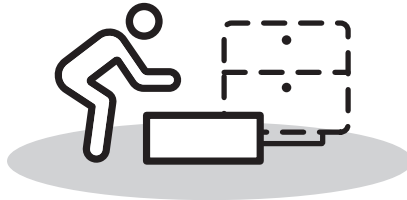
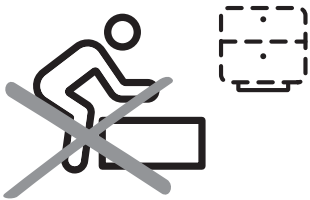

Suitable Location

Assembling near the area of the intended location is highly recommended.



Sufficient Space

Make sure you have enough space to move around during the assembly.



Avoid Scratches

Use cardboard, blankets or a carpeted area while assembling furniture to prevent scratches.

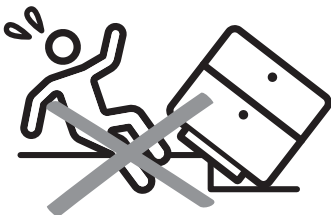

Flat Surface

Make sure the furniture rests on a flat and level surface with each leg evenly touching the floor.

ASSEMBLY AND CARE ADVICE



FAILURE TO FOLLOW THE GUIDELINES BELOW MAY RESULT IN INJURY AND/OR PROPERTY DAMAGE.



Position each part correctly and insert screws or bolts into their respective holes.

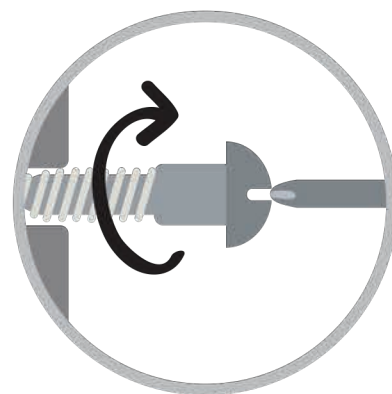

Turn clockwise to tighten and only tighten when step is completed or when instructed to do so.



Use the appropriate hand tools or power tools for assembly. Select steps, such as tightening screws and/or bolts, may require hand tools to avoid causing damage during assembly.



Save the instructions and store any supplied tools for later maintenance.

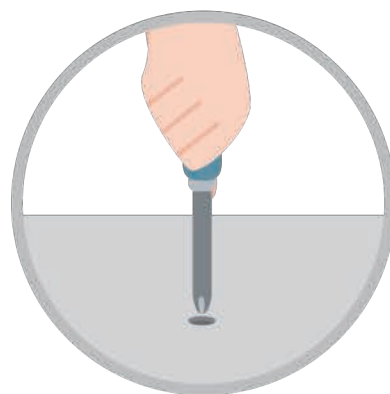

After two weeks, check and tighten any loose hardware and repeat again every six months thereafter.

IT IS THE USER'S RESPONSIBILITY TO MAINTAIN THE FURNITURE. THE HARDWARE MAY LOOSEN OVER TIME AND MAY CAUSE THE FURNITURE TO BE WOBBLY AND UNABLE TO SUPPORT ITS INTENDED WEIGHT CAPACITY. THIS MAY LEAD TO COLLAPSE AND MAY CAUSE SERIOUS INJURY.

MIRROR/DRESSER

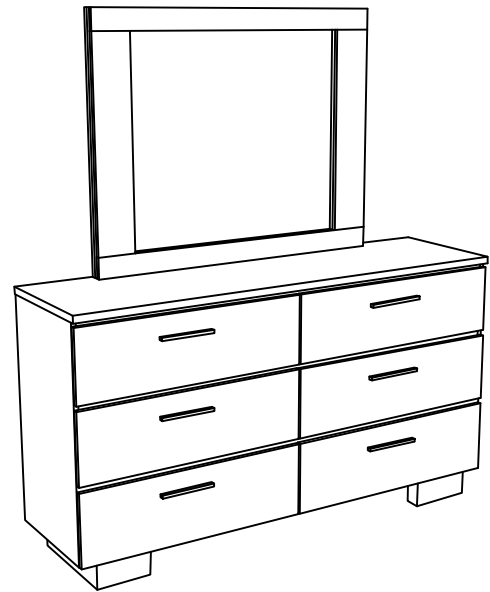
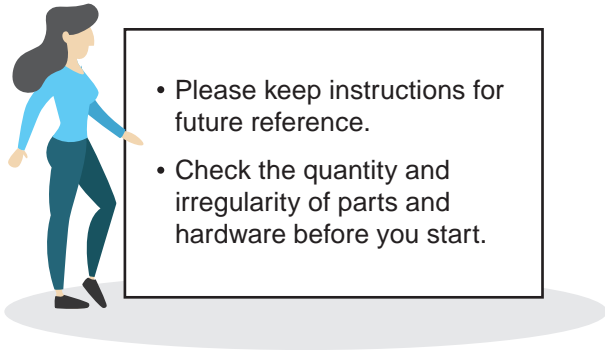

PARTS

#1 1pc

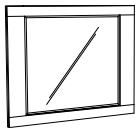

Mirror

#2 2pcs

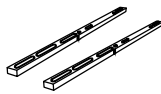

Mirror Support
18x30x890mm

#3 1pc



Dresser

HARDWARE

#A 4pcs

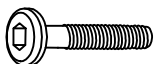

Bolt 1/4" x 1-3/8"

#B 4pcs

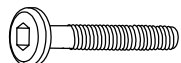

Bolt 1/4" x 1-1/2"

#C 8pcs



Lock washer

#D 8pcs



Flat washer

#E 1pc

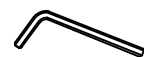

Allen Key M4

ASSEMBLY INSTRUCTIONS

Remove mirror supports from the box (#2).

1

- Part #1 x1pc
- Part #2 x2pcs

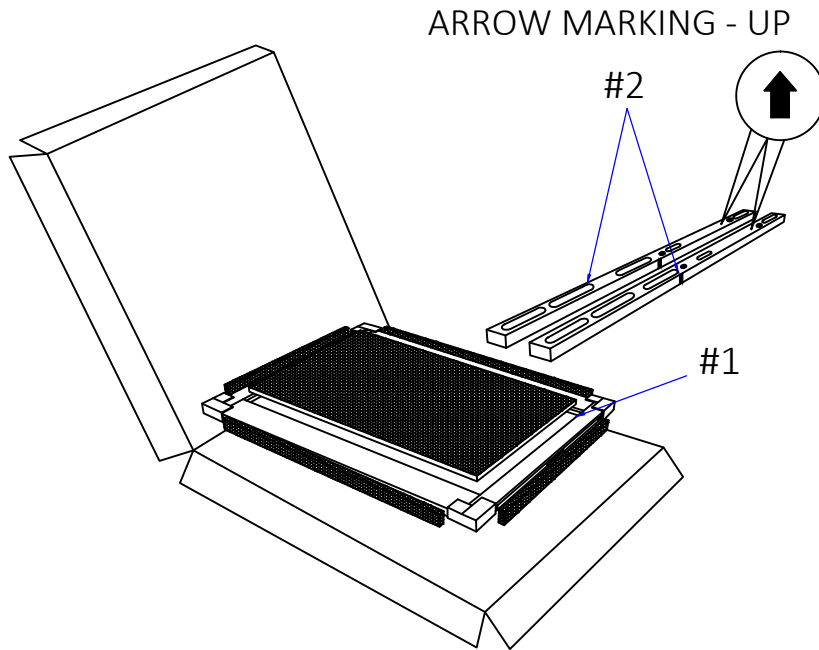

2

- Part #3 x1pc
- Hardware #A x4pcs
- Hardware #B x4pcs
- Hardware #C x8pcs
- Hardware #D x8pcs

Align mirror supports (#2) to the holes of the mirror (#1) and dresser (#3), then secure by using bolts (#A,B) with washers (#C,D).

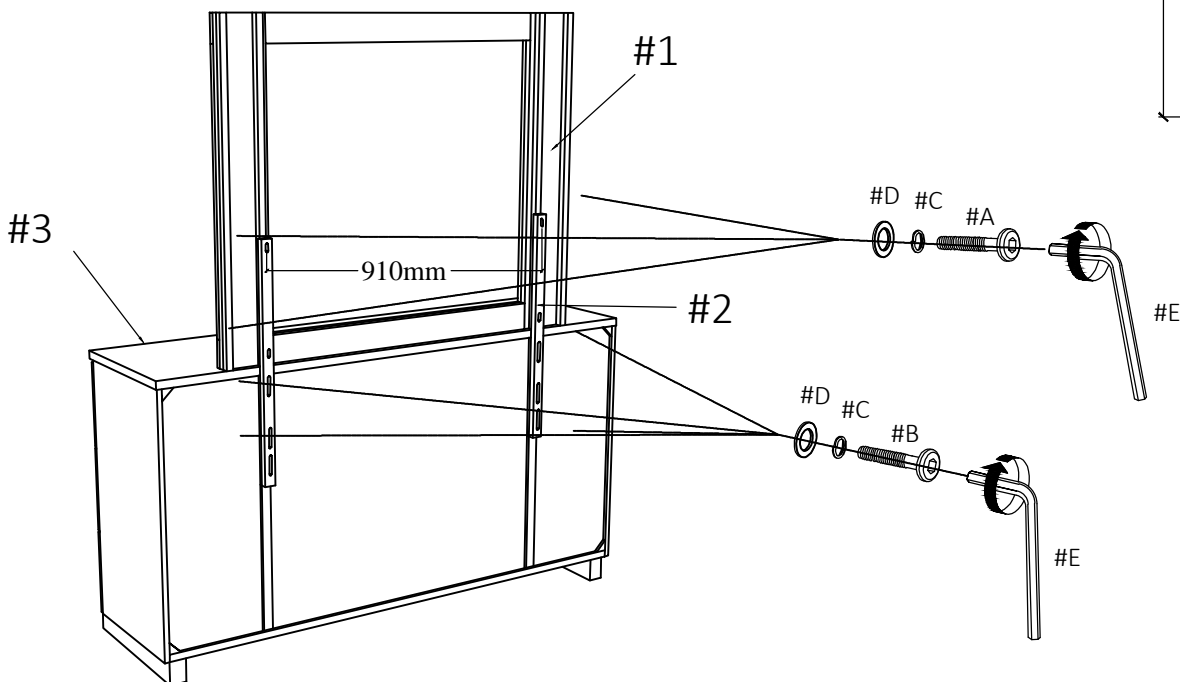
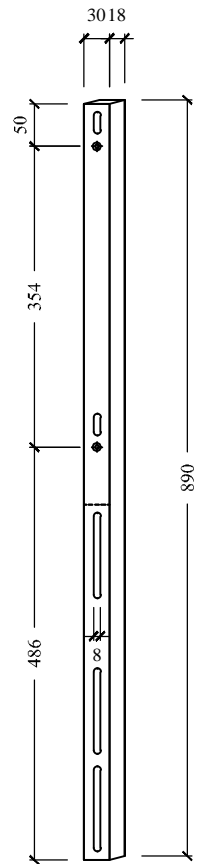

ASSEMBLY INSTRUCTIONS

3

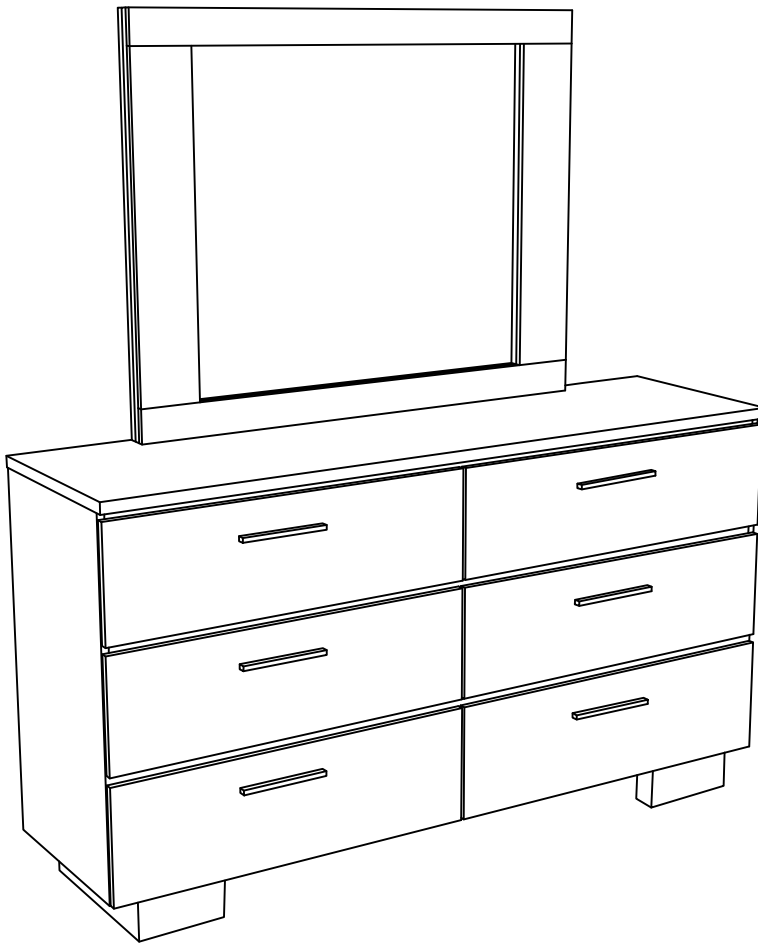

ASSEMBLY COMPLETED



Please ensure the furniture rests on an even and flat surface. If the product wobbles or feels loose, double-check all bolts and/or screws are properly tightened and secured.



Keep this handy!

Please retain this instruction manual and any order-related information for future reference.



Lift, don't drag!

To avoid damage to product please always LIFT the product when transporting or adjusting the placement.