

Assembly Instructions

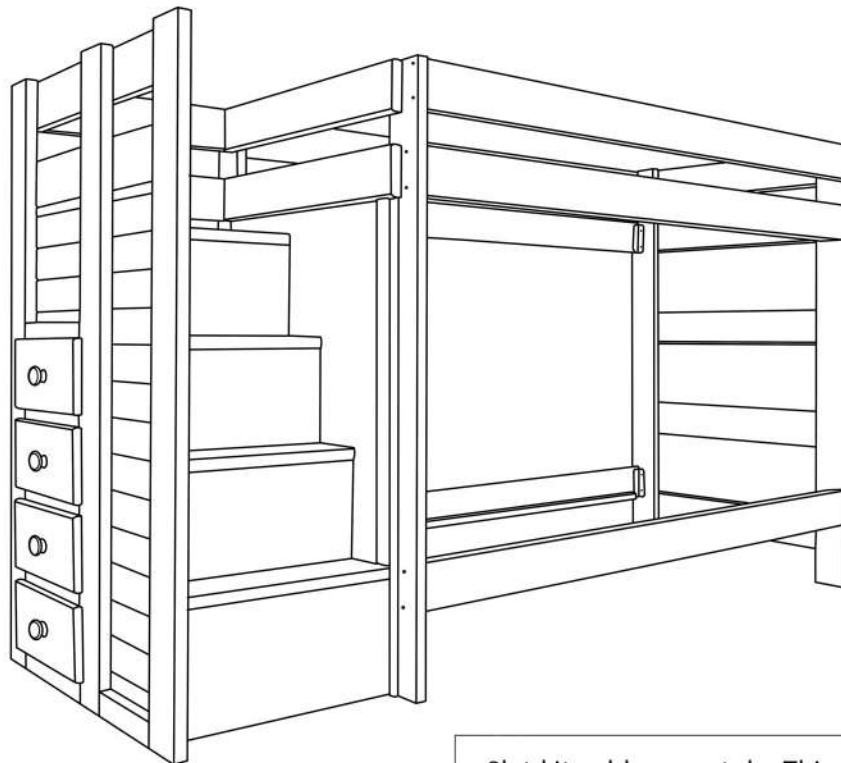

Slat kit sold separately. This product requires a bunkie board or a bunkie board combo mattress.

ASSEMBLY RATING

The Assembly Rating is a 5-point system that shows the degree of effort needed in assembling a specific product (with 1 being easy and 5 being difficult). For some products, two persons are recommended.

EASY  DIFFICULT

Tools Required For Assembly:

Allen Wrench



(Included)

Phillips Screwdriver



(Not Included)

Power Drill
(Recommended)



(Not Included)



2 Person Recommended

ASSEMBLY & CARE ADVICE

FOR YOUR FURNITURE TO LAST, CORRECT ASSEMBLY AND PROPER MAINTENANCE ARE NECESSARY. PLEASE FOLLOW THE INFORMATION PROVIDED BELOW TO FULLY ENJOY YOUR FURNITURE.

BASIC ASSEMBLY TECHNIQUES

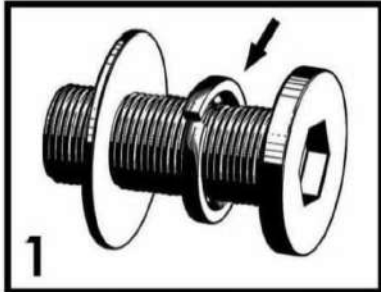

When lock or spring washer is used in an assembly, please make sure the lock or spring washer is placed between the larger flat washer and the head of the screw or bolt.



Position each part correctly and insert screws or bolts into their respective holes by hand tighten or using the proper hand tool. Only tighten when step is completed or when instructed to do so.

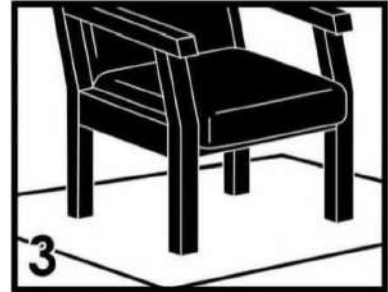

Use cardboard or carpet area when assembling furniture to prevent scratches. Make sure the furniture rests on a flat and level surface with each leg evenly touching the floor.

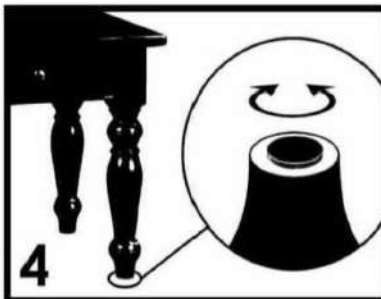

Some furniture comes with height adjustment knobs underneath each leg. To lower or to raise each leg, you need to turn clockwise or counterclockwise, respectively.

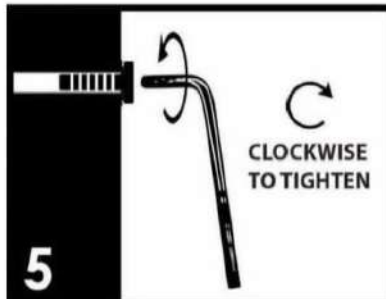

Make sure all parts are properly aligned, then use the appropriate hand tool to completely tighten the bolts or screws. Do not use power tools and do not overtighten.

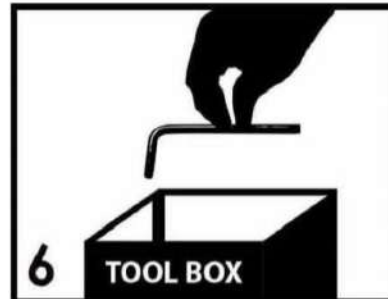

Save the instructions and store the Allen wrench or any supplied tool for later maintenance. After two weeks, check and tighten any loose hardware and repeat again every six months thereafter.

IT IS THE USER'S RESPONSIBILITY TO MAINTAIN THE FURNITURE. THE HARDWARE MAY LOOSEN OVER TIME AND MAY CAUSE THE FURNITURE TO BE WOBBLY AND UNABLE TO SUPPORT ITS INTENDED WEIGHT CAPACITY. THIS MAY LEAD TO COLLAPSE AND MAY CAUSE SERIOUS INJURY.



FAILURE TO FOLLOW THE GUIDELINES ABOVE MAY RESULT IN INJURY AND/OR PROPERTY DAMAGE.

PARTS



Box 1
Staircase Headboard x1

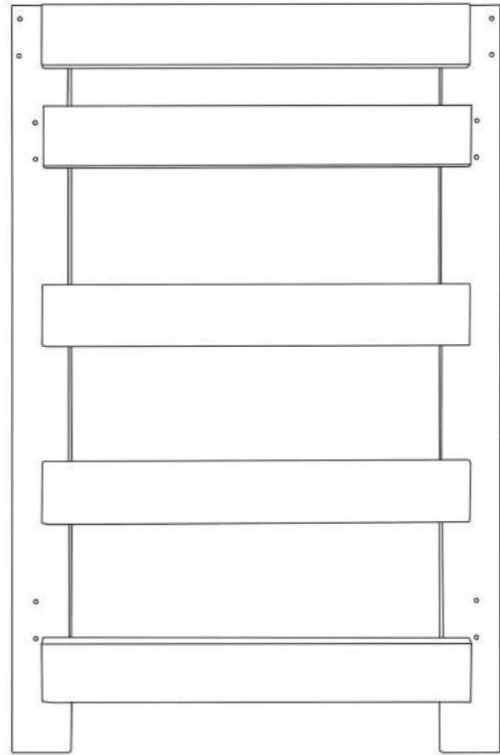

Box 2
Twin Footboard x1

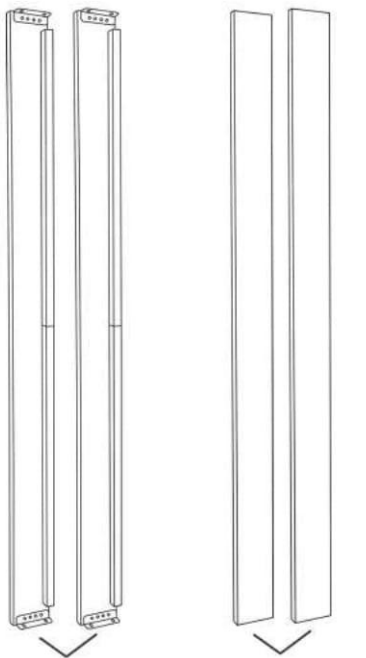

Side Rails x2 Guard Rails x2

Box 3
Twin Top Rails

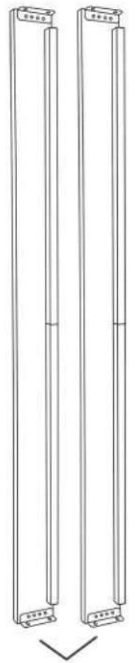

Side Rails x2

Box 4
Twin Bottom Rails x2

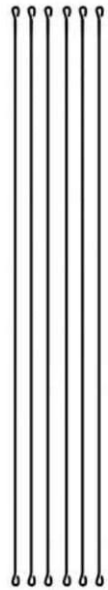

WIRES x6

HARDWARE

A  **Screw x12**

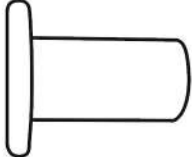
B  **Bolt x16**

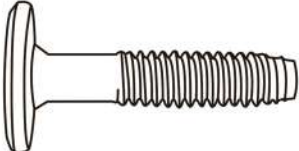
C  **Bolt x16**

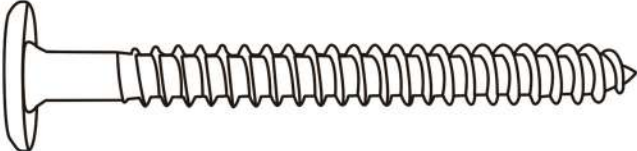
D  **Screw x8**

E  **Allen Wrench x1**

STEP 1

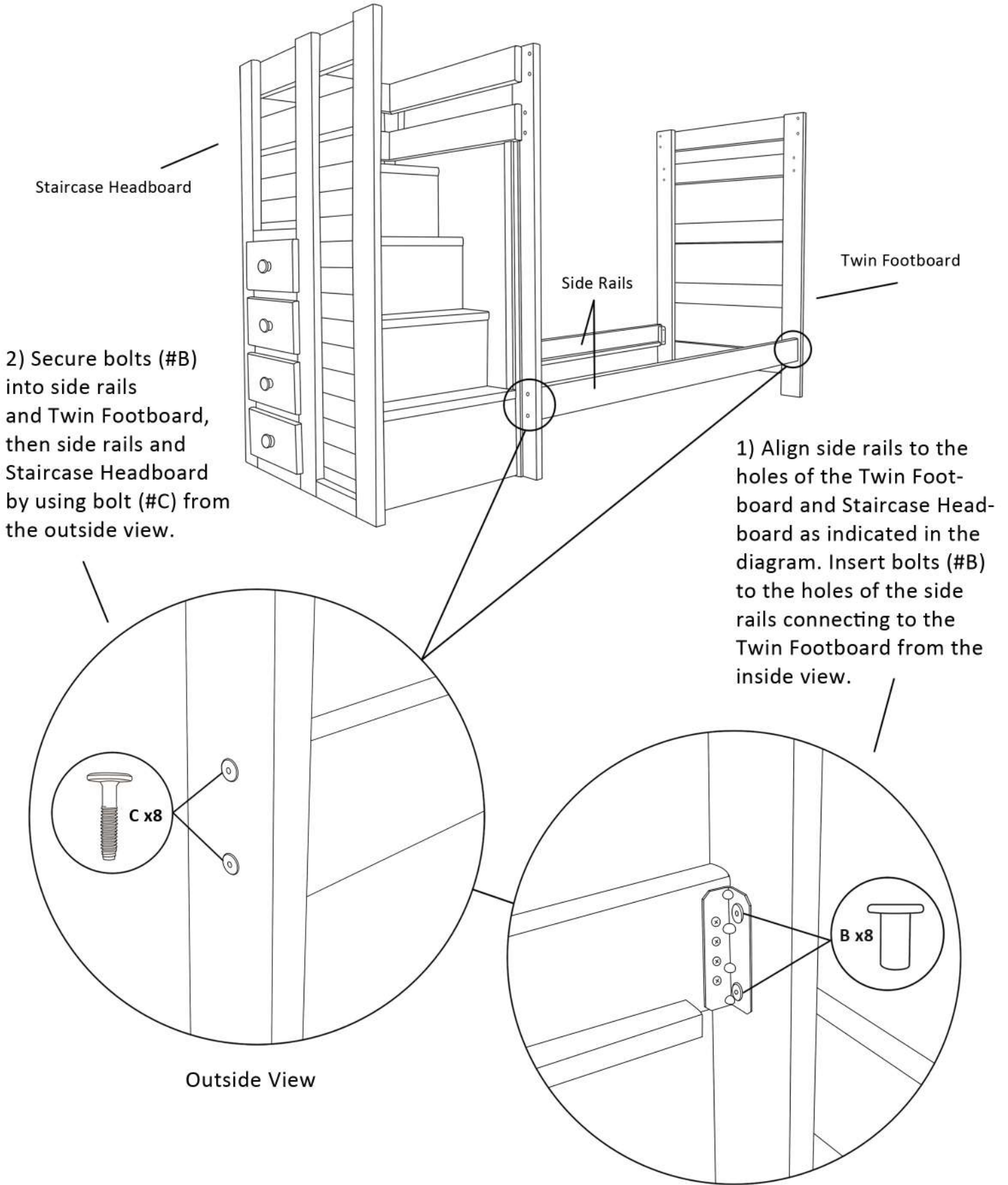

STEP 2

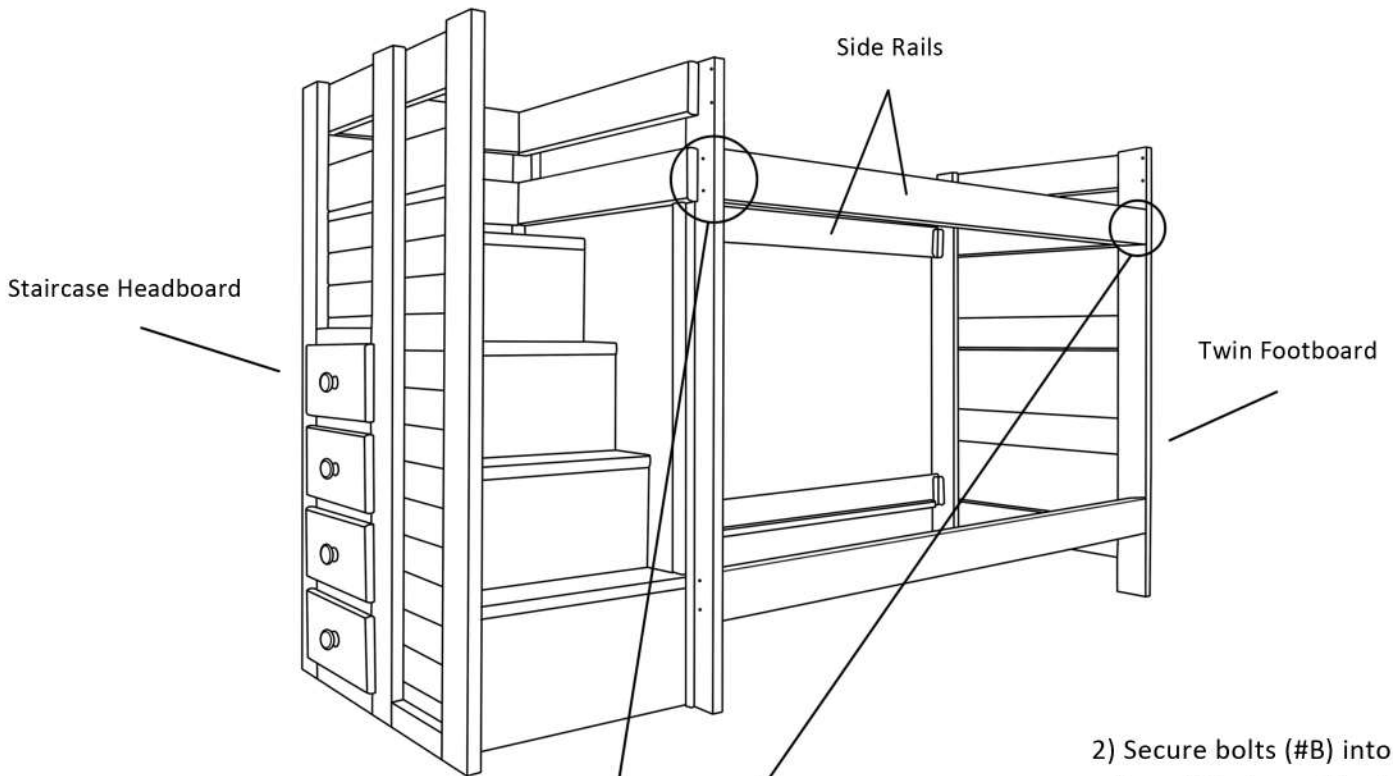

1) Align side rails to the holes of the Staircase Headboard and Twin Footboard as indicated in the diagram. Insert bolts (#B) to the holes of the side rails connecting to the Staircase Headboard

2) Secure bolts (#B) into side rails and Staircase Headboard, and Twin Footboard by using bolt (#C) from the outside view.

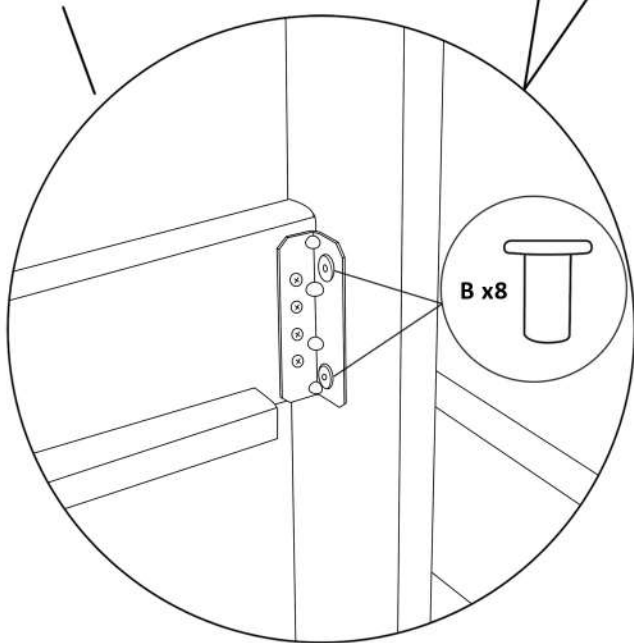

Inside View

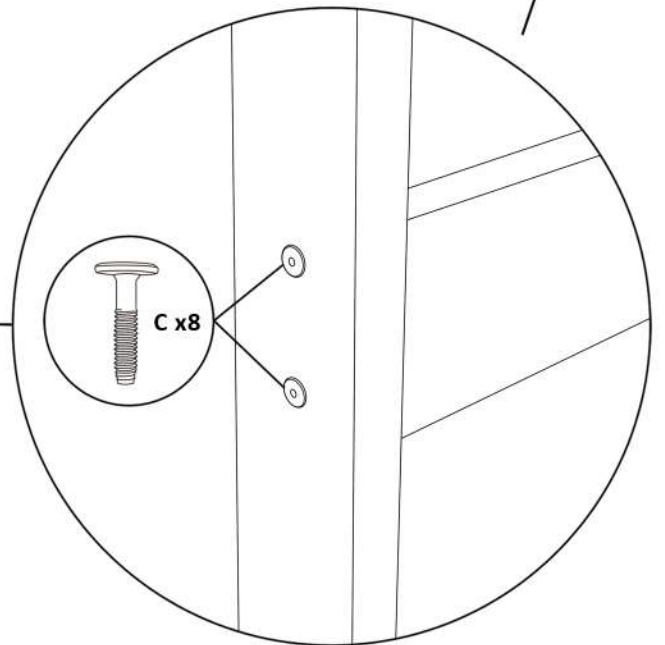

Outside View

STEP 3

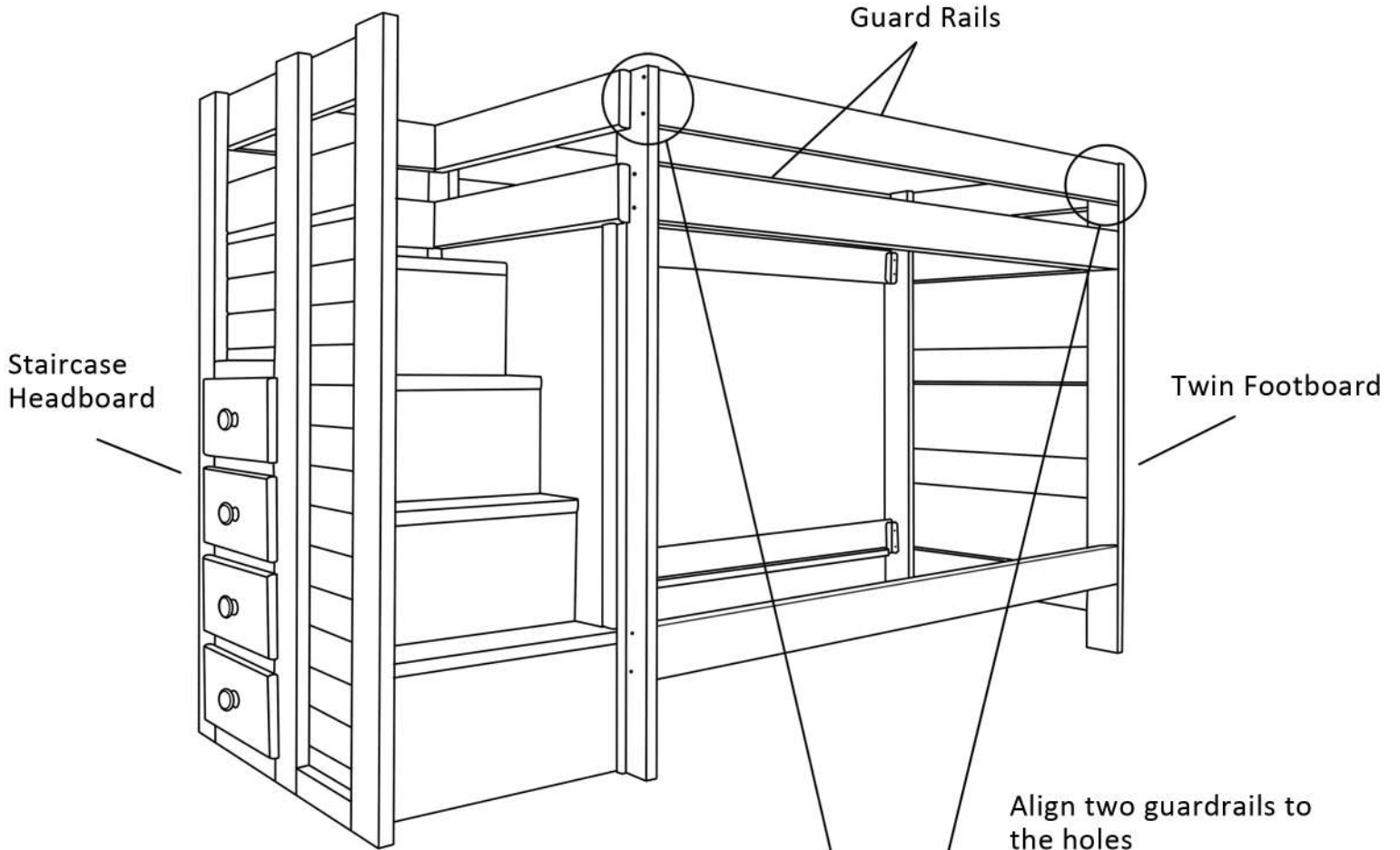

Align two guardrails to the holes of Staircase Headboard and Twin Footboard, then secure by using screws (#D).

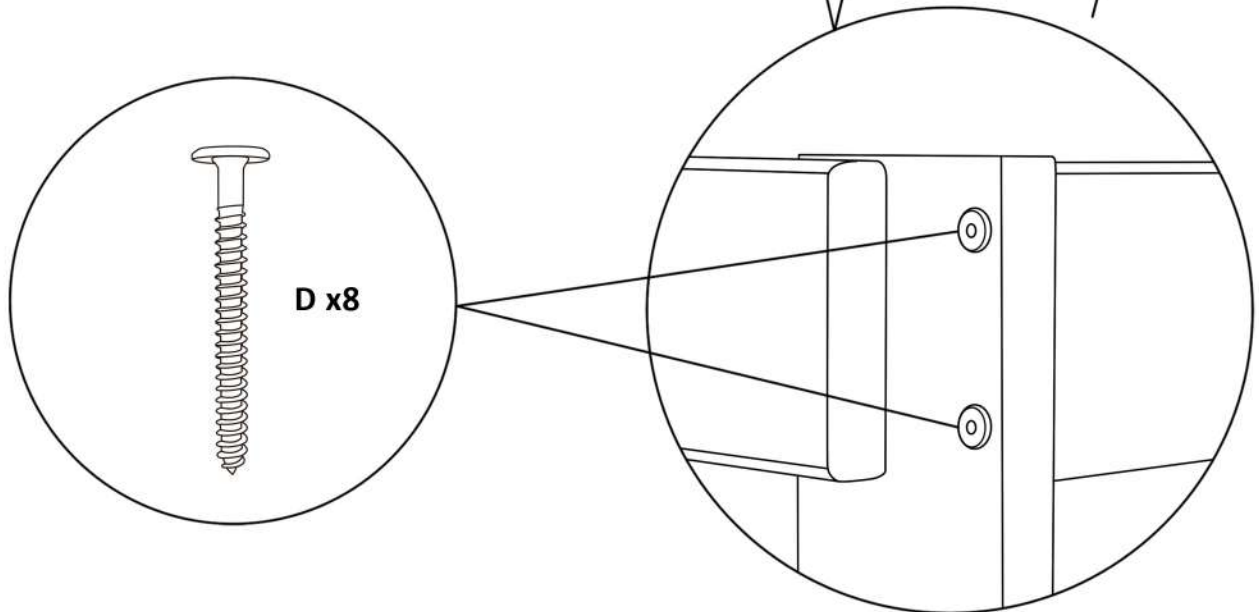

STEP 4

Caution: Please ensure all bolts and screws are fully tightened before use of product.

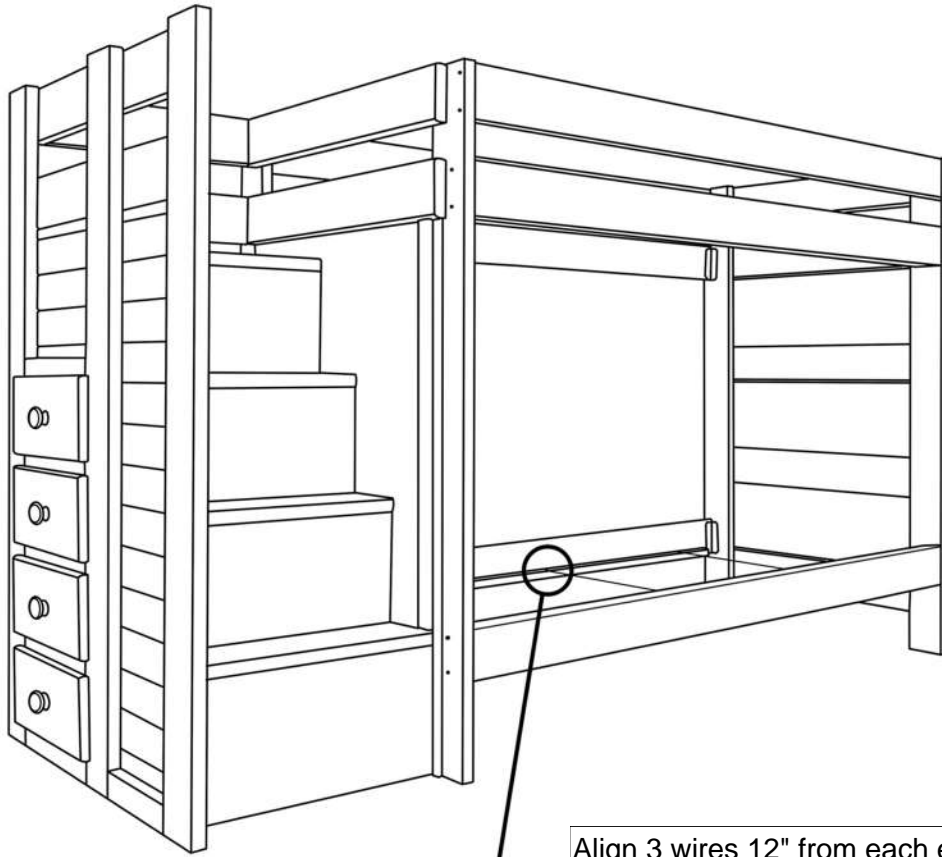

Align 3 wires 12" from each end and center on all top and bottom bunks. Then, secure screws (#A) as shown in the diagram.

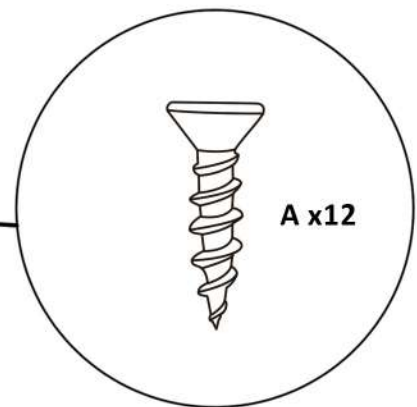
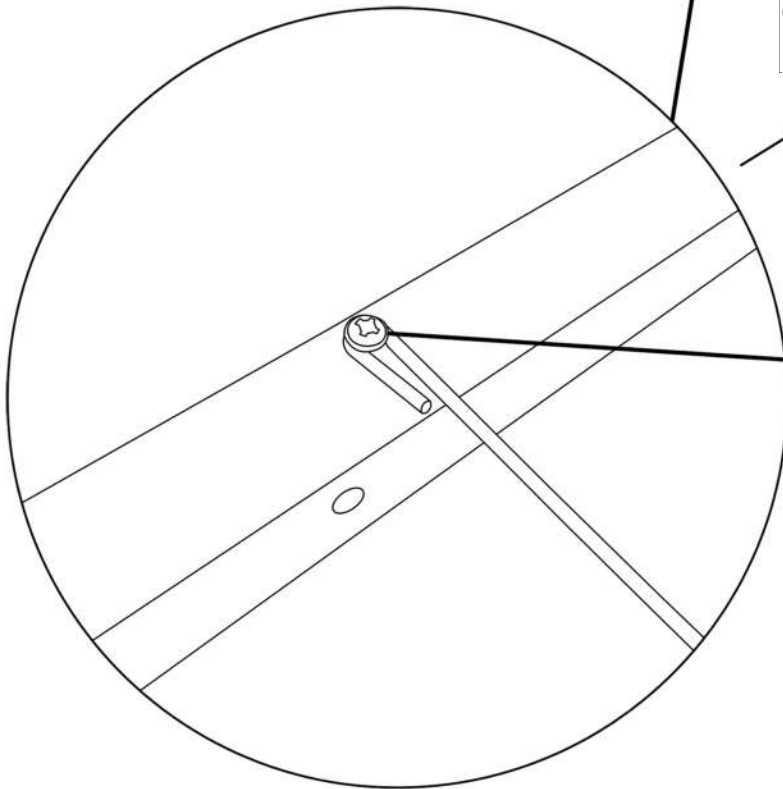

READ THESE INSTRUCTIONS CAREFULLY BEFORE ATTEMPTING TO ASSEMBLE THIS BED

⚠ WARNING ⚠

To help prevent serious or fatal injuries from entrapment or falls:

*Read & follow the information on the WARNING shown on the end structure of the upper bunk or on the carton.

***DO NOT** remove the warning label from the bed.

*Keep these instructions for future reference.

*Use only a mattress meeting the following specifications on all upper and lower bunks.

Bed Type	Width	Length		Bed Type	Width	Length
Standard Twin	37½"-38½"	74"-75"		XL Twin	37½"-38½"	79"-80"
Standard Full	52½"-53½"	74"-75"		XL Full	52½"-53½"	79"-80"

*Total thickness of both mattress and foundation combined **MUST NOT EXCEED 6"** for all top and bottom bunks.

*Surface of mattress must be at least 5 inches (127mm) below the upper edge of guardrails.

*The MAXIMUM weight capacity for the upper bunk is not to exceed 250 lbs.

***DO NOT** allow children under 6 years of age to use upper bunk.

*Periodically check and ensure that the guardrails, ladder, handle and other components are in their proper position, free from damage and that all connectors are tightened and secure.

***DO NOT** allow horseplay, rough playing or jumping on the beds and do not allow playing or hiding under the beds.

*Always use the ladder for entering or leaving the upper bunk.

***DO NOT** use substitute parts. Contact the manufacturer or dealer for replacement parts.

*Use of a nightlight may provide added safety precaution for a person using the upper bunk.

*Always use the guardrails on both sides of the upper bunk.

*If the bunk bed will be placed next to a wall, the guardrails that run the full length of the bed should be placed against the wall to prevent entrapment between the bed and the wall.

*The use of water or sleep flotation mattresses is prohibited.

*No more than one person is allowed on the upper bunk at a time.

STRANGULATION HAZARD: Never attach or hang objects to any part of the bed that are not designed for use with the bed. Objects such as hangers, hooks, belts, bags, ropes, string, etc. should not be used on or around the bunk bed.

DO NOT REMOVE THIS LABEL

BUNKIE MATTRESS OR BUNKIE BOARD MUST BE USED WITH THIS BUNK BED – MAXIMUM WEIGHT LIMIT IS 250 LBS.

REPLACEMENT PARTS

Replacement parts, including additional guardrails, may be obtained from us.