

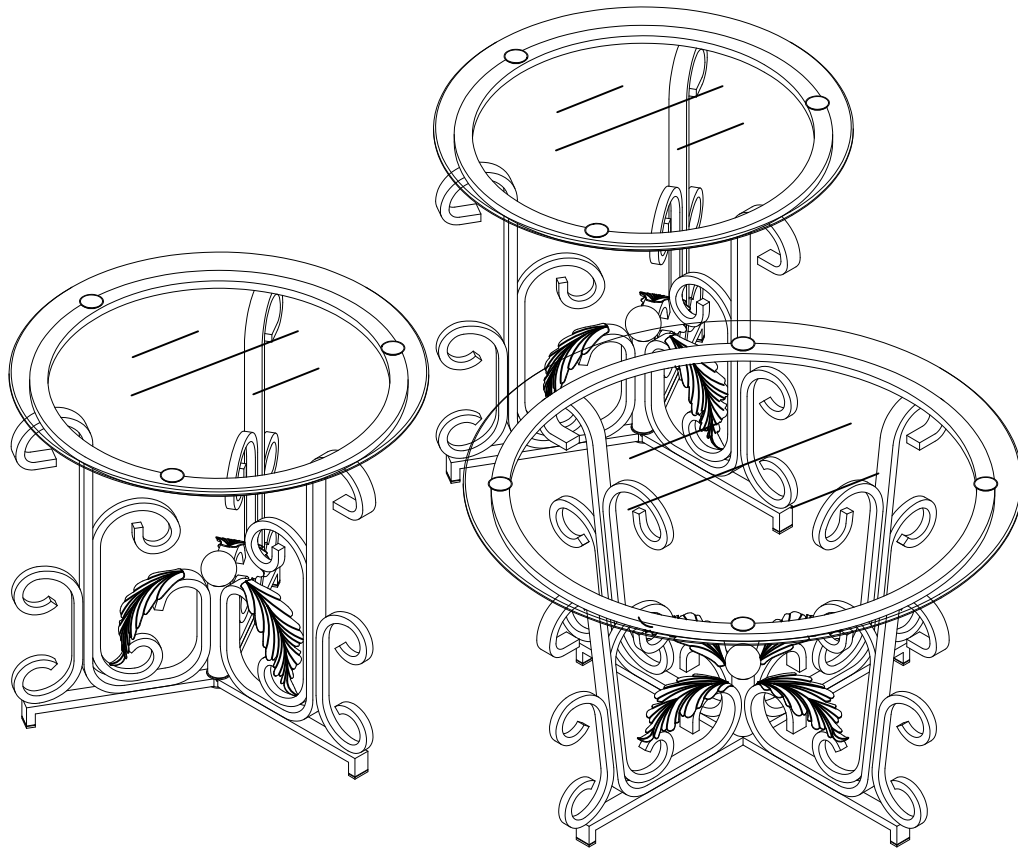

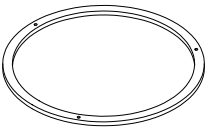

# ASSEMBLY INSTRUCTIONS

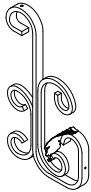

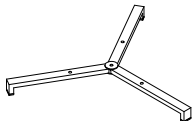

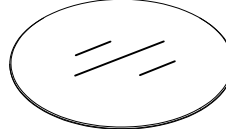
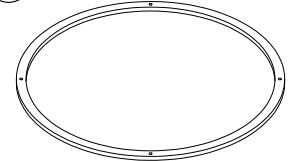

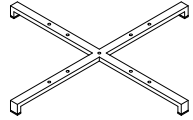
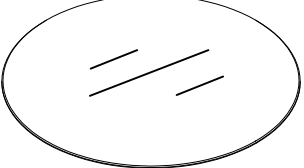
## PARTS LIST

|   |   |  |
|---|---|--|
| <p>① x2</p>  | <p>② x6</p>  | <p>③ x2</p>  |
|---|---|--|

|   |   |   |
|---|---|---|
| <p>④ x2</p>  | <p>⑤ x2</p>  | <p>⑥ x1</p>  |
| <p>⑦ x4</p>  | <p>⑧ x1</p>  | <p>⑨ x1</p>  |
| <p>⑩ x1</p>  |   |   |

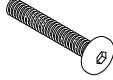
## HARDWARE LIST

|  |  |   |   |  |
|--|--|---|---|--|
| <p>A x10</p>  <p>1/4 X 3/4</p> | <p>B x21</p>  <p>1/4 X 1</p> | <p>C x2</p>  <p>1/4 X 1-1/2</p> | <p>D x10</p>  | <p>E x1</p>  |
|--|--|---|---|--|

When the process of product assembly, please do not lock the screws at one time, but wait until all the screws are assembled to the position, and then straighten and flatten the product, and then tighten the screws of the same height in turn, so as to avoid unsmooth assembly and product tilt.



DURING THE ASSEMBLY PROCESS, DO NOT TIGHTEN ALL SCREWS AFTER ASSEMBLY, AND TIGHTEN ALL SCREWS.

# ASSEMBLY INSTRUCTIONS

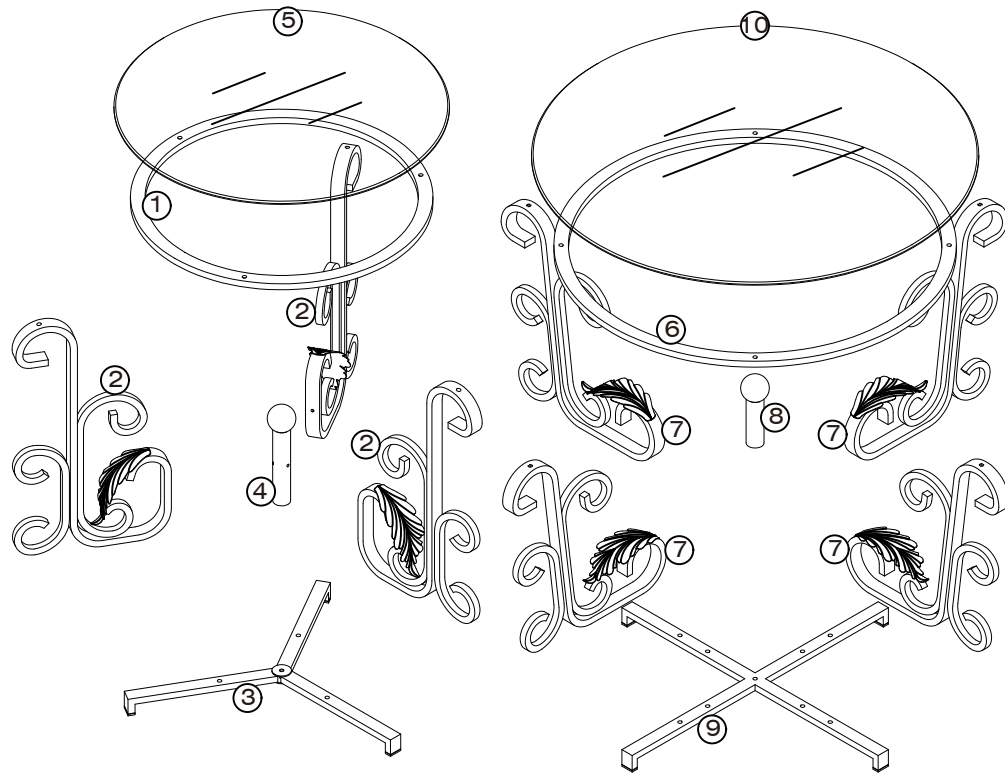

## STEP 1



x2

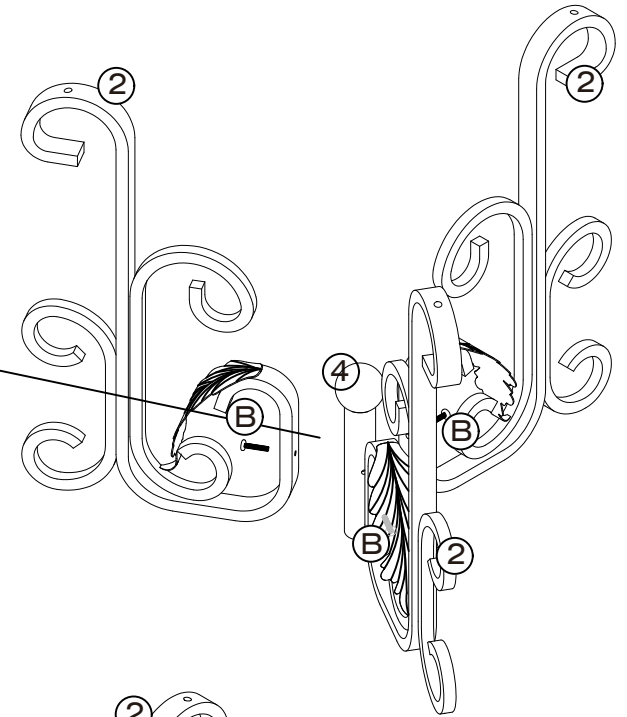
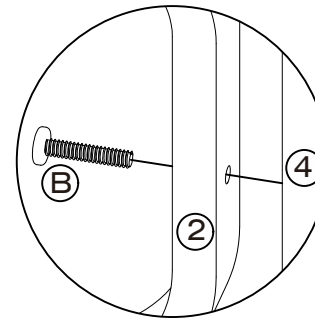

## STEP 2



x2

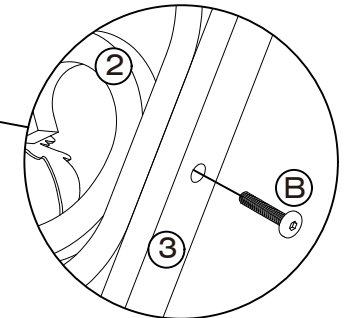
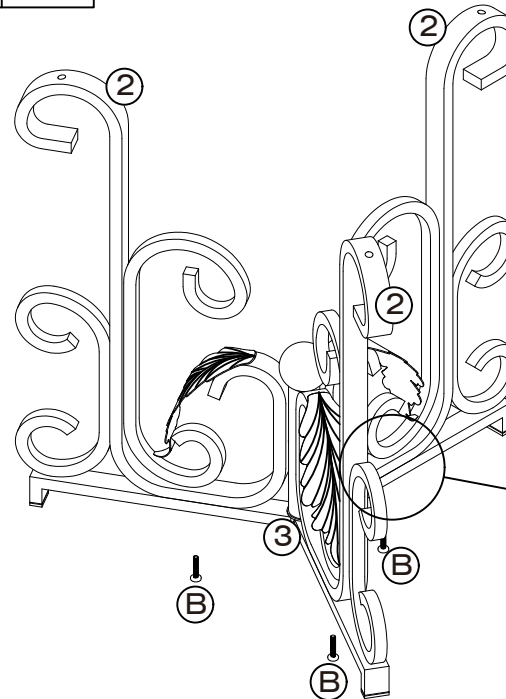

# ASSEMBLY INSTRUCTIONS

STEP 3

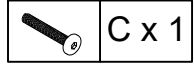

x2

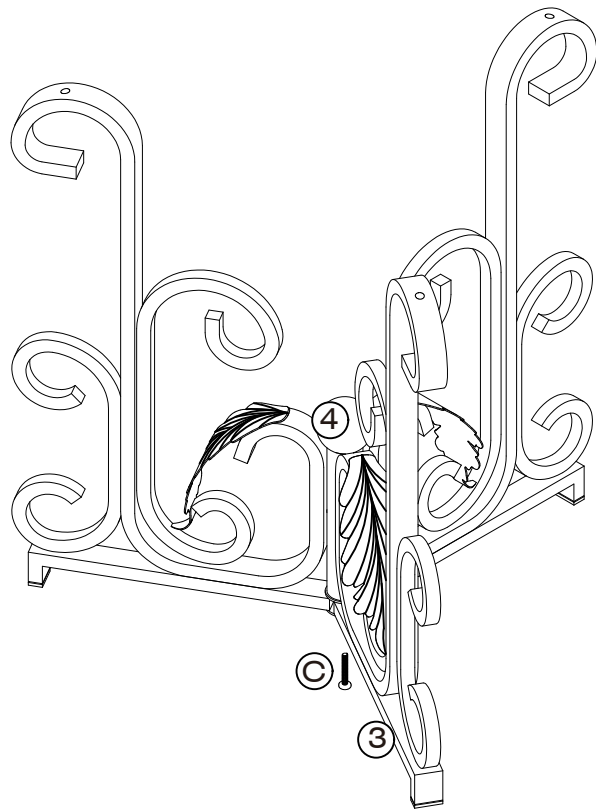

STEP 4

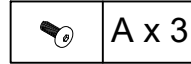

x2

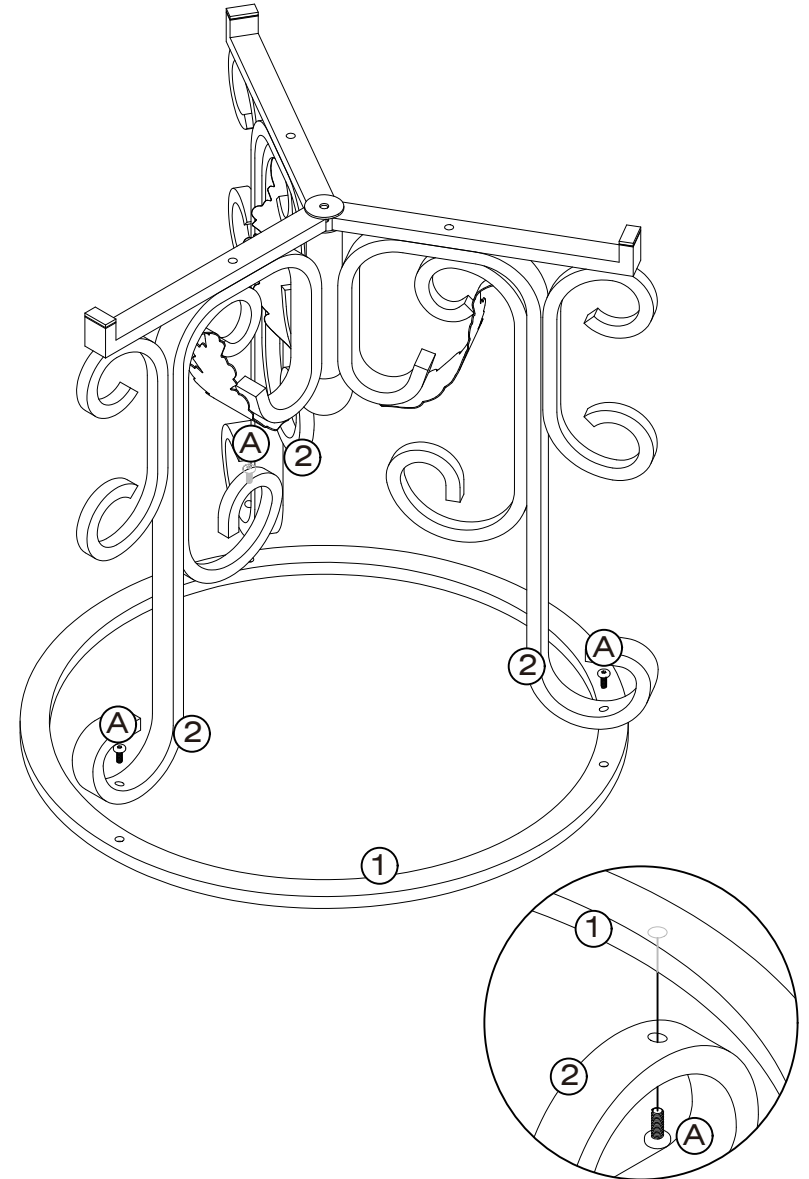

# ASSEMBLY INSTRUCTIONS

STEP 5



x2

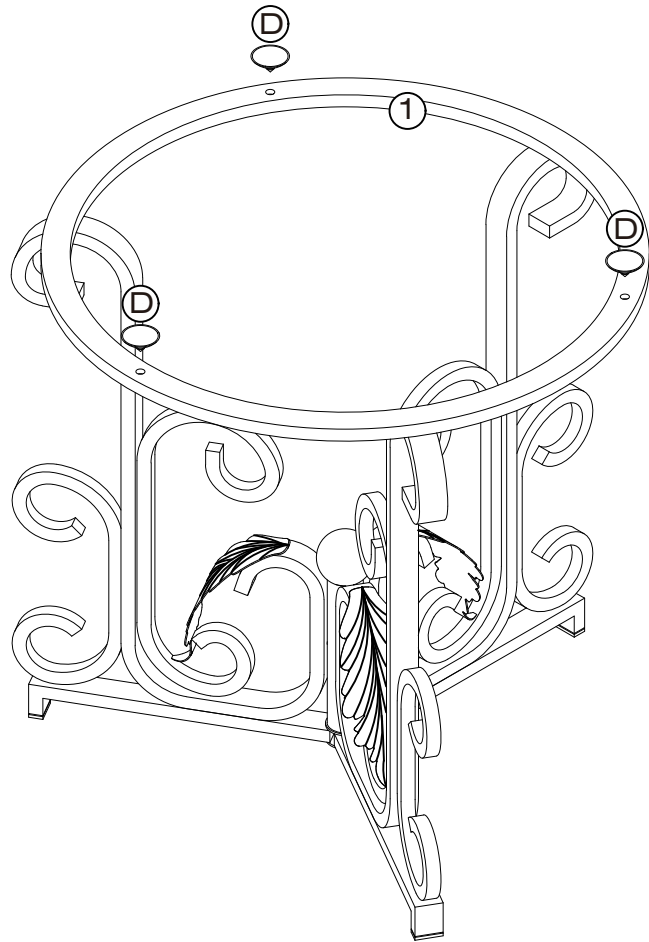

STEP 6

x2

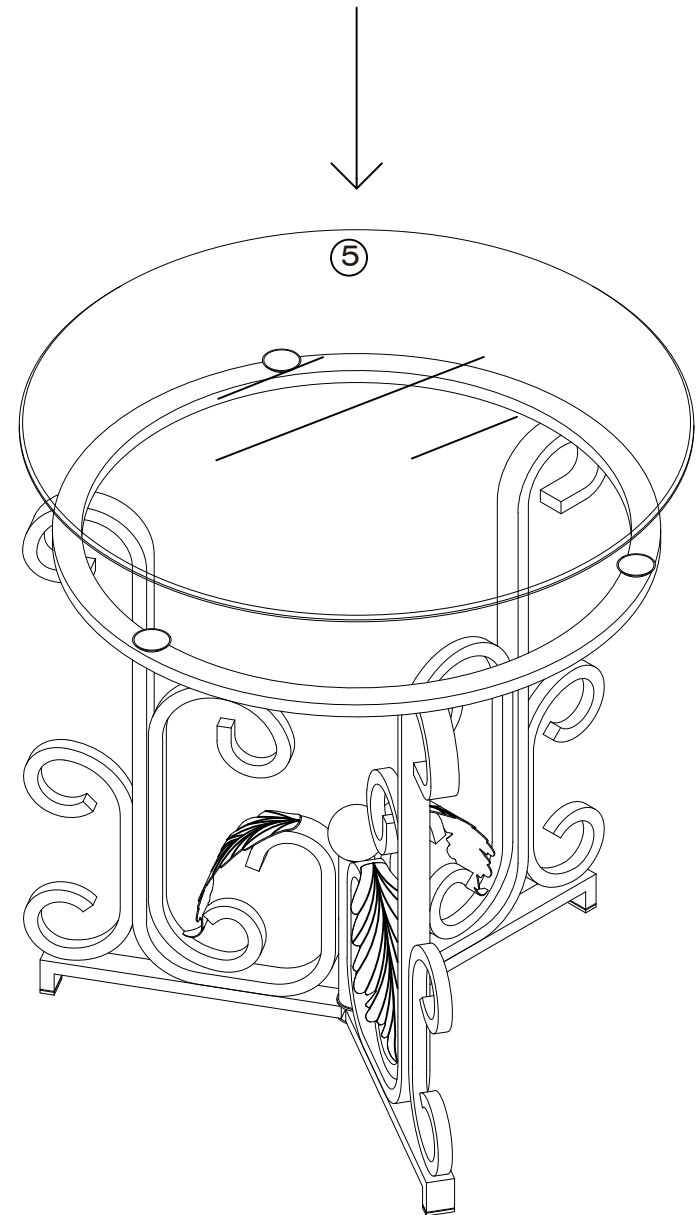

# ASSEMBLY INSTRUCTIONS

## STEP 7

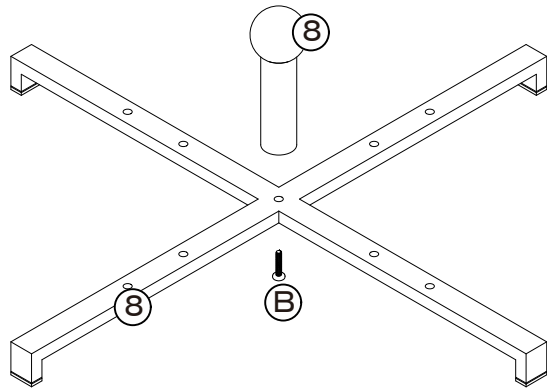

## STEP 8

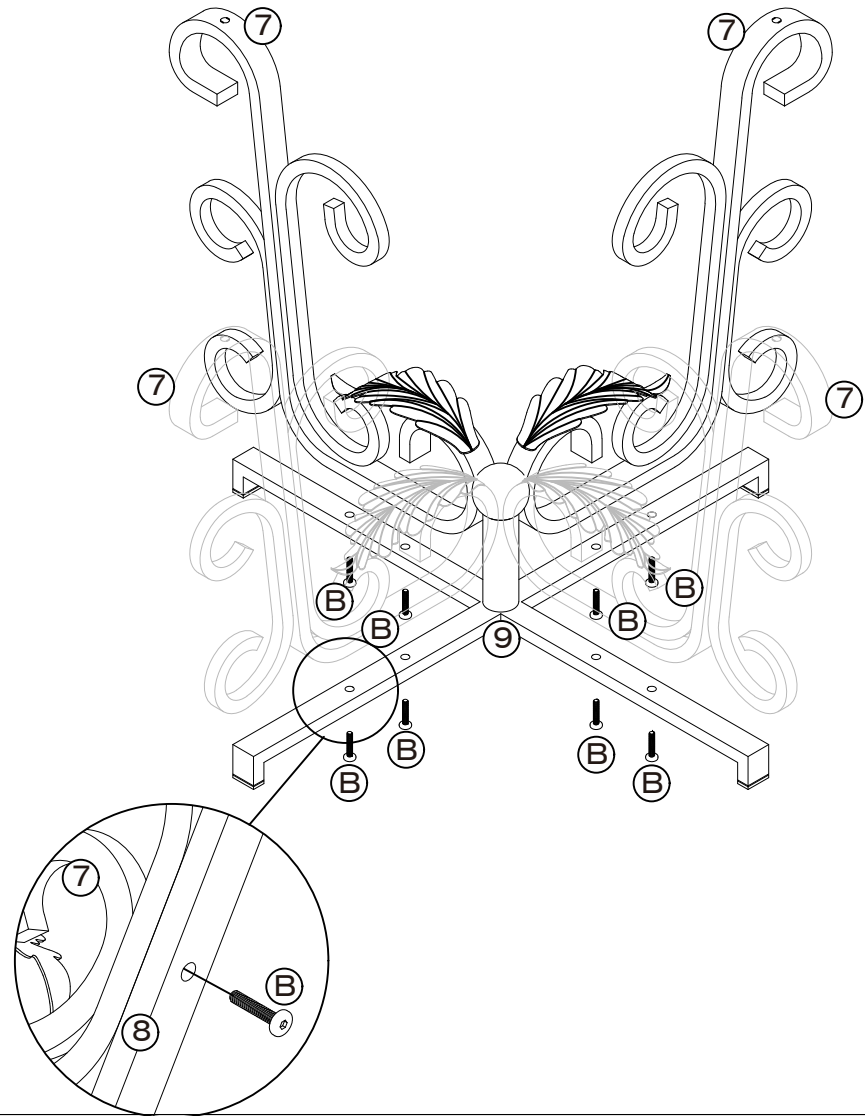
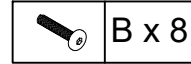

# ASSEMBLY INSTRUCTIONS

## STEP 9

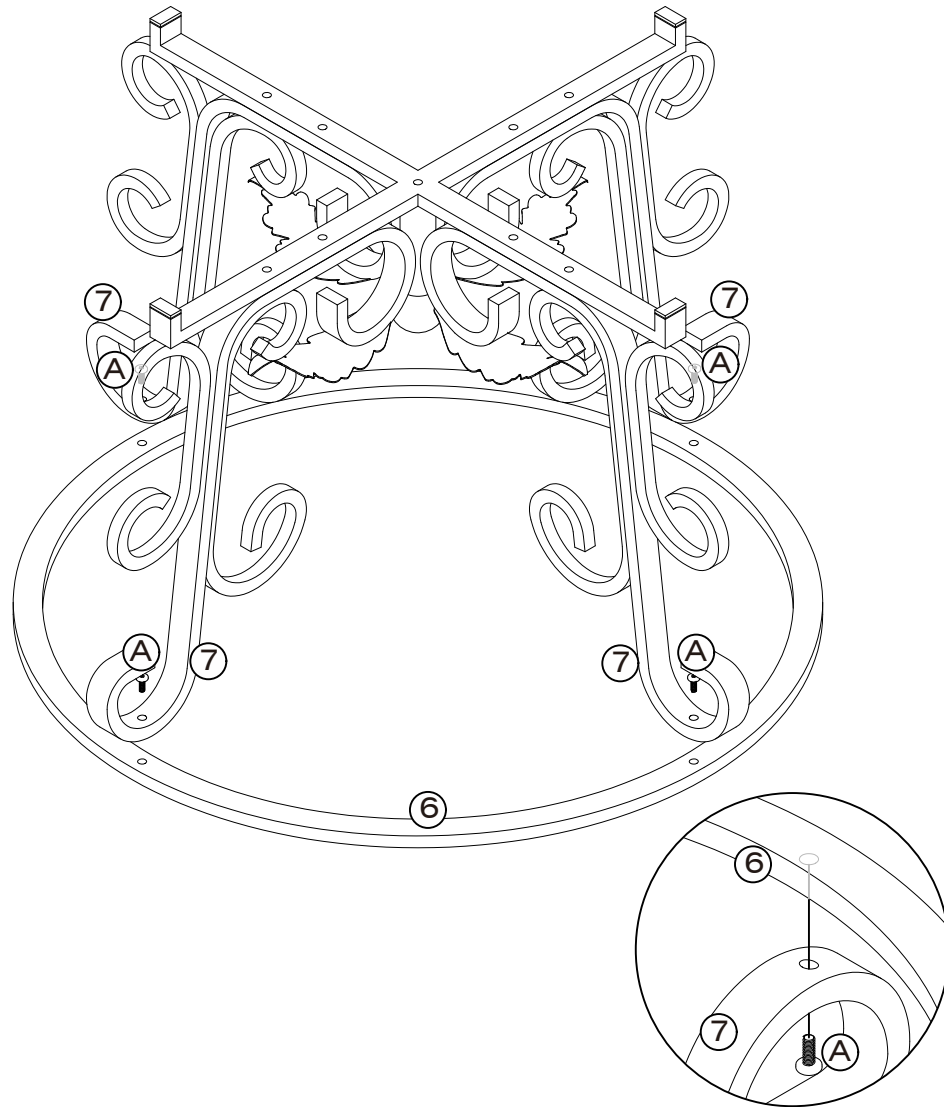
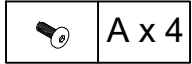

## STEP 10

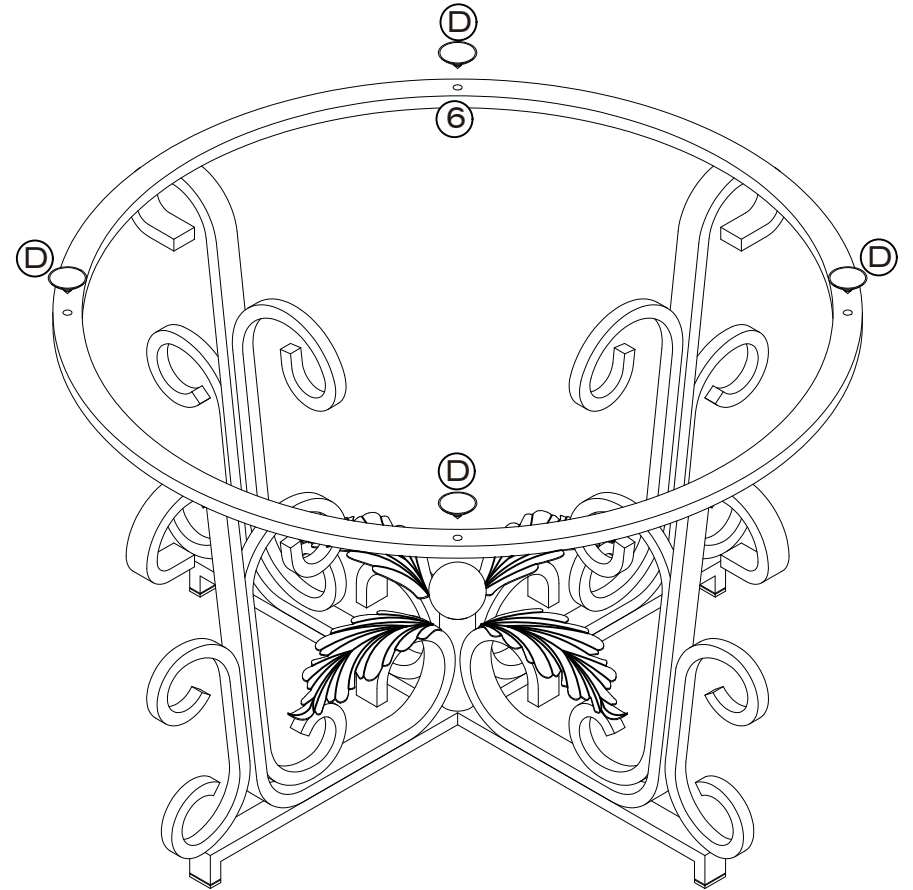

# ASSEMBLY INSTRUCTIONS

STEP 11

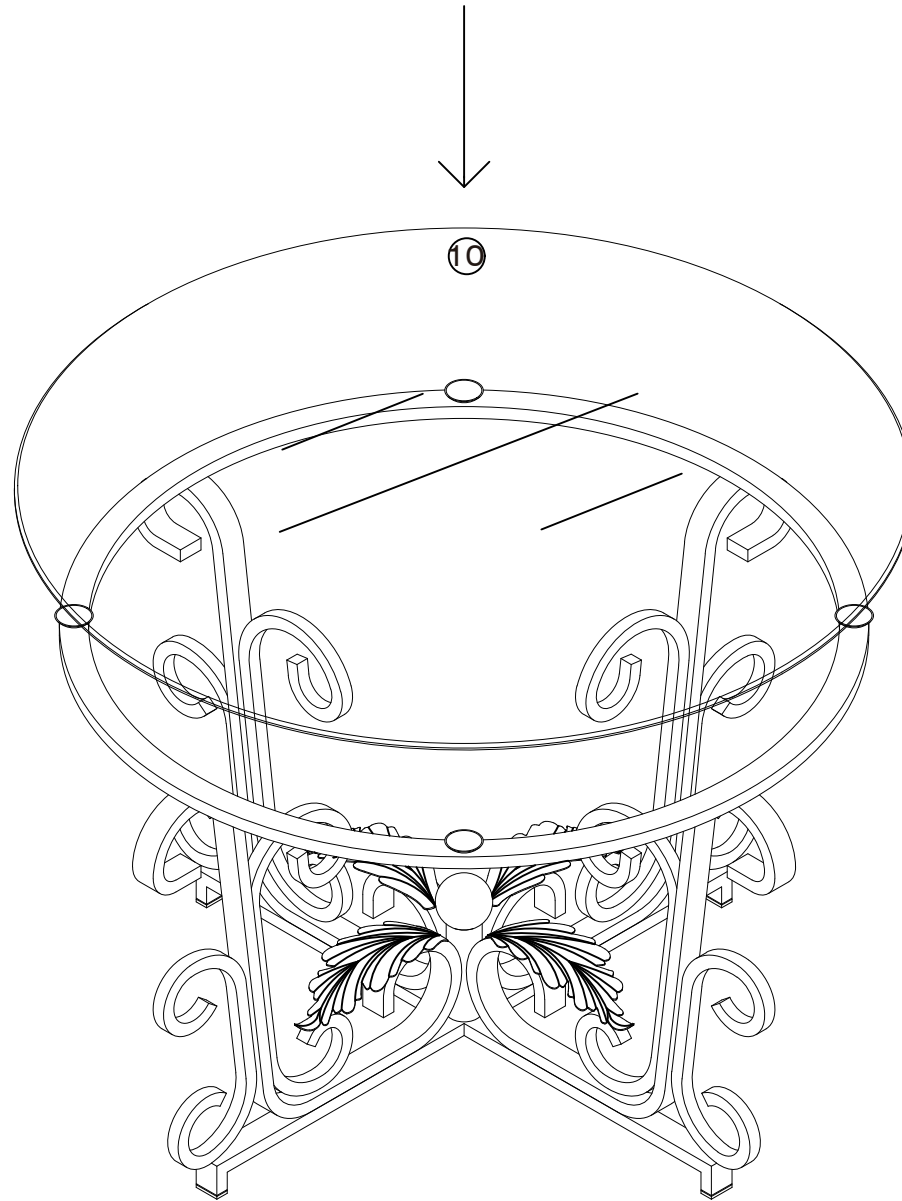

Check and tighten all screws