







# ASSEMBLY INSTRUCTIONS

FULL HEADBOARD  
 QUEEN HEADBOARD  
 E.KING/CALKING HEADBOARD

Thank you for purchasing this product. Please take time to read and follow the instructions below. Check that you have all parts and hardware before assembly. Parts apparently missing are often found in the packing materials. If you do not have all the parts listed, have your dealer contact us and they be sent to you immediately.

**⚠** It is recommended to install protective pads under all legs and supports to avoid damage or scratches when placing furniture on a wood floor or other hard surface, and to limit indentation and prevent discoloration if placing on carpet.

HARDWARE LIST				
No.	Description	Sketch	Size	Quantity
1	Allen Bolt		Ø5/16" x 45mmL	6 PCS
2	Spring Washer		Ø5/16"	6 PCS
3	Flat Washer		Ø5/16" x 19mmL	6 PCS
4	Allen Bolt		Ø1/4" x 38mmL	4 PCS
5	Allen Key		4mmL	1 PC

PARTS LIST			
No.	Description	Sketch	Quantity
A	Headboard		1 PC
B	Right Headboard Post		1 PC
C	Left Headboard Post		1 PC
D	Wood Block 80*30*20 mmL		2 PCS

**STEP 1 :** Attached the Wood Block(D) to the Right & Left Headboard Post(B&C) by using Allen Bolt(4) and Allen Key(5).

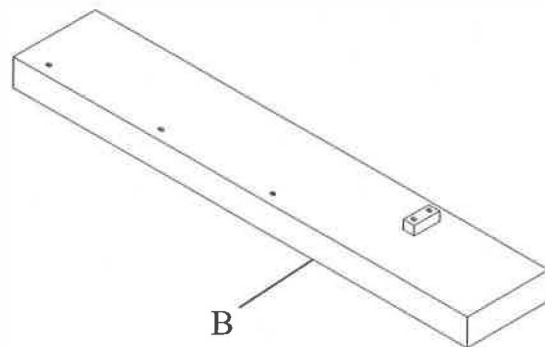
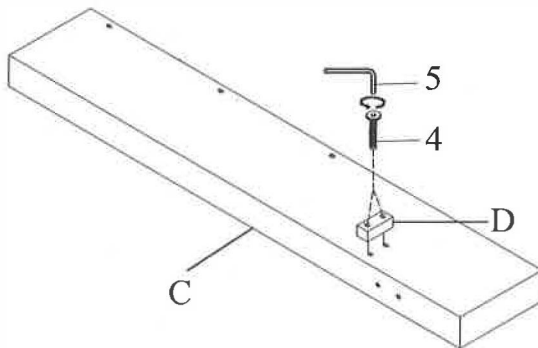

# ASSEMBLY INSTRUCTIONS

FULL HEADBOARD  
QUEEN HEADBOARD  
E.KING/CALKING HEADBOARD

**STEP 2** : Attached the Right & Left Headboard Post(B&C) to the Headboard(A) by using Allen Bolt(1), Spring Washer(2), Flat Washer(3) and Allen Key(5).

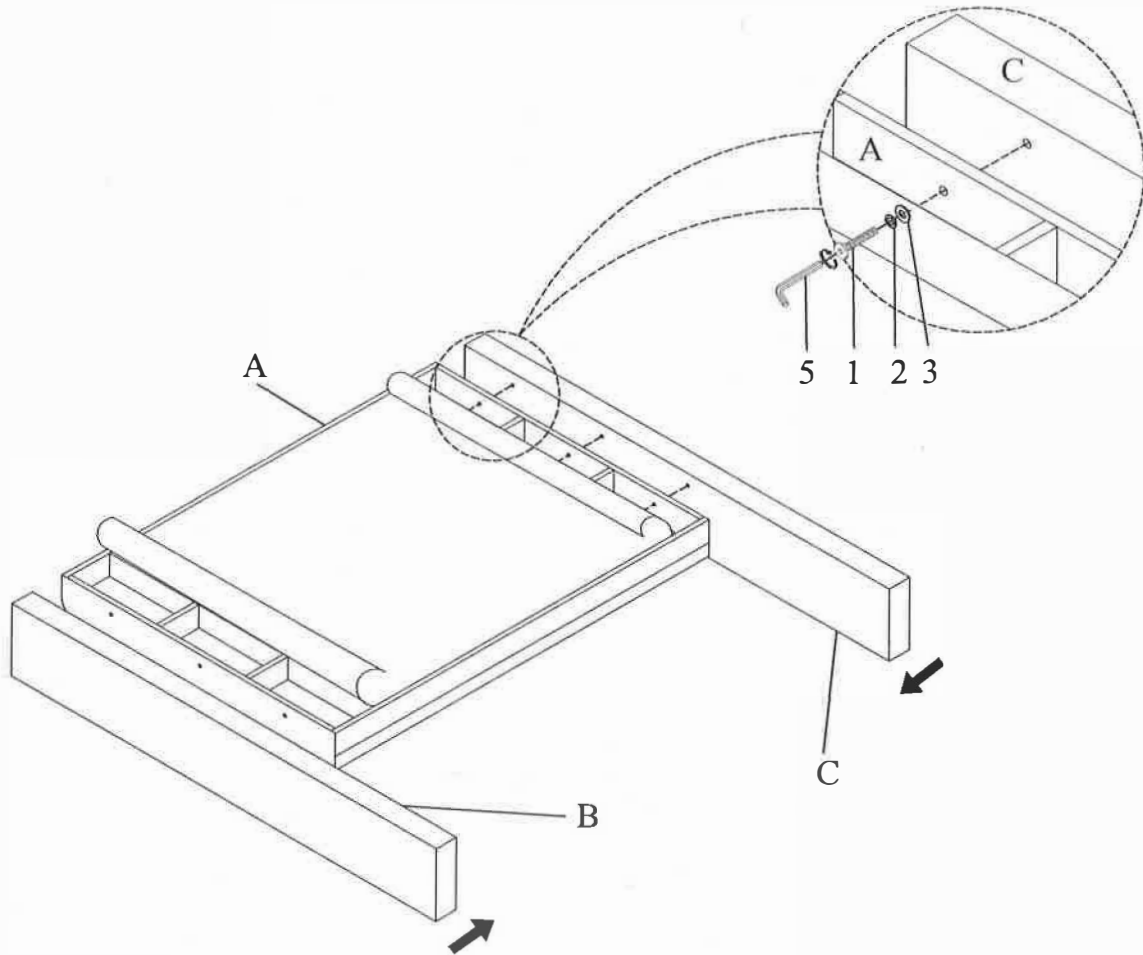







# ASSEMBLY INSTRUCTIONS

- FULL FOOTBOARD + SIDERAILS WITH 13PCS SLATS
- QUEEN FOOTBOARD + SIDERAILS WITH 13PCS SLATS
- E.KING FOOTBOARD + SIDERAILS WITH 13PCS SLATS

Thank you for purchasing this product. Please take time to read and follow the instructions below. Check that you have all parts and hardware before assembly. Parts apparently missing are often found in the packing materials. If you do not have all the parts listed, have your dealer contact us and they be sent to you immediately.

**!** It is recommended to install protective pads under all legs and supports to avoid damage or scratches when placing furniture on a wood floor or other hard surface, and to limit indentation and prevent discoloration if placing on carpet.

HARDWARE LIST				
No.	Description	Sketch	Size	Quantity
1	Thread Bolt		Ø5/16" x 80mmL	8 PCS
2	Curve Washer		Ø5/16"	8 PCS
3	Hex Nut		Ø5/16"	8 PCS
4	Screw		#4 x 30mmL	27 PCS
5	Allen Bolt		Ø1/4" x 38mmL	2 PCS
6	Open Wrench		Ø5/16"	1 PC
7	Allen Key		4mmL	1 PC

PARTS LIST			
No.	Description	Sketch	Quantity
A	Headboard		1 PC
B	Footboard		1 PC
C	Side Rail		2 PCS
D	Slat Roll		1 Set
E	Center Slat Support		1 PC
F	Support Leg		4 PCS
G	Wood Block		1 PC

**STEP 1 :** Attached the Wood Block(G) to the Footboard(B) by using Allen Bolt(5) and Allen Key(7).

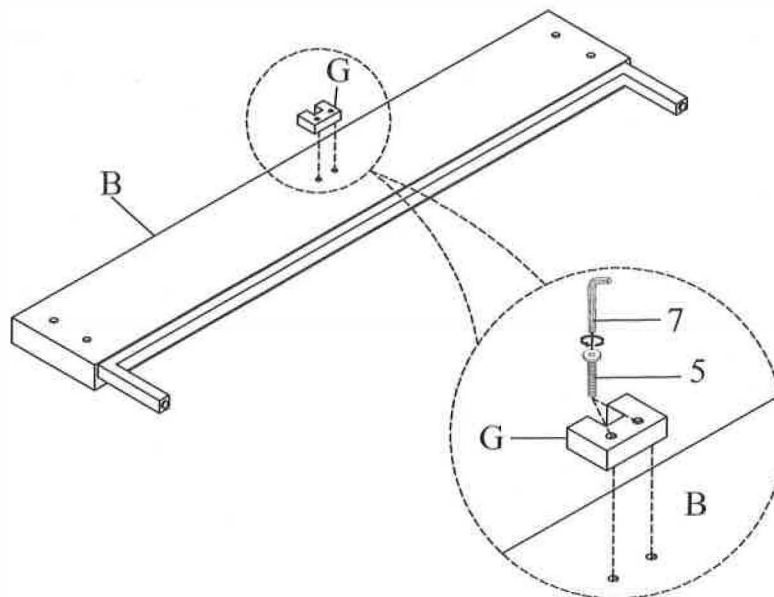

# ASSEMBLY INSTRUCTIONS

FULL FOOTBOARD + SIDERAILS WITH 13PCS SLATS  
QUEEN FOOTBOARD + SIDERAILS WITH 13PCS SLATS  
E.KING FOOTBOARD + SIDERAILS WITH 13PCS SLATS

**STEP 2 :** Attach Side Rail(C) to Headboard(A) and Footboard(B) by using Thread Bolt(1), Curve Washer(2), Hex Nut(3) and Open Wrench(6).

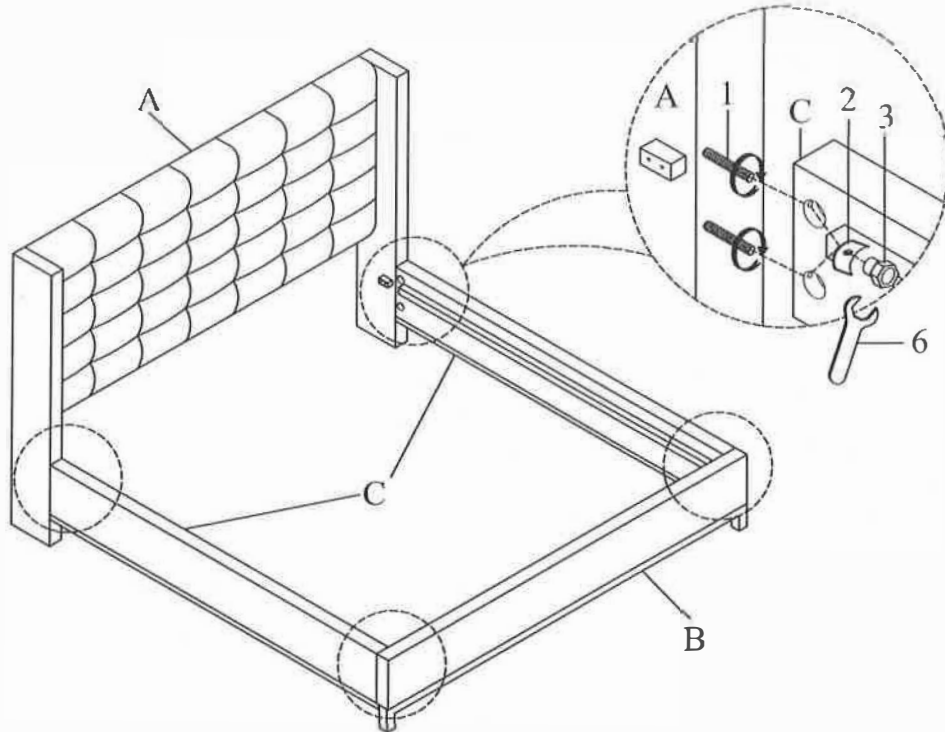

**STEP 3 :** Attached the Support Leg(F) and Center Slat Support(E) to the Slat Roll(D)

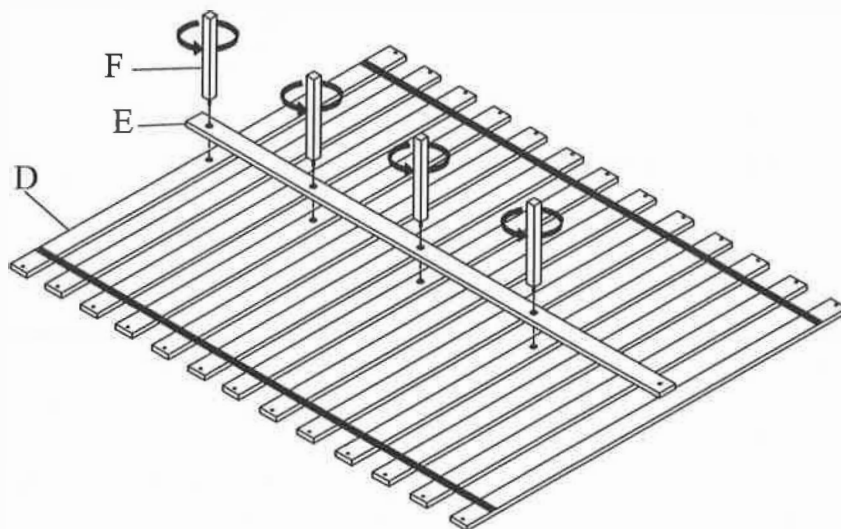

# ASSEMBLY INSTRUCTIONS

FULL FOOTBOARD + SIDERAILS WITH 13PCS SLATS  
QUEEN FOOTBOARD + SIDERAILS WITH 13PCS SLATS  
E.KING FOOTBOARD + SIDERAILS WITH 13PCS SLATS

**STEP 4 :** Then place Slat Roll(D) on Side Rail.

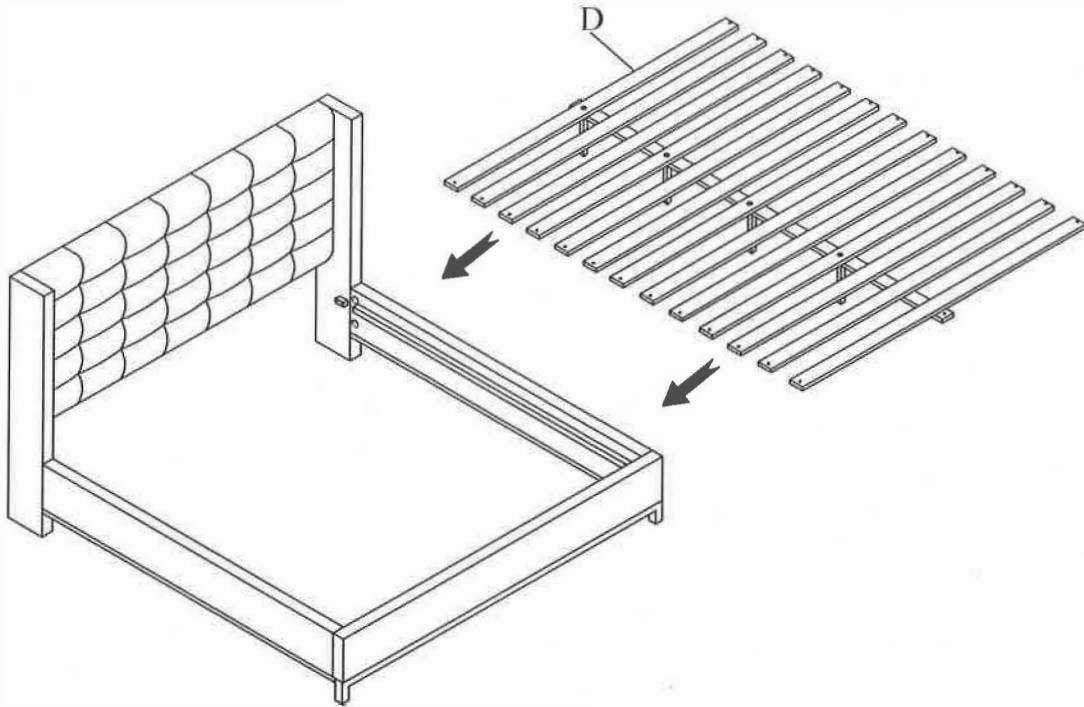

**STEP 5 :** Attached the Center Slat Support(E) to the Wood Block(G) by using Screw(4).  
Attached the Slat Roll(D) to the Side Rail(C) by using Screw(4).  
NOTE: SCREWDRIVER NOT INCLUDED.

**STEP 5.1**

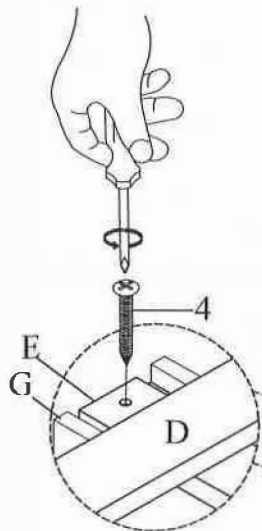

**STEP 5.2**

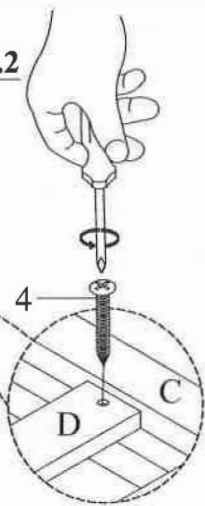

# ASSEMBLY INSTRUCTIONS

FULL FOOTBOARD + SIDERAILS WITH 13PCS SLATS  
QUEEN FOOTBOARD + SIDERAILS WITH 13PCS SLATS  
E.KING FOOTBOARD + SIDERAILS WITH 13PCS SLATS

**COMPLETE**

