

ASSEMBLY INSTRUCTIONS

ROUND END TABLE

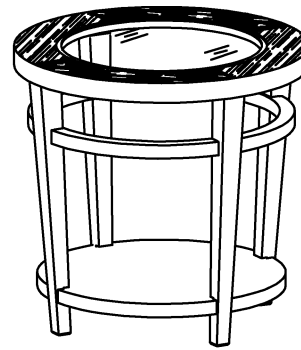

TOOLS REQUIRED:

ALLEN WRENCH (Provided, PART # E)

Phillips Head Screwdriver (Not Provided)

BEFORE YOU START:

1. Check the parts against the parts list to make sure all items are present.
2. Assemble your furniture on a soft, flat surface to avoid scratching the finish.
3. Caution: Do not over tighten screws, nuts or bolts during assembly.
4. Your furniture may require occasional tightening.

INSTRUCTIONS:

1. Turn the table top upside down on a clean soft surface.
2. First, attach two legs to the table using the Bolt (F), Lock Washer (G), Flat Washer (H), and tighten with Wrench (E). (Figure 1)
3. Attach the middle shelf frame and bottom shelf into the two legs, then attach other two legs to the table using Bolt (F), Lock Washer (G), Flat Washer (H) and tighten with Wrench (E). (Figure 1).
4. Install Screws (C) into middle shelf, then use Wood plug (D) cover the holes. (Figure 2)
5. Attach Angle Bracket (A) to each leg using Screws (B) (Figure 3).
6. Use Bolt (F), Lock Washer (G), and Flat Washer (H), and Wrench (E) to tighten the bottom shelf frame and angle bracket. (Figure 4)
7. Tighten all bolts and turn table upright.
8. Place glass top into the top frame.

Figure 1

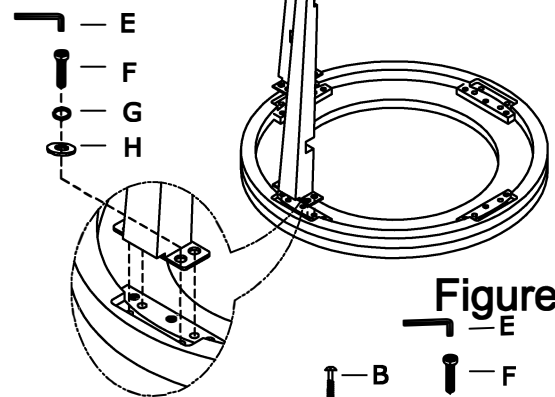

Figure 4

Figure 3

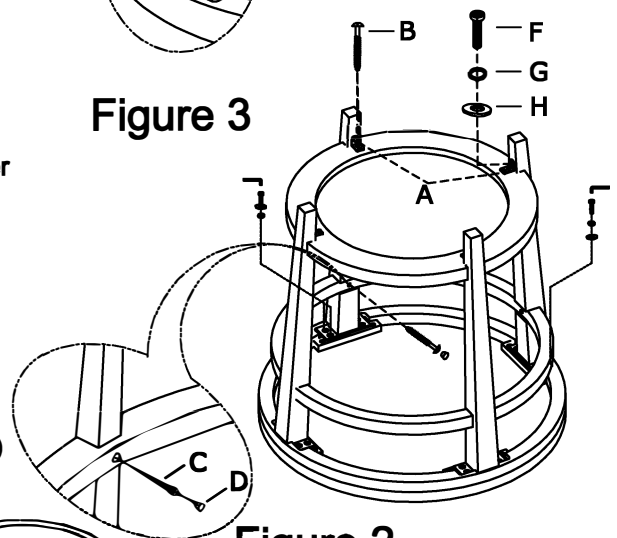
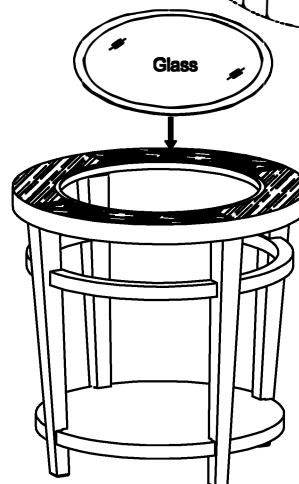









Figure 2



HARDWARE LIST		
NO. Drawing	Description	QTY
A	 Angle Bracket	4 pcs
B	 #6*5/8" Screw	8 pcs
C	 #8*1-1/4" Screw	4 pcs
D	 Wood Plug	4 pcs
E	 Wrench 4mm	1 pc
F	 Allen Bolt (φ1/4"*3/4")	20 pcs
G	 φ1/4" Lock Washer	20 pcs
H	 φ1/4"*16mm Flat Washer	20 pcs

Thank you for purchasing furniture