

ASSEMBLY INSTRUCTION

NO	PART LIST	QTY
1	HEADBOARD CUSHION	1PC
2	LEFT HEADBOARD LEG (WITH "L" LABEL)	1PC
3	RIGHT HEADBOARD LEG (WITH "R" LABEL)	1PC
4	FOOTBOARD CUSHION	1PC
5	FOOTBOARD LEGS	2PCS
6	SIDE RAIL	2PCS
7	SIDE RAIL	2PCS
8	SIDE RAIL SUPPORT LEG	2PCS
9	SLATS	4PCS
NO	HARDWARE LIST	QTY
A	JCBB SCREW M8 X 20	8PCS
B	JCBC SCREW M6 X 25	8PCS
C	JCBC SCREW M6 X 35	6PCS
D	JCBC SCREW M6 X 70	2PCS
E	WOOD DOWEL M8 x 30mm	2PCS
F	SPRING WASHER M6 x 13mm	14PCS
G	FLAT WASHER M6 x 19mm	14PCS
H	SCREW M4 X 32mm	8PCS
I	L - KEY M5 X 65mm	1PC
J	L - KEY M4 X 100mm	1PC

STEP 1

Open zipper to get all other parts.

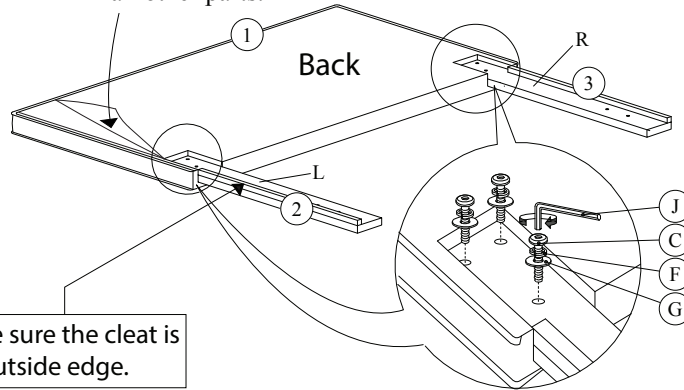

Make sure the cleat is on outside edge.

STEP 3

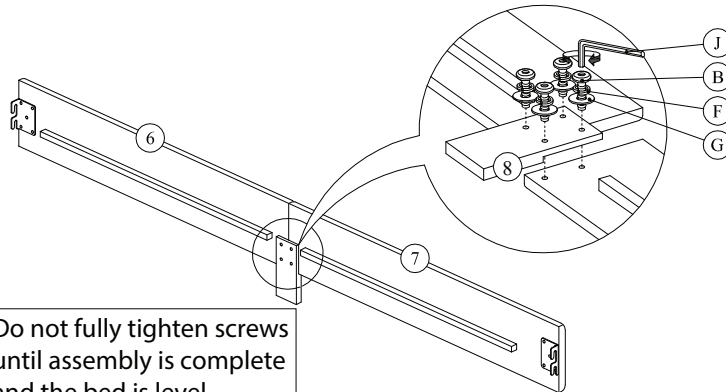

Do not fully tighten screws until assembly is complete and the bed is level.

STEP 5

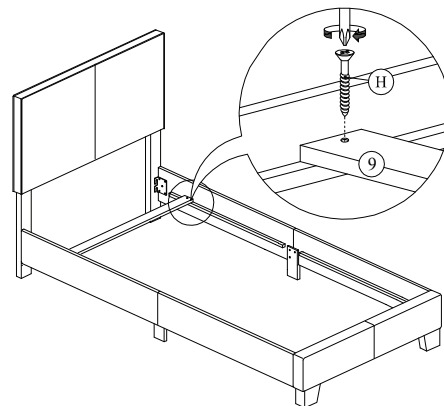

STEP 2

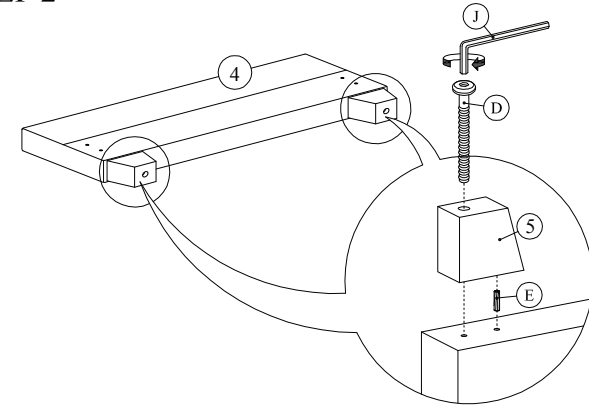

STEP 4

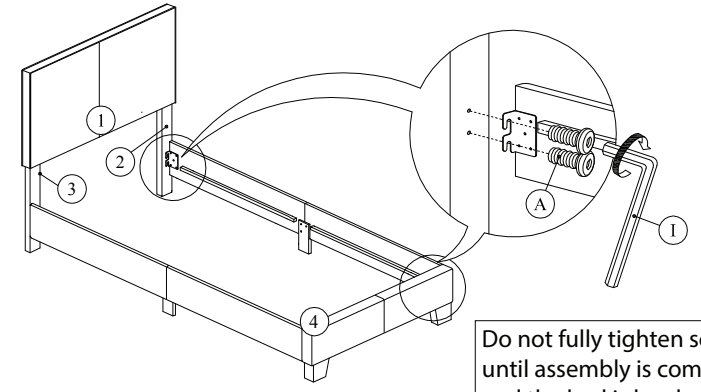

Do not fully tighten screws until assembly is complete and the bed is level.

ASSEMBLY COMPLETED