

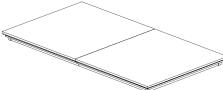







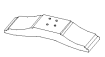

# ASSEMBLY INSTRUCTIONS

Description : Dining Table

NO	Parts List	Q'TY
1	TABLE TOP 	1PC
2	TABLE LEAF 	1PC
3	CONNECTING PANEL 	2PCS
4	TABLE LEG 	2PCS
5	TABLE POST 	2PCS
6	SHELF 	1PC

NO	Hardware List	Q'TY
A	BOLT  Ø5/16" * 40mm	12 PCS
B	LOCK WASHER  Ø5/16" * 11* 1.5 mm	28 PCS
C	WASHER  Ø5/16" * 22 *2 mm	28 PCS
D	NUT  Ø5/16" *12mm	16 PCS
E	ALLEN KEY  58 * 4mm	1PC
F	WRENCH  12 * 90mm	1PC

## STEP 1

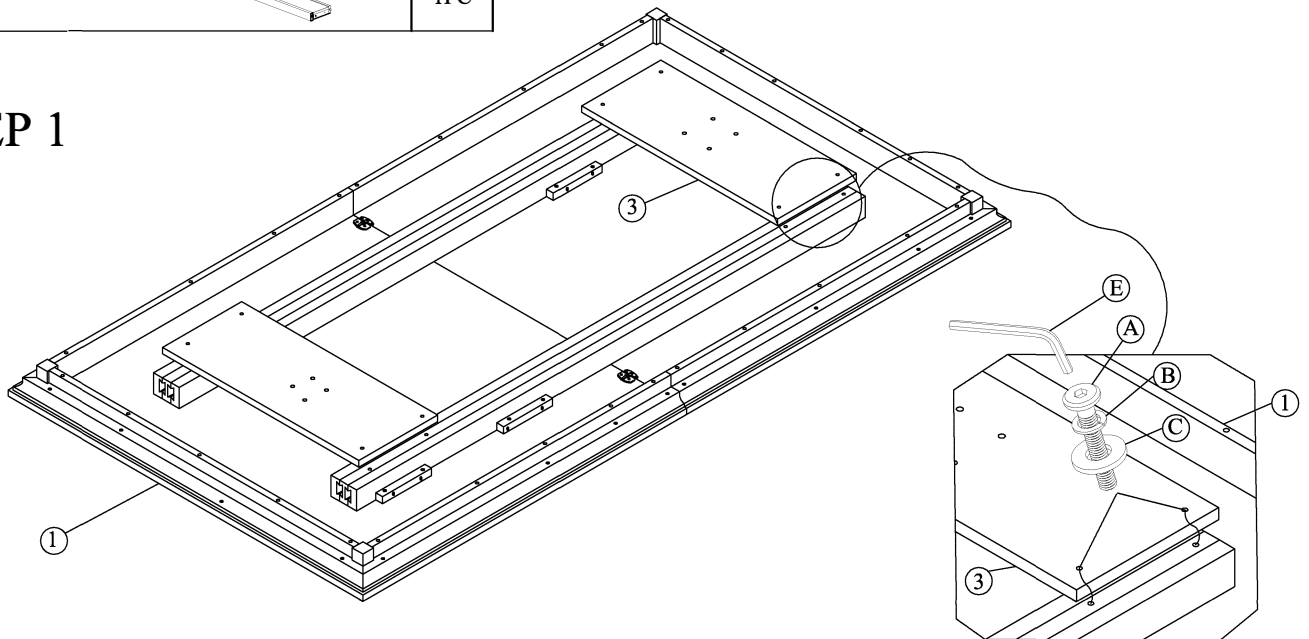

## STEP 2

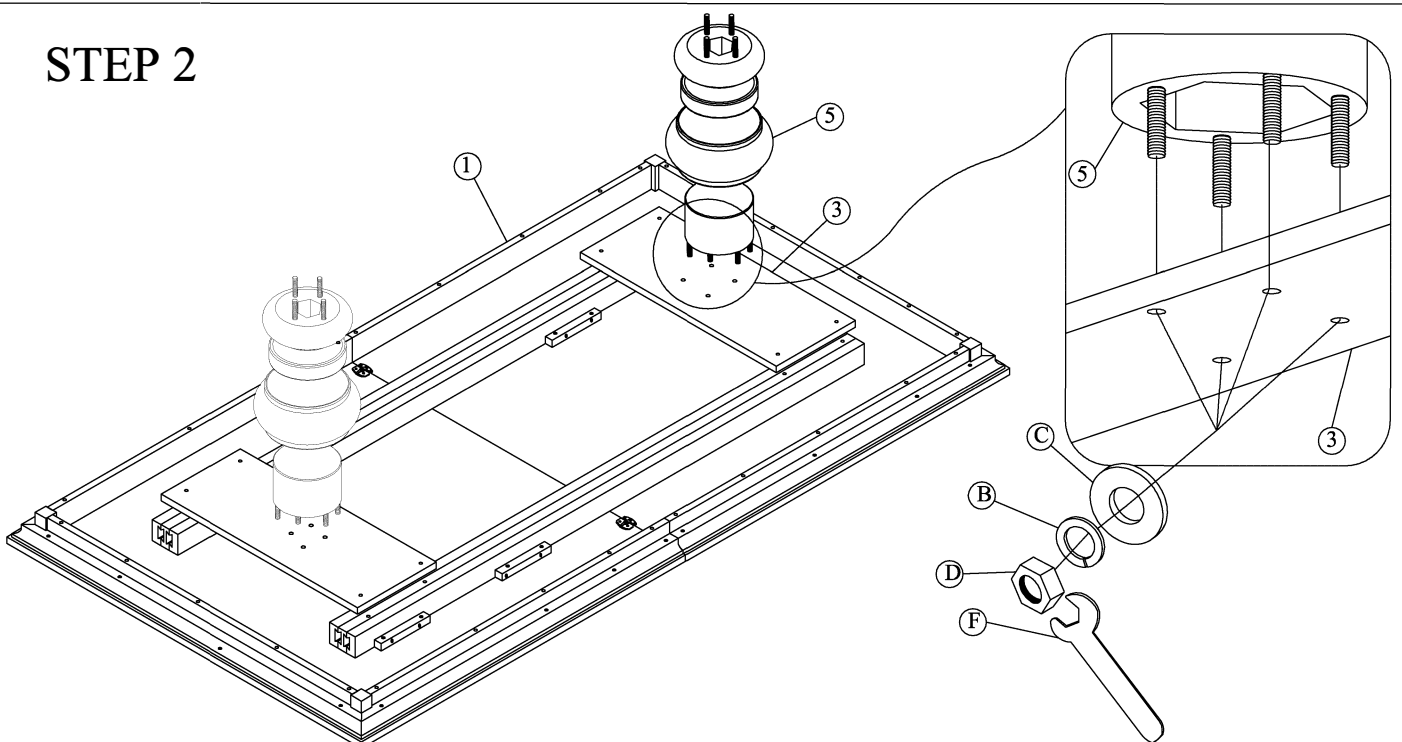

### STEP 3

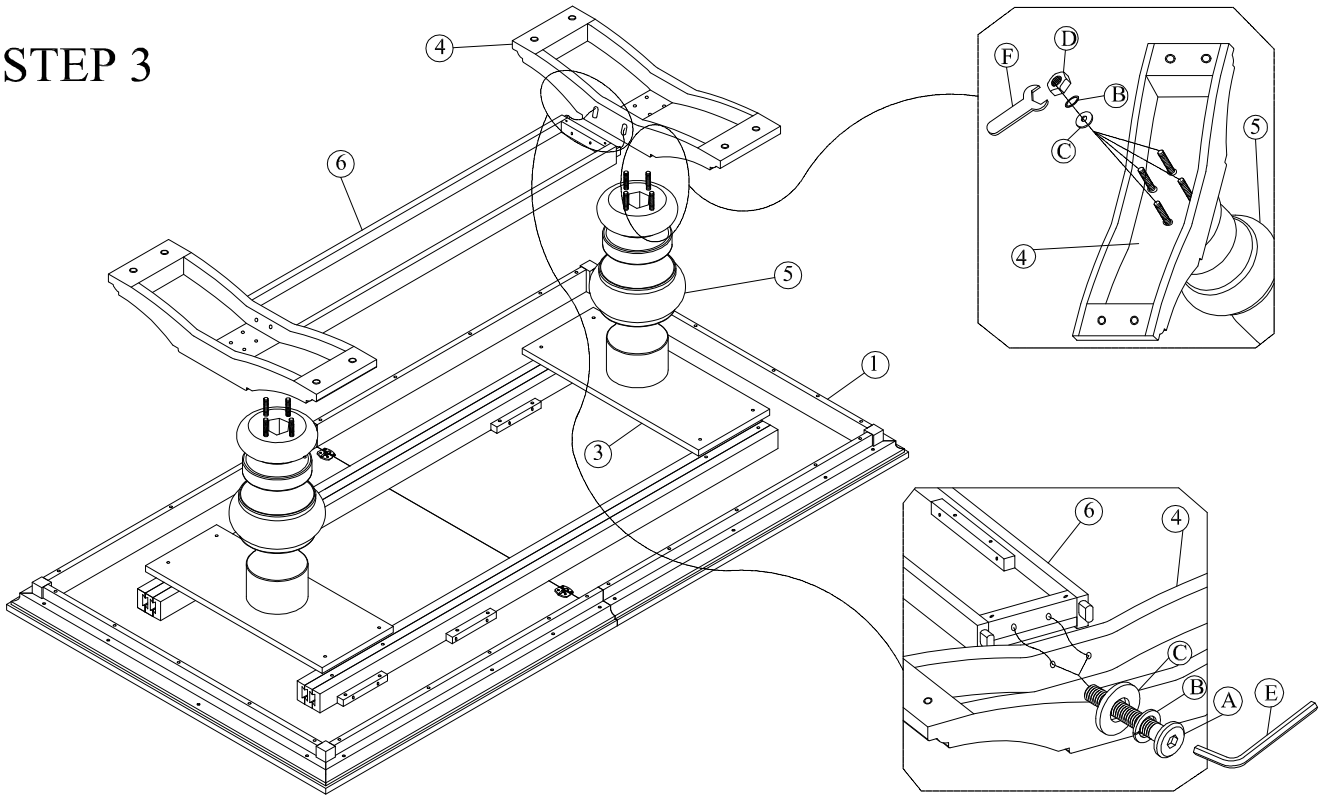

### STEP 4

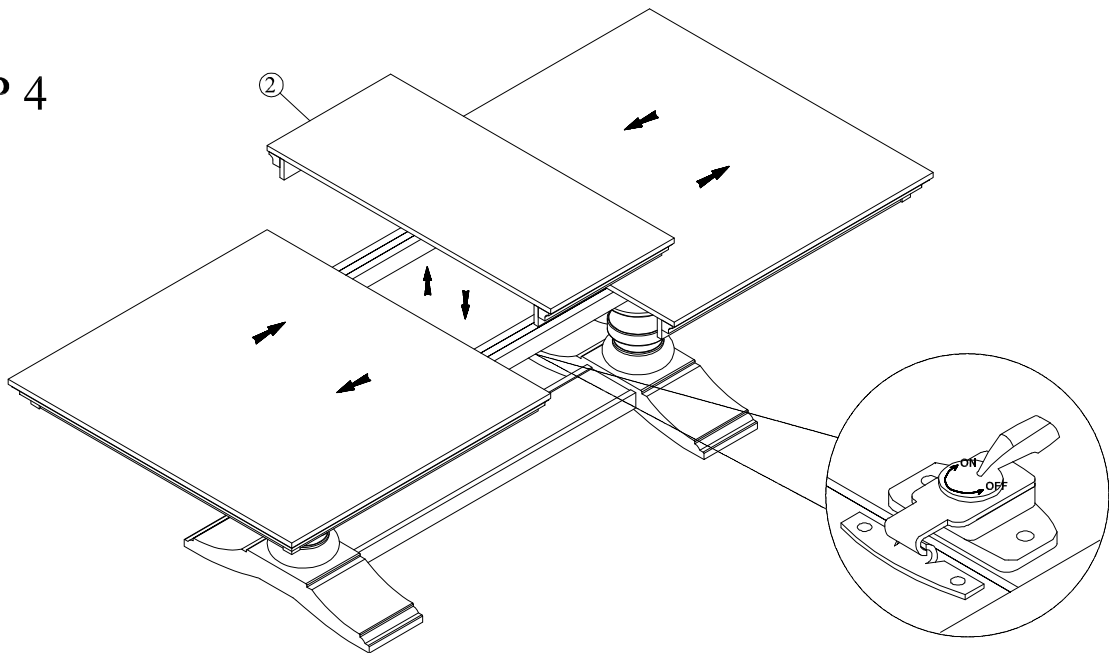



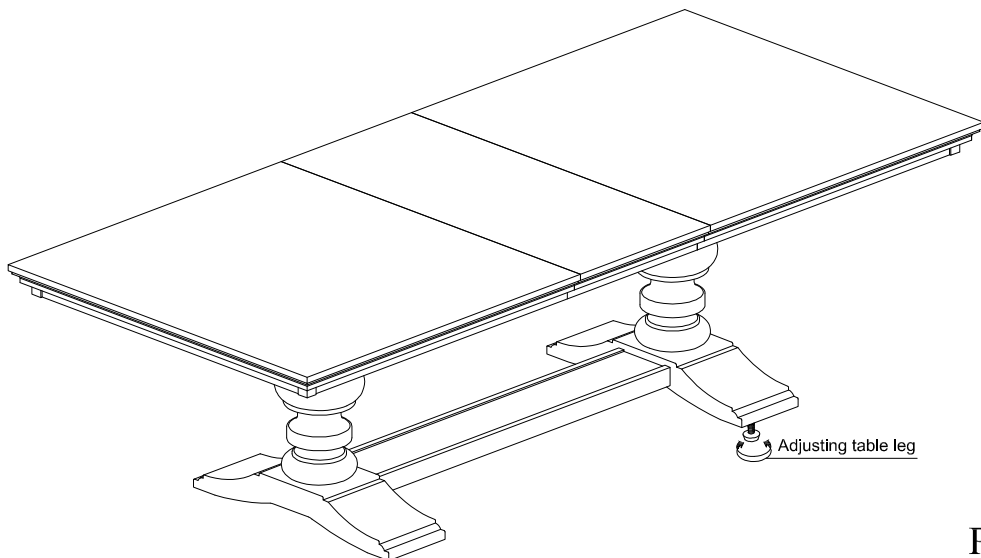



### STEP 5



# ASSEMBLY INSTRUCTIONS

Description : Wing Chair

NO	Parts List	Q'TY
1	CHAIR FRAME WITH CUSHION SEAT 	1PC
2	FRONT LEG 	2PCS
3	REAR LEG (L&R) 	2PCS

NO	Hardware List	Q'TY
A	BOLT  Ø1/4" * 50 mm	8 PCS
B	LOCK WASHER  Ø1/4" * 11 * 1.5 mm	8 PCS
C	WASHER  Ø1/4" * 22 * 2 mm	8 PCS
D	ALLEN KEY  58 * 4mm	1PC

## STEP 1

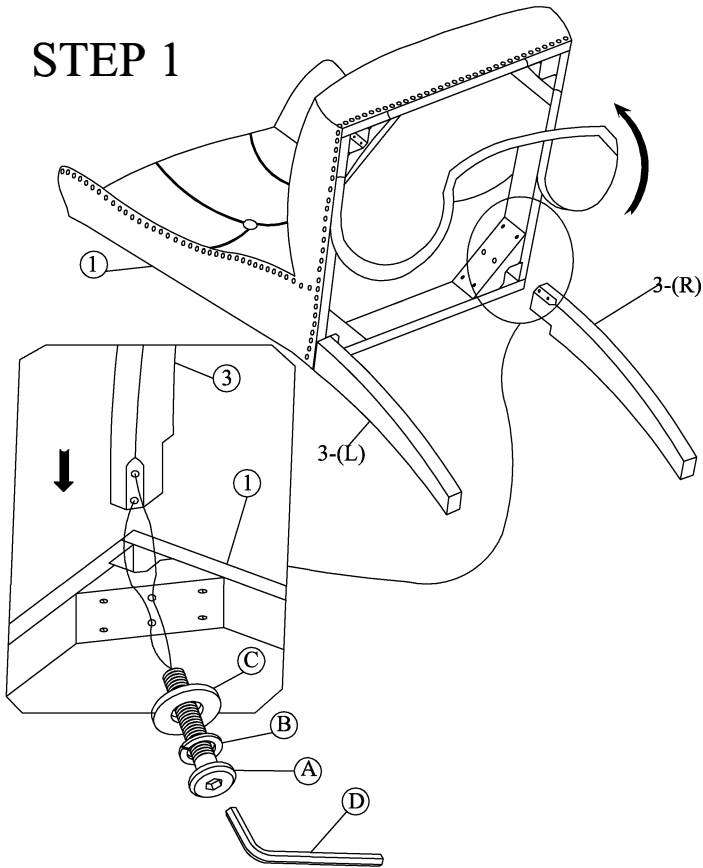

## STEP 2

Noted: the legs need to adjust 90° when assembly.

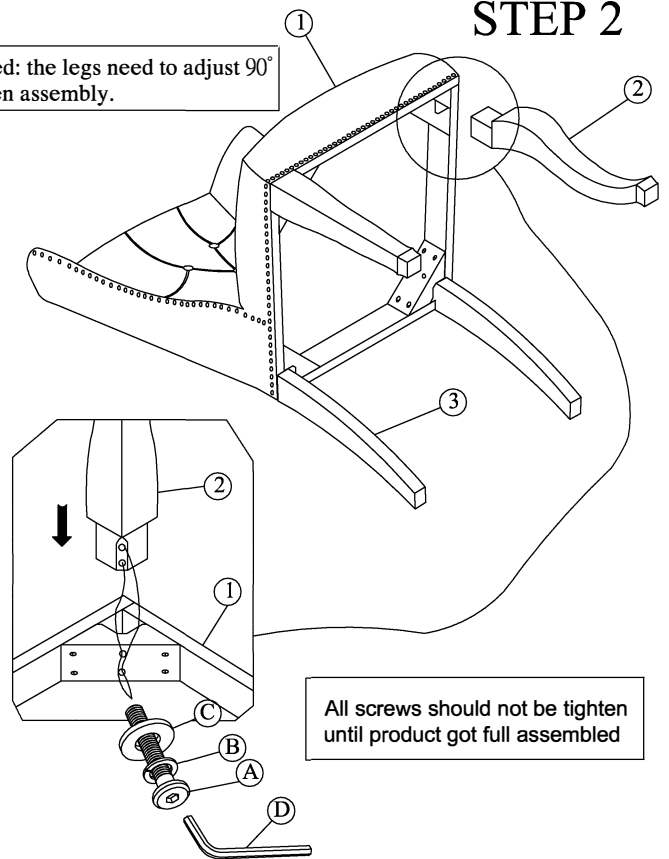



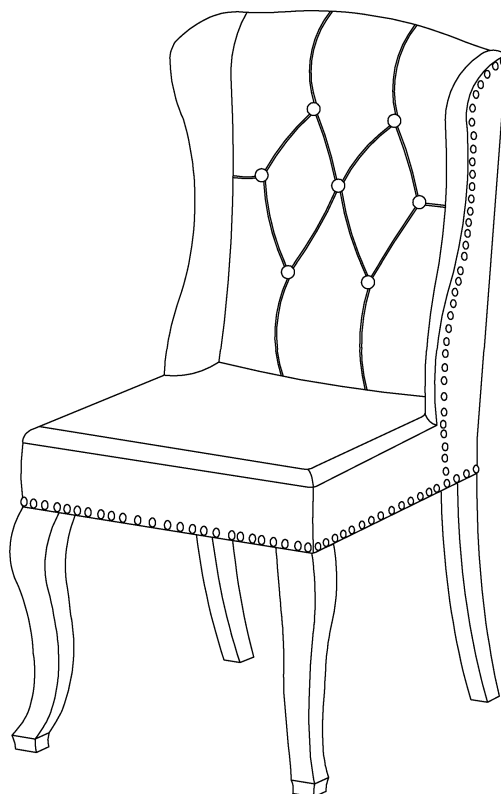

All screws should not be tighten until product got full assembled





## STEP 2



# ASSEMBLY INSTRUCTIONS

Description : Wing Bench

NO	Parts List	Q'TY
1	CHAIR FRAME WITH CUSHION SEAT 	1PC
2	FRONT LEG 	2PCS
3	REAR LEG (2L & 1R) OR (1L & 2R) 	3PCS
4	MIDDLE LEG 	1PC

NO	Hardware List	Q'TY
A	BOLT  Ø1/4" * 50 mm	12 PCS
B	LOCK WASHER  Ø1/4" * 11* 1.5 mm	12 PCS
C	WASHER  Ø1/4" * 22 *2 mm	12 PCS
D	ALLEN KEY  58 * 4mm	1PC

## STEP 1

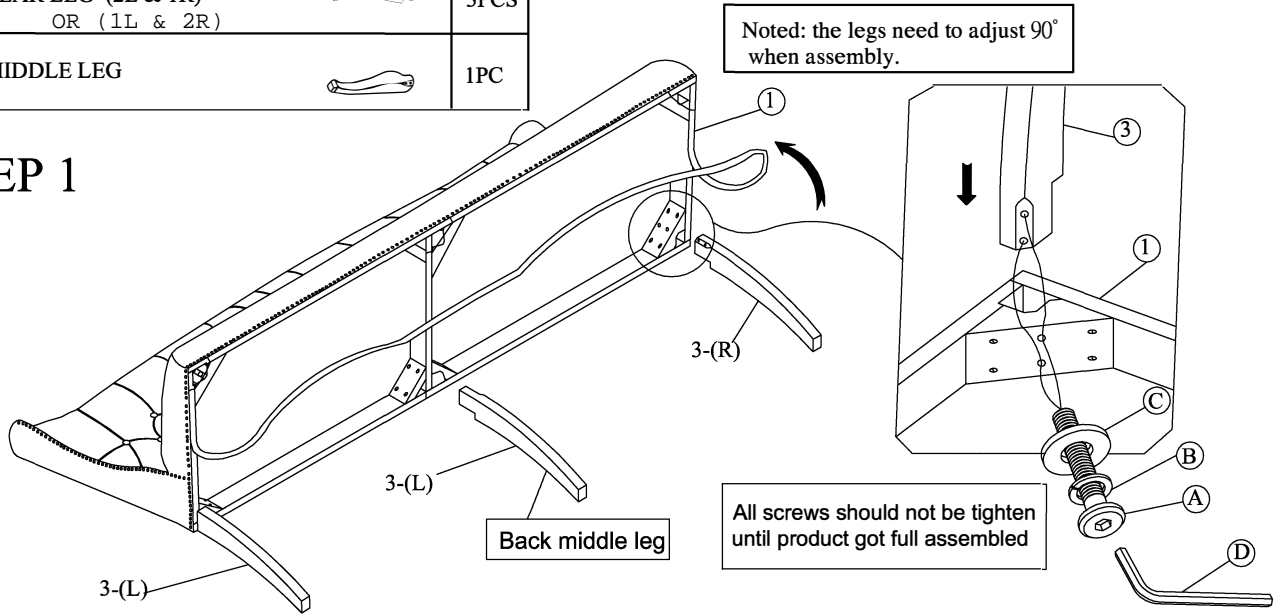

## STEP 2

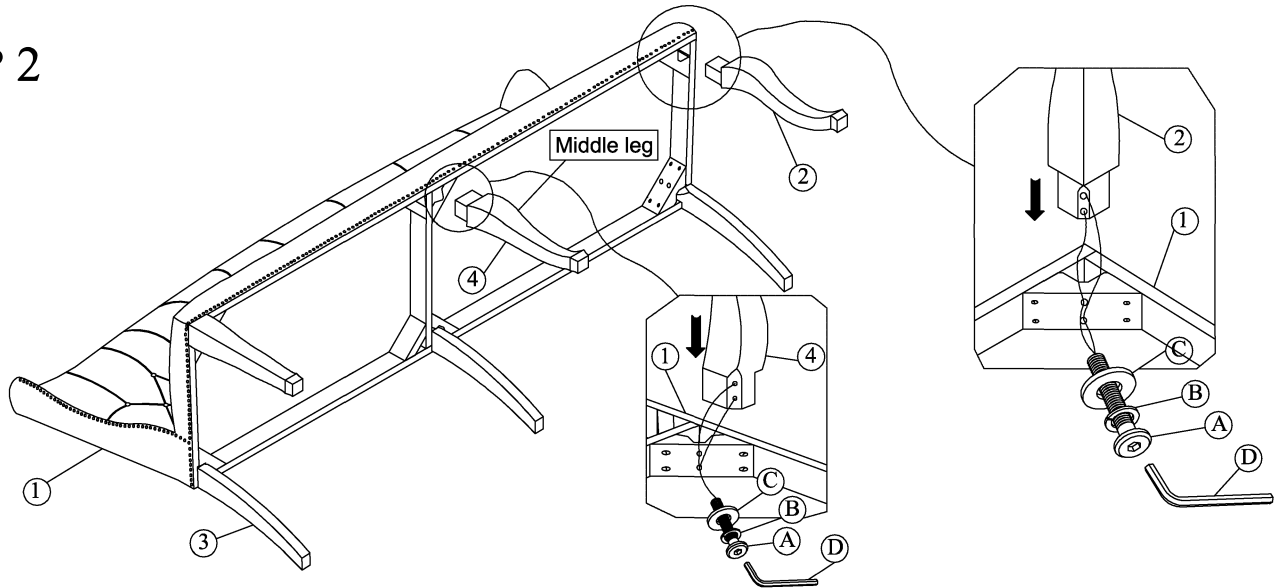

## STEP 3

