

# ASSEMBLY INSTRUCTION

Model:62070T#62071ST#62071FRM

Description:Dining Table

Thank you for purchasing this quality product, be sure to check all the packing materials carefully. When you received, please pay attention to the products, which may cause deformed during the shipment.

## step1:

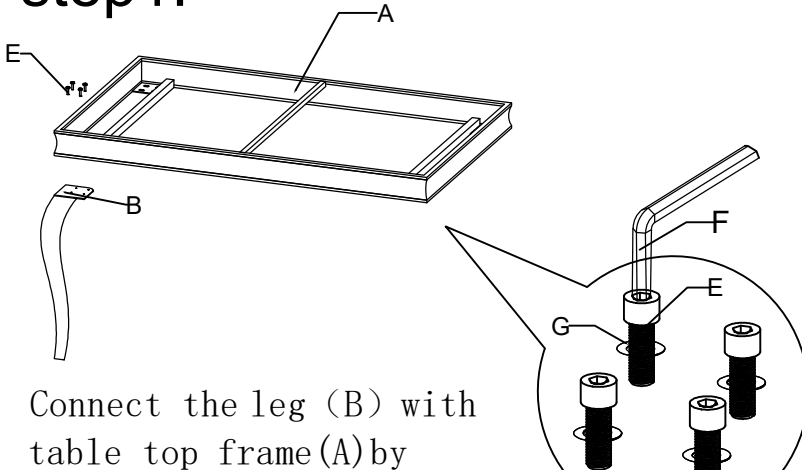

Connect the leg (B) with table top frame (A) by bolt (E) washer (G)

PART LIST			
NO.	Designation	Quantity	Diagram
A	Table top frame	1	
B	Table stainless steel legs	4	
C	Table Glass top	1	

HARDWARE LIST				
NO.	Designation	Quantity	Size	Diagram
D	Mat	4	20*20*2	
E	Bolt	16	M8*16	
F	Allen key	1	M5	
G	washer	16	Dia16mm	

## step2:

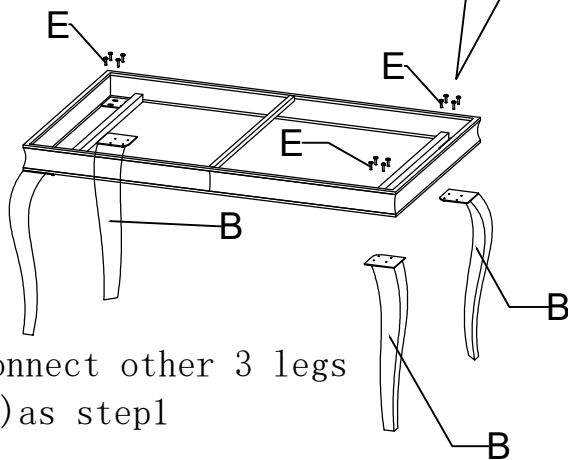

Connect other 3 legs (B) as step1

## step3:

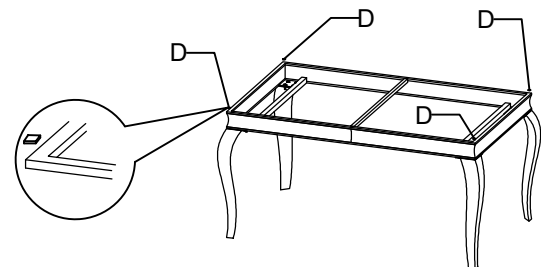

Stick the mat (D) on the 4 corners of the Table Top frame (A)

## step4:

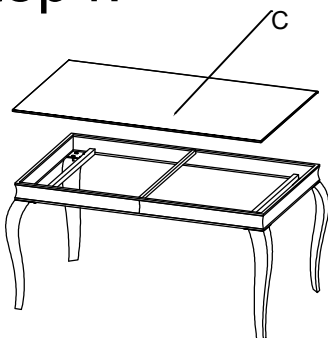

Put the Glass top (C) on the frame by aligning all the corners gently

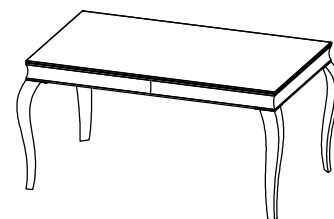

Finished