

Record Player Table

Product ID. 7AZDM

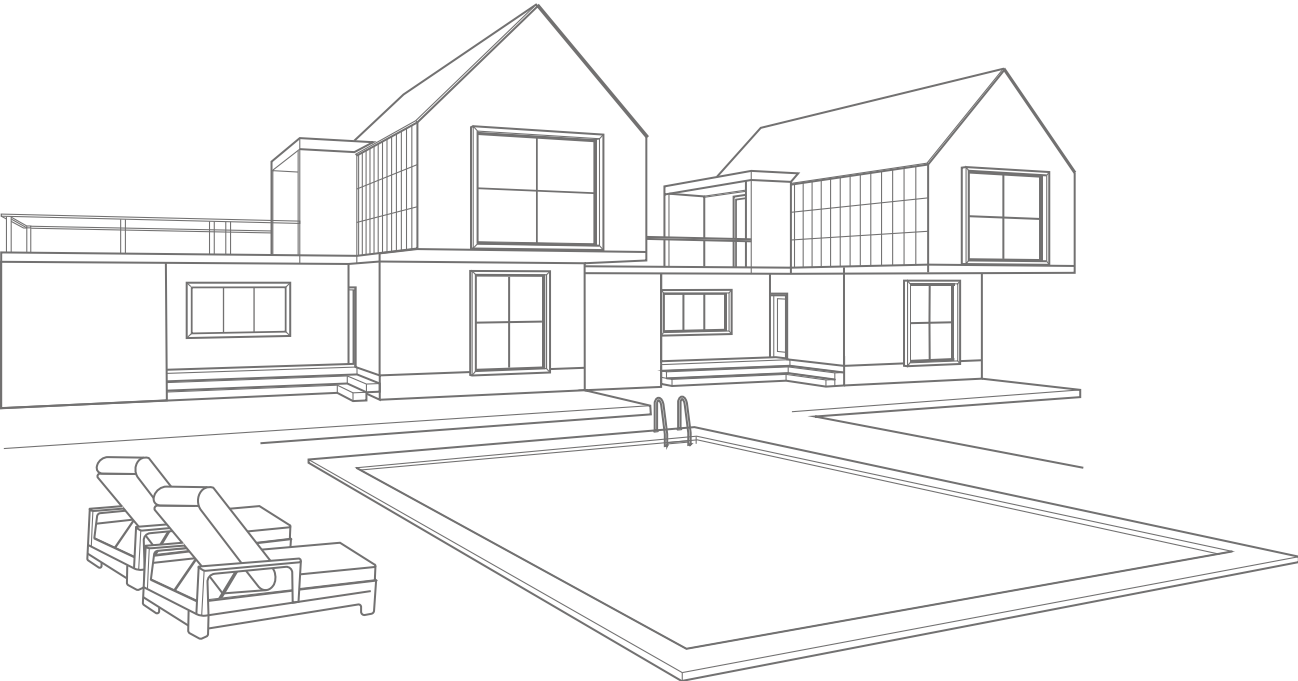

Scan for Support
support@garvee.com









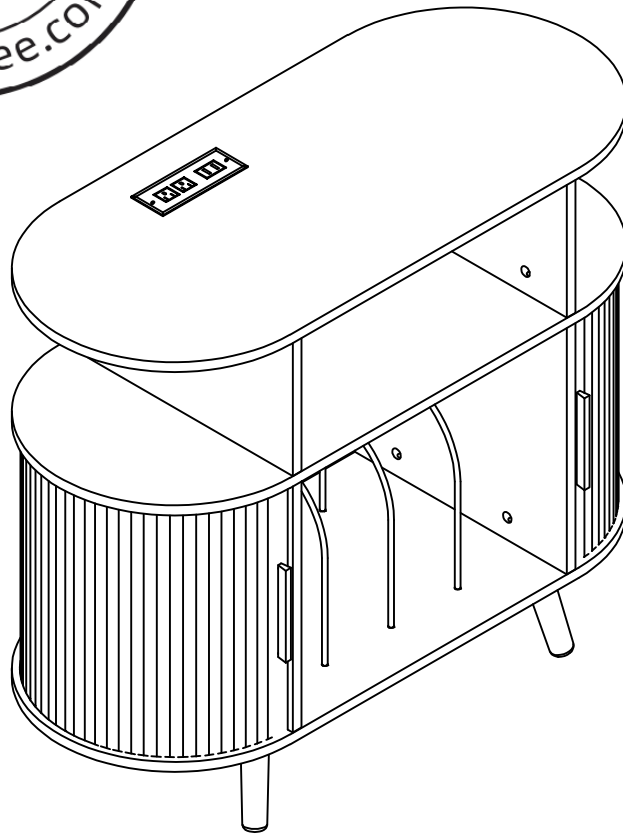

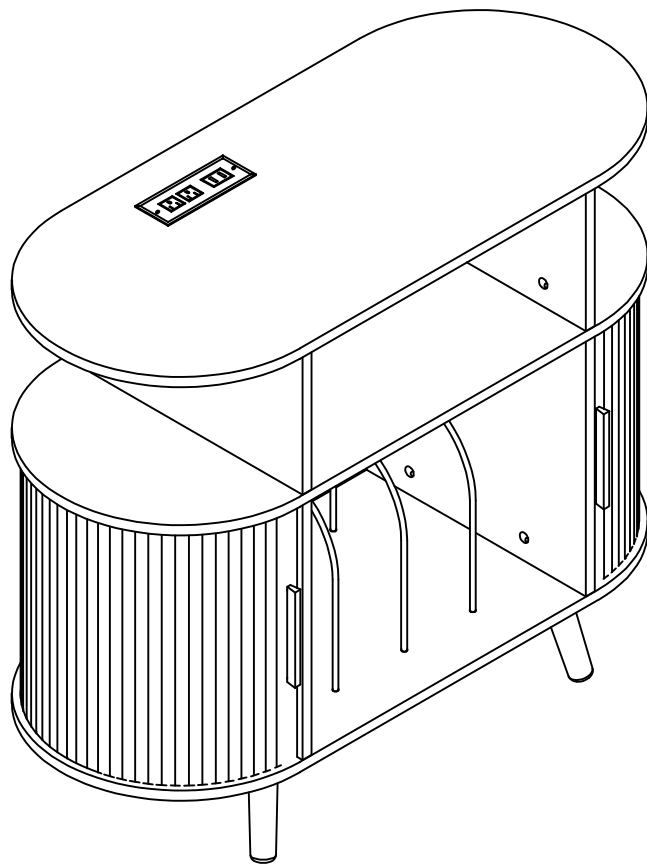
Distributed by
GARVEE.com

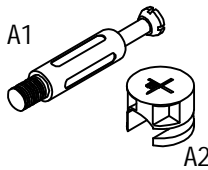
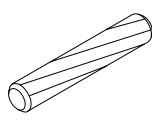
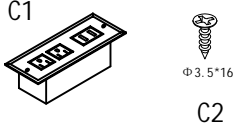
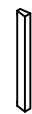
V25122761XM

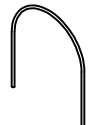
record player table



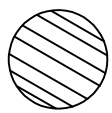
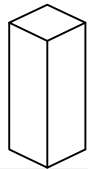

 <p>A1 A2</p>	 <p>$\Phi 8*30$</p>	 <p>C1 C2 $\Phi 3.5*16$</p>		 <p>4*10</p>
<p>A×16</p>	<p>B×16</p>	<p>C×1</p>	<p>D×2</p>	<p>E×4</p>
	 <p>4*18</p>			 <p>$\Phi 3.5*16$</p>
<p>F×3</p>	<p>G×6</p>	<p>H×4</p>	<p>J×4</p>	<p>K×20</p>
 <p>$\Phi 3*14$</p>		 <p>$\Phi 20$</p>		
<p>L×8</p>	<p>M×8</p>	<p>N×16</p>	<p>O×16</p>	

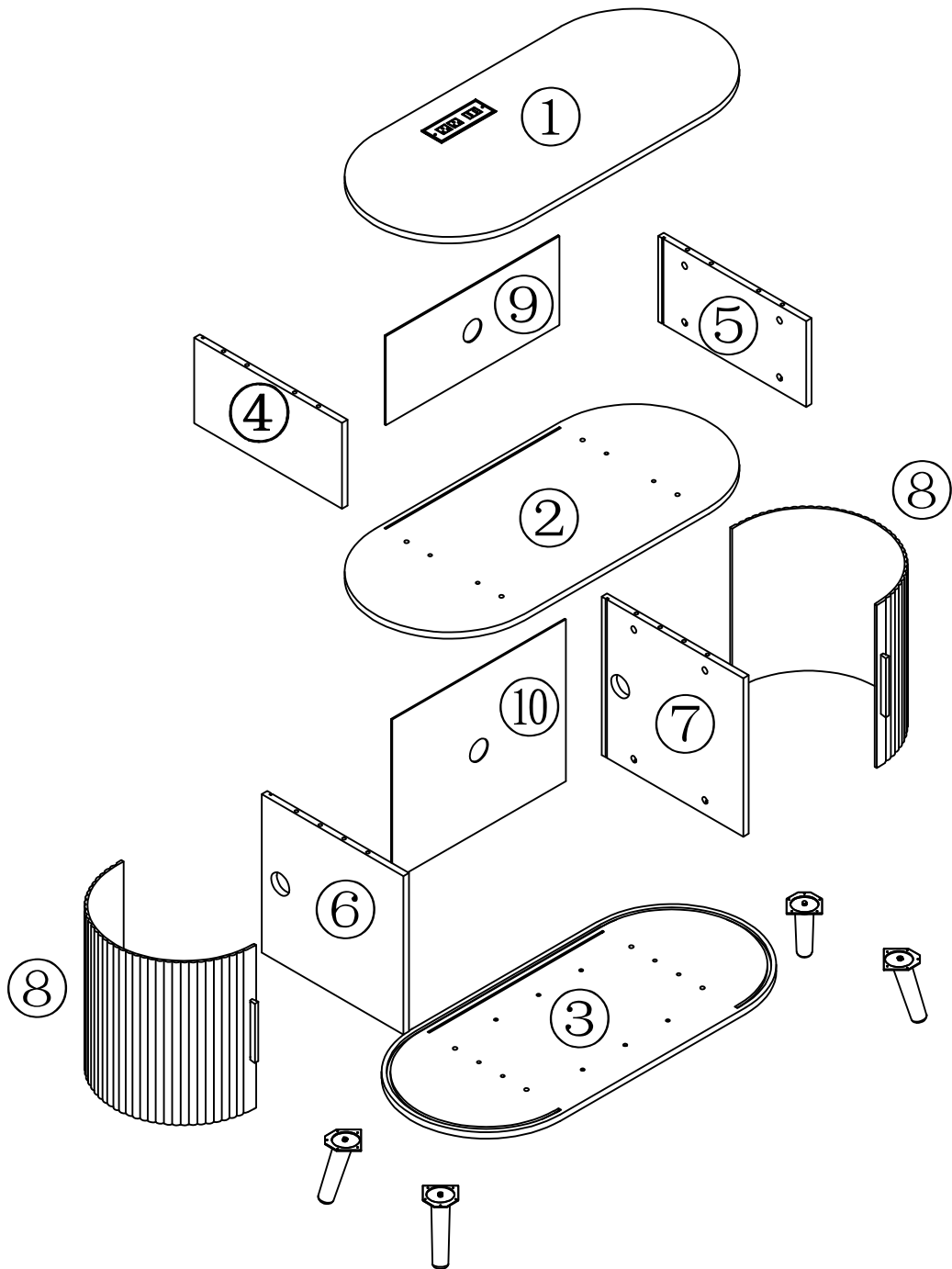

①

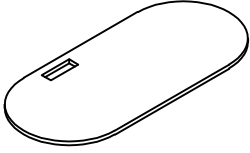

x1

②

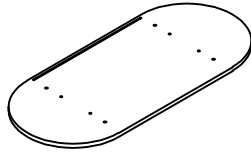

x1

③

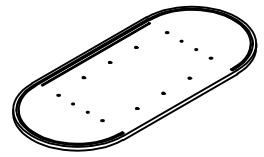

x1

④

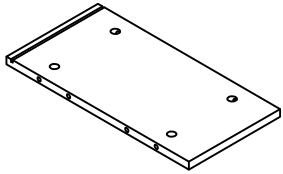

x1

⑤

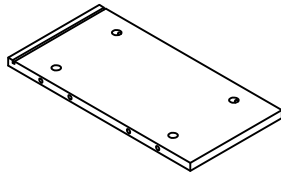

x1

⑥

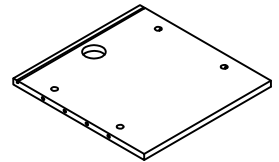

x1

⑦

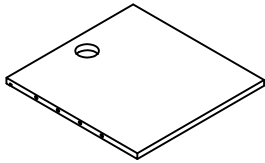

x1

⑧

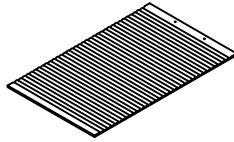

x2

⑨

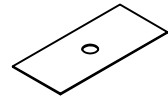

x1

⑩

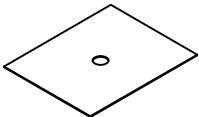

x1

1

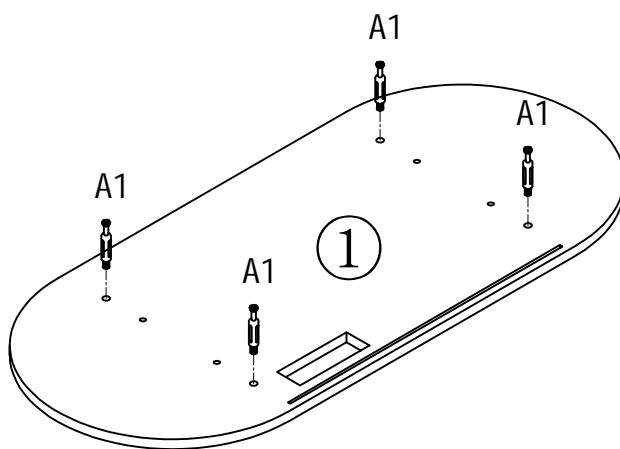

A1



4pcs

2

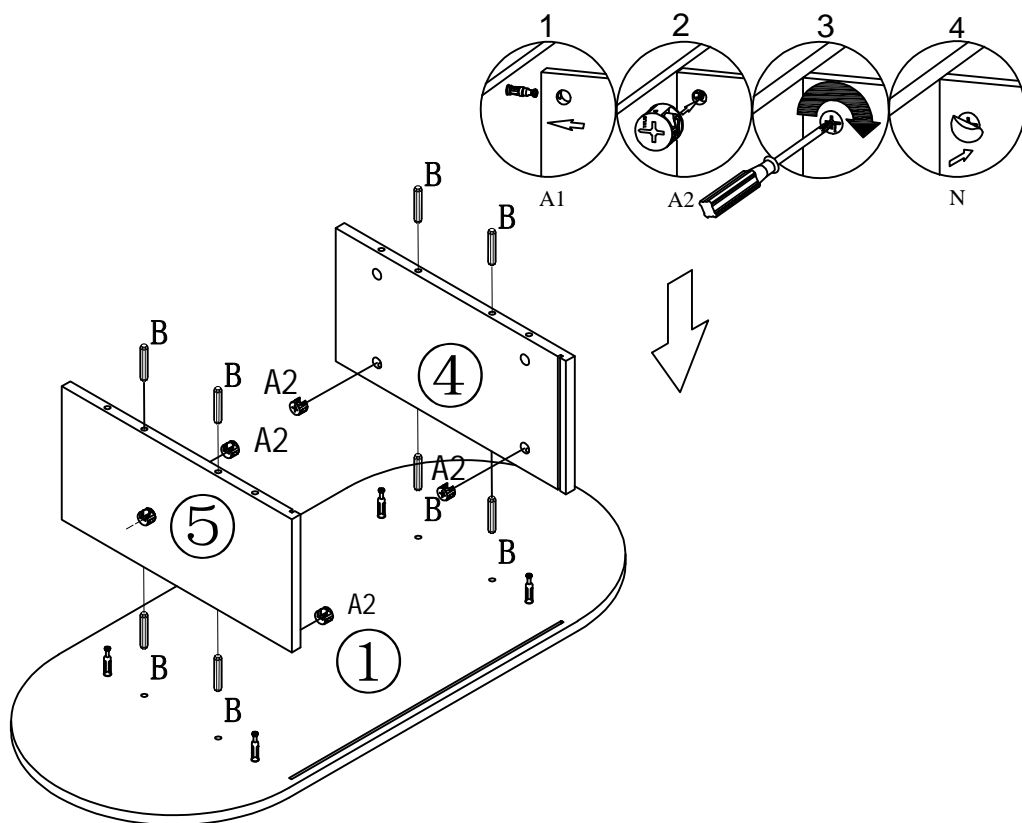

B

$\phi 8 \times 30$



8pcs

A2



4pcs

N



$\phi 20$ 4pcs

3

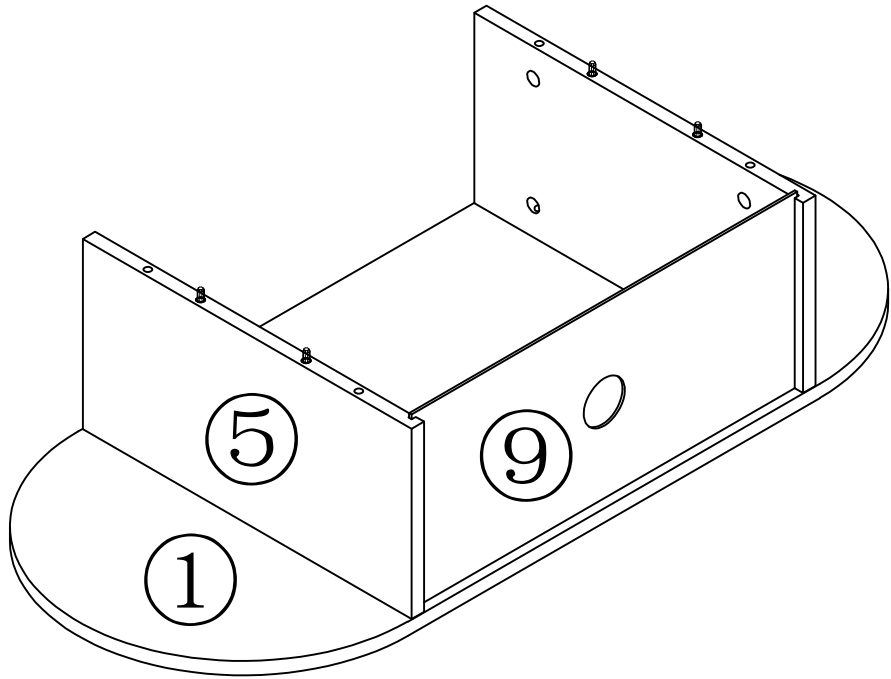
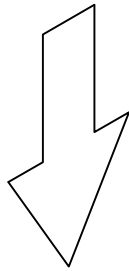
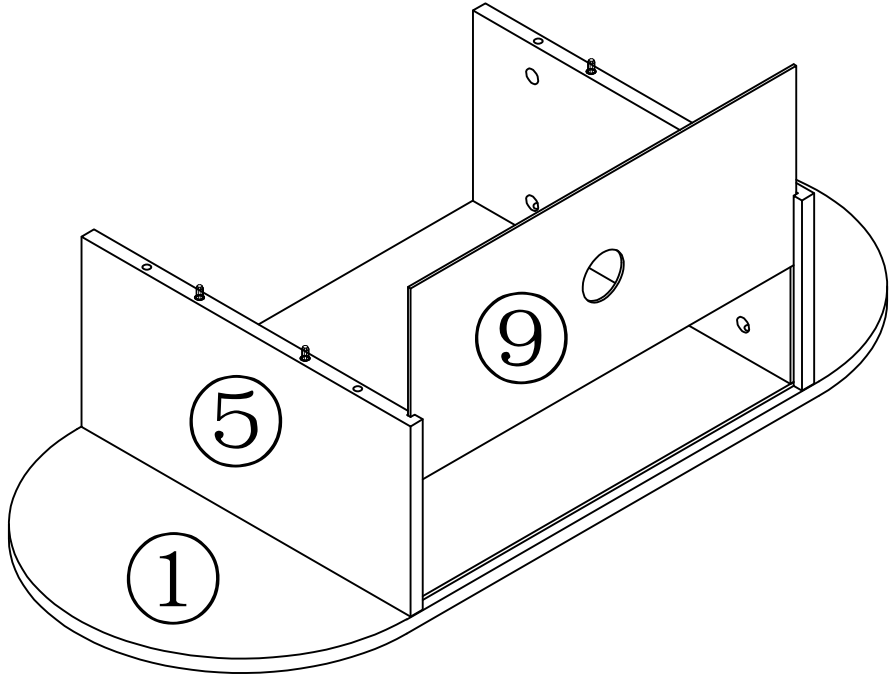

4

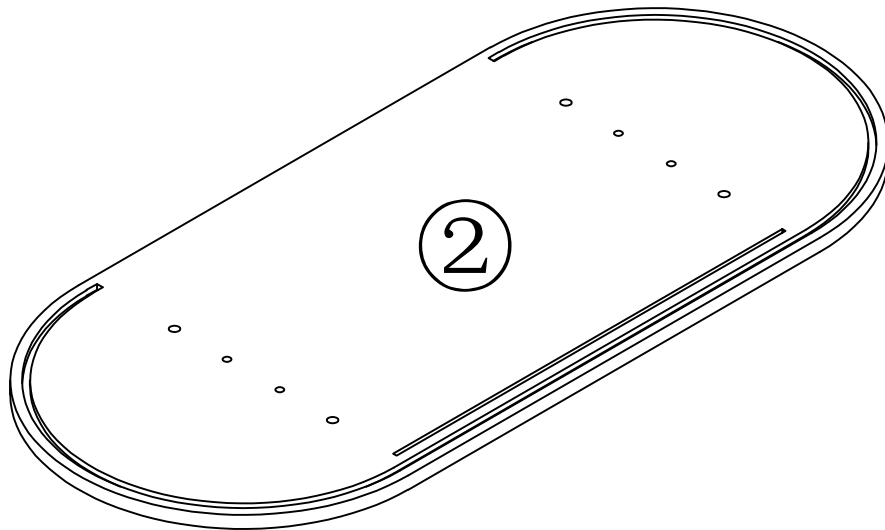
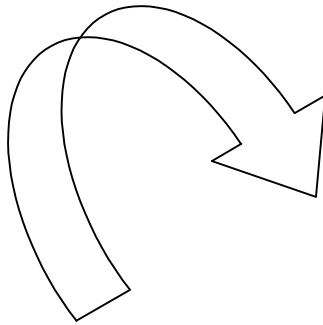
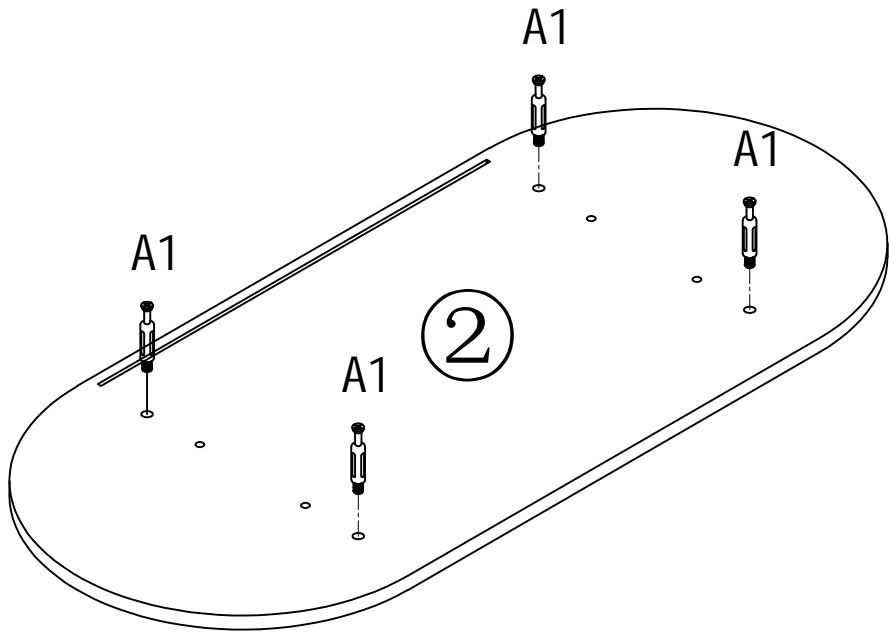

A1



4pcs

5

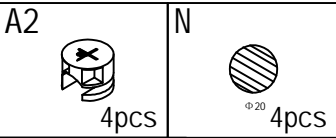
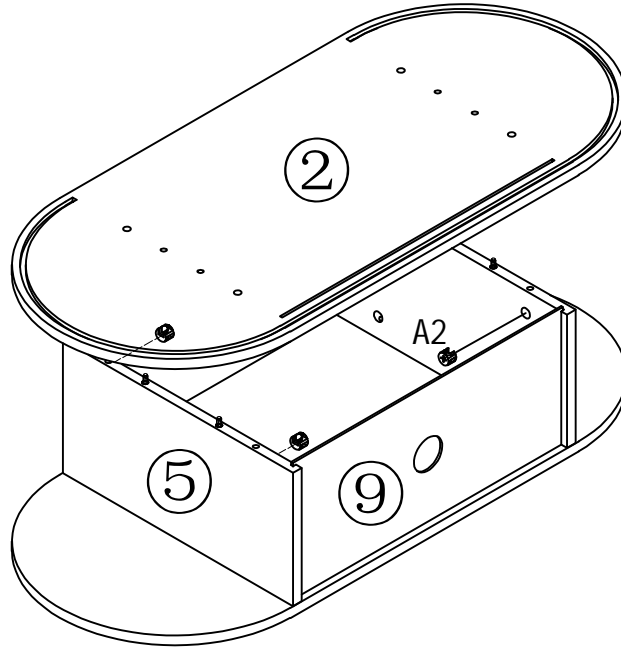
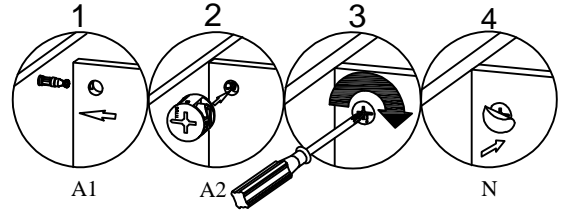

6

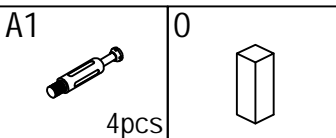
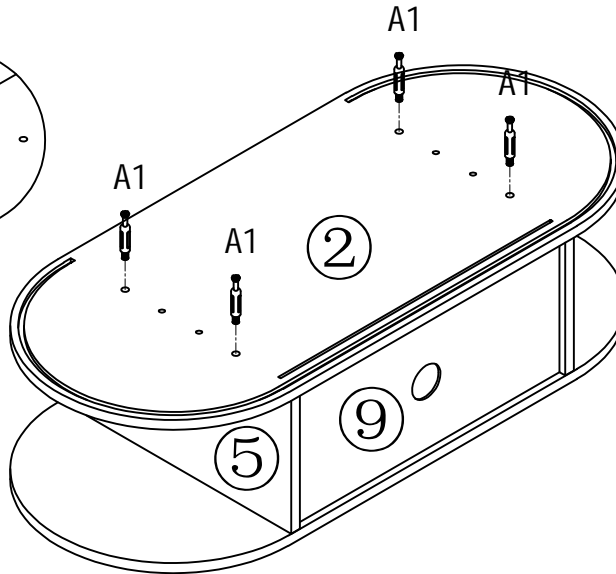
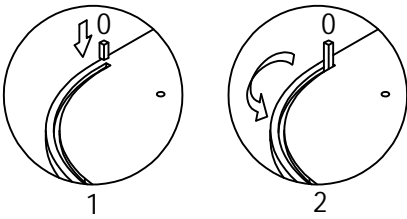

7

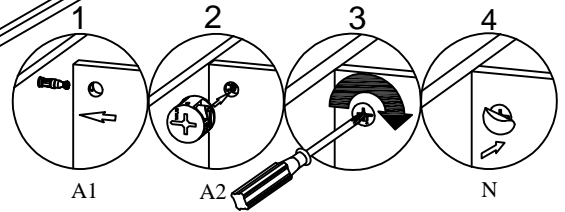
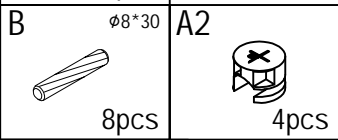
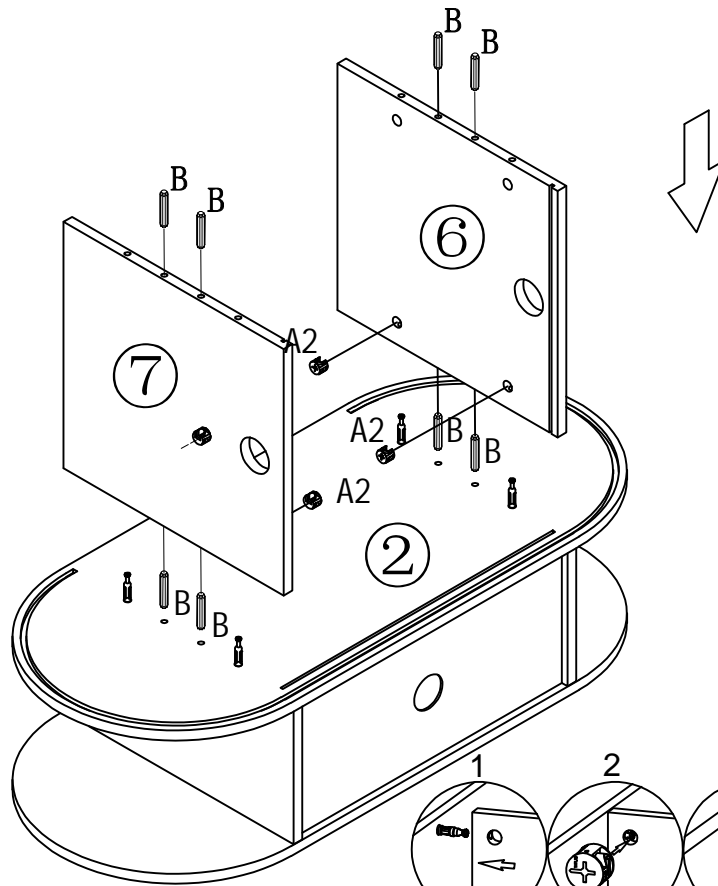

8

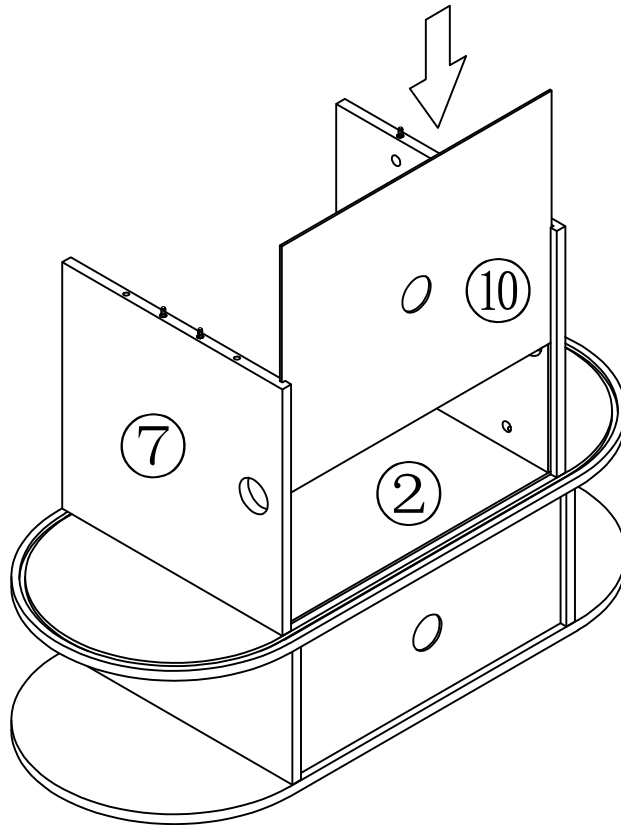

9

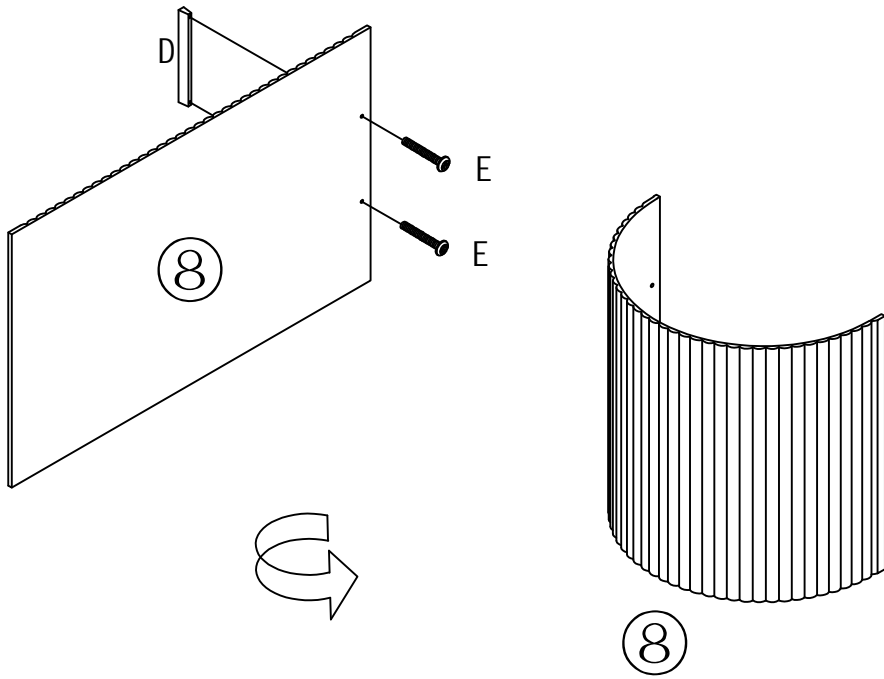

X 2

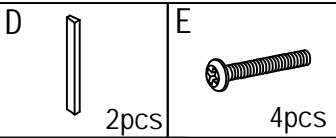

10

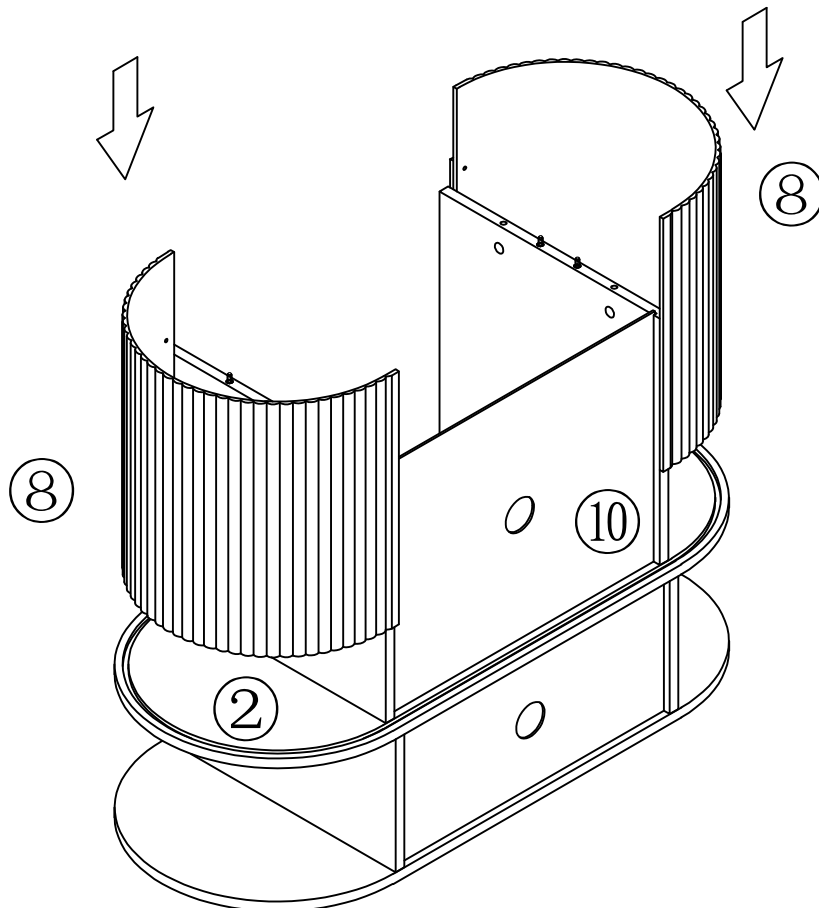

11

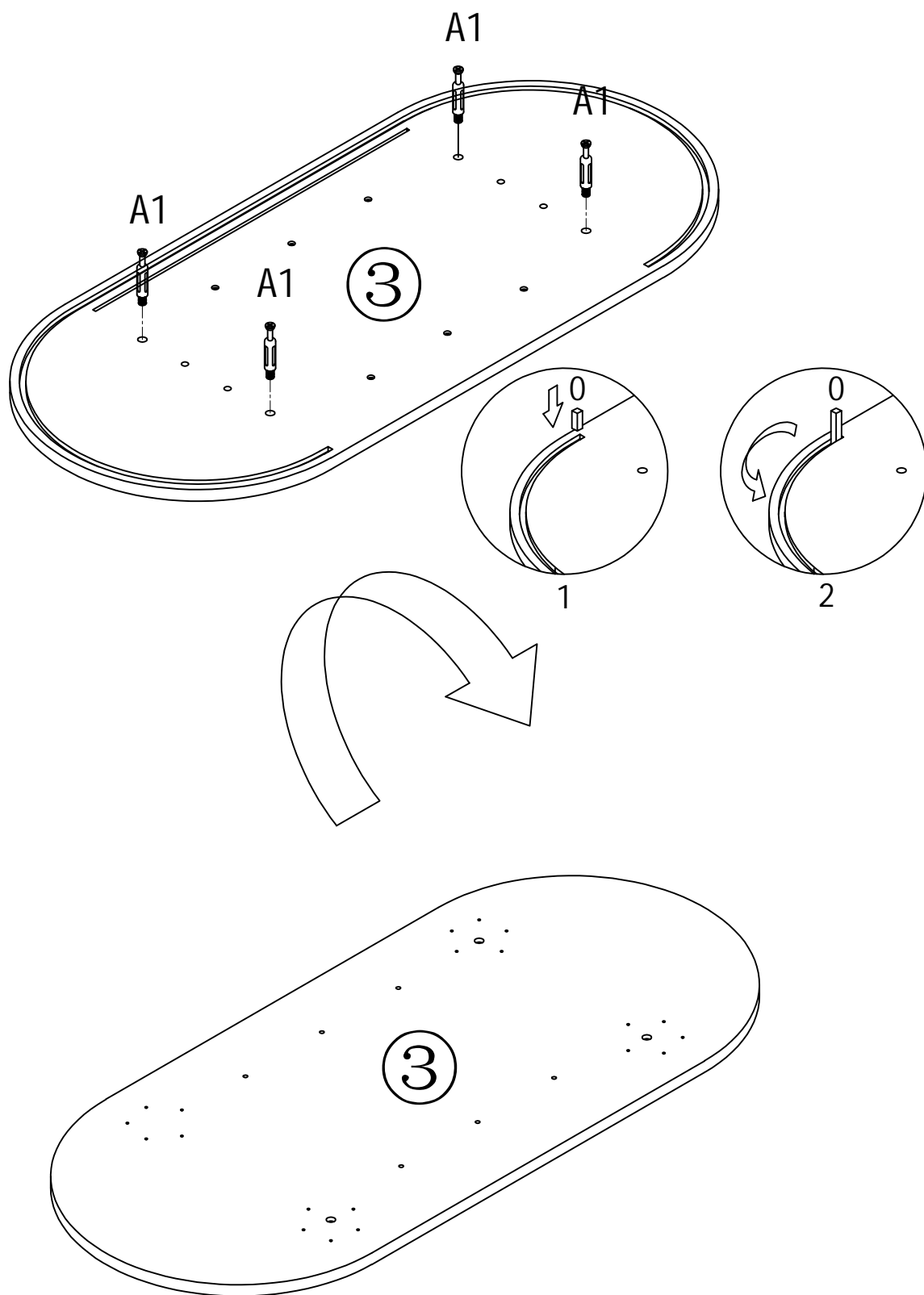

A1



4pcs

0



12

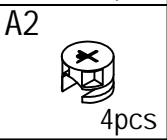
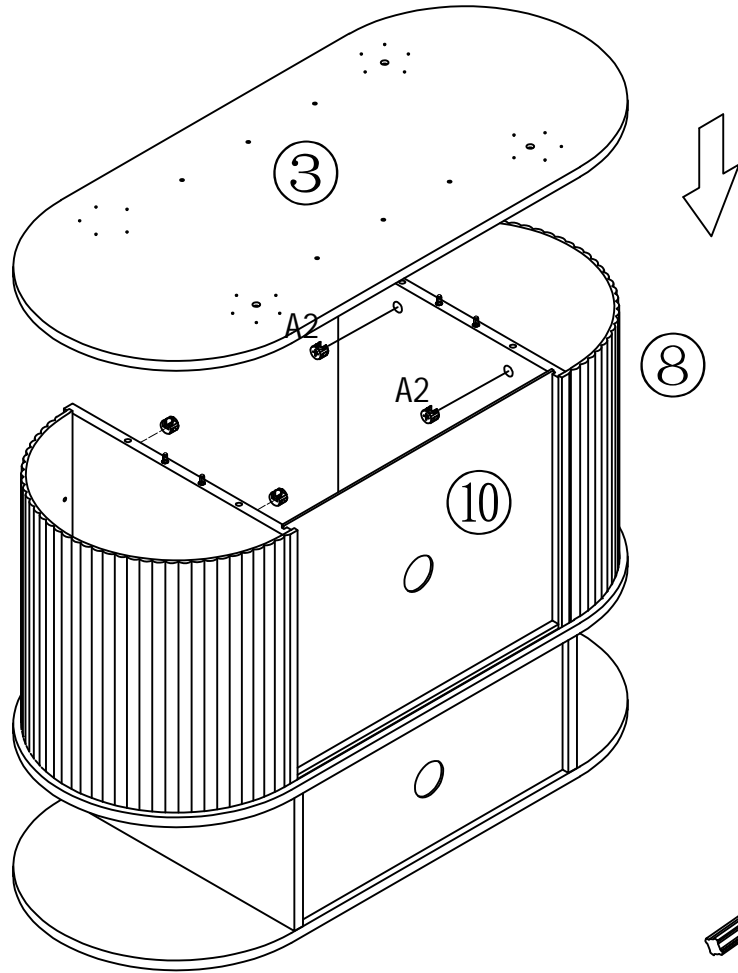

13

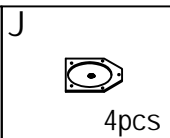
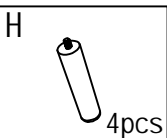
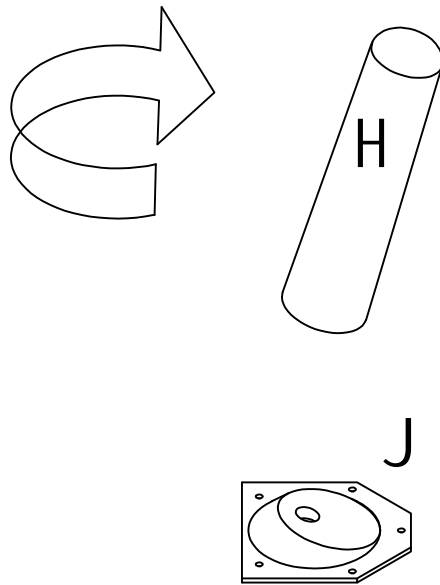

X 4

14

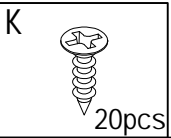
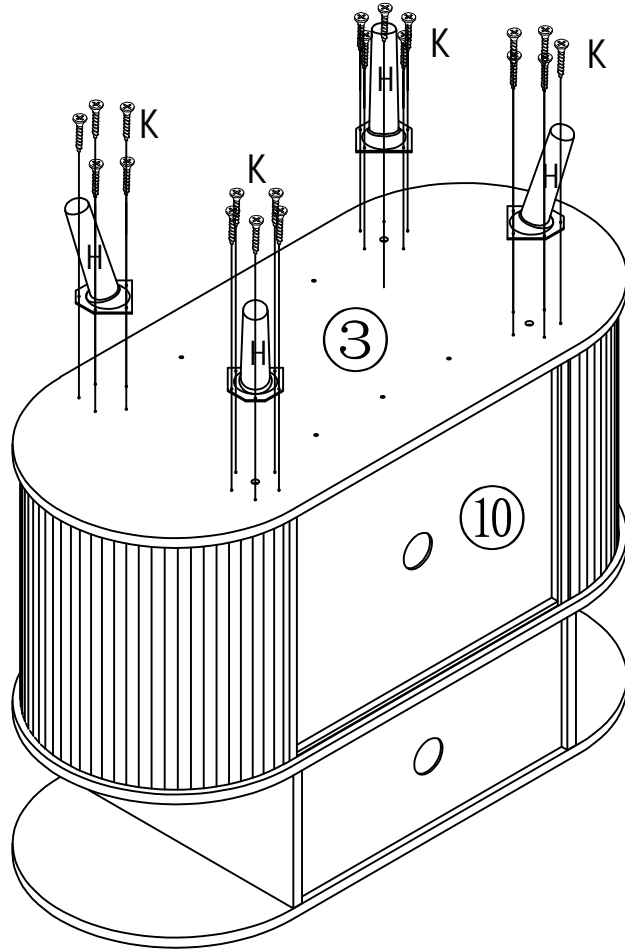

15

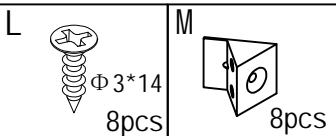
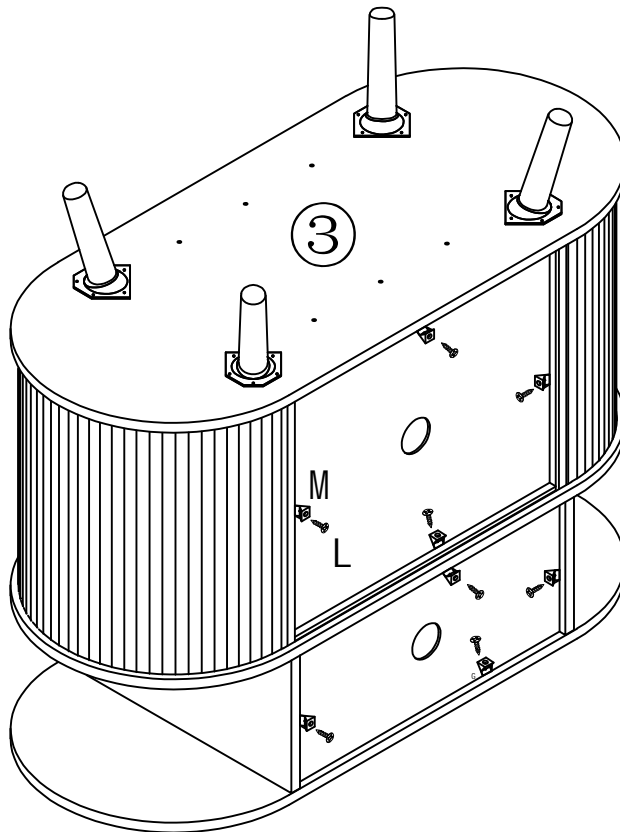

16

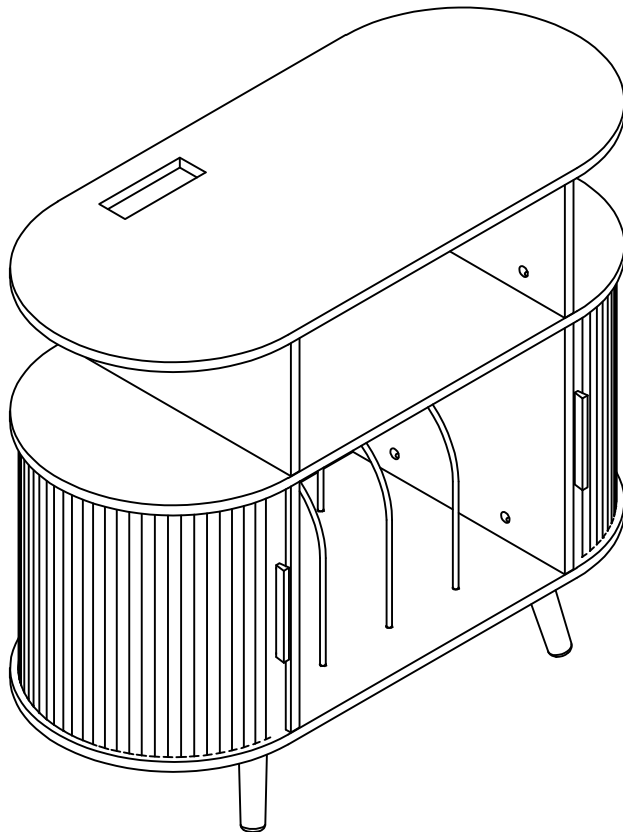
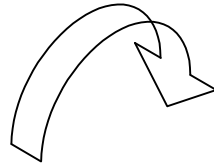
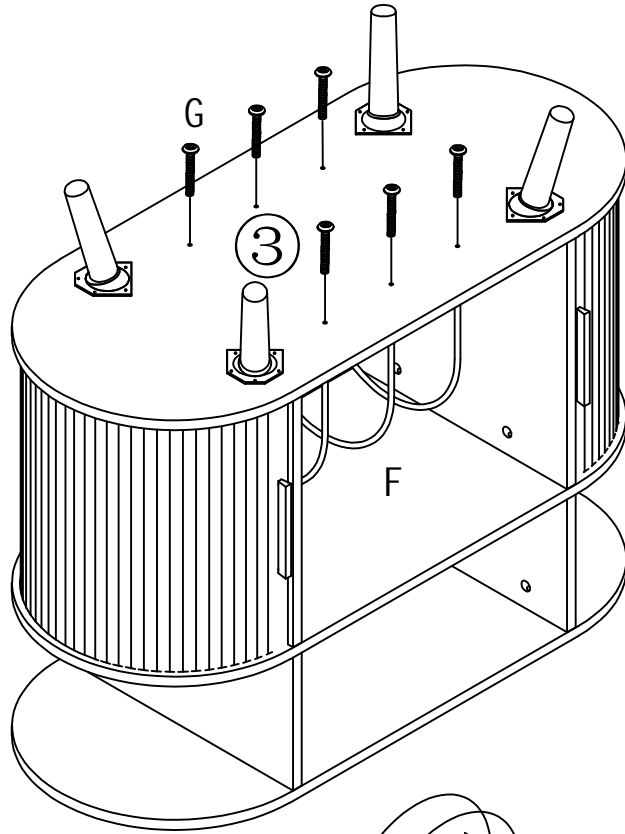

F



3pcs

G



4*18

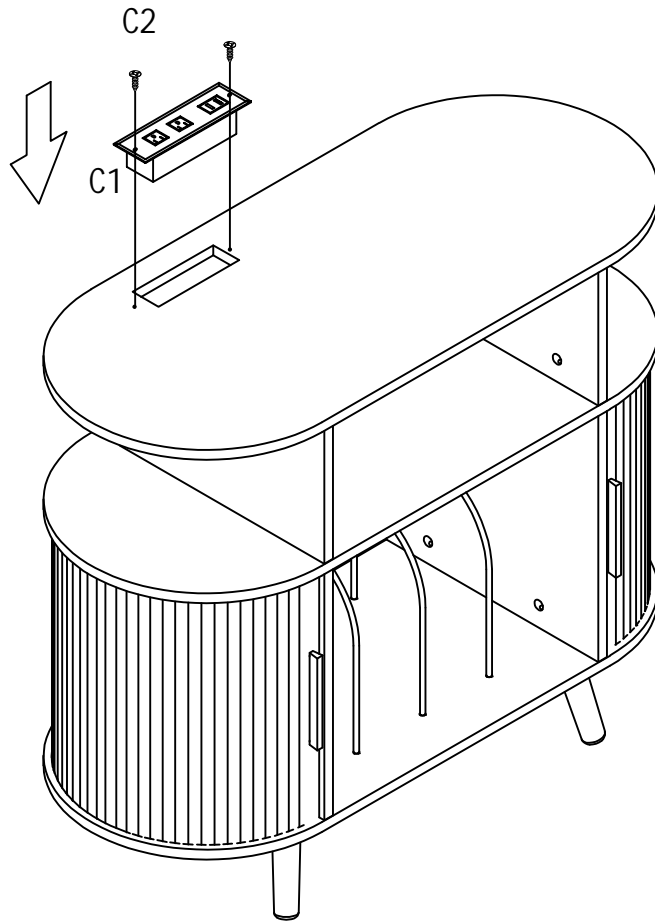

6pcs

17



C1	C2	3.5*16
 1pcs	 2pcs	

18

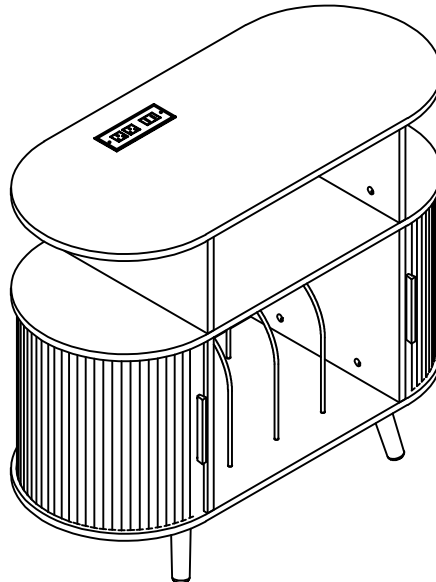

Trouble shooting:

Missing /Wrong / Broken parts and installation issues

Send email with your question, pic and order NO. to support@garvee.com

Respond within 24 hours

Issue resolved

Limited Liability & Warning

No Unauthorized Modifications/Repairs: Do not modify or attempt to repair this product unless you are an authorized technician. Unauthorized actions may create hazards and void all warranties

Misuse & Non-Compliance: We are not liable for any injury, damage, or loss resulting from:

- (a) misuse, abuse, neglect, or improper installation;
- (b) failure to follow instructions or safety precautions;
- (c) use of unauthorized parts/accessories;
- (d) unauthorized modifications/repairs;
- (e) accidents, natural disasters, or external causes.

If you doubt any step of installation or operation, stop using the product and contact authorized service or the customer support.

LIMITACIÓN DE RESPONSABILIDAD Y ADVERTENCIA

Modificaciones o Reparaciones No Autorizadas: NO modifique ni intente reparar este producto a menos que sea un técnico autorizado. Las acciones no autorizadas pueden generar riesgos y anularán todas las garantías.

Uso Indebido e Incumplimiento: No asumimos responsabilidad alguna por lesiones, daños o pérdidas que resulten de:

- (a) uso indebido, abuso, negligencia o instalación incorrecta;
- (b) incumplimiento de las instrucciones o precauciones de seguridad;
- (c) uso de piezas o accesorios no autorizados;
- (d) modificaciones o reparaciones no autorizadas;
- (e) accidentes, desastres naturales o causas externas.

Si tiene dudas sobre algún paso de la instalación o el funcionamiento, deje de usar el producto y póngase en contacto con el servicio técnico autorizado o con atención al cliente.

GARVEE
support@garvee.com