

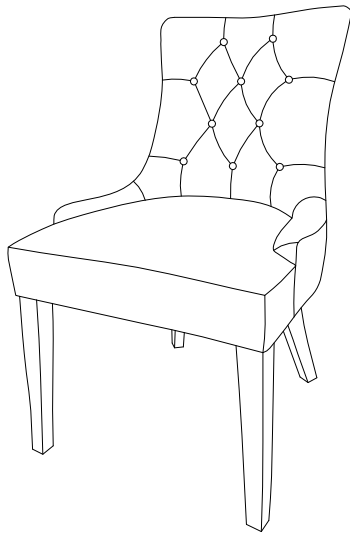

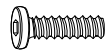

Before you start, here is some helpful advice:

1. We suggest you spend a short time reading through this leaflet and then follow the simple step by step instructions.
2. Owing to the size and weight of the dining chair, we recommend that it is assembled by two adults, on a carpeted or padded area, in the room that it is intended for. Approximate assembly time: 30 minutes.
3. Please do not use any tools other than those provided or recommended in these instructions.
4. Please do not throw away any of the packaging or instructions until you have checked all the components and hardware and the furniture is fully assembled.
5. Assemble all components loosely until advised to tighten. Depending on use, it may be necessary to tighten the components from time to time, so please save the tools that have been provided.
6. Please keep all pieces out of reach of small children.



Hardware:

A		Bolt M8x57mm	x 8
B		Spring Washer M8	x 8
C		Flat Washer M8	x 8
D		Allen Wrench	x 1

Component:

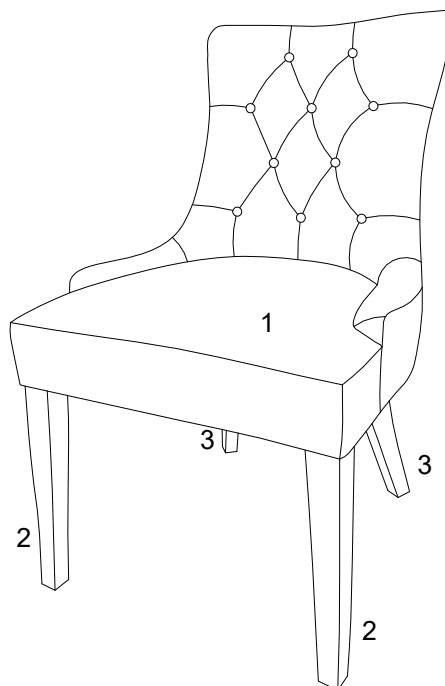

1 Chair Body x1

2 Front Leg x2

3 Back Leg x2

STEP 1:

Please put the **Chair Body (1)** upside down on a carpeted or padded area.
Then open the zipper on the bottom of **Chair Body (1)**, to make the inside of the **Chair Body(1)** fully visible.
Please find **Legs (2&3)** package and hardware package inside of the **Seat Chair Body (1)**.
Insert 1 piece of **Front Leg (2)** into the left upper hole on bottom of the **Chair Body (1)** as shown.
Attach by using 2 pieces of **Bolt (A)**, 2 pieces of **Spring Washer (B)** and 2 pieces of **Flat Washer (C)**.
Repeat the same steps for the remaining **Front Leg (2)** and **Back Leg (3)**.
Do not fully tighten **Bolts (B)** for either leg.

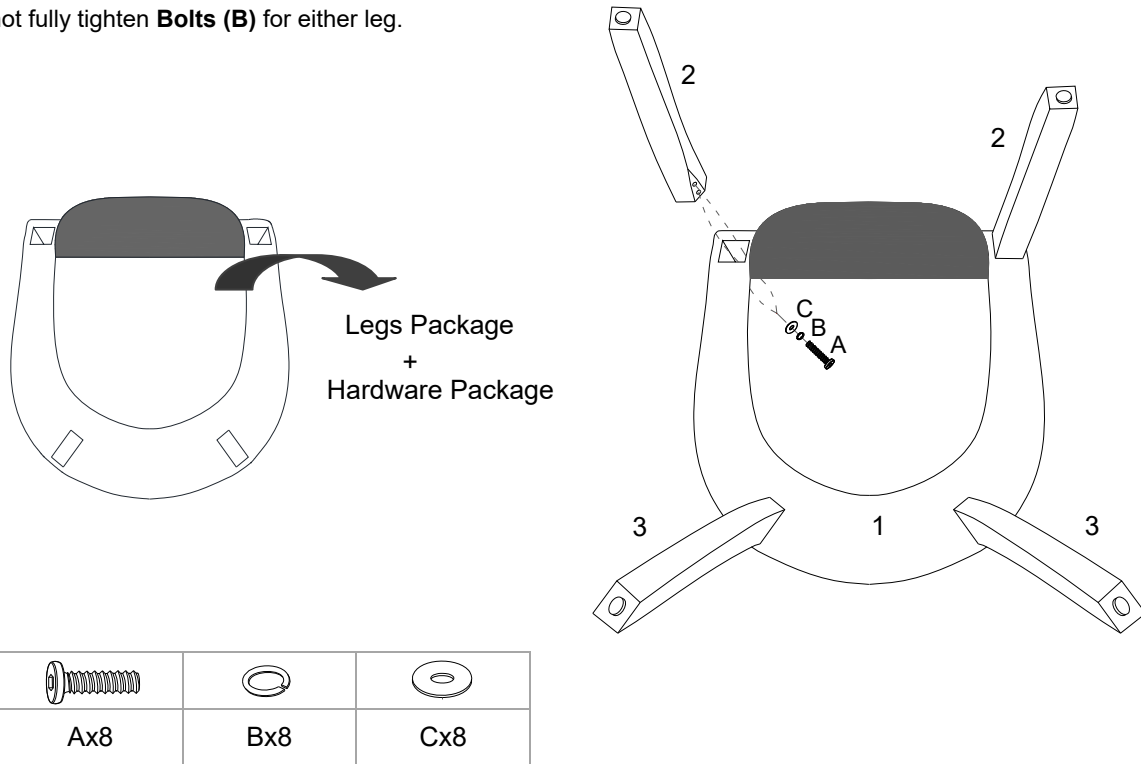

STEP 2:

Carefully turn over the dining chair.
Close the zipper on bottom of the **Chair Body (1)**.
Please put a heavy object or seat one adult on top of the **Chair Body (1)** to pressure the chair for leveling.
Fully tighten all **Bolts (A)** with **Allen Wrench (D)**.

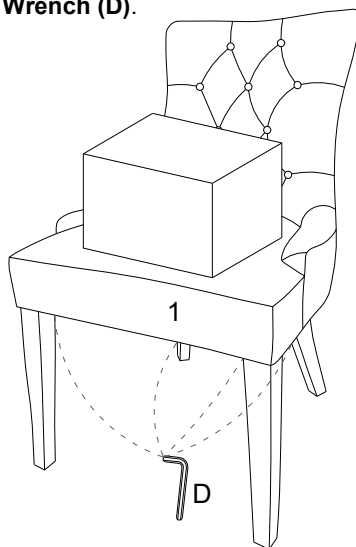

Assembly is completed. The chair is ready to use now!

