

Thank you for purchasing our products. Please read the instructions carefully before installation and keep it in a safe place for future reference.

If you need any assistance or support, please feel free to contact our customer support team.

1. There are many components and accessories in the package. Each component and accessory is labeled with a letter or a number, check carefully before using any of them. Keep them away from children to prevent accidents.
2. Please install the product on a clean and soft underlay (such as carpet or cardboard) to avoid scratching or damaging the surface of the product.
3. The main components of the product are relatively heavy. Please pay attention to safety during installation.
4. The product is not stable during installation. Please do not move it randomly before it is completely installed.
5. If you have any questions during installation, please contact the customer service in time.

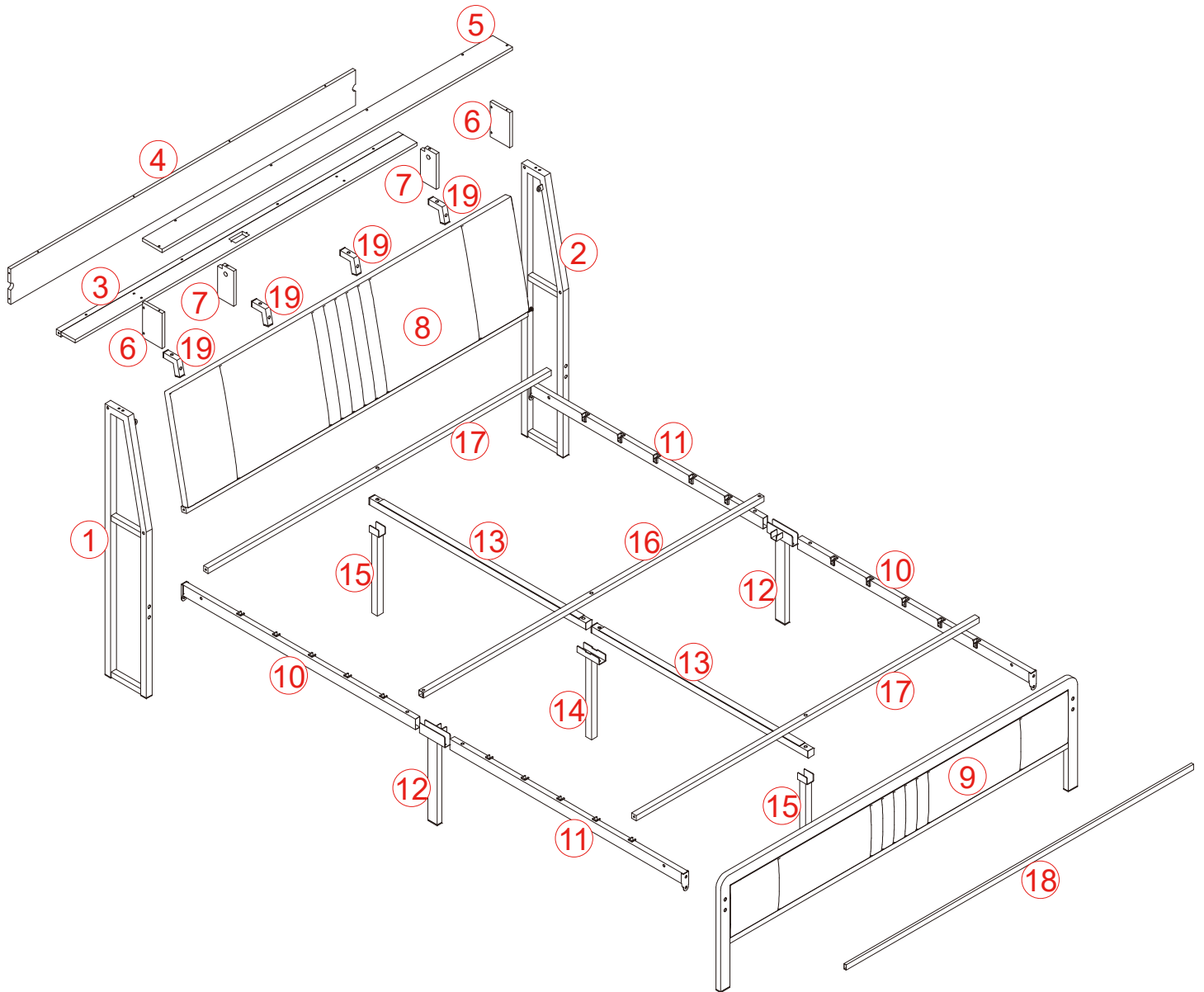

***PLEASE BE SURE TO FOLLOW THE INSTALLATION STEPS IN THE MANUAL TO AVOID UNNECESSARY LOSSES CAUSED BY IMPROPER INSTALLATION.**

***IF YOU NEED FURTHER ASSISTANCE, PLEASE CONTACT THE CUSTOMER SERVICE ONLINE.**





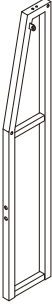
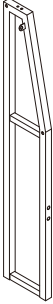
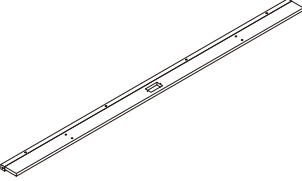
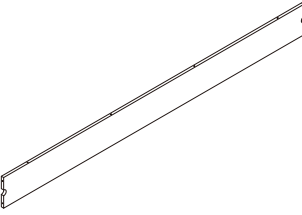
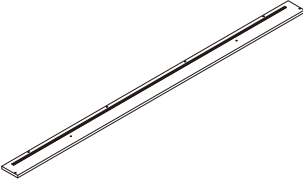
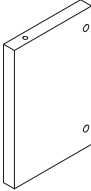
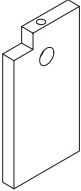
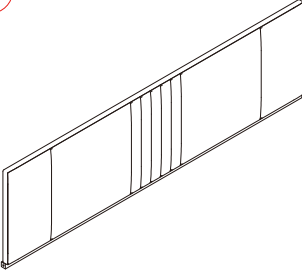
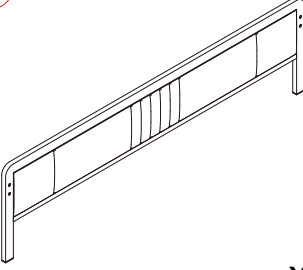
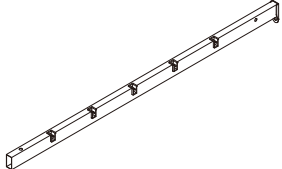
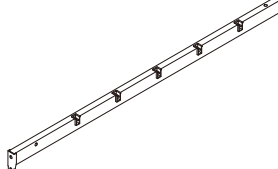
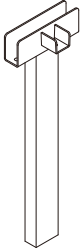
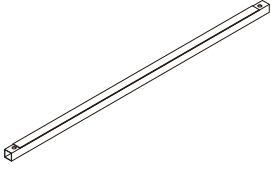
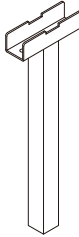

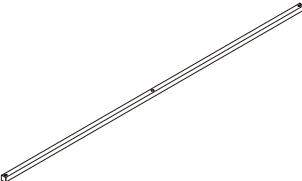
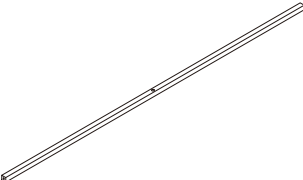
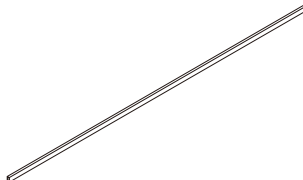
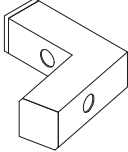
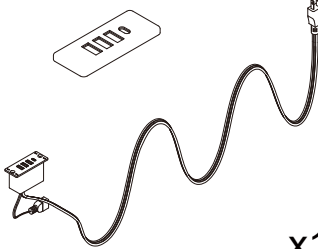
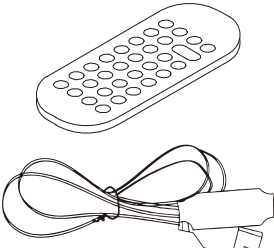
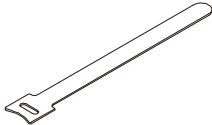
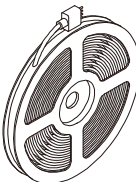



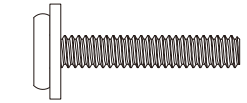
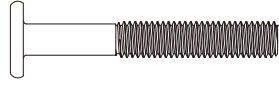
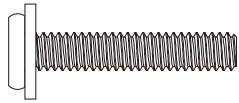

PARTS LIST

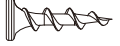
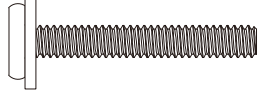
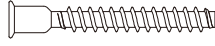
P.4

 <p>1</p> <p>x1</p>	 <p>2</p> <p>x1</p>	 <p>3</p> <p>x1</p>	 <p>4</p> <p>x1</p>
 <p>5</p> <p>x1</p>	 <p>6</p> <p>x2</p>	 <p>7</p> <p>x2</p>	 <p>8</p> <p>x1</p>
 <p>9</p> <p>x1</p>	 <p>10</p> <p>x2</p>	 <p>11</p> <p>x2</p>	 <p>12</p> <p>x2</p>
 <p>13</p> <p>x2</p>	 <p>14</p> <p>x1</p>	 <p>15</p> <p>x2</p>	 <p>16</p> <p>x1</p>
 <p>17</p> <p>x2</p>	 <p>18</p> <p>x10</p>	 <p>19</p> <p>x4</p>	 <p>20</p> <p>x1</p>
 <p>21</p> <p>x1</p>	 <p>22</p> <p>x1</p>	 <p>23</p> <p>x1</p>	

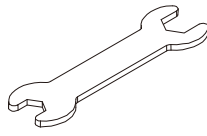
HARDWARE LIST

P.5

A 1/4x10  x2	B 1/4x30  x10	C 5/16x55  x7	D 5/16x40  x10	E 5/16  x4
F M3x10  x2	G 1/4x45  x8	H M5x35  x20	I Ø6x30  x2	J Ø6x35  x2
K Ø15x10  x2	L 1/4X5/16  x1	M M4x100  x1	N M4  x1	O M3  x1

1

 G x 4

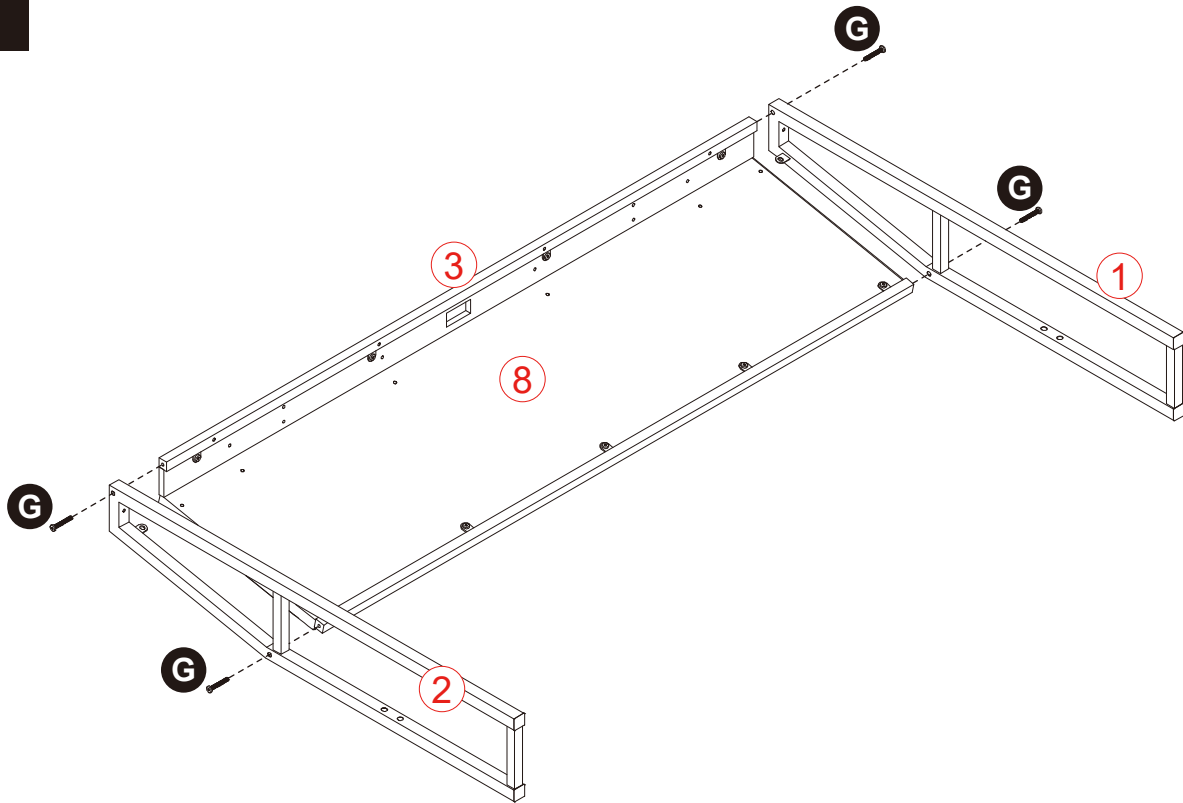

2

 B x 8

 A x 2

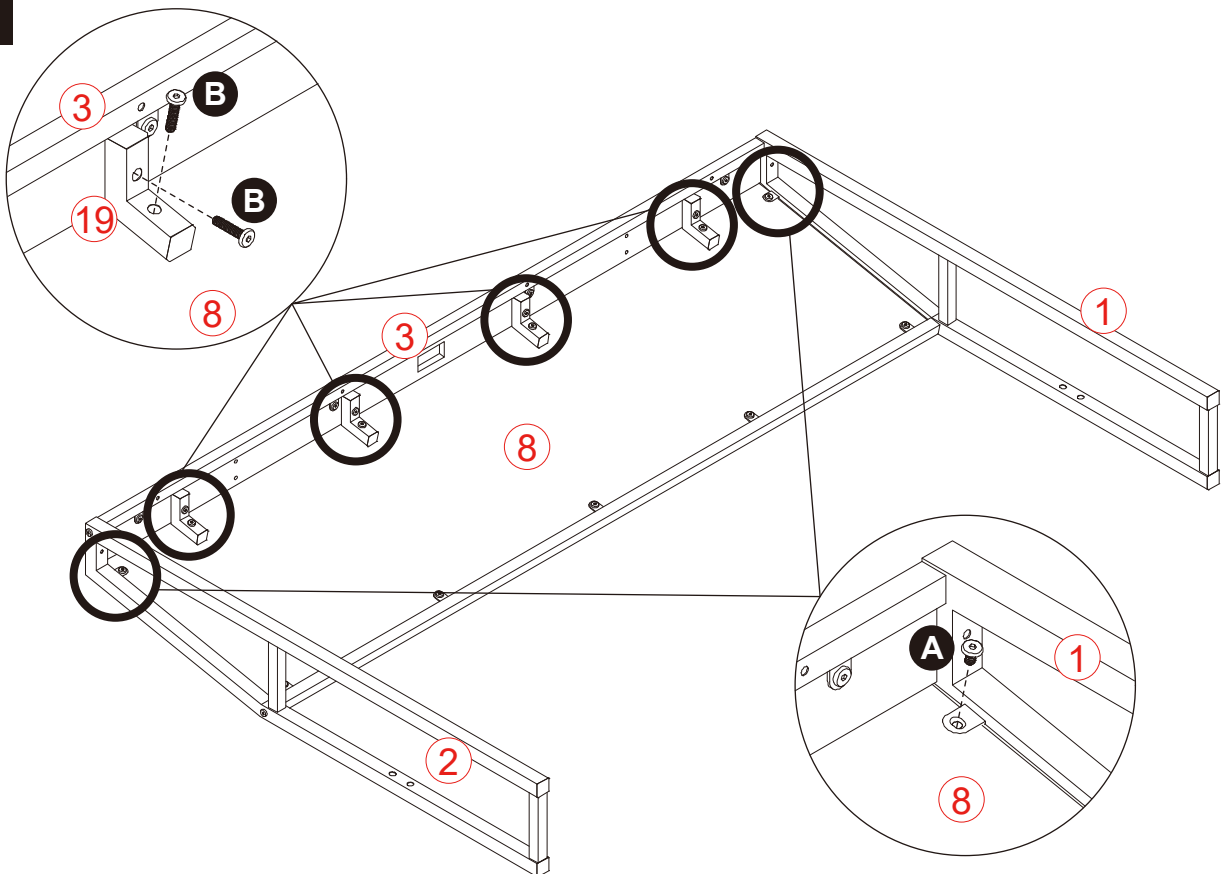

3

 H x 4

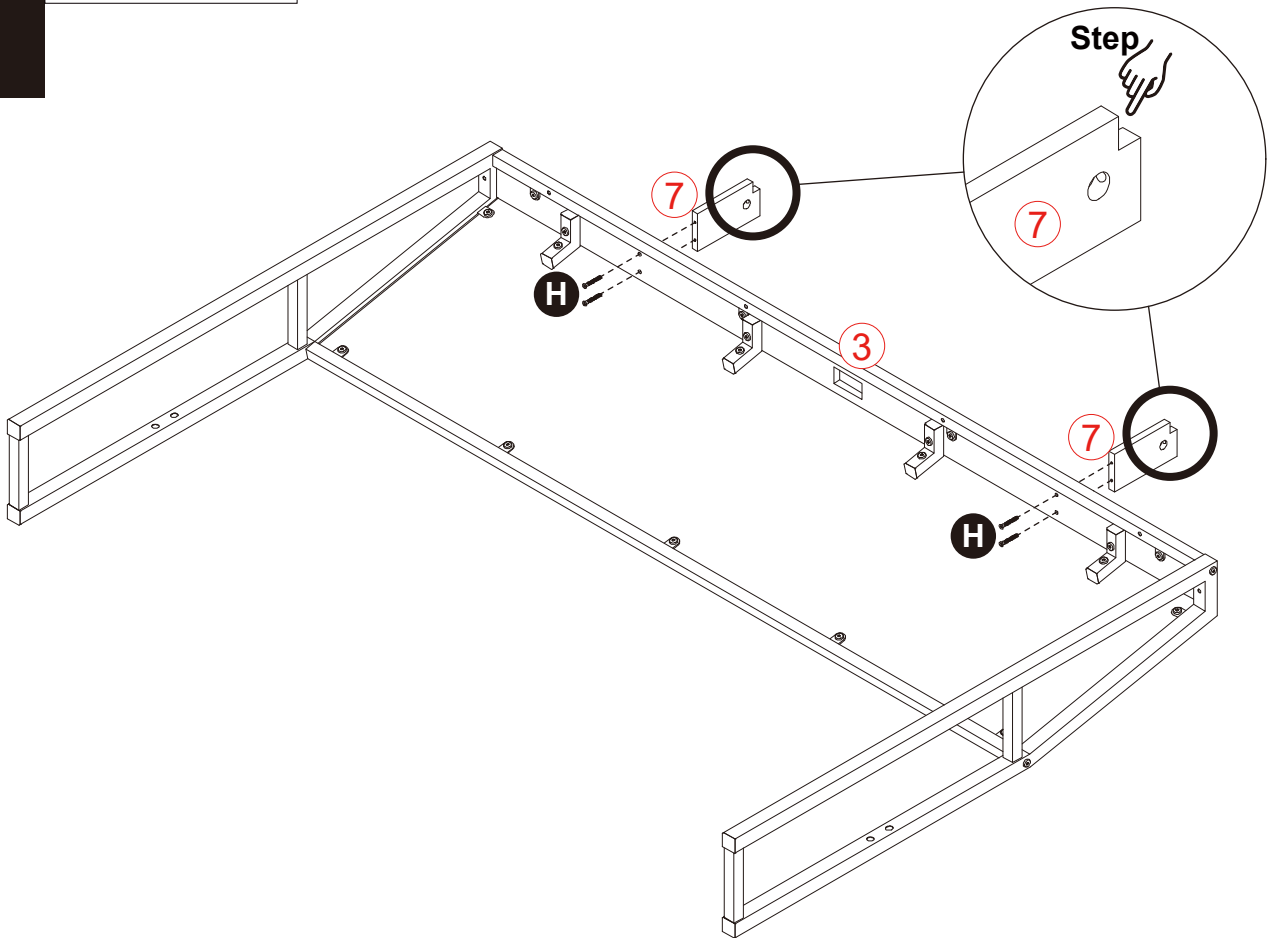

4

 H x 4

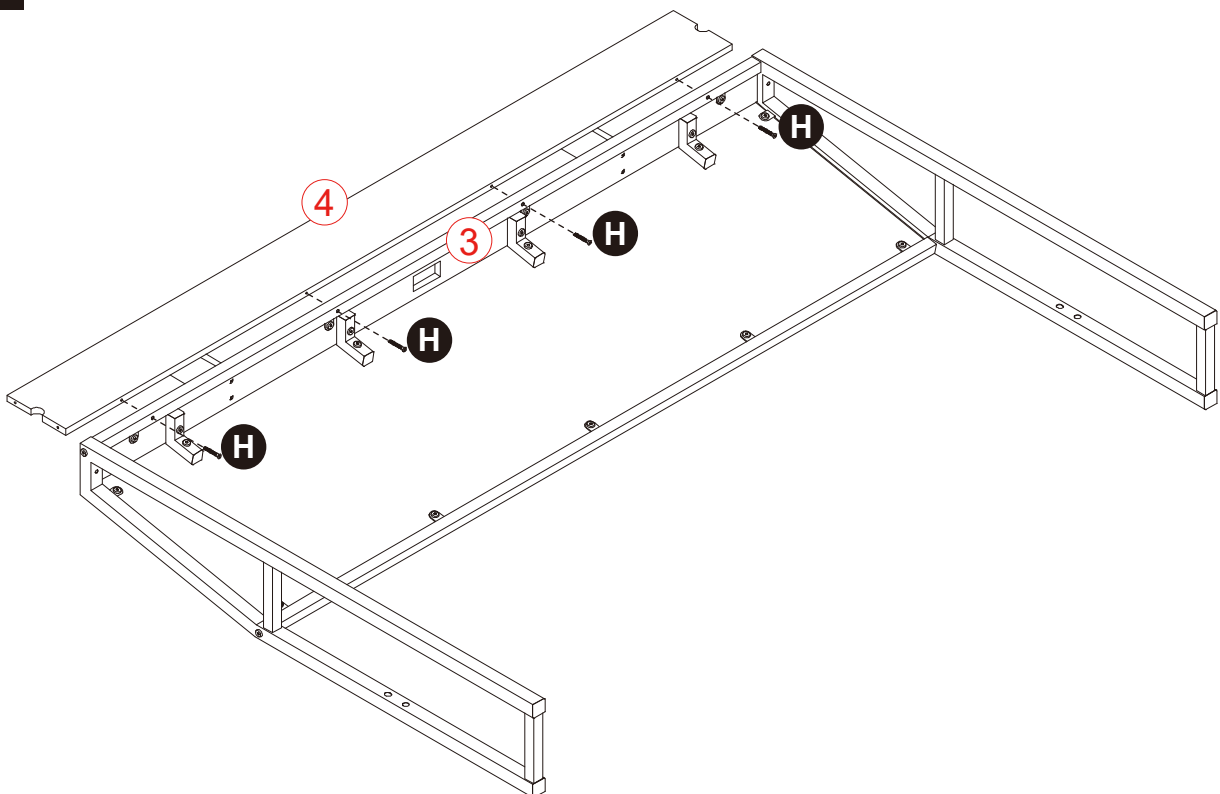

5

I x 2 H x 6

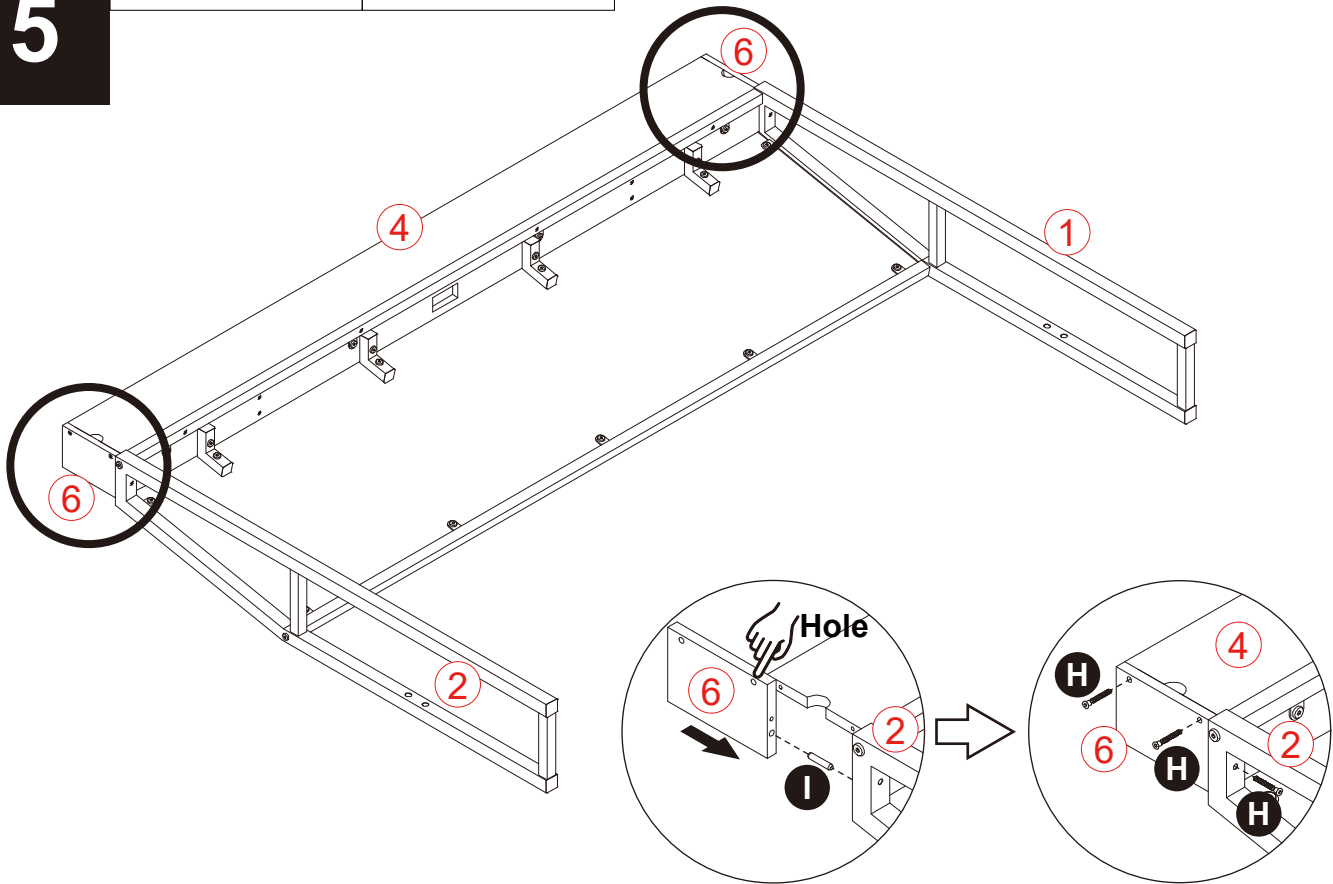

6

F x 2

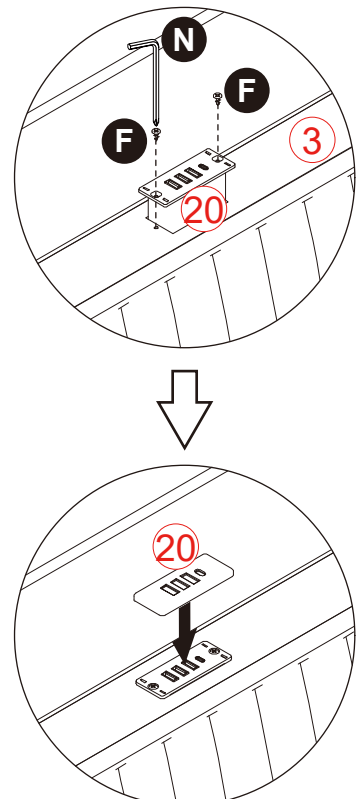
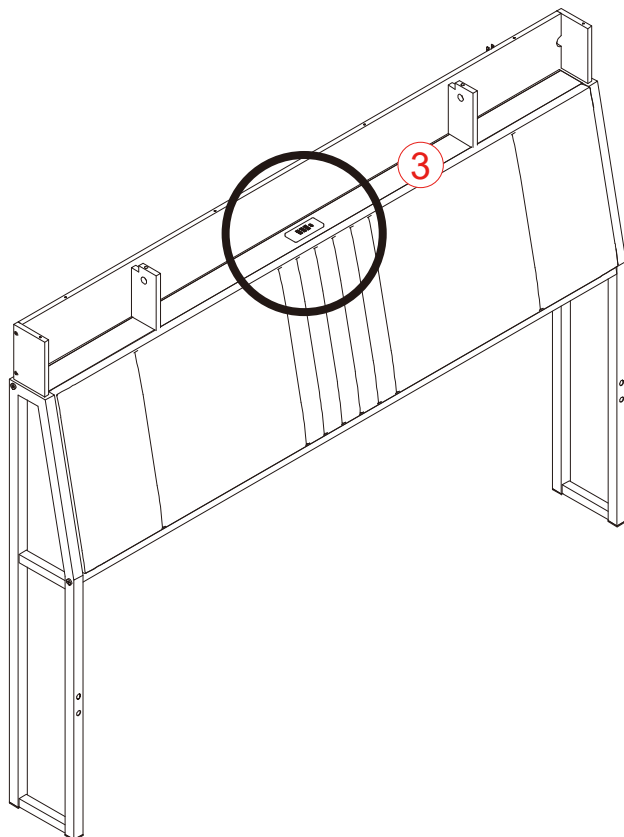

7

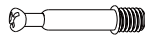
 J x 2

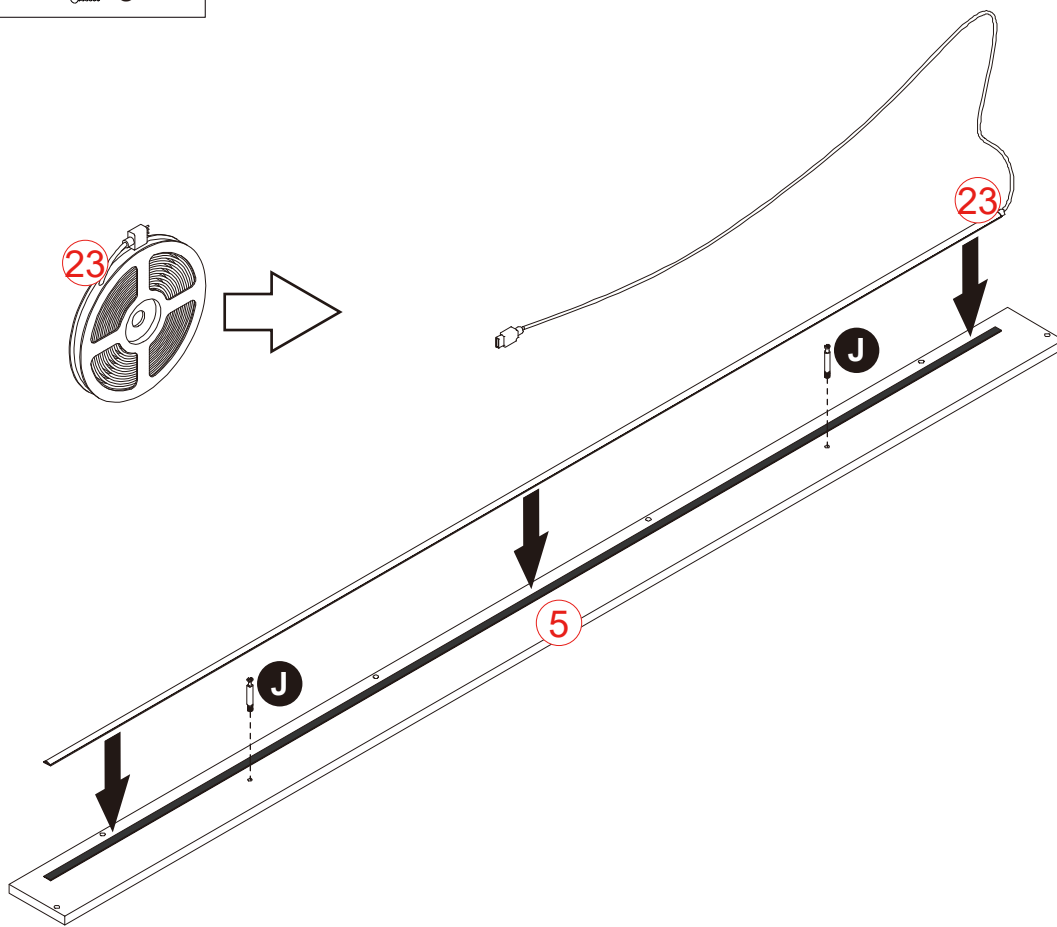

8

 K x 2  H x 6

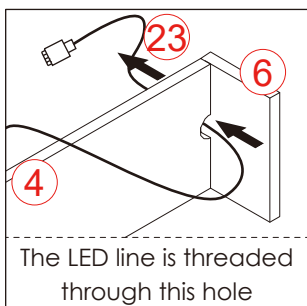
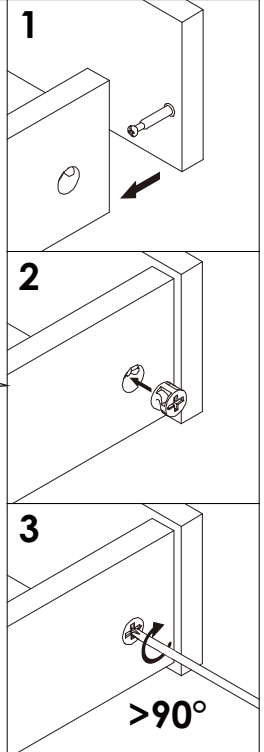
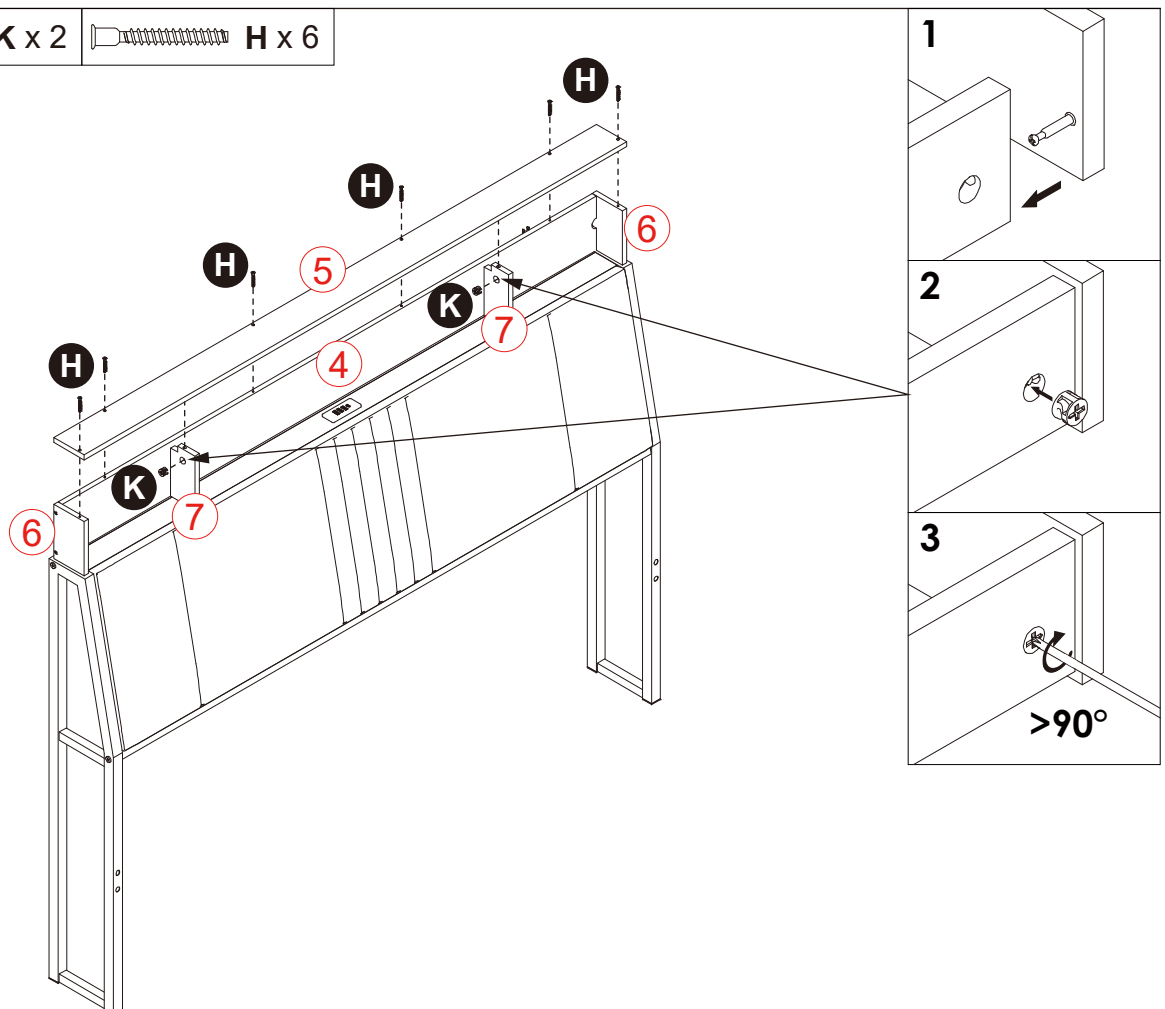

9

 C x 4

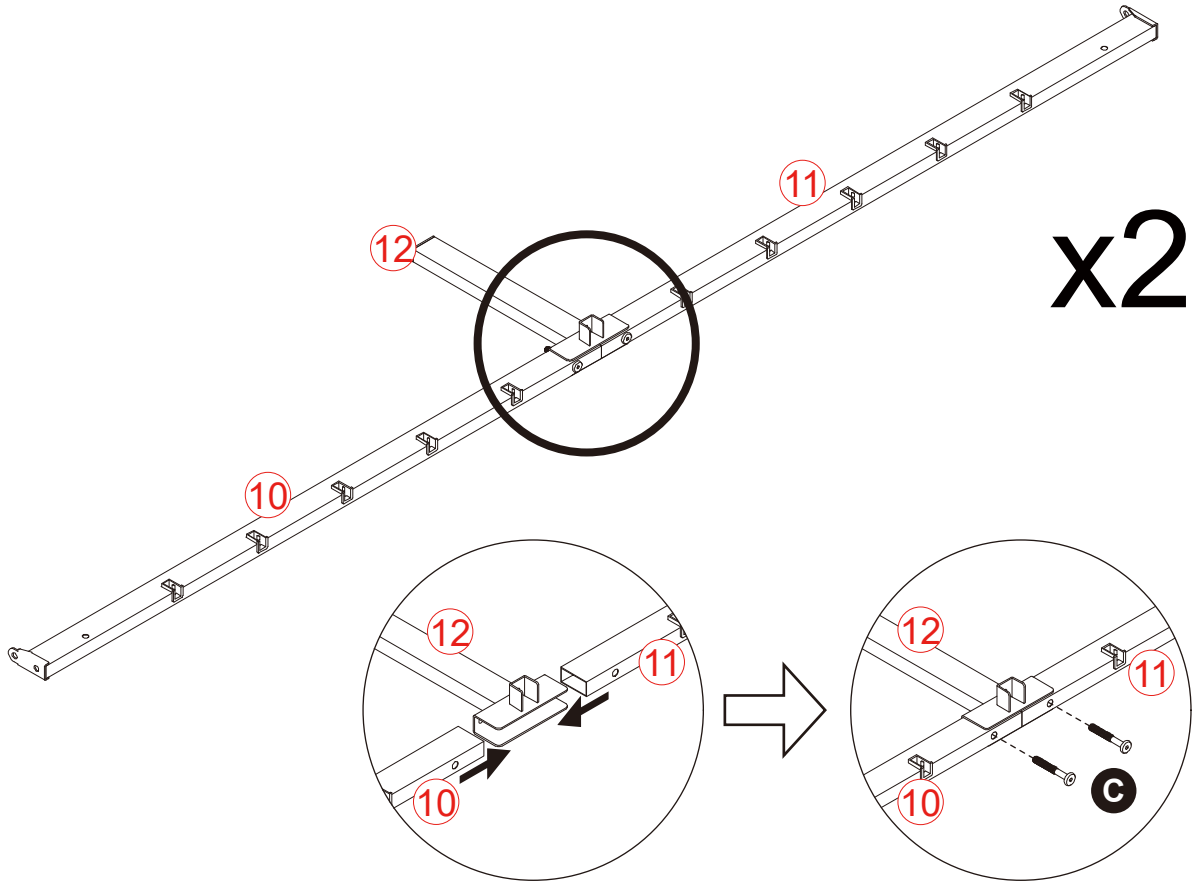

10

 E x 4  D x 8

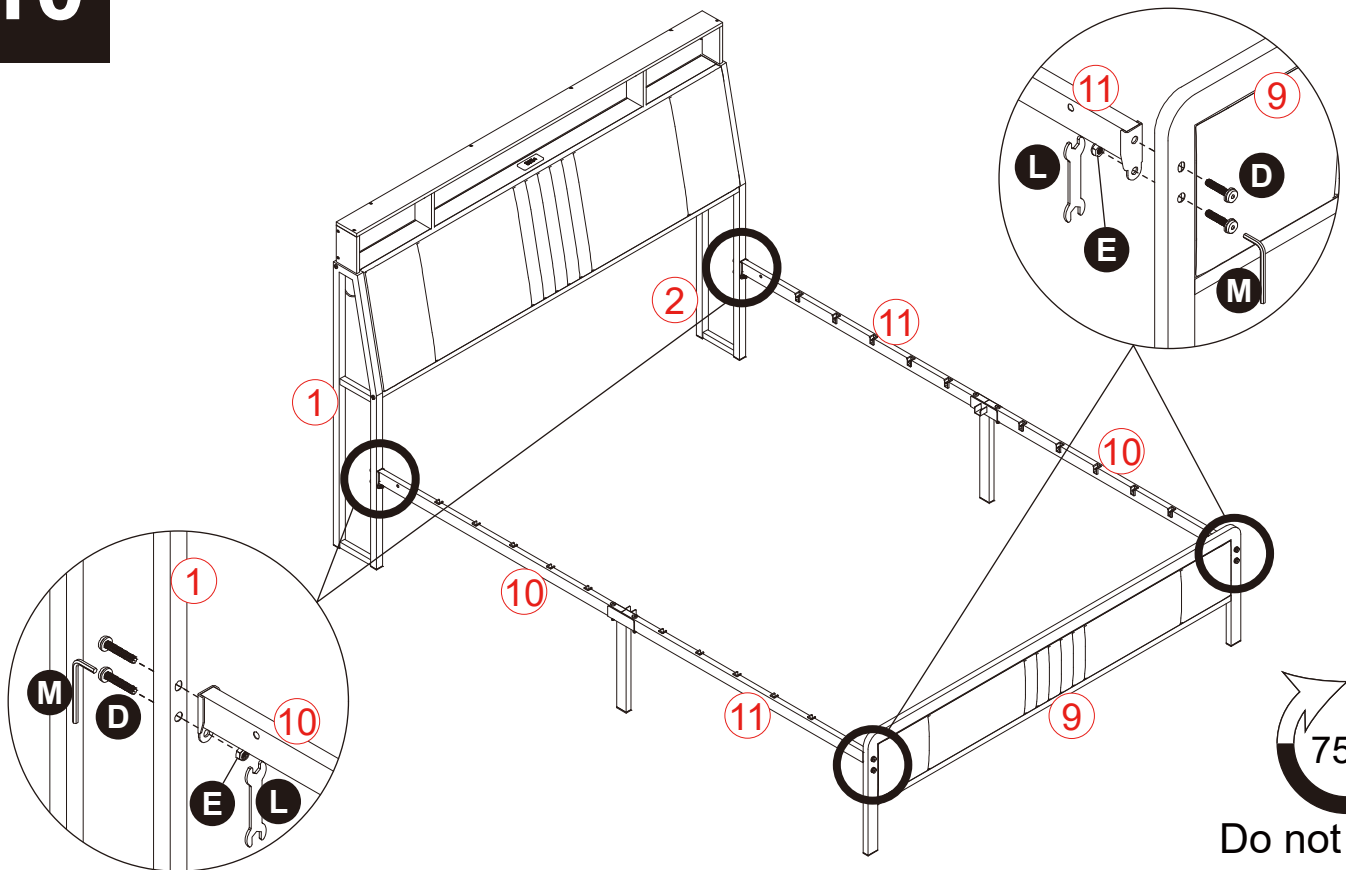



75%
Do not tighten too much

11

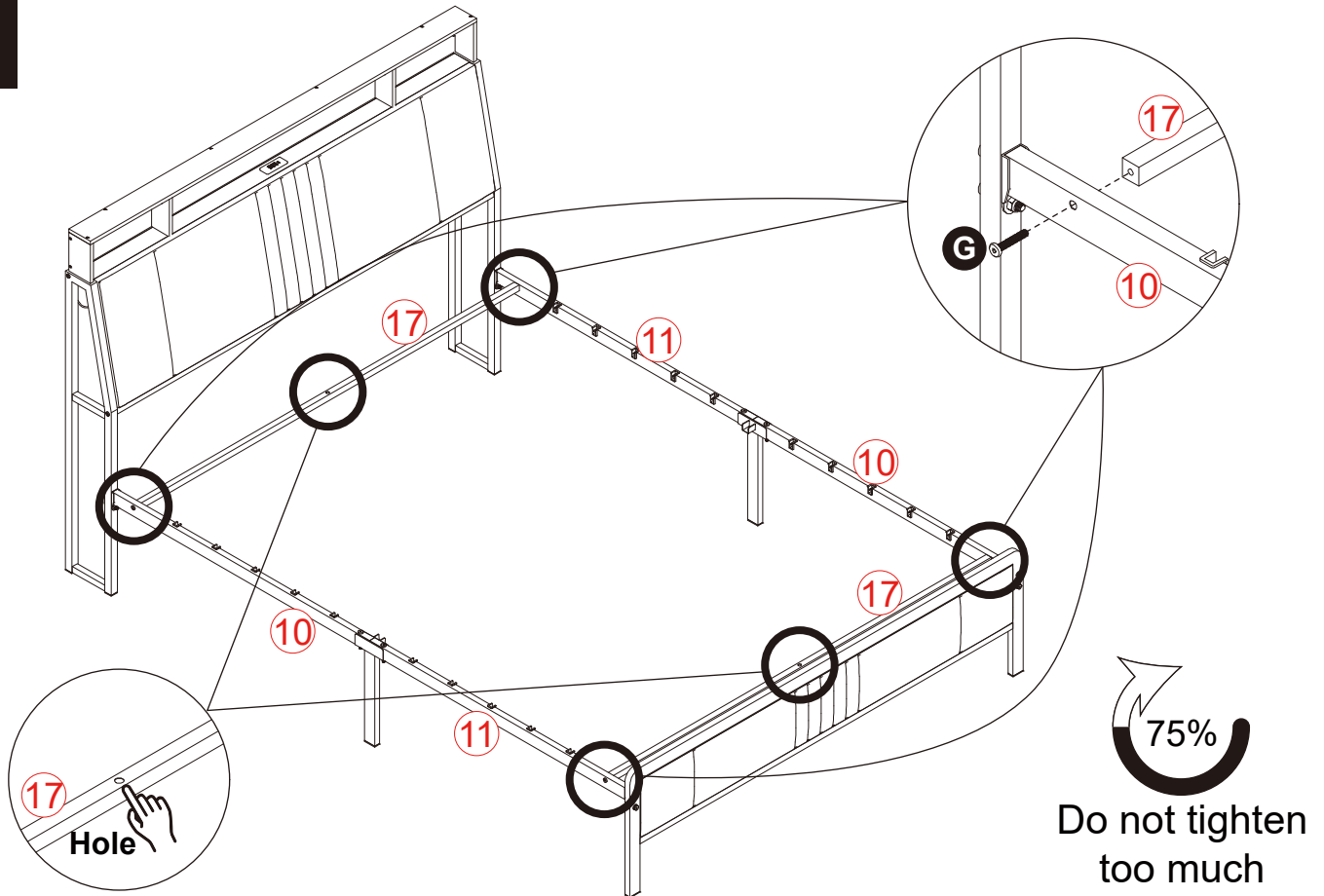
 G x 4



12

 C x 1  B x 2

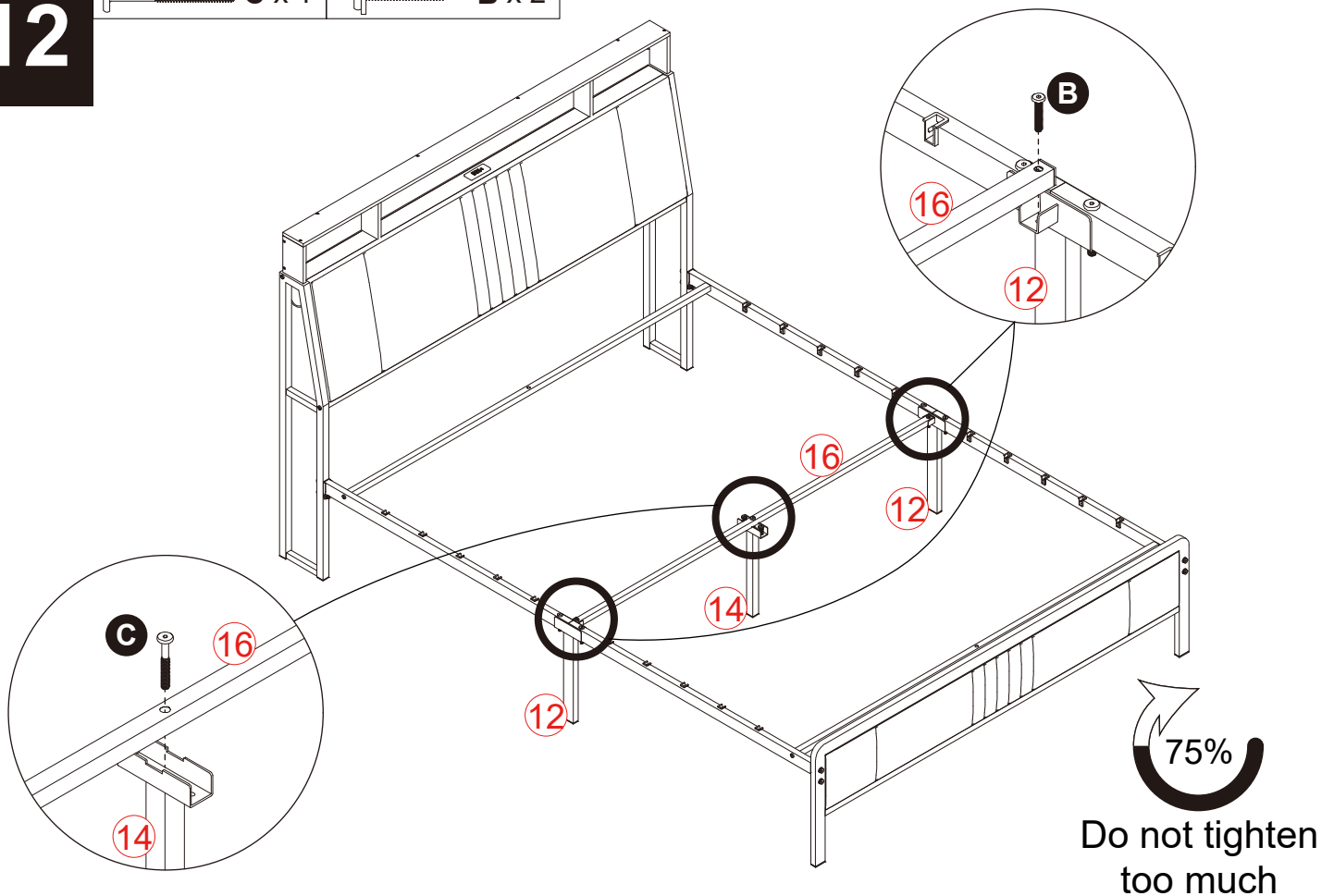

13

 C x 2

 D x 2



Tighten all the bolts
after assembling
this step

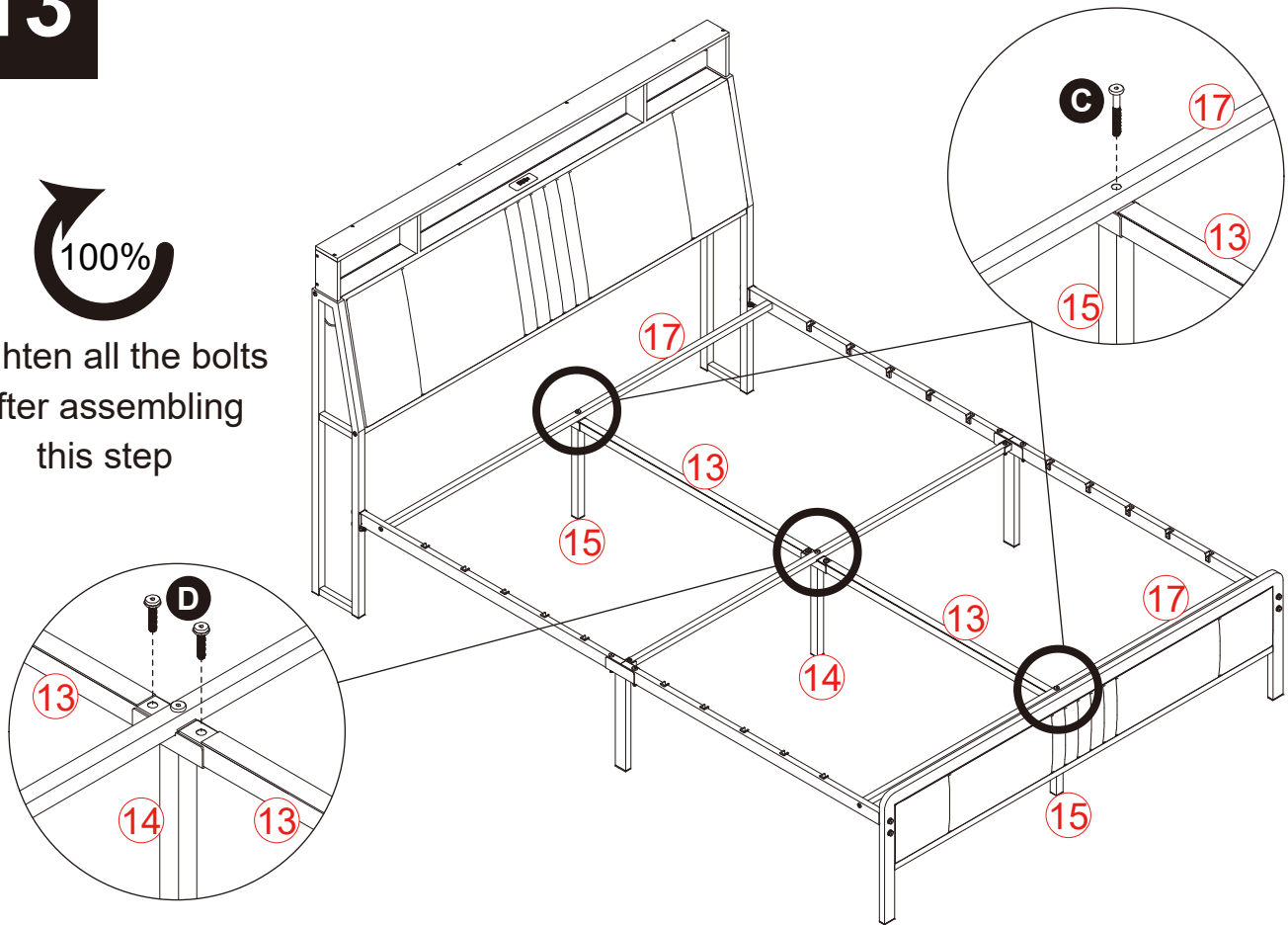

14

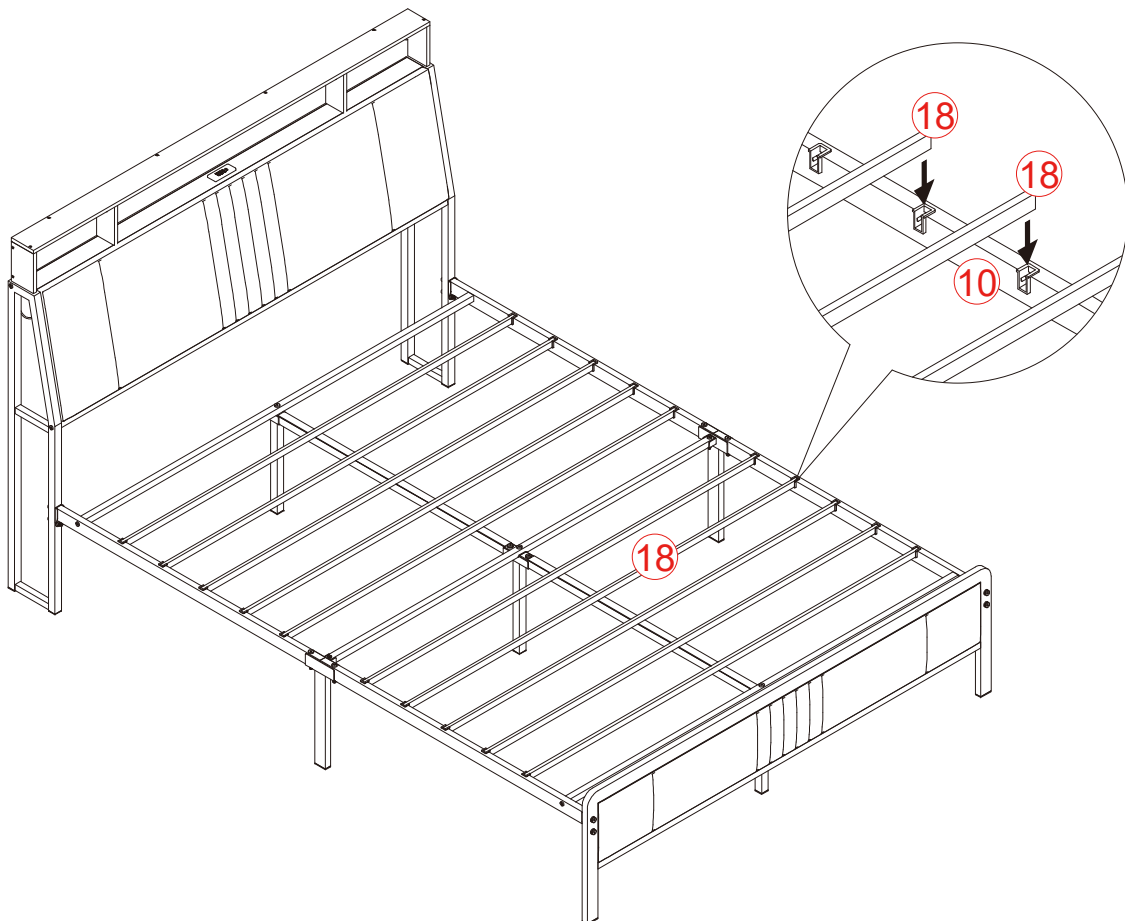

13

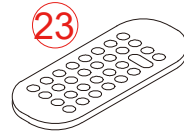

Remote Control

You can use the remote to control the light. The LED lamp can only be used after the power supply is connected.

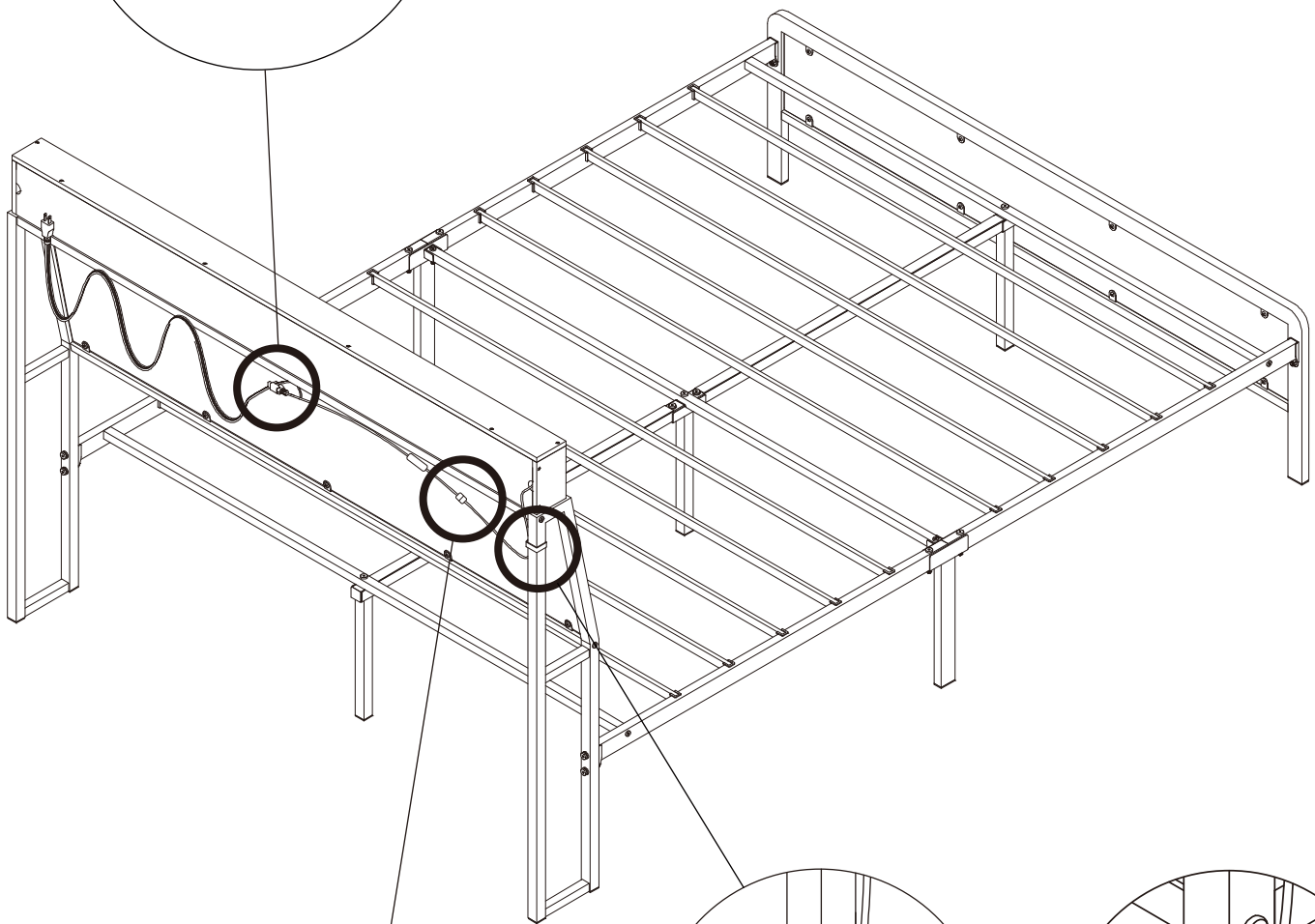
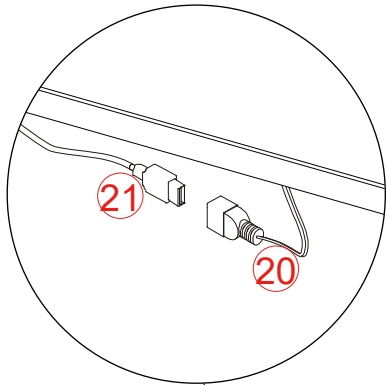

NOTE: The square part of the receiver (21) needs to be exposed to air in order to better control the LED light.

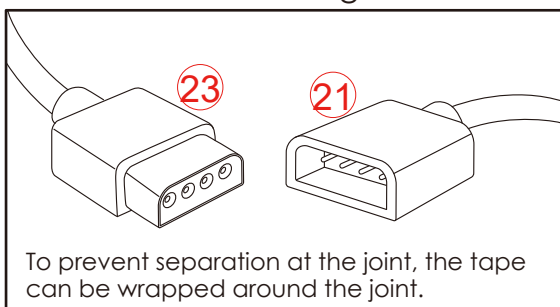

To prevent separation at the joint, the tape can be wrapped around the joint.

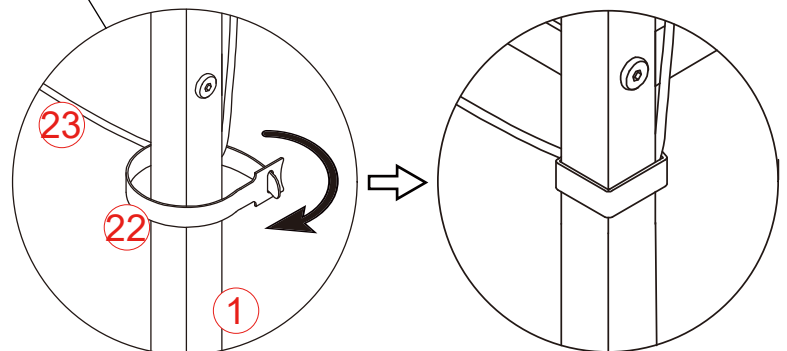

Secure the Led light strip with straps.

COMPLETE

Changes or modifications not expressly approved by the party responsible for compliance could void the user's authority to operate the equipment.

This equipment has been tested and found to comply with the limits for a Class B digital device, pursuant to Part 15 of the FCC Rules.

These limits are designed to provide reasonable protection against harmful interference in a residential installation.

This equipment generates uses and can radiate radio frequency energy and, if not installed and used in accordance with the instructions, may cause harmful interference to radio communications. However, there is no guarantee that interference will not occur in a particular installation. If this equipment does cause harmful interference to radio or television reception, which can be determined by turning the equipment off and on, the user is encouraged to try to correct the interference by one or more of the following measures:

- Reorient or relocate the receiving antenna.
- Increase the separation between the equipment and receiver.
- Connect the equipment into an outlet on a circuit different from that to which the receiver is connected.
- Consult the dealer or an experienced radio/TV technician for help.

This device complies with Part 15 of the FCC Rules. Operation is subject to the following two conditions:

- (1) This device may not cause harmful interference, and
- (2) This device must accept any interference received, including interference that may cause undesired operation.

This equipment complies with FCC radiation exposure limits set forth for an uncontrolled environment. This equipment should be installed and operated with minimum distance 20cm between the radiator & your body.