

SINGLE EGG CHAIR

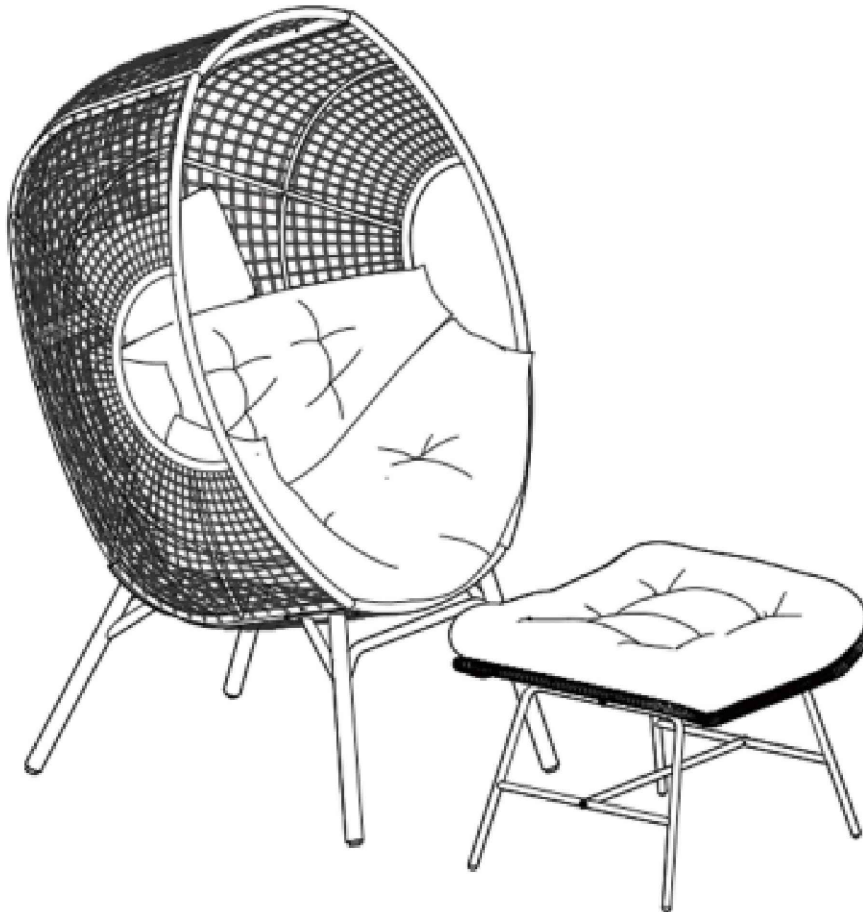

ATTENTION Section:

1. If you encounter any issues, such as missing accessories or damaged parts, please contact us immediately and include pictures.





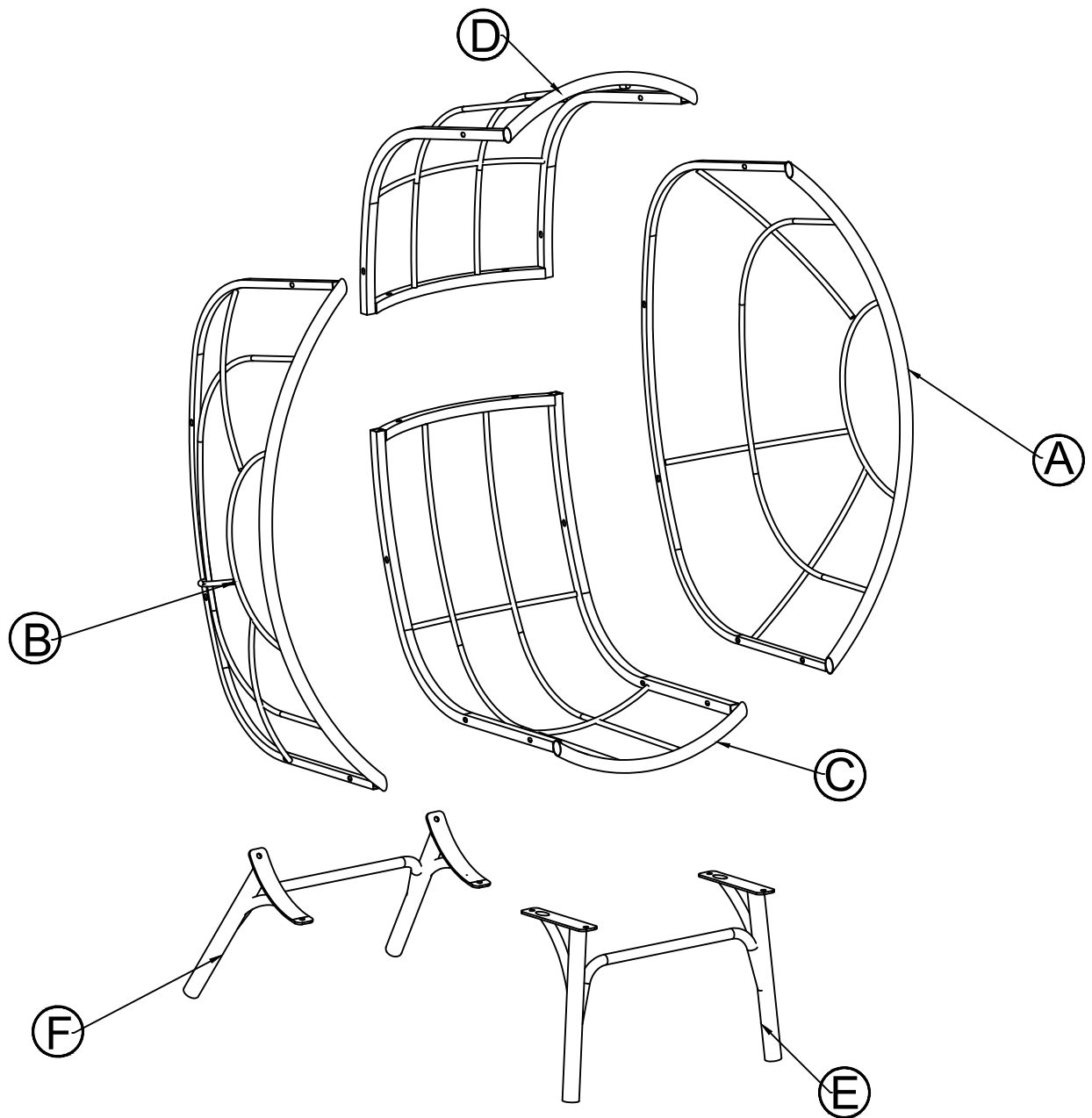

Assembly Instructions:

1. Assembly requires two people to complete.
2. For optimal assembly, we highly recommend using the provided Allen key.
If using a power tool, please set it to a low speed to prevent any damage
3. Do not fully tighten the screws until all screws are properly aligned with their holes.

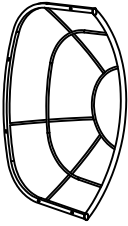
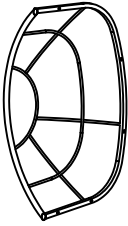
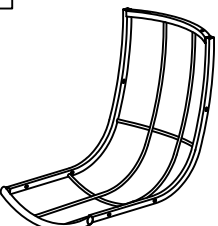
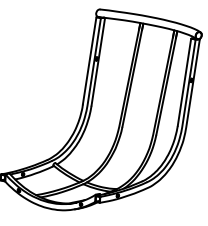
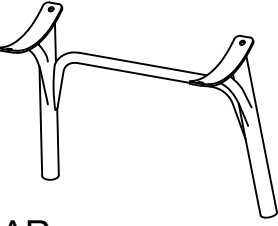
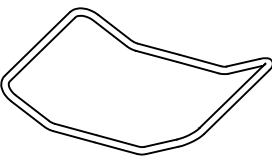
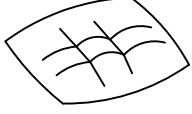
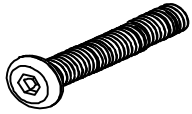
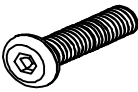
Exploded view



PARTS LIST OF BOX A

<p>A</p>  <p>LEFT PLATE 1pc</p>	<p>B</p>  <p>RIGHT PLATE 1pc</p>	<p>C</p>  <p>SEAT PLATE 1pc</p>	<p>D</p>  <p>TOP PLATE 1pc</p>
<p>E</p>  <p>FRONT CHAIR LEGS 1pc</p>	<p>F</p>  <p>REAR CHAIR LEGS 1pc</p>	<p>G</p>  <p>SEAT CUSHION 1pc</p>	<p>H</p>  <p>NECK PILLOW 1pc</p>
<p>M</p>  <p>PANEL OF FOOTSTOOL 1pc</p>	<p>J</p>  <p>LEGS OF FOOTSTOOL 2pcs</p>	<p>K</p>  <p>CROSSBAR 1pc</p>	<p>L</p>  <p>CUSHION OF FOOTSTOOL 1pc</p>
<p>①</p>  <p>M6*60 2pcs</p>	<p>②</p>  <p>M6*50 10pcs</p>	<p>③</p>  <p>M6*30 2pcs</p>	<p>④</p>  <p>M6*18 16pcs</p>
<p>⑤</p>  <p>M6 42pcs</p>	<p>⑥</p>  <p>M6 12pcs</p>	<p>⑦</p>  <p>M6 1pc</p>	<p>⑧</p>  <p>M6 1pc</p>

STEP 1

Do not fully tighten all screws until assembly is completed.

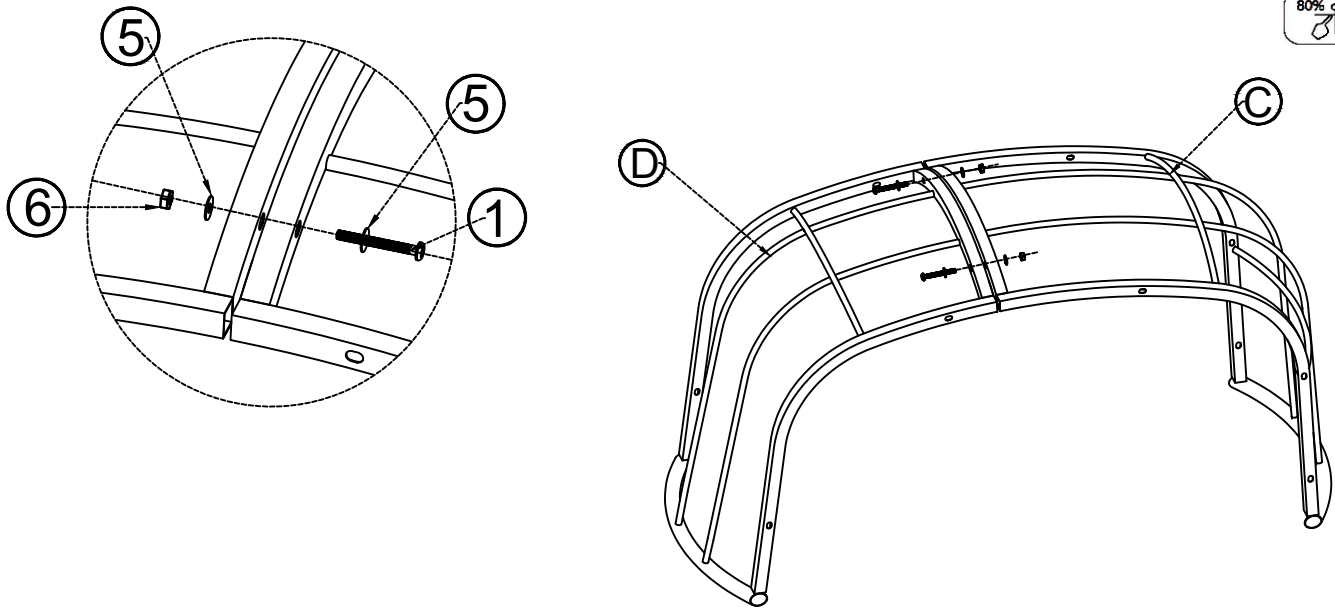
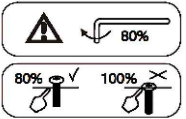

C	1pc	D	1pc	①	2pcs	⑤	4pcs	⑥	2pcs	⑦	1pc	⑧	1pc
				M6*60		M6		M6		ALLEN KEY M6		M6	

STEP 2

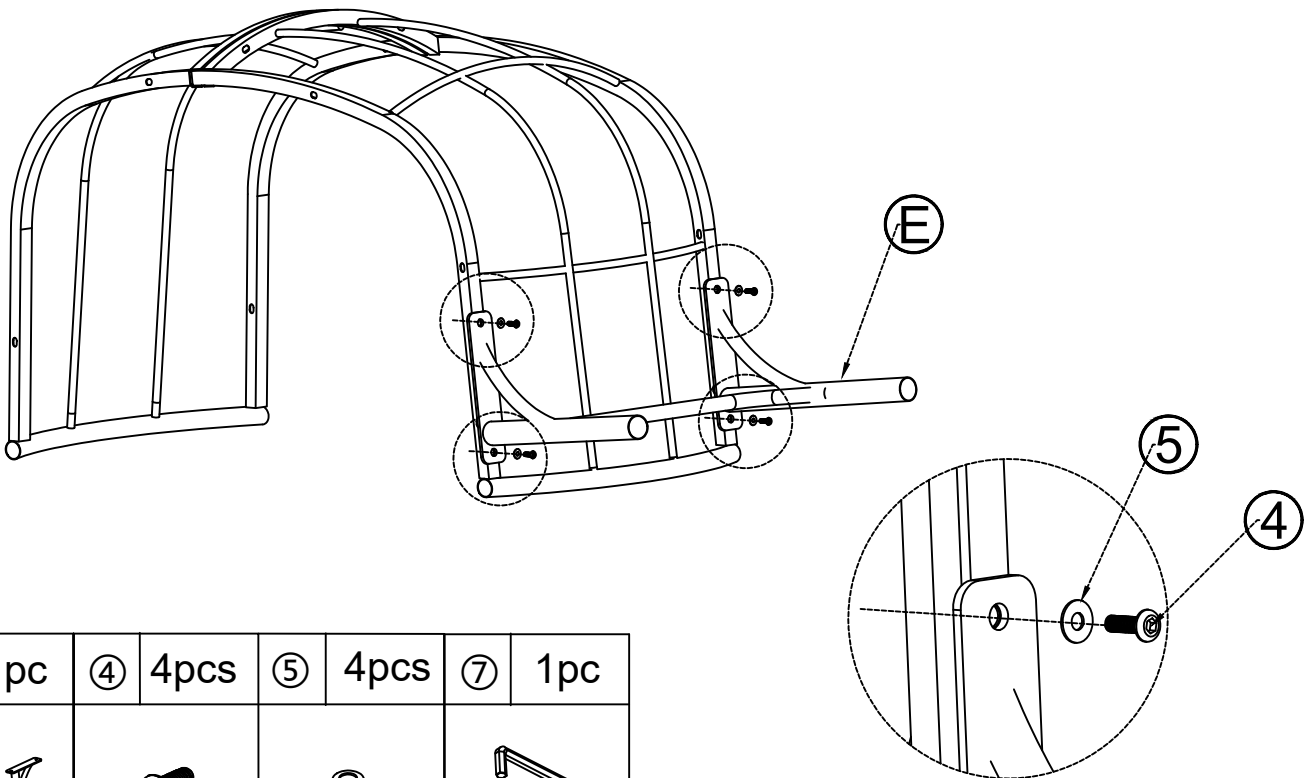
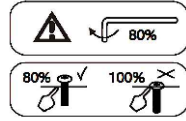

E	1pc	④	4pcs	⑤	4pcs	⑦	1pc
		M6*16		M6		ALLEN KEY M6	

STEP 3

Do not fully tighten all screws until assembly is completed.

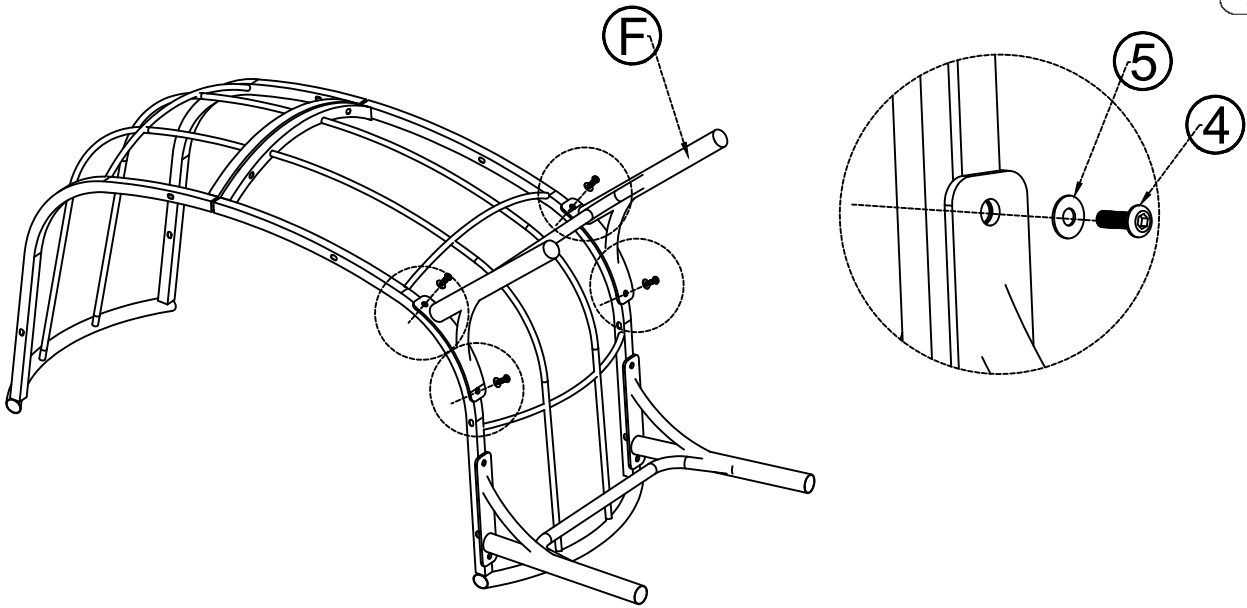
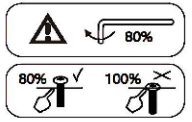

F	1pc	④	4pcs	⑤	4pcs	⑦	1pc
		M6*16		M6		ALLEN KEY M6	

STEP 4

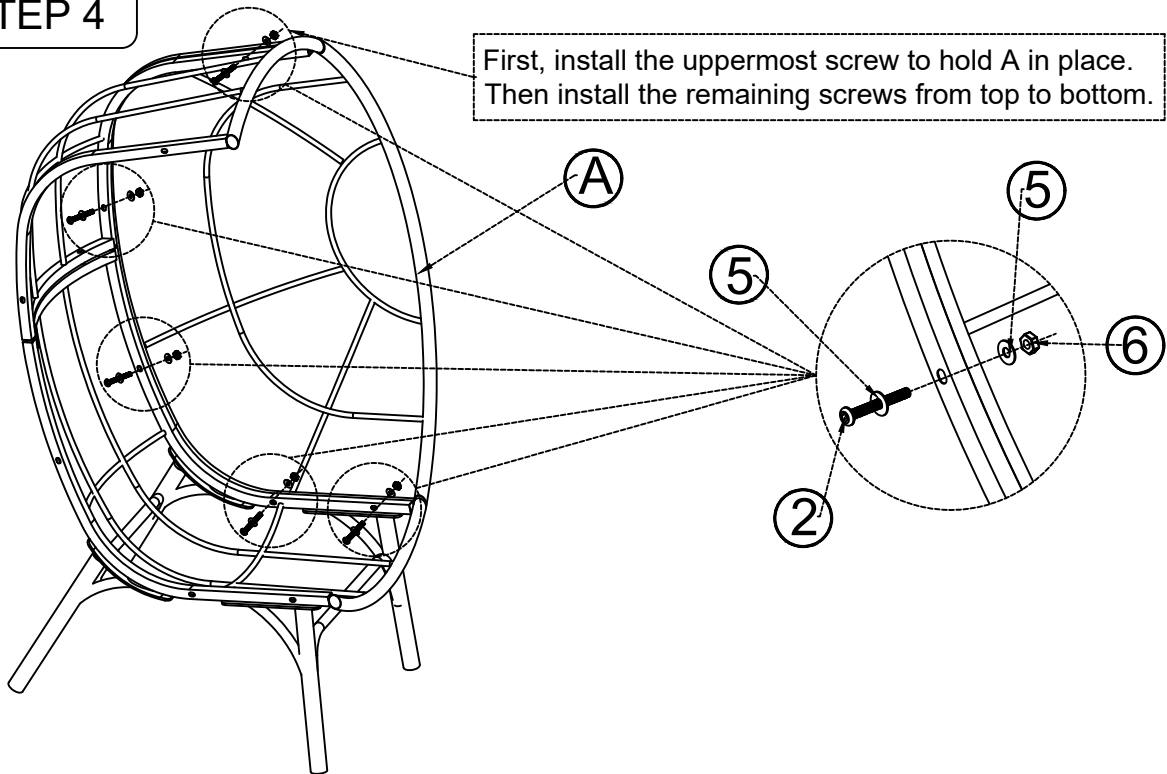
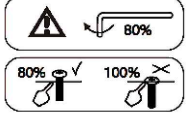

A	1pc	②	5pcs	⑤	10pcs	⑥	5pcs	⑦	1pc	⑧	1pc
		M6*50		M6		M6		ALLEN KEY M6		M6	

STEP 5

Do not fully tighten all screws until assembly is completed.

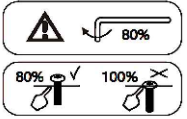

First, install the uppermost screw to hold B in place. Then install the remaining screws from top to bottom.

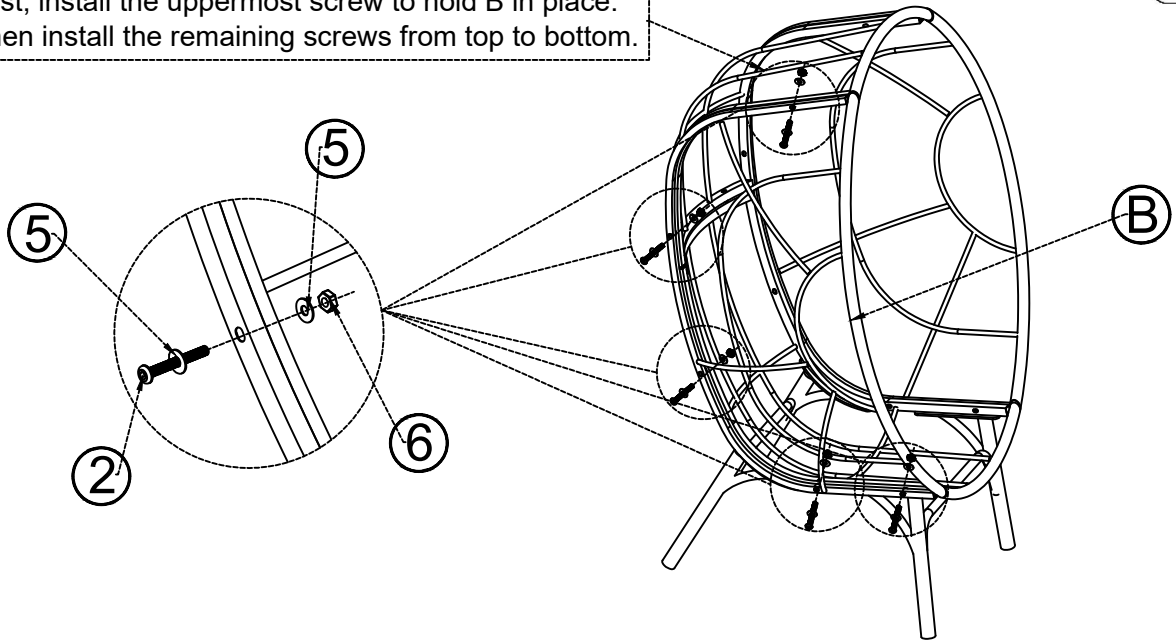

B	1pc	②	5pcs	⑤	10pcs	⑥	5pcs	⑦	1pc	⑧	1pc
		M6*50		M6		M6		ALLEN KEY M6		M6	

STEP 6

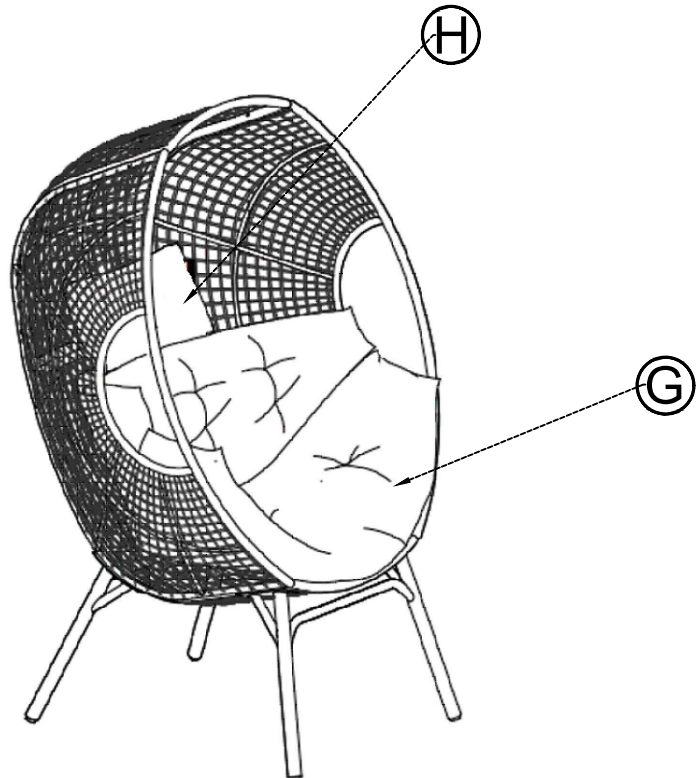
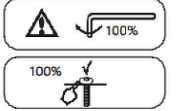

G	1pc	H	1pc

STEP 7

Do not fully tighten all screws until assembly is completed.

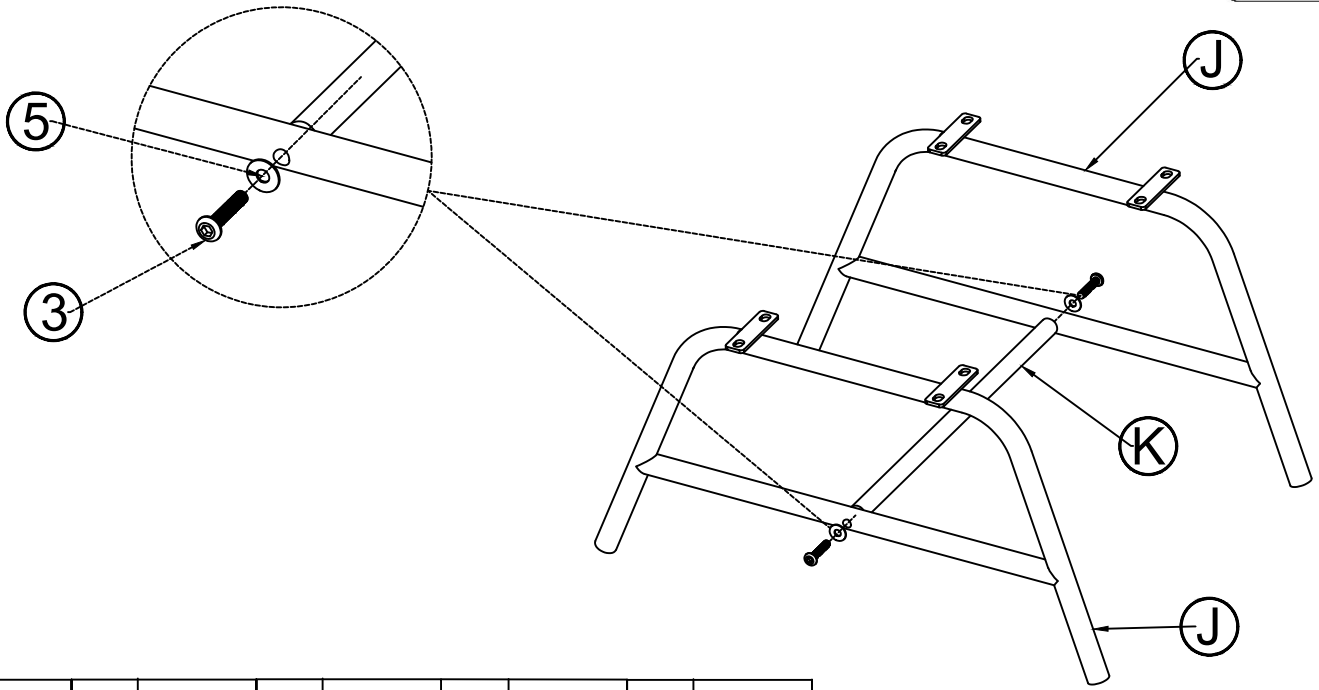
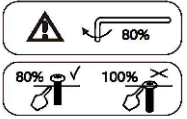

J	2pcs	K	1pc	③	2pcs	⑤	2pcs	⑦	1pc
				M6*30		M6		ALLEN KEY M6	

STEP 8

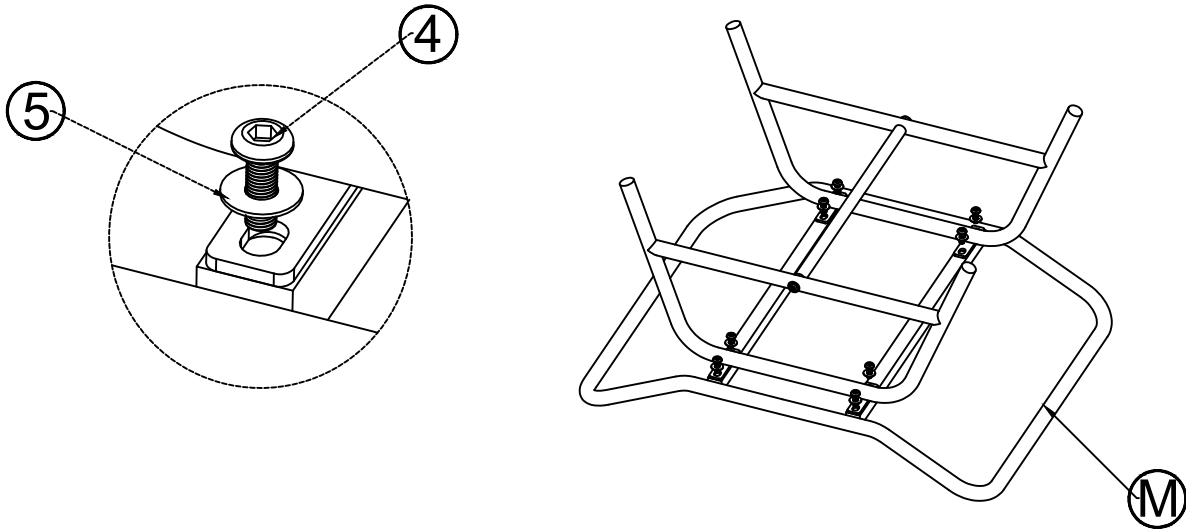
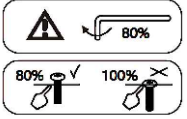

M	1pc	④	8pcs	⑤	8pcs	⑦	1pc
		M6*16		M6		ALLEN KEY M6	

STEP 9

Do not fully tighten all screws until assembly is completed.

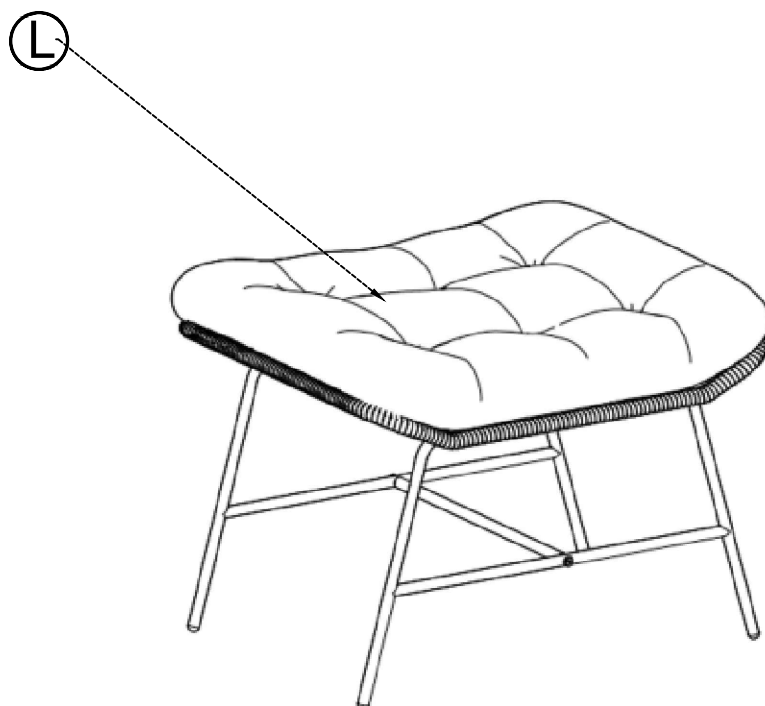
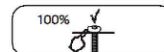

L | 1pc

