

IMPORTANT SAFETY NOTICE: READ CAREFULLY BEFORE BEGINNING ASSEMBLY!

- * Always use proper tools.
- * Follow the assembly steps in order. Do not skip any steps.
- * Be sure to check all packing materials carefully for small parts may have come loose inside the carton during shipment. If parts are missing, contact the retailer from which you purchased the product to obtain any missing parts. **DO NOT USE SUBSTITUTE PARTS.**
- * Periodically check to ensure that all connectors (bolts, screws, etc.) are tight.
- * Keep the instructions for future reference.
- * Some assembly may involve attaching glass or mirrors. Be very careful handling the glass or mirrors, as severe injury may result if the glass or mirror breaks. Never handle large pieces of glass or mirrors by yourself.
- * When assembling products that have electric cords (lamps, light, etc.), always (1) make sure the electrical cord is unplugged before assembly and (2) be careful not to twist the electrical cord during assembly.
- * When assembling shelves or entertainment centers, do not stand on lower shelves in order to assemble upper shelves—use a step ladder.
- * Do not stand on tables, including but not limited to, end tables, coffee tables, and dinner tables, as tables are not to support the weight of a person.
- * Where assembly instructions state that the assembly requires two or more people, **do not** attempt by yourself as there is a risk of injury.

NOTE: YOUR UNIT MAY LOOK DIFFERENT IN APPEARANCE FROM THE ONE SHOWN IN THE ILLUSTRATIONS ON THIS INSTRUCTION SHEET.

NOTICIA IMPORTANTE DE SEGURIDAD: LEA CUIDADOSAMENTE ANTES DE COMENZAR A ENSAMBLAR

- * Siempre use las herramientas apropiadas.
- * Siga los pasos de ensamble en orden. No salte ningún paso.
- * Asegúrese de comprobar con cuidado todos los materiales de embalaje en busca de piezas pequeñas que hayan podido desprenderse dentro del cartón durante el envío. Revise la lista de partes. Si faltan partes, comuníquese con el surtidor del cual usted compró el producto para obtener las partes que le faltan. **NO USE PARTES SUSTITUTAS.**
- * Periódicamente revise para asegurarse que todos los conectores (pernos, tornillos, etc.) estén bien apretados.
- * Guarde las instrucciones para referencia futura.
- * Algunos de los ensambles involucran vidrios o espejos. Tenga cuidado al manejar estos vidrios o espejos, ya que puede lesionarse severamente si uno de estos vidrios o espejos se rompe. Nunca maneje piezas grandes de vidrio o espejo sin ayuda.
- * Al armar productos con cables eléctricos (lamps, lights, etc.), siempre (1) asegúrese que el cable esté desenchufado antes de armar (2) tenga cuidado de no doblar el cable al marmar..
- * Al armar repisas o centros de entretenimiento, no se pare en las repisas de abajo para armar las repisas de arriba—use una escalera.
- * No se pare en las mesas, incluyendo pero sin límite a, mesas laterales, mesas de centro, mesas de comedor, ya que estas mesas no están diseñadas para soportar el peso de una persona.
- * Si las instrucciones dicen que se debe usar dos o más personas **no** trate de armarlo solo, ya que corre el riesgo de lastimarse.

NOTA: LA UNIDAD PUEDE PRESENTAR UNA APARIENCIA DIFERENTE DE LA QUE SE MUESTRA EN LAS ILUSTRACIONES DE LA HOJA DE INSTRUCCIONES.

REMARQUE IMPORTANTE CONCERNANT LA SECURITÉ: LIRE ATTENTIVEMENT AVANT DE COMMENCER LE MONTAGE!











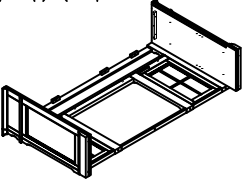
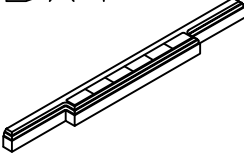
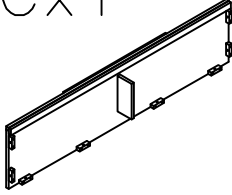

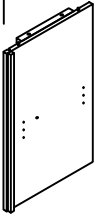
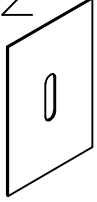
- * Utilisez toujours les outils adaptés.
- * Suivez l'ordre des étapes de montage. N'en sautez aucune.
- * Assurez-vous de vérifier attentivement tous les matériaux d'emballage parce que les petites pièces peuvent se détacher à l'intérieur de la boîte lors de l'expédition. Faites l'inventaire attentif de toutes les pièces. Si une ou plusieurs pièces manquent, contactez votre revendeur pour obtenir les pièces en question. **N'UTILISEZ PAS DE PIÈCES DE SUBSTITUTION.**
- * Vérifiez de temps à autre que tous les connecteurs (boulons, vis, etc.) sont bien serrés.
- * Gardez ces instructions pour pouvoir les consulter ultérieurement.
- * Certaines étapes du montage peuvent nécessiter l'installation de verres ou de miroirs. Soyez extrêmement prudent lors de la manipulation des verres ou des miroirs, car vous pourriez vous blesser gravement si le verre venait à casser. Ne manipulez jamais seul de grands objets en verre ou de grands miroirs.
- * Lors de l'assemblage des produits qui comportent des fils électriques (lampes, lumières, etc.), assurez-vous toujours (1) que le câble électrique est débranché avant de procéder au montage et (2) faites attention à ne pas secouer le câble électrique pendant le montage.
- * Lors du montage des étagères ou un meuble audio-vidéo, ne vous tenez pas sur les étagères inférieures pour installer les étagères supérieures. Utilisez un escabeau.
- * Ne vous tenez pas sur les tables, ce qui comprend mais pas uniquement, les tables d'extrémité, les tables basses, les tables à dîner, car elles ne sont pas destinées à supporter le poids des personnes.
- * Lorsque les instructions de montage mentionnent que l'installation nécessite deux personnes ou plus, n'essayez pas de monter vous-même le produit, car vous risqueriez de vous blesser.

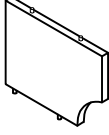
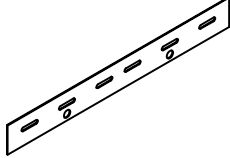
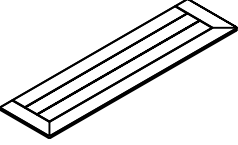
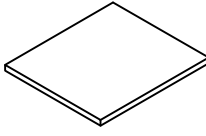
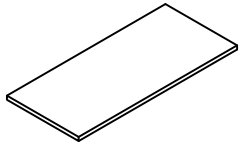
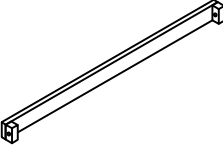
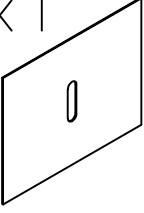
REMARQUE: VOTRE MEUBLE PEUT ETRE DIFFERENT DE CELUI MONTRE SUR L'ILLUSTRATION DE CETTE FEUILLE D'INSTRUCTIONS.

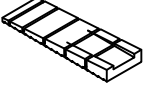
重要安全提示：组装家具前请仔细阅读以下指南！

- * 请使用合适的工具进行组装。
- * 按照组装步骤逐步完成，请勿跳过任一步骤。
- * 由于小的零部件有可能在运输过程中散落于包装箱内，请仔细检查包装材料。如若发现部件丢失，请及时联系当地零售商以获取丢失部件。请勿用其它零部件替代。
- * 定期检查以确保所有连接处（螺丝，螺杆等）均已拧紧。
- * 请妥善保存该安装说明，以备将来需要时参考。
- * 当产品中用到玻璃和镜子，安装时请小心操作，以防玻璃或镜子破碎造成伤害。请勿独自安装大块玻璃或者镜子。
- * 对于附有电线的产品（台灯，立灯等），安装时请确保以下两点：
 1. 安装之前确保电源断开。
 2. 安装过程中请勿扭曲电线。
- * 安装隔板或者电视柜时，请勿站在低层隔板上安装上层隔板，使用梯子进行安装。
- * 请勿站立在茶几，边几或者餐桌之类的桌子上，这些桌子不能够支撑人体重量。
- * 组装说明中一旦提及某一安装需要两到多人完成，请不要尝试独自安装，这样可能会对您人身安全构成威胁。

注意：您所购买的产品与该组装说明书中配图在外观上可能会有差异。

Ax1 	Bx1 	Cx1 	Dx1 
Ex1 	Fx2 	Gx1 	Hx1 
Jx1 	Kx1 	Lx2 	Mx1 
Nx1 	Px1 	R x 34  1/4" X 35mm	S x 5  1/4" X 51mm
T x 2 	U x 1  M4	W x 12 	Y x 2 
Z x 1 	 Not LLCluded No Se Adjunta Non LLClus 不提供此工具		

- ⚠ NOTE: UNIT SHOULD BE ASSEMBLED BY TWO OR MORE PEOPLE.
DO NOT TIGHTEN ANY BOLTS UNTIL ALL BOLTS HAVE BEEN STARTED!
- ⚠ NOTA: ¡ESTA UNIDAD DEBE SER ARMADA POR 2 O MAS PERSONAS!
NO APRIETE NINGUN PERNO HASTA QUE TODOS ESTEN EN SU LUGAR!
- ⚠ REMARQUE: LE MEUBLE DOIT ETRE ASSEMBLÉ PAR DEUX PERSONNES OU PLUS.
NE BLOQUER AUCUNE VIS TANT QUE VOUS N'AVEZ PAS COMMENCE A TOUTES LES DEMARRER!
- ⚠ 注意：产品应由两个或者两个以上的人员组装。
在产品组装过程中，不要锁紧螺栓！

NOTE: HARDWARE ARE STORED BACKSIDE OF FRONT FRAME

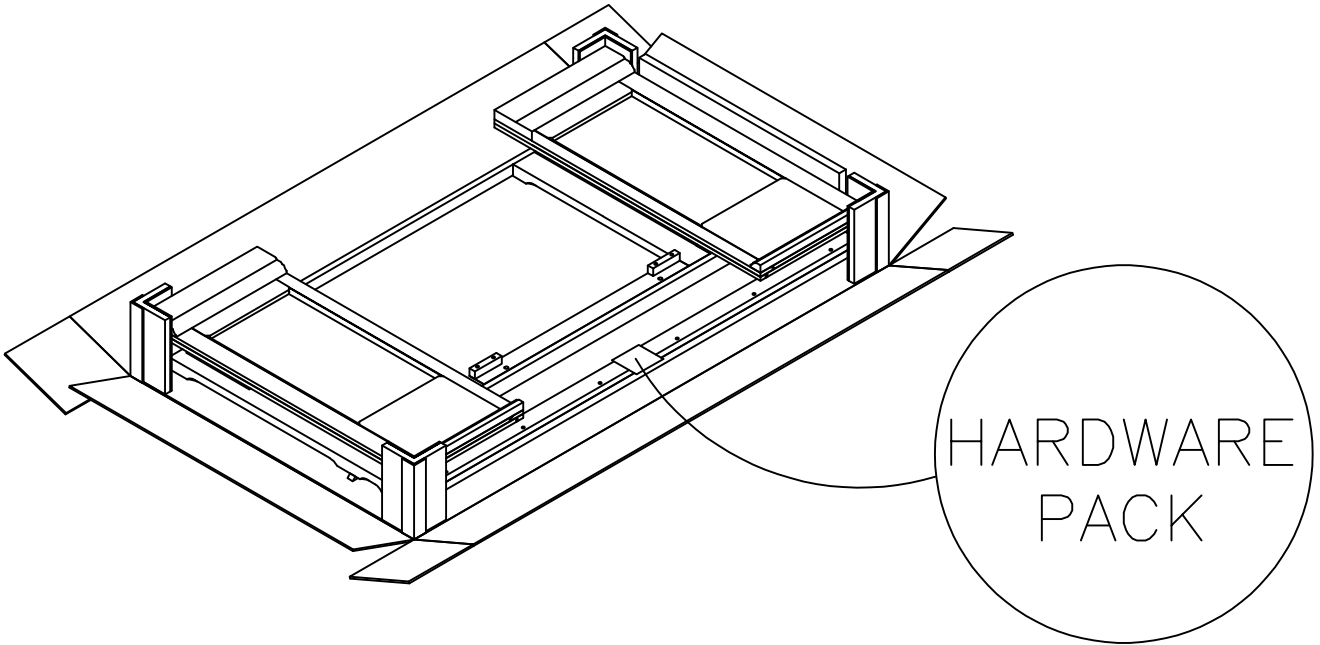

NOTE: ASSEMBLY INSTRUCTION FOR MULTIPLE UNITS, THE PARTS/LABEL INDEX ARE SEPARATED FOR DIFFERENT UNITS
THE PARTS ARE LOCATED INSIDE THE BOX AS BELOW

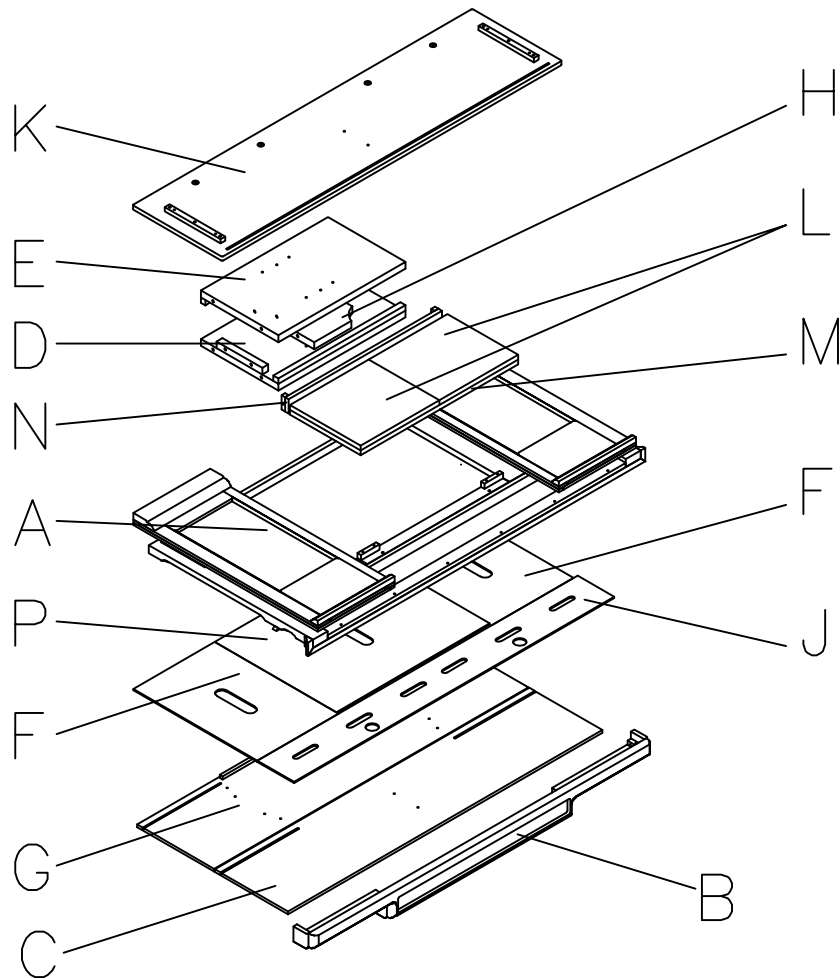

1

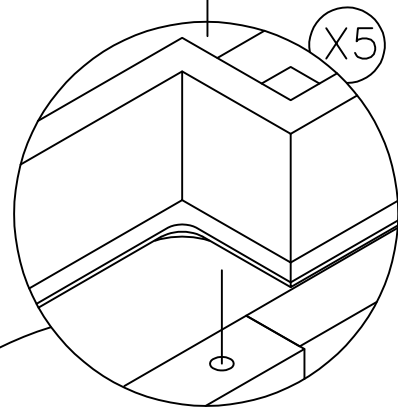
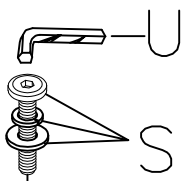
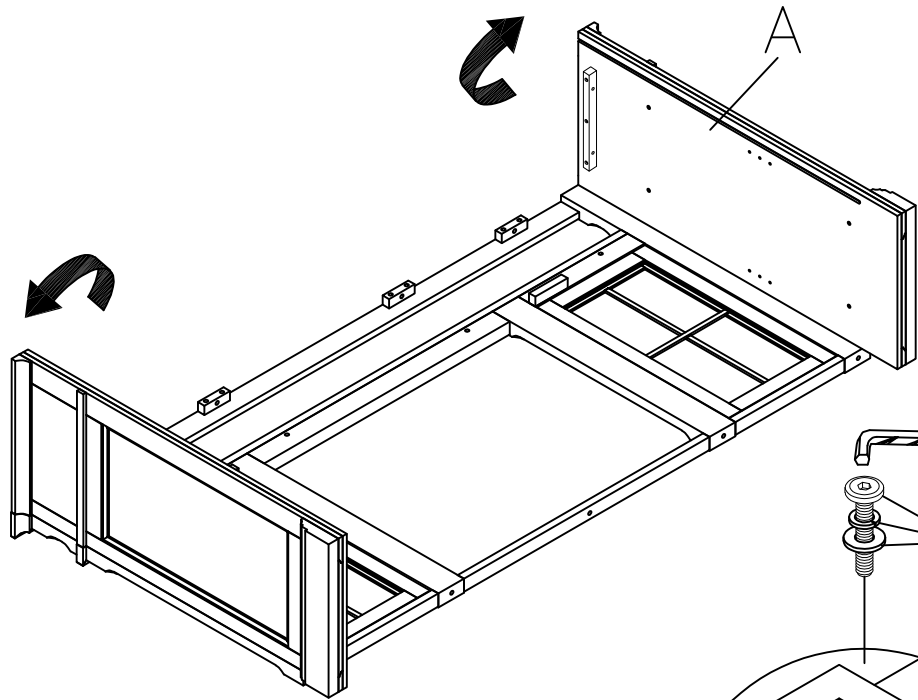

2

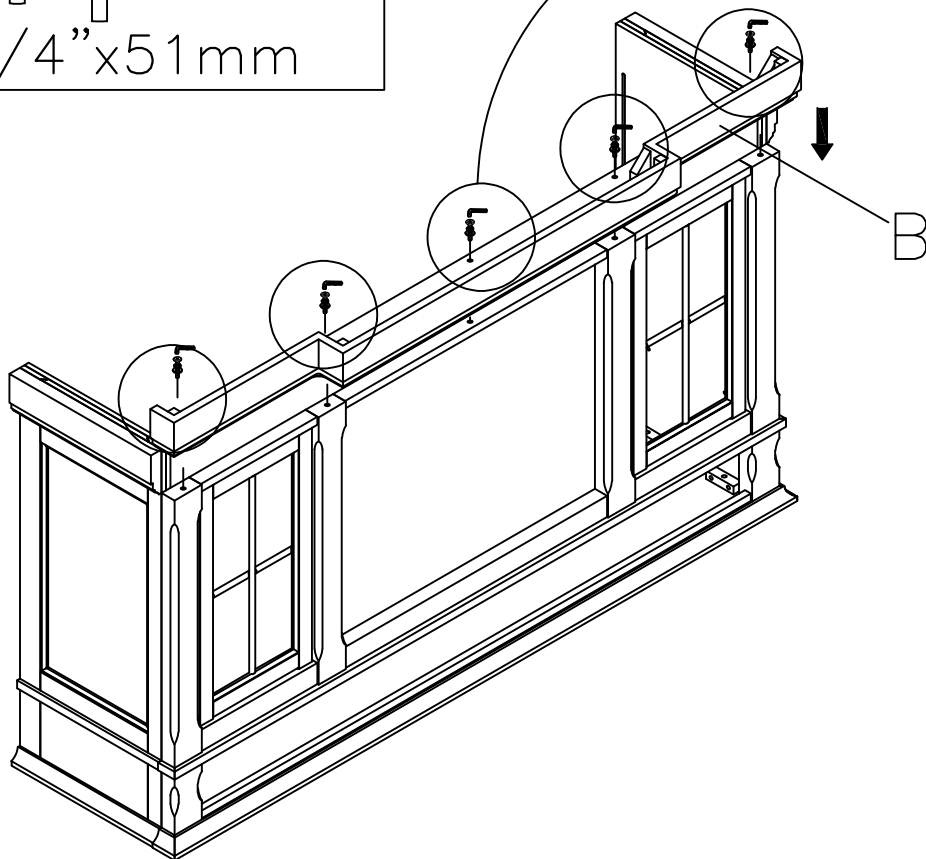
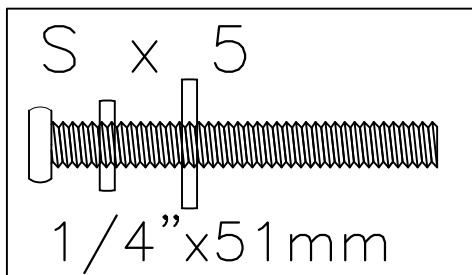

3

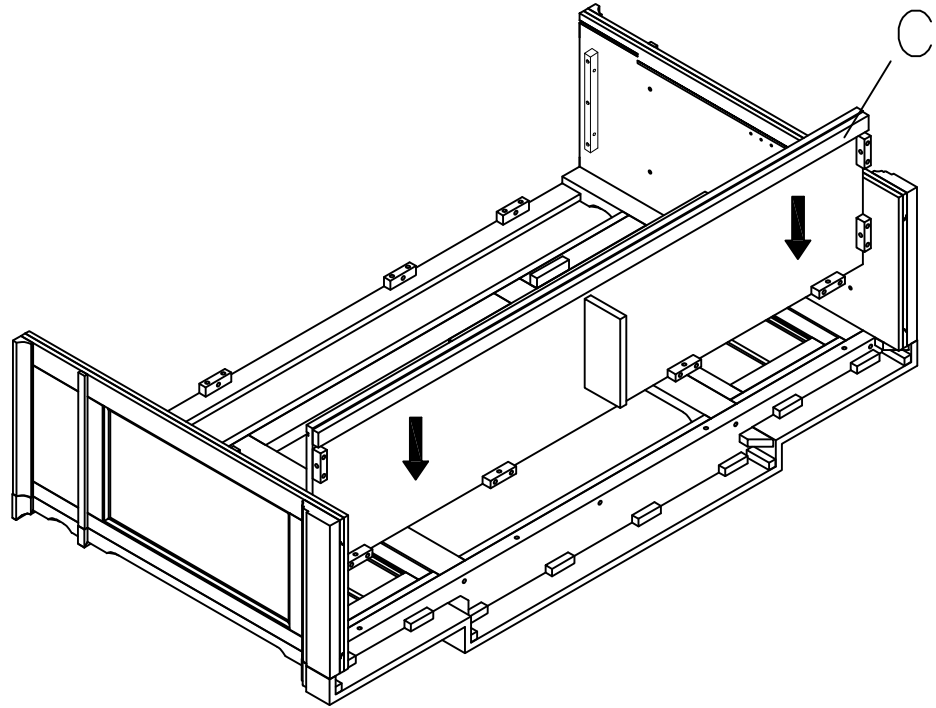

4

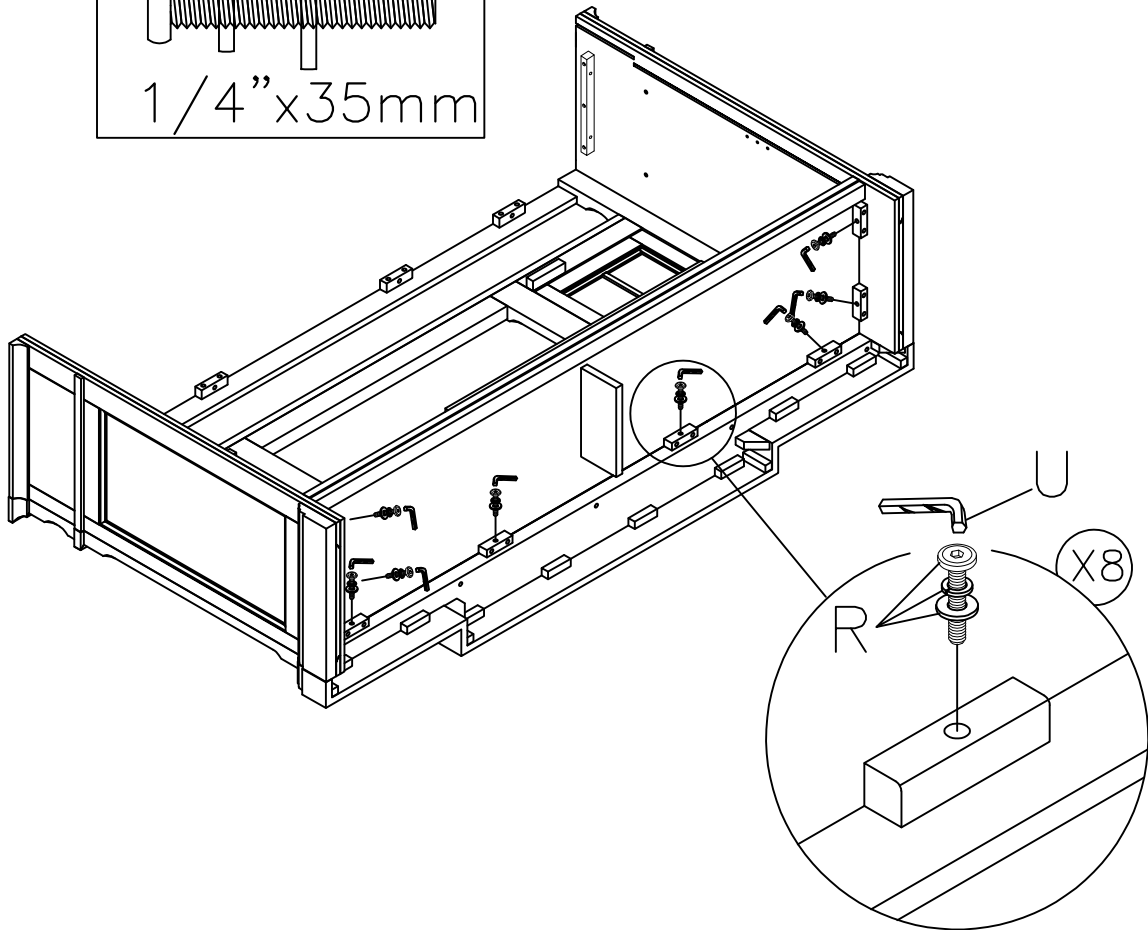
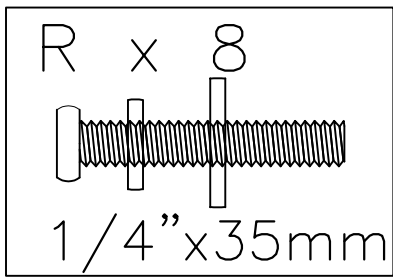

5

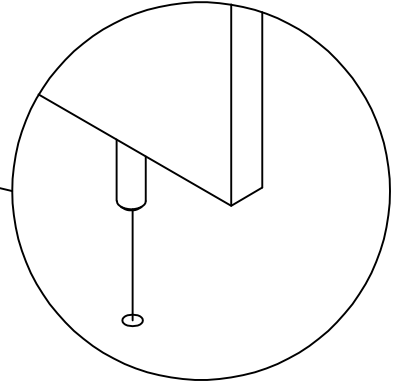
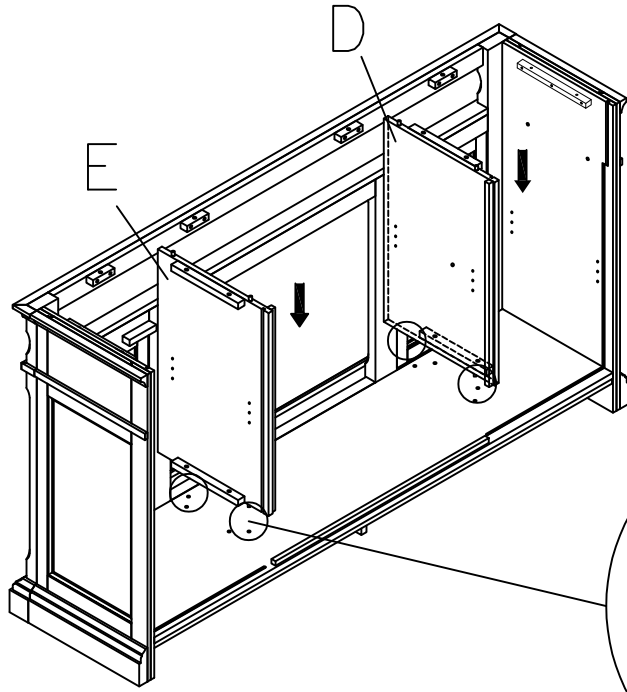

6

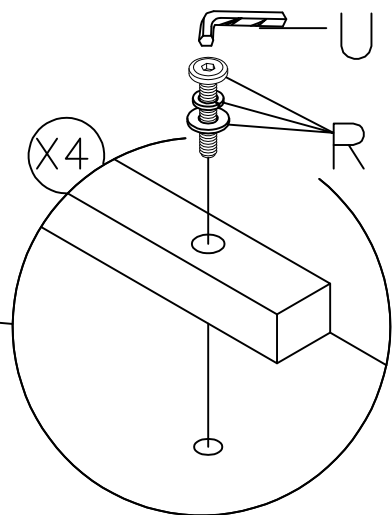
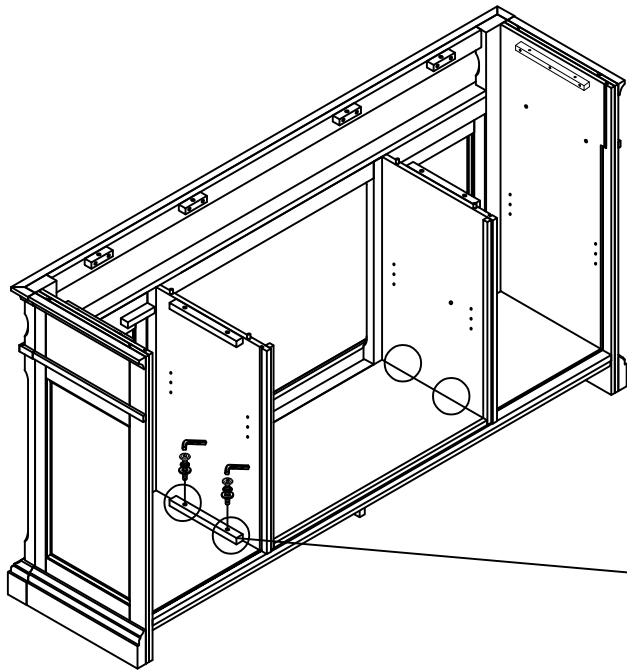
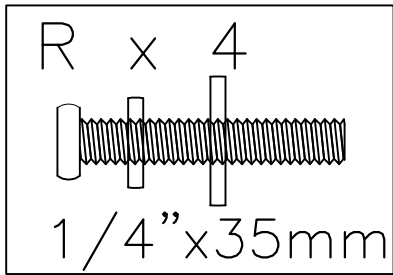

7

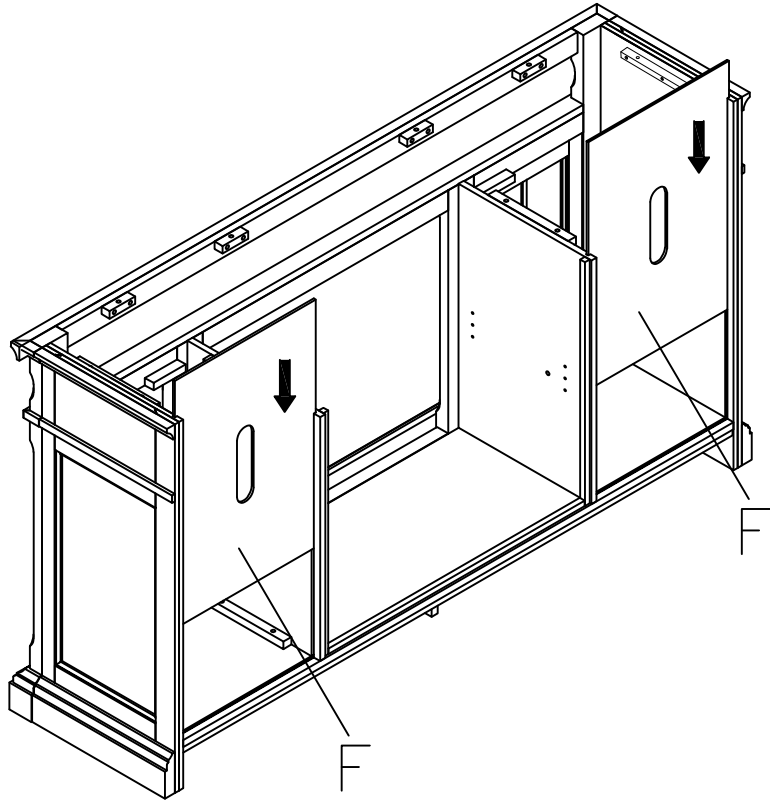

8

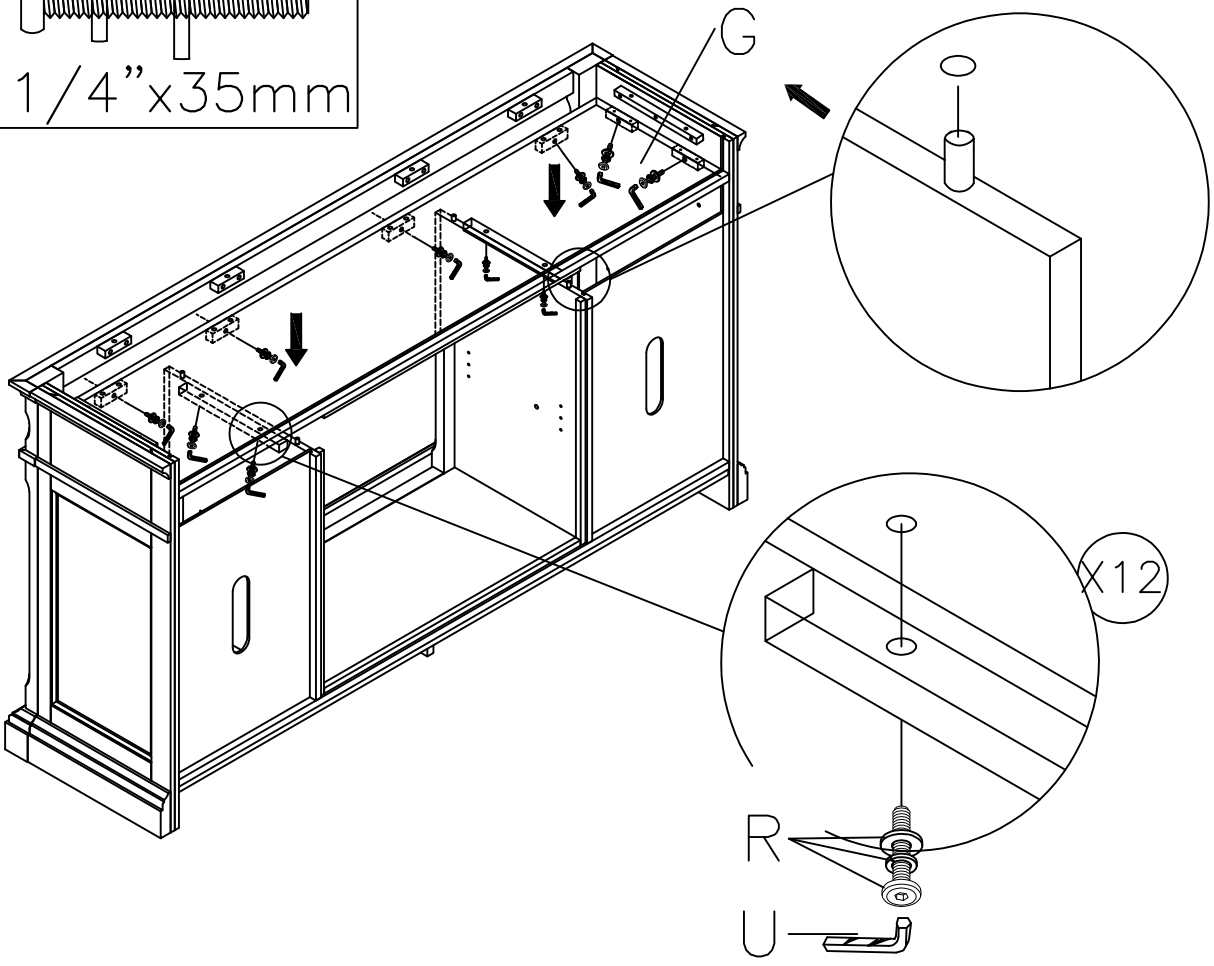
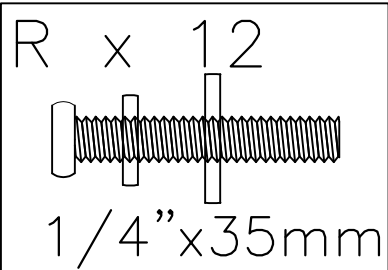

9

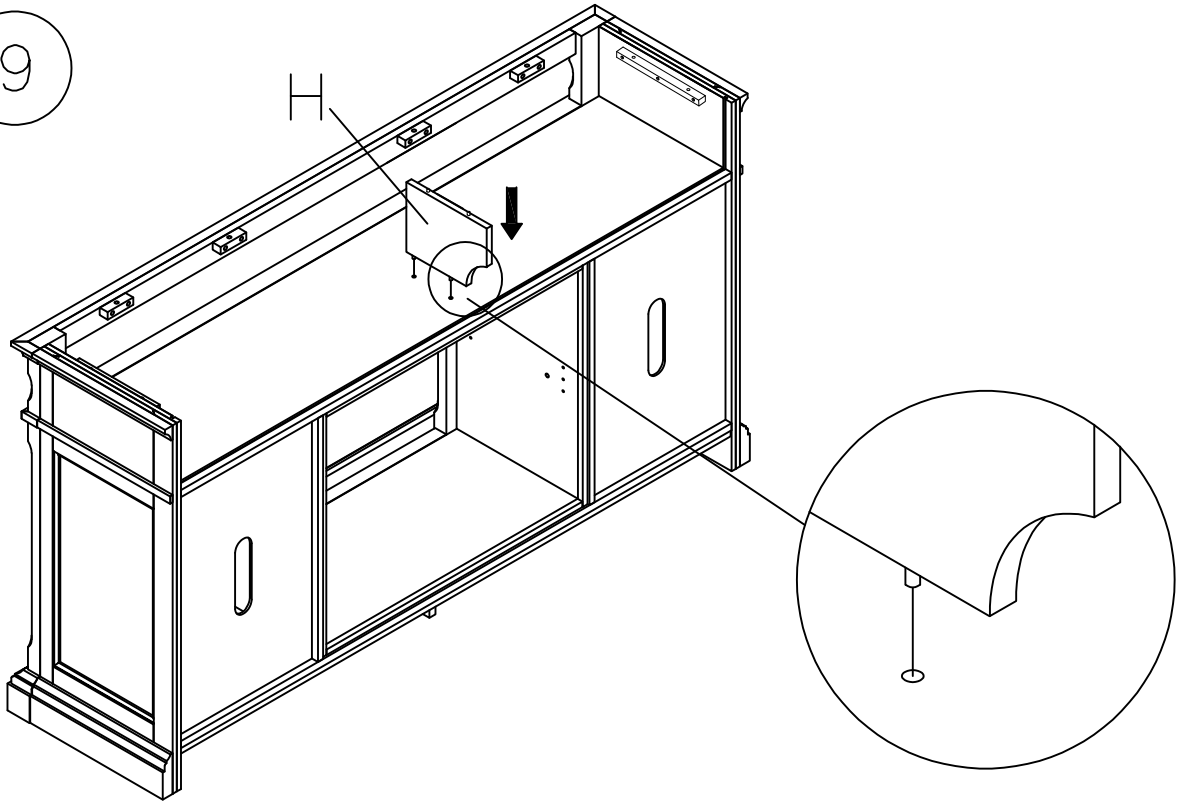

10

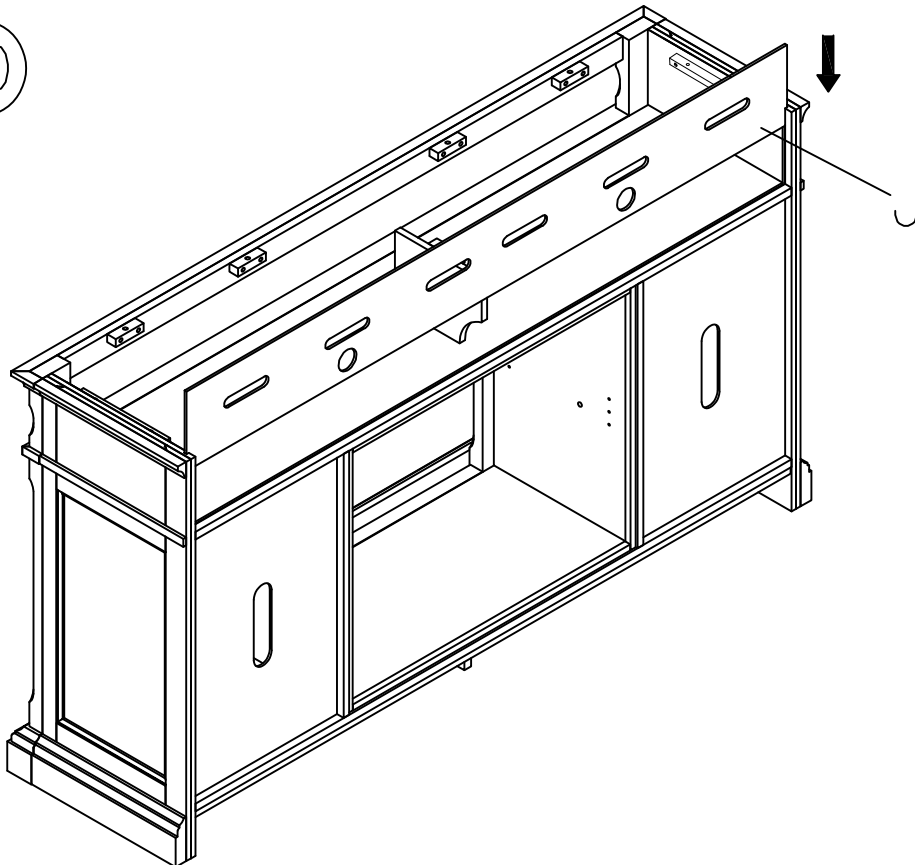

11

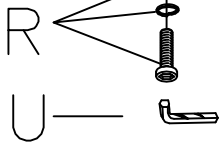
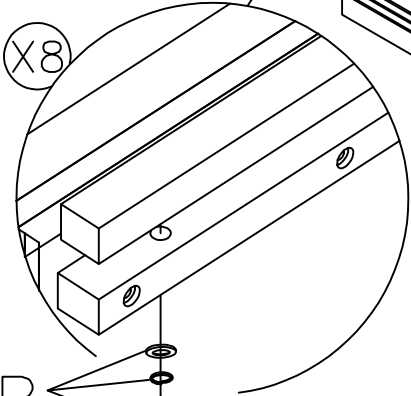
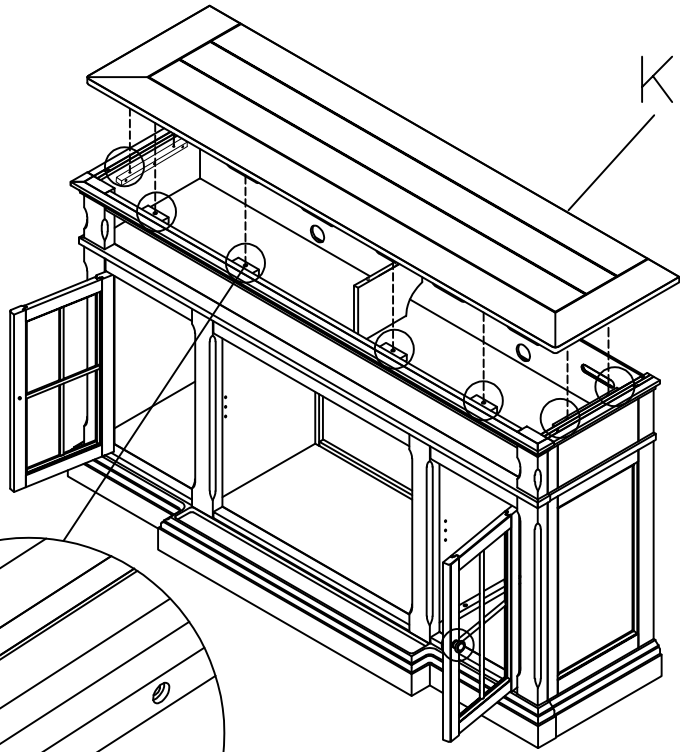
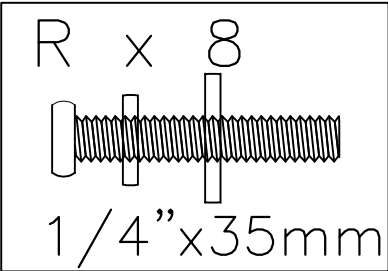

12

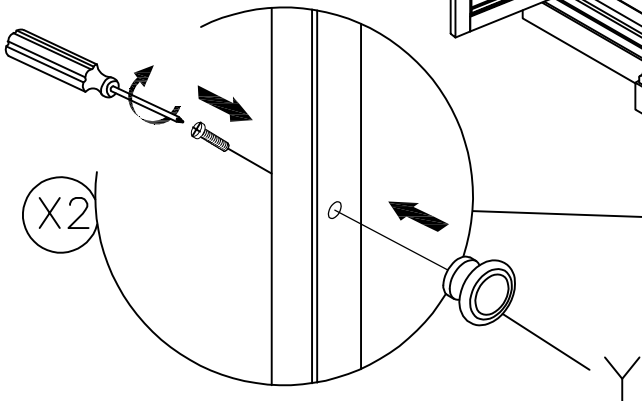
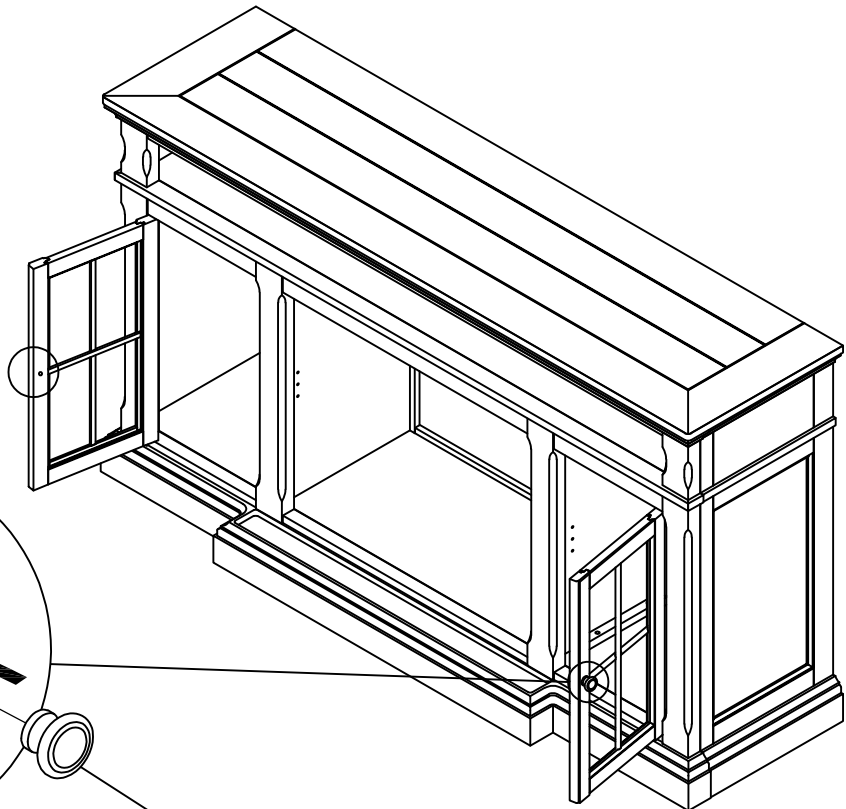
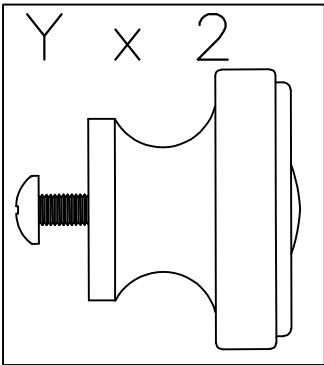

13

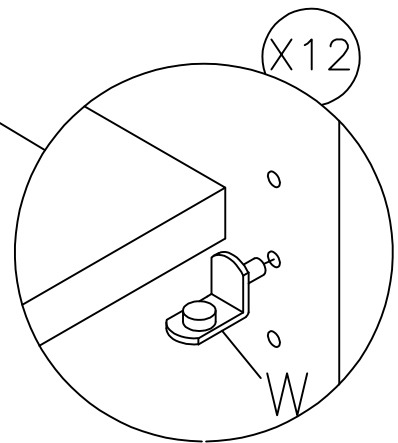
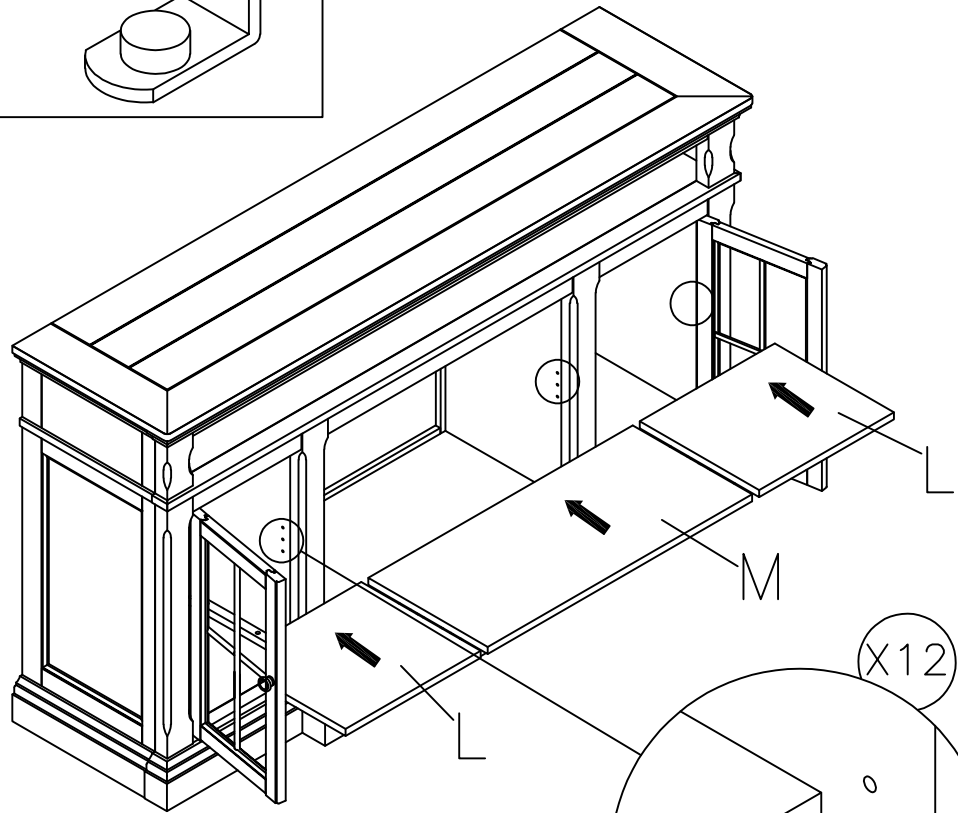
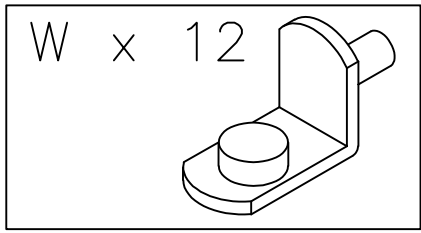

14

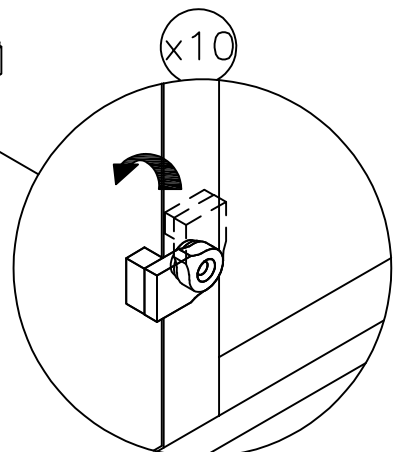
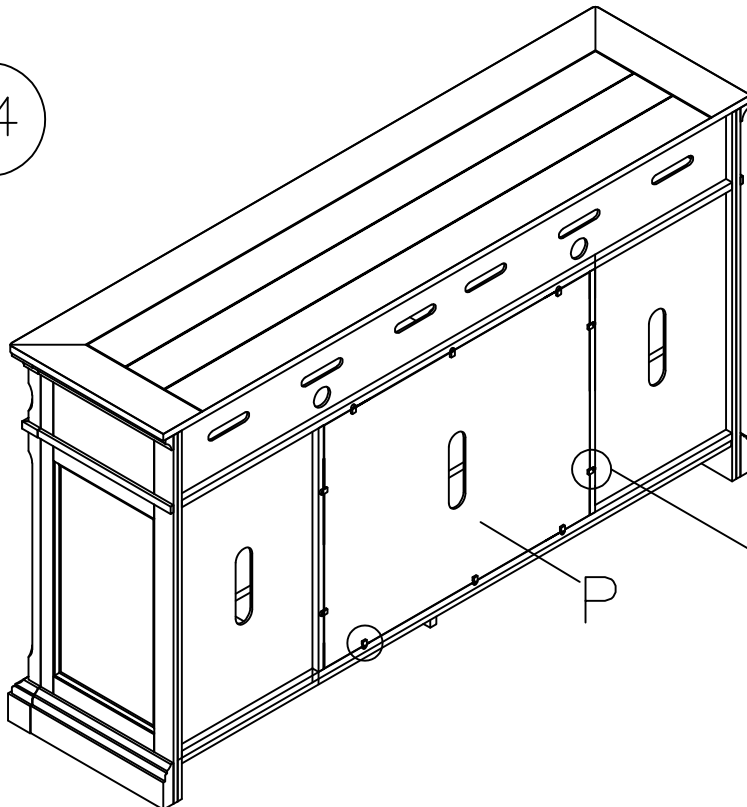

15

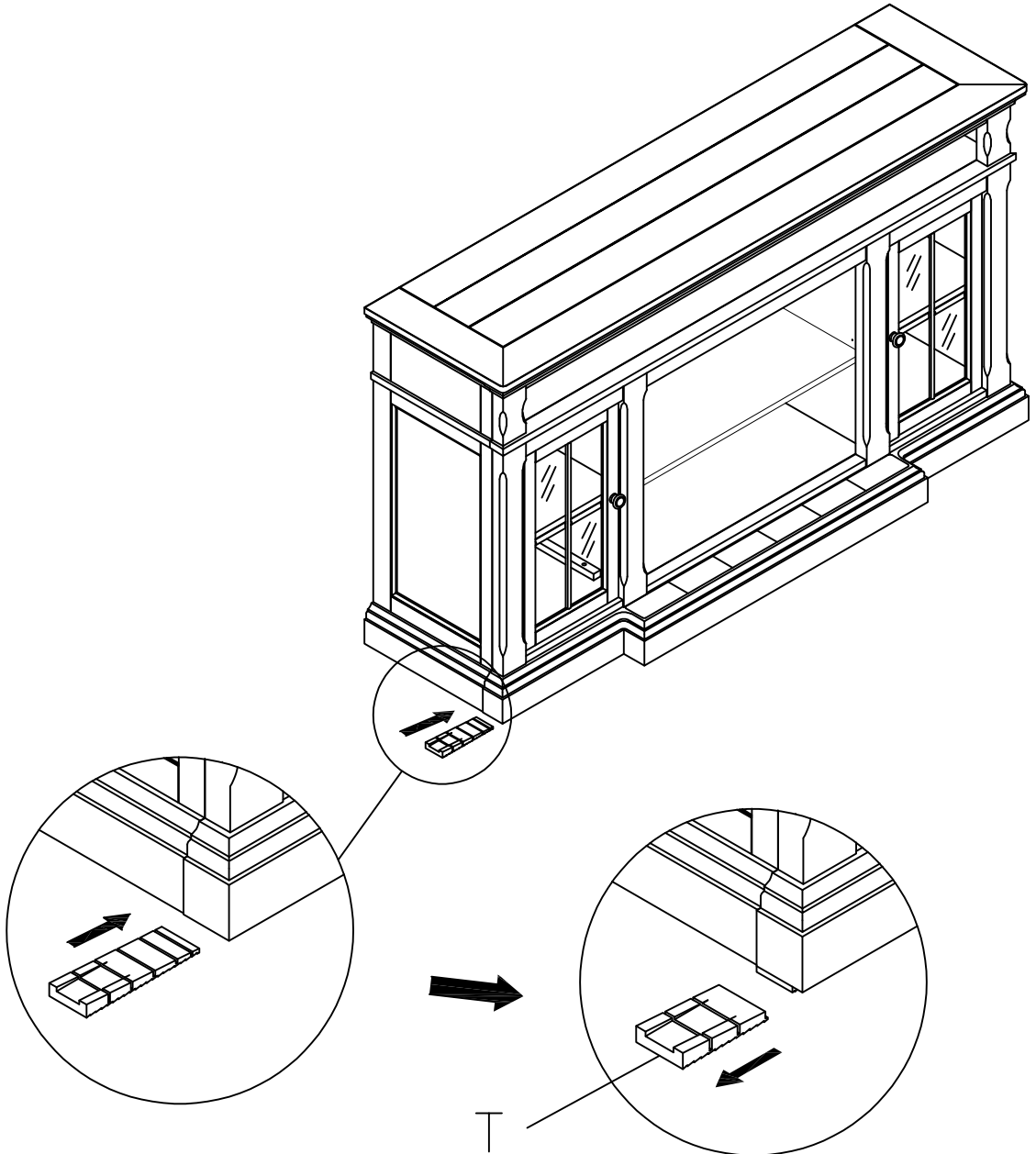
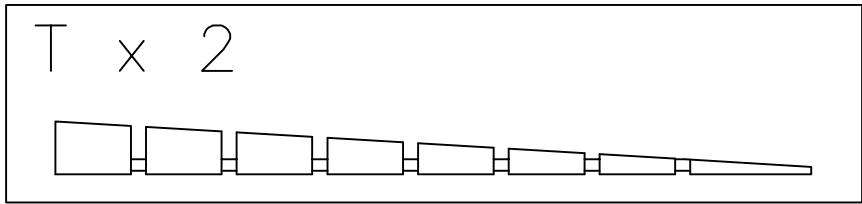

NOTE: IF THE UNIT IS PLACED ON AN UNLEVEL SURFACE, PLACE A LEVELER UNDERNEATH ONE FOOT UNTIL THE UNIT IS LEVEL. BREAK OFF ANY PROTRUDING SEGMENTS.

NOTA: EN CASO DE QUE EL DISPOSITIVO ESTÉ COLOCADO SOBRE UNA SUPERFICIE DESNIVELADA, PONGA UN NIVELADOR POR DEBAJO DE UNA PATA DE DISPOSITIVO HASTA QUE EL CUAL ESTÉ NIVELADO. ROMPA CUALQUIERA DE LOS SEGMENTOS QUE SOBRESALEN.

REMARQUE: SI L'UNITE EST PLACÉE SUR UNE SURFACE DE NON-NIVEAU, PLACEZ UN NIVELEUR SUR UNE PIE JUSQUE' A CETTE UNITE EST PLACÉE, ROMPREZ TOUT SEGMENTS SAILLANTS.

提醒：如果产品无法放水平，请在某一条腿下放置楔形脚垫。待家具放置水平之后，敲掉多余的部分

16

Z x 1

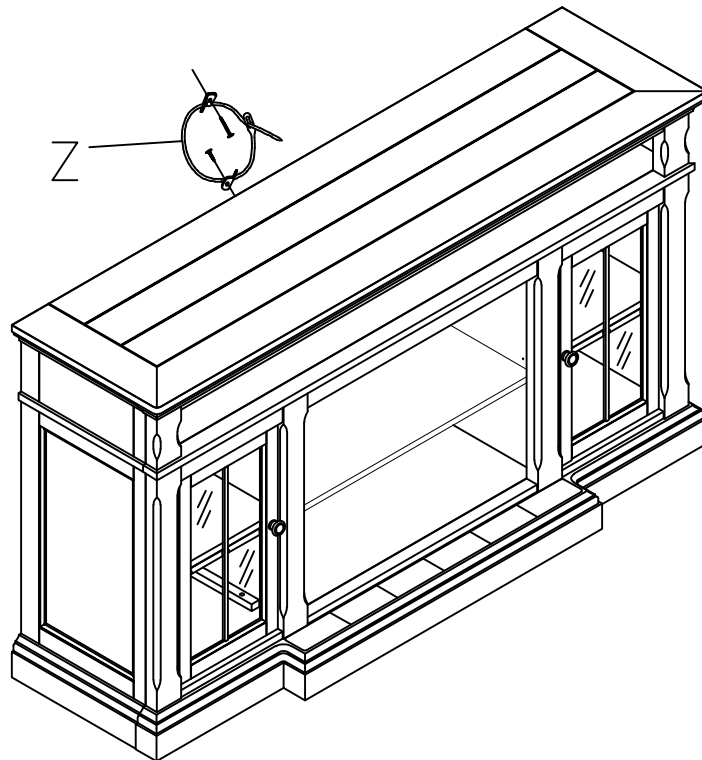
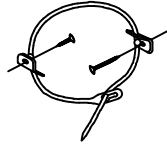

! WARNING !

The use of the included tipping restraint may reduce, but not eliminate, the risk of furniture tip over. Follow the instructions on the plastic bag for proper installation.

!ADVERTENCIA!

El uso del dispositivo diseñado para evitar que el mueble se dé la vuelta reduce pero no elimina el riesgo de que eso pueda suceder. Siga las instrucciones que hay en la bolsa plástica para la instalación adecuada.

! AVERTISSEMENT !

L'utilisation du système anti-bascule peut réduire, mais n'élimine pas, les risques de renversement du meuble. Suivez les instructions se trouvant sur le sac en plastique pour l'installer correctement.

! 警告 !

使用防倾倒装置只能降低但不能完全避免倾倒风险,安装此装置时请按照包装袋上的说明。

Optional / Opcional / Optionnel / 可选的

NOTE: When using the fireplace insert, please DO NOT use the optional back panel.

NOTA: Cuando estés utilizando el inserto de chimenea, por favor no utilice el panel posterior opcional.

REMARQUE: Lors de l'utilisation de la cheminée insert, N'UTILISEZ PAS le panneau arrière option.

注意：当使用火炉的时候，请不要安装背板。

17

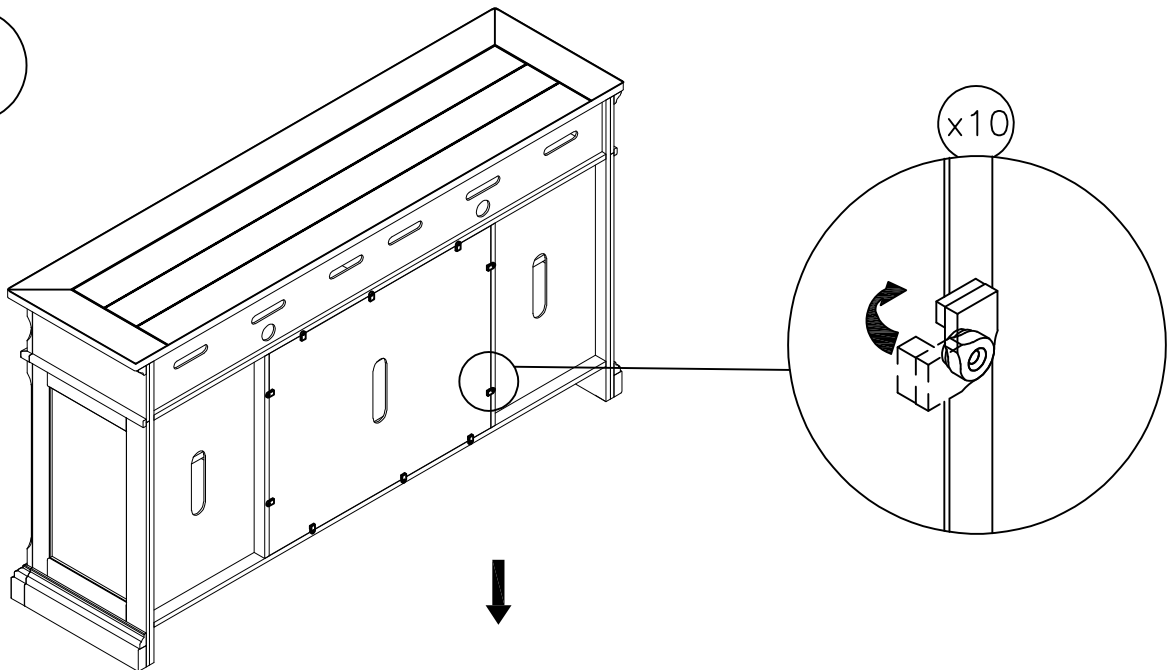

18

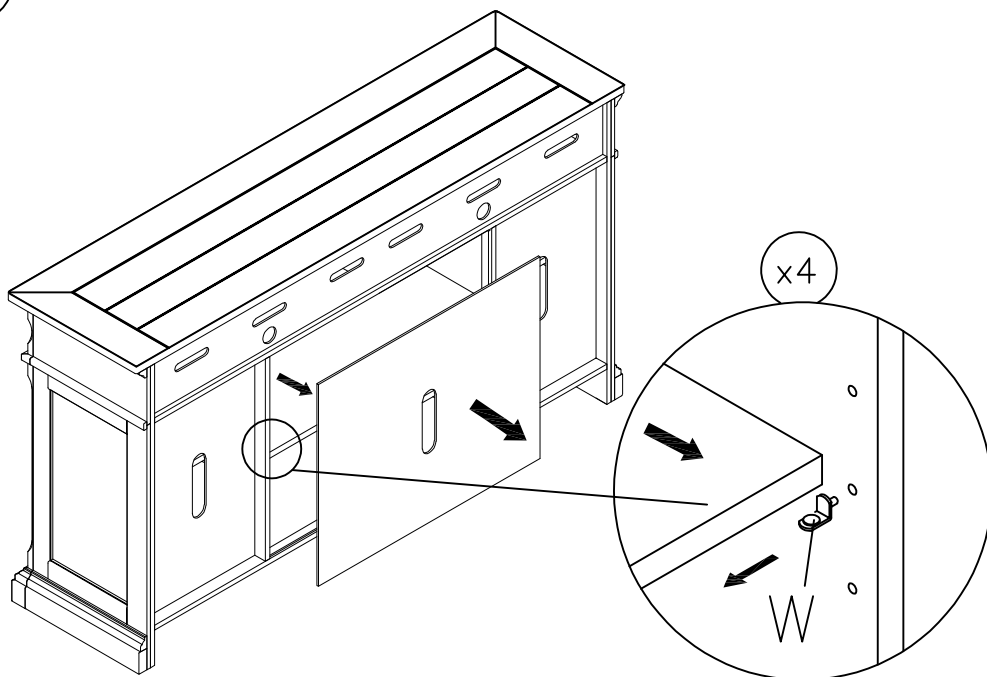

19

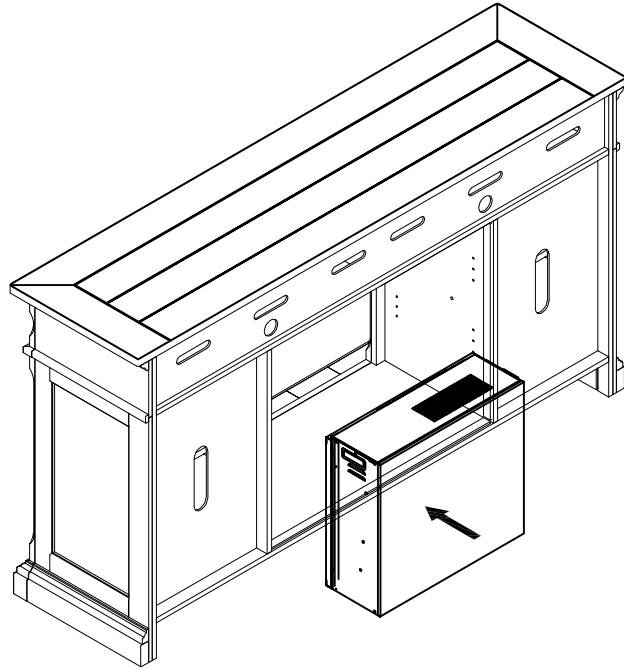

20

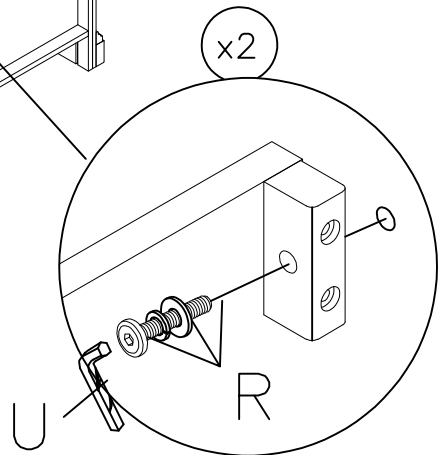
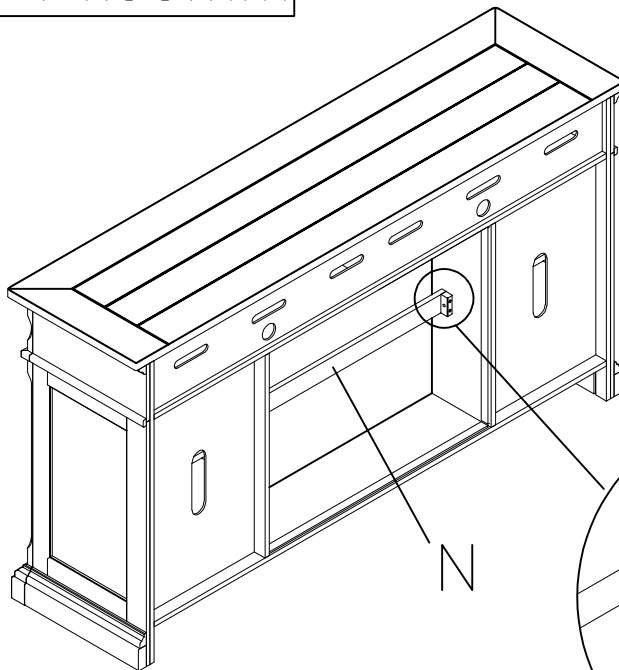
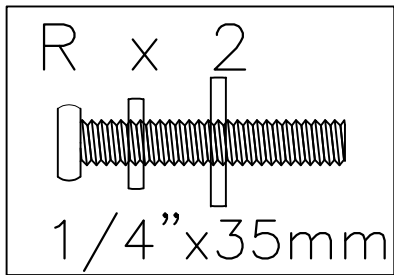

21

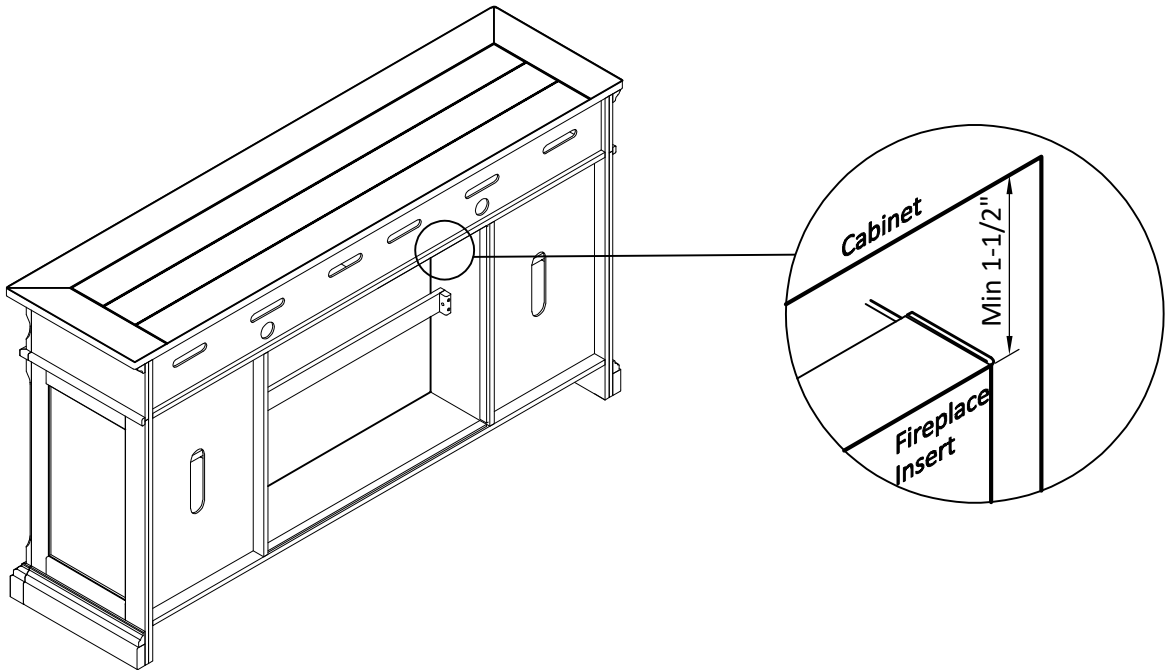

WARNING: The gap between the fireplace's top with any obstacles above it must be a minimum of 38 mm. Failure to provide a minimum of a 1-1/2" gap as instructed could result in a fire, bodily injury, death or property damage.



ADVERTENCIA: La brecha entre la parte superior de la estufa con cualquier obstáculo por encima de ella debe ser un mínimo de 1-1/2". Falta de proporcionar un mínimo de un espacio de 38 mm según las instrucciones podría resultar en un incendio, lesiones y muerte o daños materiales.



AVERTISSEMENT: L'espace entre le dessus du foyer et tout obstacle se trouvant au-dessus doit être d'un minimum de 1-1/2". Le fait de ne pas laisser un espace d'un minimum de 38 mm, tel qu'il a été instruit, pourrait entraîner un feu, des blessures, la mort ou des dommages matériels.



警告: 壁炉的顶部距离上面障碍物必需保持至少1-1/2"的空隙, 如果违背说明书低于38mm, 可能会导致火灾, 财产损失, 身体伤害或死亡。

22

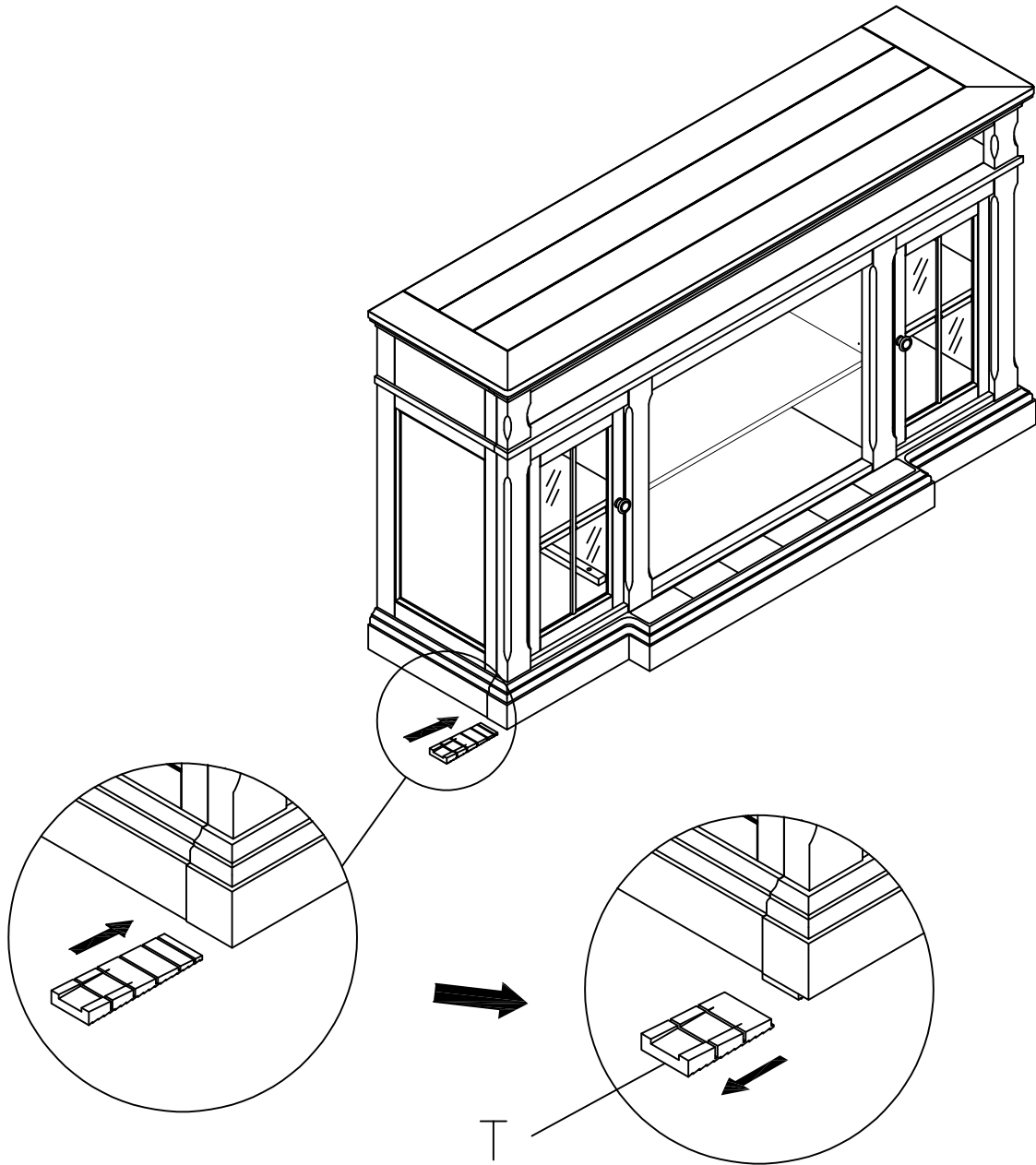
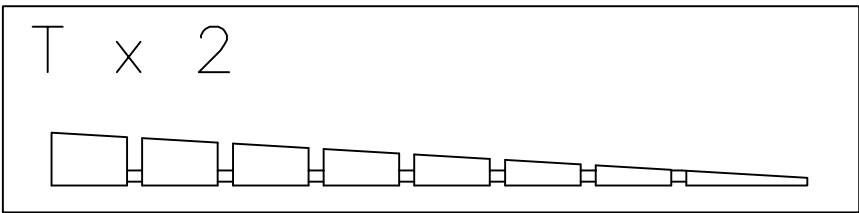

NOTE: IF THE UNIT IS PLACED ON AN UNLEVEL SURFACE, PLACE A LEVELER UNDERNEATH ONE FOOT UNTIL THE UNIT IS LEVEL. BREAK OFF ANY PROTRUDING SEGMENTS.

NOTA: EN CASO DE QUE EL DISPOSITIVO ESTÉ COLOCADO SOBRE UNA SUPERFICIE DESNIVELADA, PONGA UN NIVELADOR POR DEBAJO DE UNA PATA DE DISPOSITIVO HASTA QUE EL CUAL ESTÉ NIVELADO. ROMPA CUALQUIERA DE LOS SEGMENTOS QUE SOBRESALEN.

REMARQUE: SI L'UNITE EST PLACEE SUR UNE SURFACE DE NON-NIVEAU, PLACEZ UN NIVELEUR SUR UNE PIE JUSQUE' A CETTE UNITE EST PLACEE, ROMPREZ TOUT SEGMENTS SAILLANTS.

提醒：如果产品无法放水平，请在某一条腿下放置楔形脚垫。待家具放置水平之后，敲掉多余的部分

23

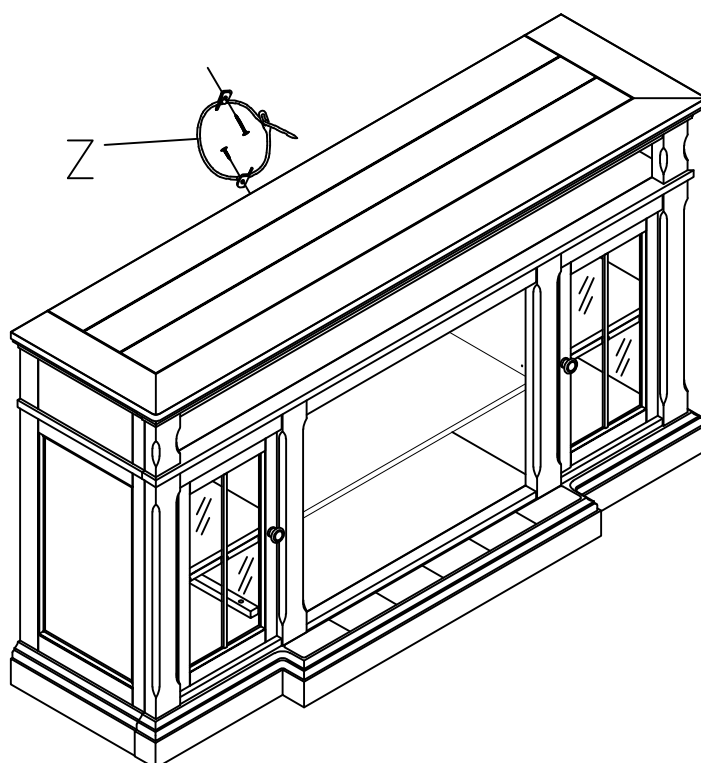
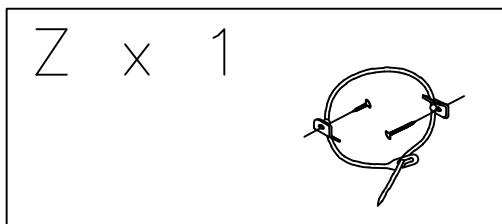

! WARNING !

The use of the included tipping restraint may reduce, but not eliminate, the risk of furniture tip over. Follow the instructions on the plastic bag for proper installation.

!ADVERTENCIA!

El uso del dispositivo diseñado para evitar que el mueble se dé la vuelta reduce pero no elimina el riesgo de que eso pueda suceder. Siga las instrucciones que hay en la bolsa plástica para la instalación adecuada.

! AVERTISSEMENT !

L'utilisation du système anti-basculade peut réduire, mais n'élimine pas, les risques de renversement du meuble. Suivez les instructions se trouvant sur le sac en plastique pour l'installer correctement.

! 警告 !

使用防倾倒装置只能降低但不能完全避免倾倒风险,安装此装置时请按照包装袋上的说明。