

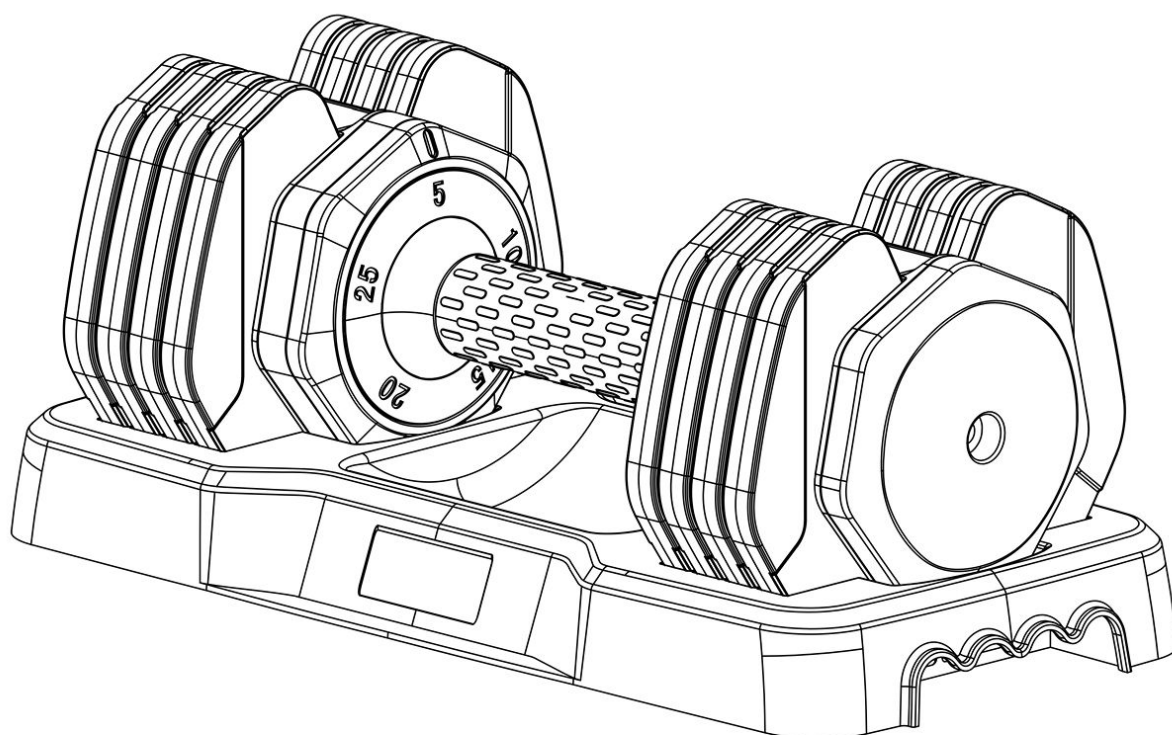

Adjustable Dumbbell Set

25 / 55lbs

User Manual



Safety Instruction

 **Warning:** To prevent accidents, please read the following carefully before using adjustable dumbbells. We will not be responsible for personal injury or property loss caused by the use of this product. Please make sure read all the information below and keep this manual for reference.

1. When using adjustable dumbbells, step by step to avoid unnecessary damage.
2. In order to achieve obvious exercise effect and not cause excessive burden on muscles, the number of exercises should be controlled within a reasonable range.
3. If the equipment is found to have problems such as wear, screw loss, rust, etc., it should be repaired or replaced in time to ensure that all parts are always in good condition.
4. Please keep pets and children away from this device. The minimum age for using this device is 15 years old.
5. Stop exercising immediately in the event of nausea, shortness of breath, dizziness, chest tightness or any discomfort.
6. Before exercising, consult your doctor about the frequency, time, and intensity of stimulation that is appropriate for your specific age and conditions.
7. Do not turn the weight selection dial when the dumbbell or handle is lifted from the dumbbell tray.
8. When choosing the weight adjustment, the dumbbell group can only be lifted when the clear card position "sound" of each segment is heard and the handle is parallel to the corresponding scale indication mark.

Included Items

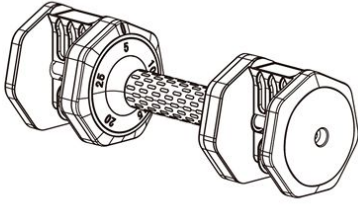

Handlegrip

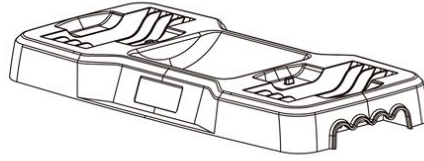

Dumbbell Tray



Dumbbell Plate

Instruction

1. Choose Weight

Turn the handlegrip and make the pointer points to the number (Weights). At this point, the handlegrip will jam the corresponding weight of dumbbell plate.

Note: Make sure that you hear a click before picking up the dumbbell.

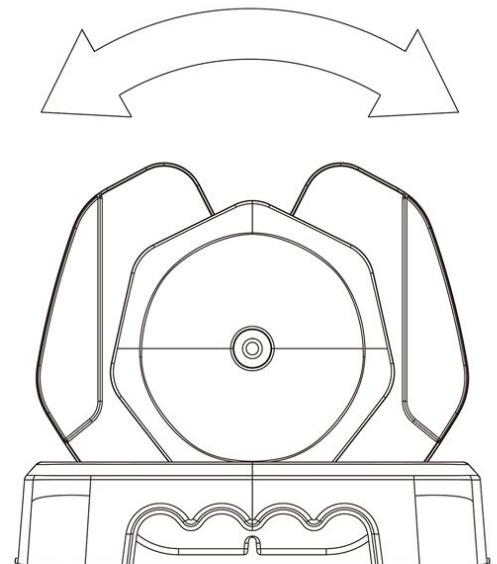
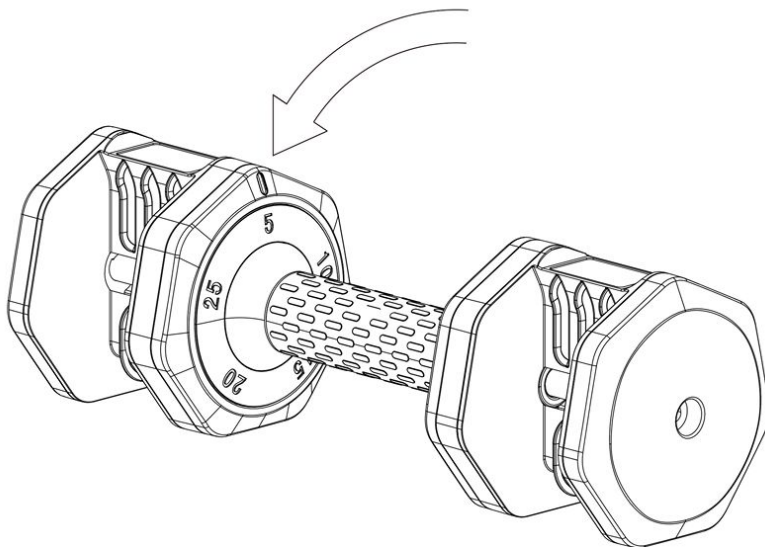

2.Place Dumbbell Plate

To keep balance, the dumbbell plate should be evenly distributed on the same groove on both sides.

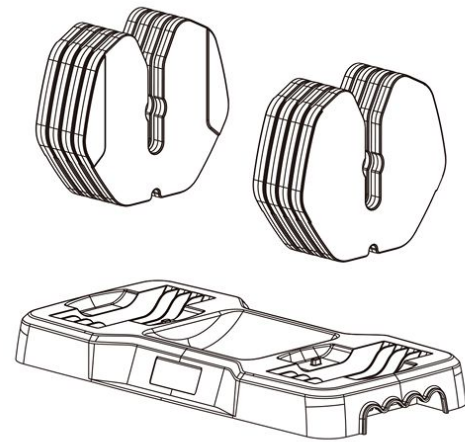
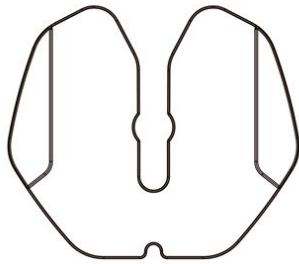

Operation diagram

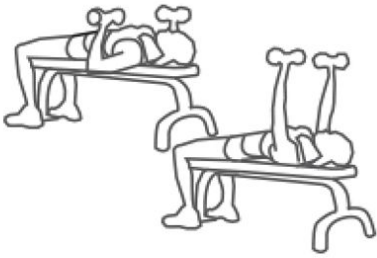

Dumbbell bench press



Incline dumbbell fly

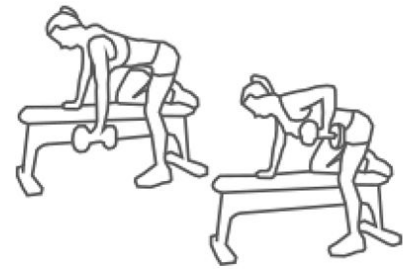

One -arm dumbbell fly



Reverse dumbbell fly

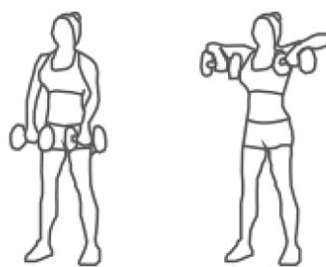

Standing dumbbell row

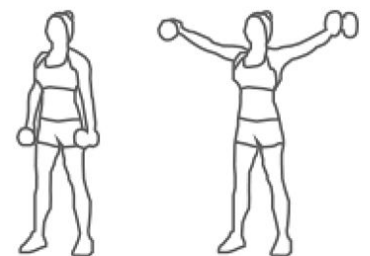

Dumbbell lateral raise

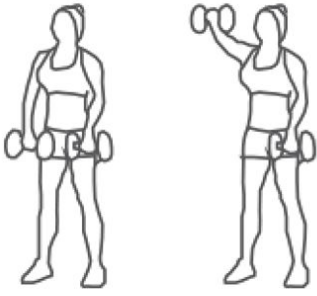

Front dumbbell raise

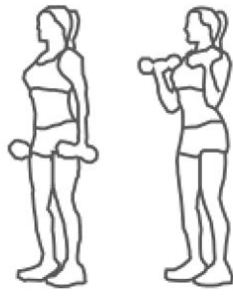

Standing dumbbell curl

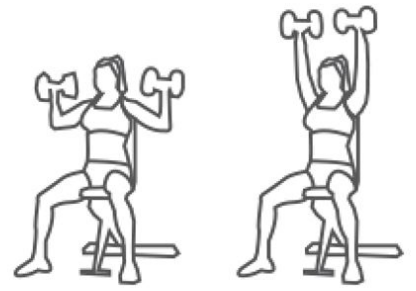

Seated dumbbell press

Training suggestion

Choose your exercise intensity according to training difficulty, training time, etc. If you need to know more about training movements, please browse professional exercise instructions manuals, books, videos or consult a personal trainer to learn about the correct use of posture, skills and exercise methods.

Notice: Please feel free to contact us if there are some problems with our item (like damaged, missing screws etc.) we can help you to solve (return, replace, repair).