

ASSEMBLY INSTRUCTIONS

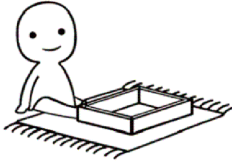

IMPORTANT INFORMATION!

please read the entire manual before starting to assemble and/or using this product. follow the manual thoroughly and keep it for further reference.



AVOID SCRATCHES!

In order to avoid scratching this furniture should be assembled on a soft layer—could be a rug.

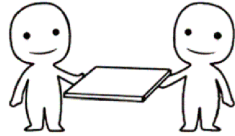



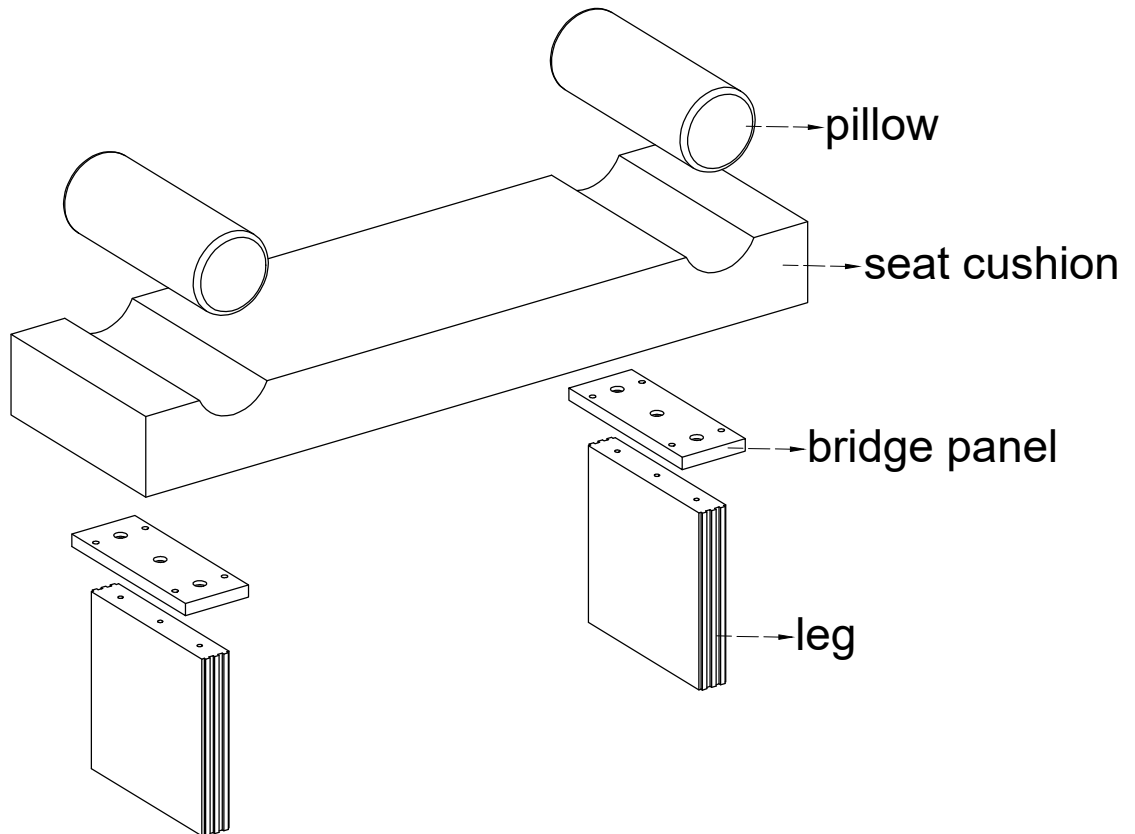
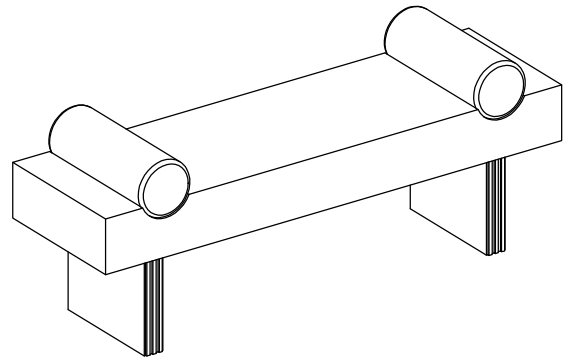

IMPROVE EFFICIENCY!

Try to find a partner to install with you, which can speed up the installation efficiency and shorten the time.



HARDWARE LIST

A		Bolt (Ø5/16"*1-3/4")	6pcs
B		Lock Washer (Ø5/16")	6pcs
C		Flat Washer (Ø5/16"*Ø3/4")	6pcs
D		Allen Wrench (5mm)	1pc
F		Foot Pad	4pcs

Step 1

bridge panel
unbolt

detach

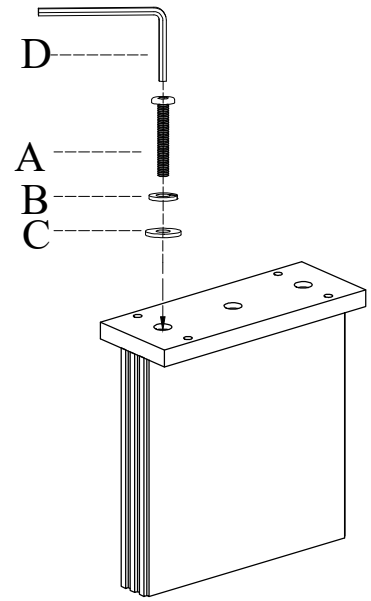
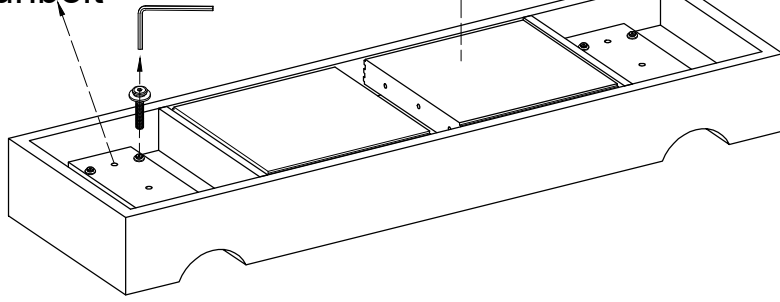

Step 2

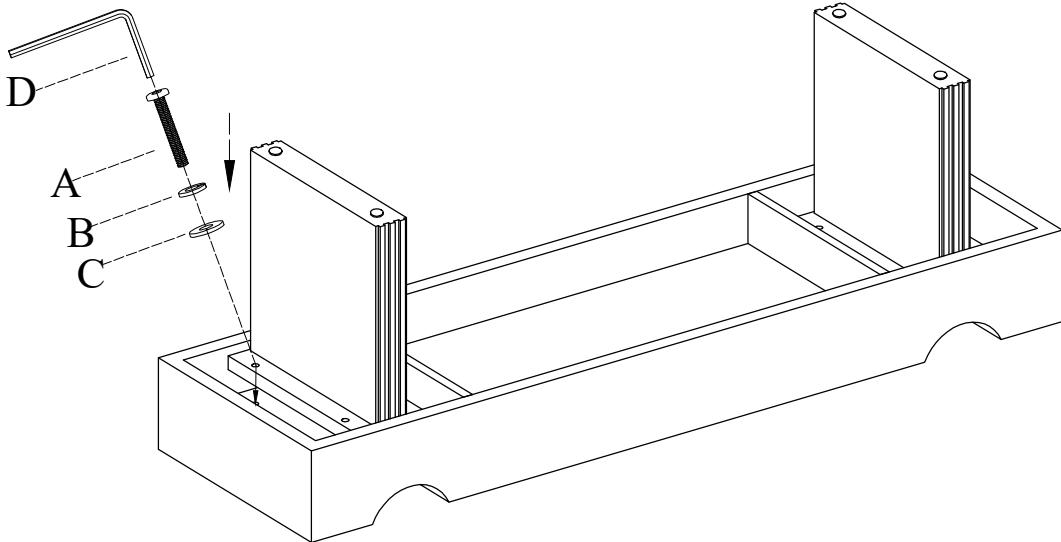

Step 3

