

# Assembly instruction!

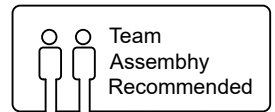

## Trouble shooting:

Missing/Wrong /Broken parts and installation issues

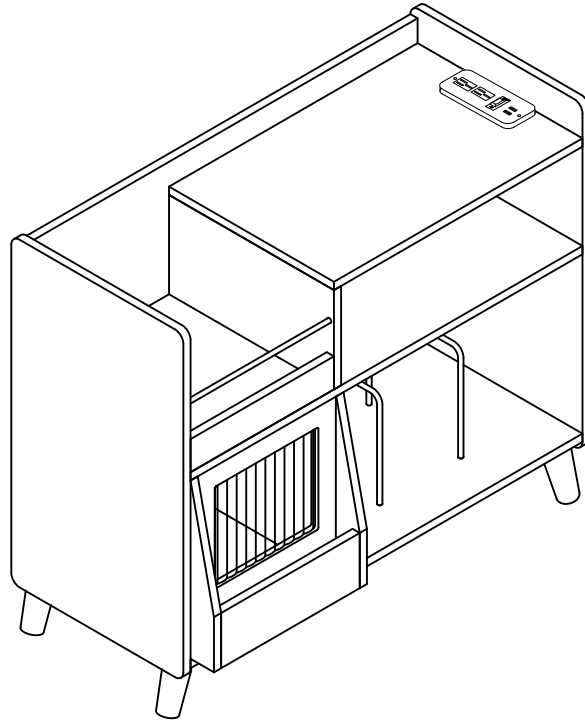

Send email with your question pic, order NO. and screenshot of order details.



Respond within 24 hours



Issue resolved

## Tips!



1. Check all the components & screws are intact before assembling .
2. If you notice any pieces are missing or damaged please do not assemble and contact us immediately .
3. **Please send an email with you order number and issues, we will respond within 24 hours.**

## Tools required

A Phillips head screw driver is required for the assembly of this product. (not included)  
Electric tool should not be used to assemble this product.

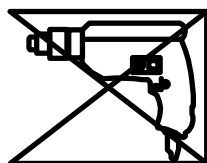
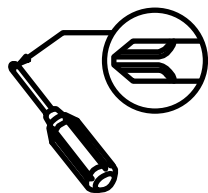

**Two people are needed**



## IMPORTANT SAFETY INFORMATION

- Please carefully read the following instructions and caution warnings before assembling the product.
- Following this guide will ensure that you install, use and maintain the product properly.
- Please keep this installation and user manual/instructions for future reference in case you need to disassemble the product.
- Never allow children to climb onto the product. Ensure that you have special safety measures when children are around on their own.
- Be sure to check that all parts of the product are intact after you open the package.
- Do not assemble if you notice serious damage such as cracks or bends.
- During installation, please use work gloves for hand safety.
- Please assemble the unit on carpeted floor or the flat cardboard box to avoid scratching the surface or your floor while assembling on the floor.
- To assemble, please use the complimentary installation tools (Phillips screwdriver). Pay more attention to the direction of components at each steps.
- It is recommended that two people work together to assemble the product.

## RETURN POLICY

- Please contact us directly within 30 days after receiving.
- Ensure the product is in a good condition with the original box and all original certificates of purchase, manuals, and accessories attached.

Please check that you have all the parts listed below

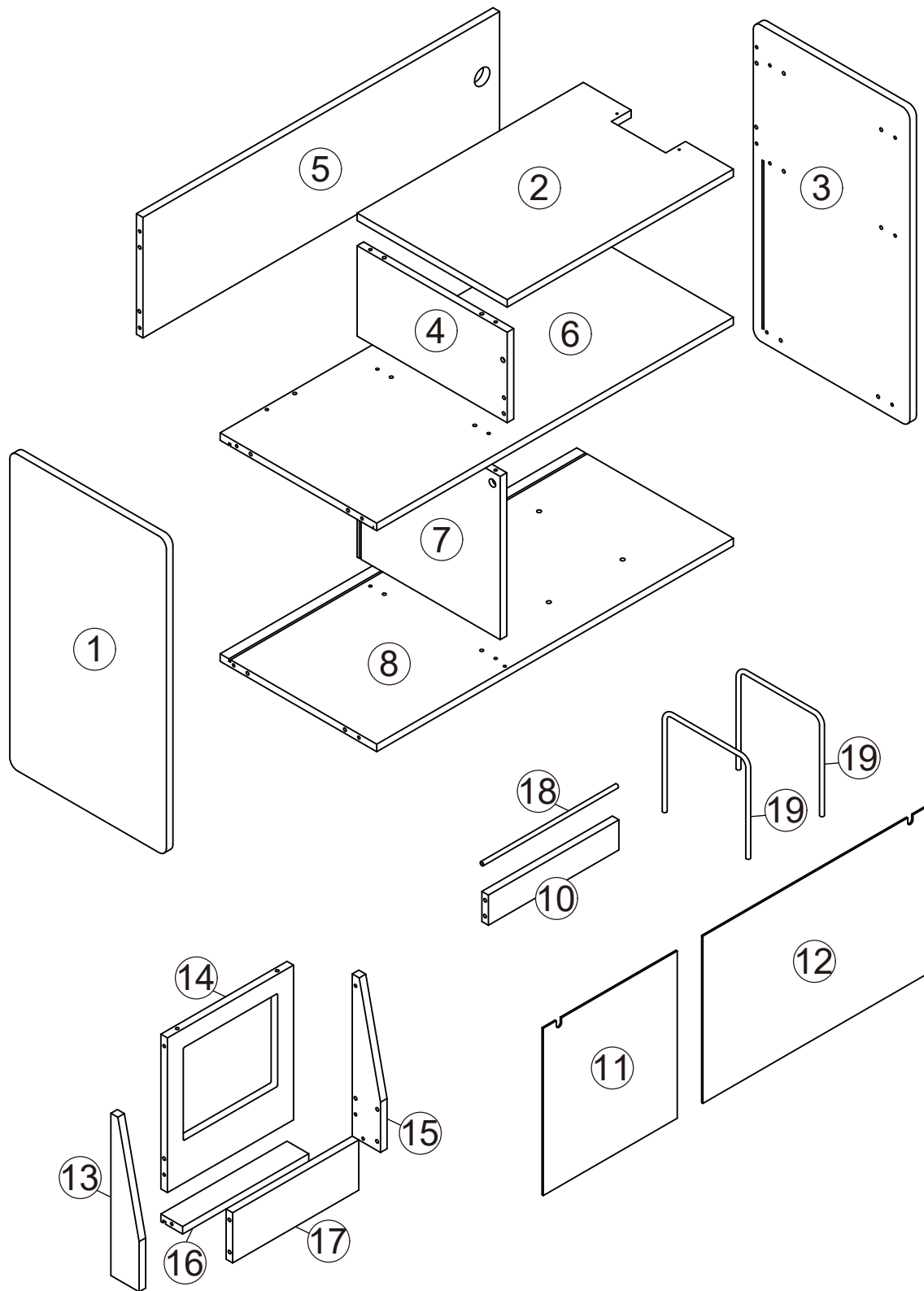

**Note: Don't tighten all screws during installation.**

## Components:

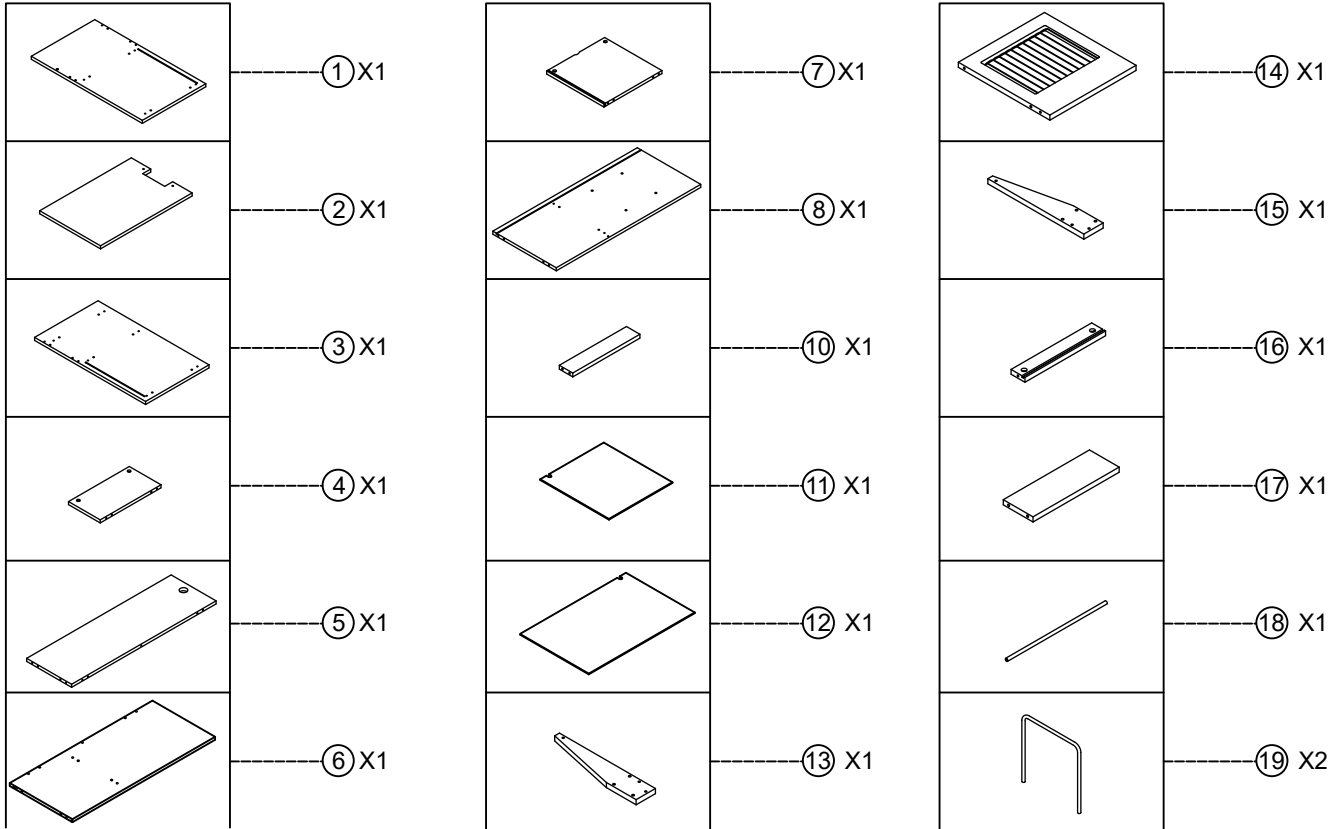



## Screws & Tools:

Ⓐ		Ø6x35 mm	27pcs
Ⓑ		Ø15x9 mm	27pcs
Ⓒ		Ø8x30 mm	18pcs
Ⓓ		Ø4x35 mm	4pcs
Ⓔ		Ø5x25 mm	4pcs
Ⓕ		65x70 mm	4pcs

Ⓖ		Ø4x14 mm	20pcs
Ⓗ		Ø35x175 mm	4pcs
Ⓘ			1pc
Ⓙ		L650 mm	1pc
Ⓚ		Ø6x30 mm	16pcs
Ⓛ		Ø5x12 mm	3pcs
Ⓜ			2pcs
Ⓝ	BLACK	Ø4x14 mm	2pcs
Ⓞ			1pc

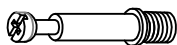

Check all the components & screws before assembly.  
Do not install in case part is missing, contact us to get.  
We will resend within 24 hours.

# Step 1

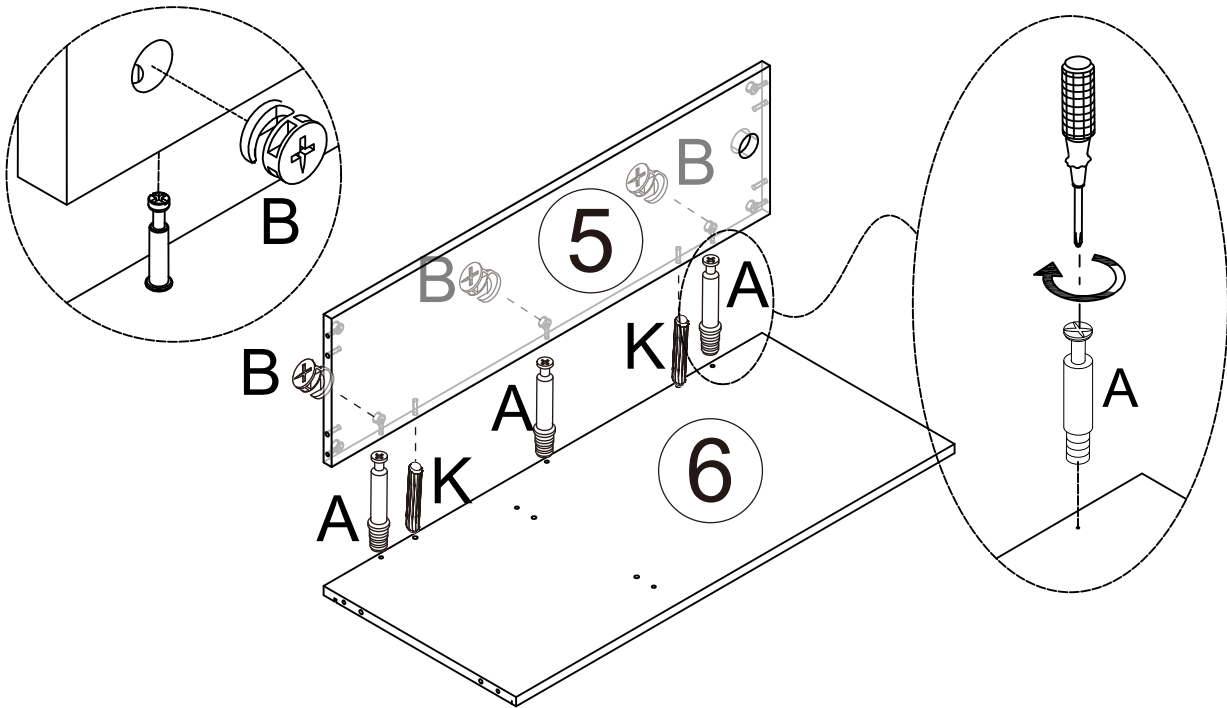
<p><b>A</b> x 3pcs</p>  <p>Ø6x35 mm CAM STUD</p>	<p><b>B</b> x 3pcs</p>  <p>Ø15x9 mm CAM LOCK</p>	<p><b>K</b> x 2pcs</p>  <p>Ø6x30 mm DOWEL</p>
--	---	--



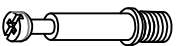

# Step 2

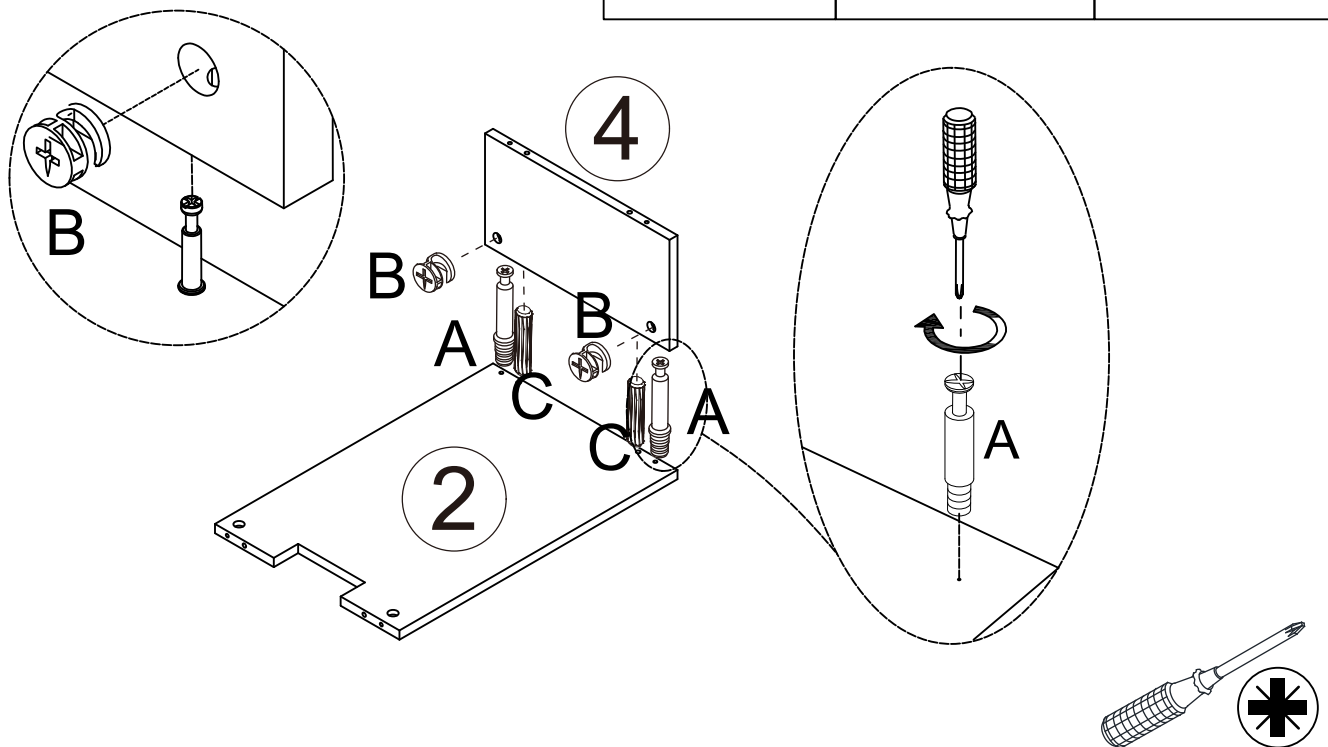
<p><b>A</b> x 2pcs</p>  <p>Ø6x35 mm CAM STUD</p>	<p><b>B</b> x 2pcs</p>  <p>Ø15x9 mm CAM LOCK</p>	<p><b>C</b> x 2pcs</p>  <p>Ø8x30 mm DOWEL</p>
--	---	--



# Step 3

<b>C</b> x 2pcs  Ø8x30 mm DOWEL	<b>D</b> x 2pcs  Ø4x35 mm SCREW
--	--

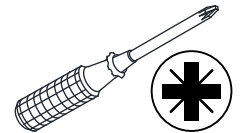
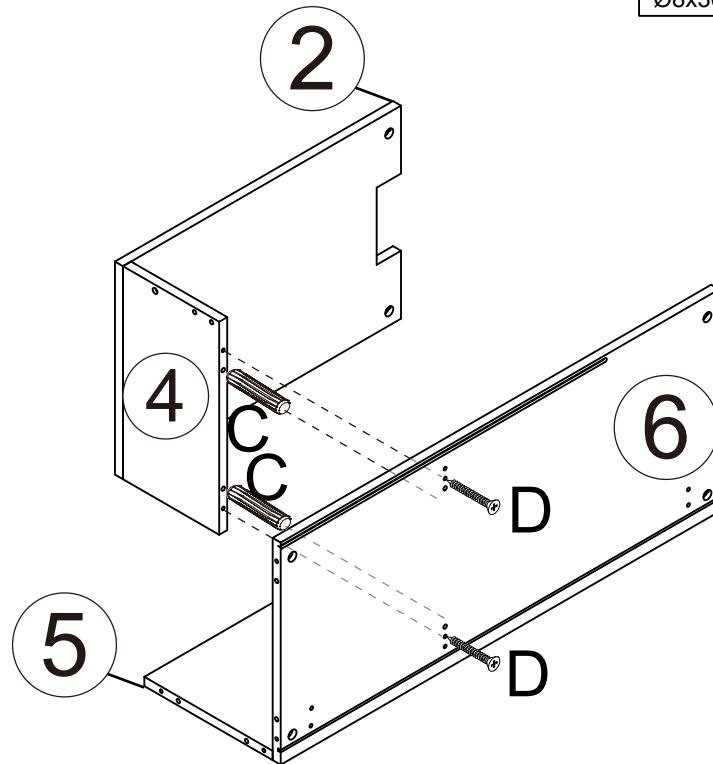

# Step 4

<b>J</b> x 1pc  L650 mm LIGHT STRIP
--

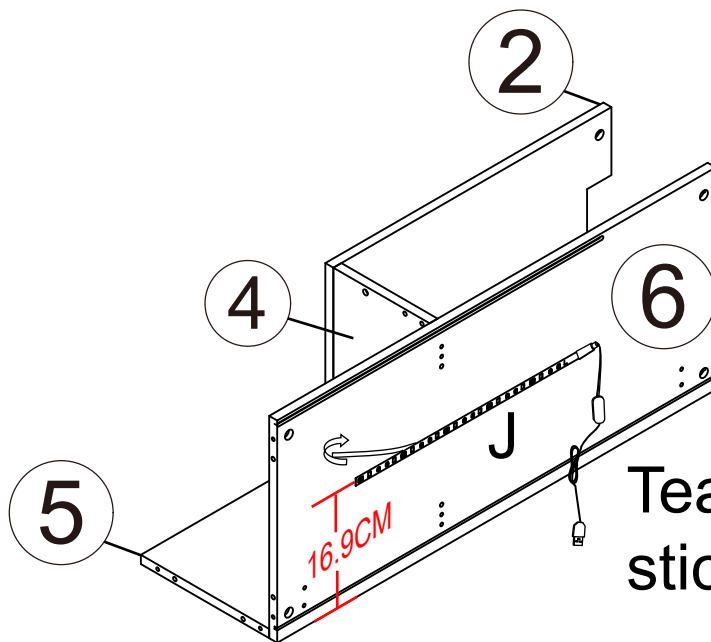



Tear the tape and stick it on Board 6.

**Note:**The light strip is 16.9CM from the edge of the board.

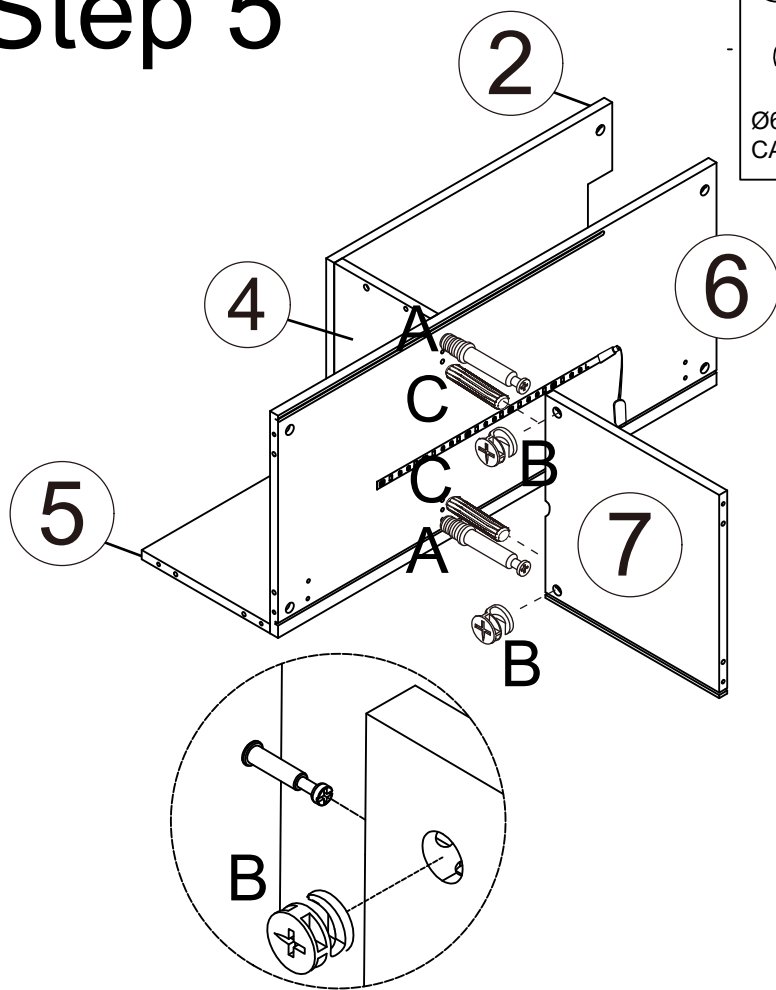
# Step 5

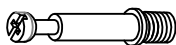

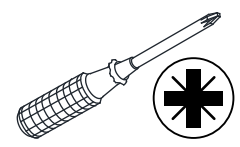
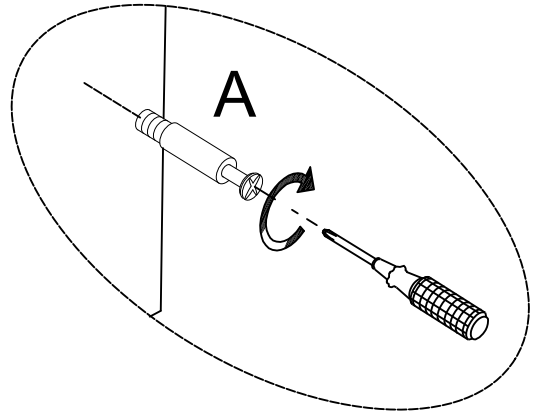

<p><b>A</b> x 2pcs</p>  <p>Ø6x35 mm CAM STUD</p>	<p><b>B</b> x 2pcs</p>  <p>Ø15x9 mm CAM LOCK</p>	<p><b>C</b> x 2pcs</p>  <p>Ø8x30 mm DOWEL</p>
--	---	--

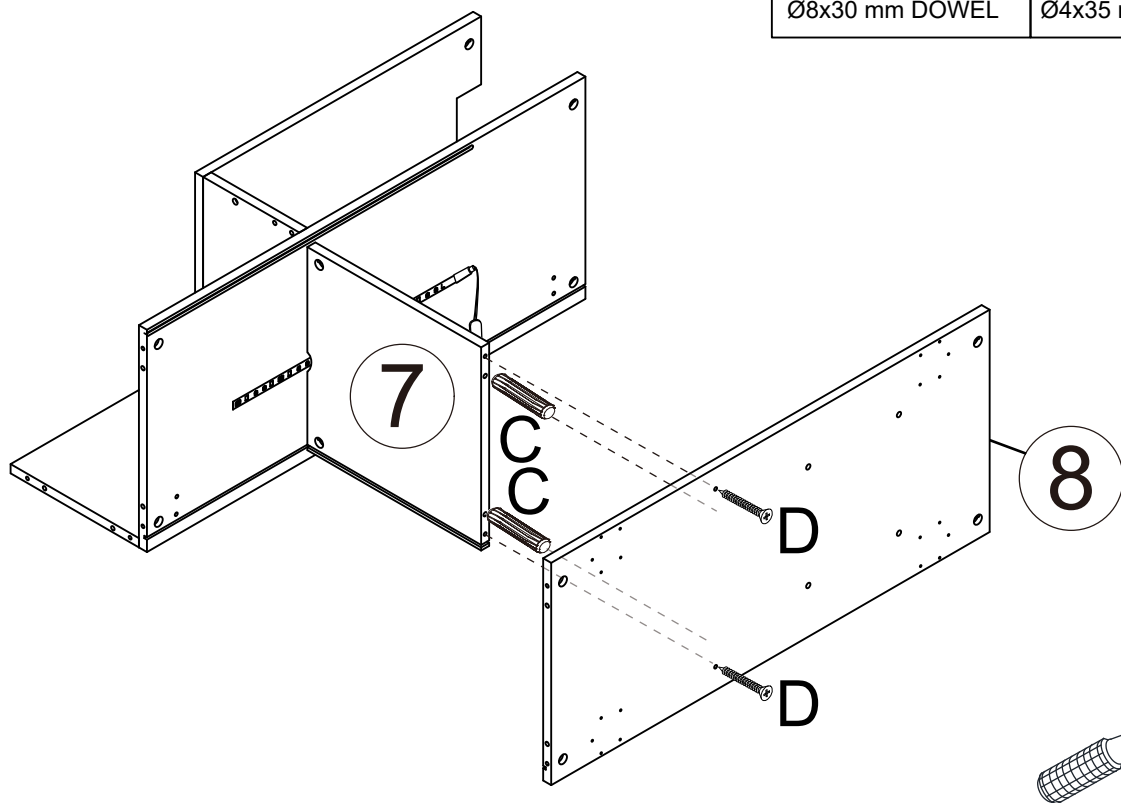

# Step 6



<p><b>C</b> x 2pcs</p>  <p>Ø8x30 mm DOWEL</p>	<p><b>D</b> x 2pcs</p>  <p>Ø4x35 mm SCREW</p>
--	--

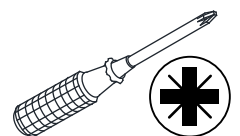

# Step 7

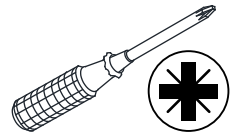
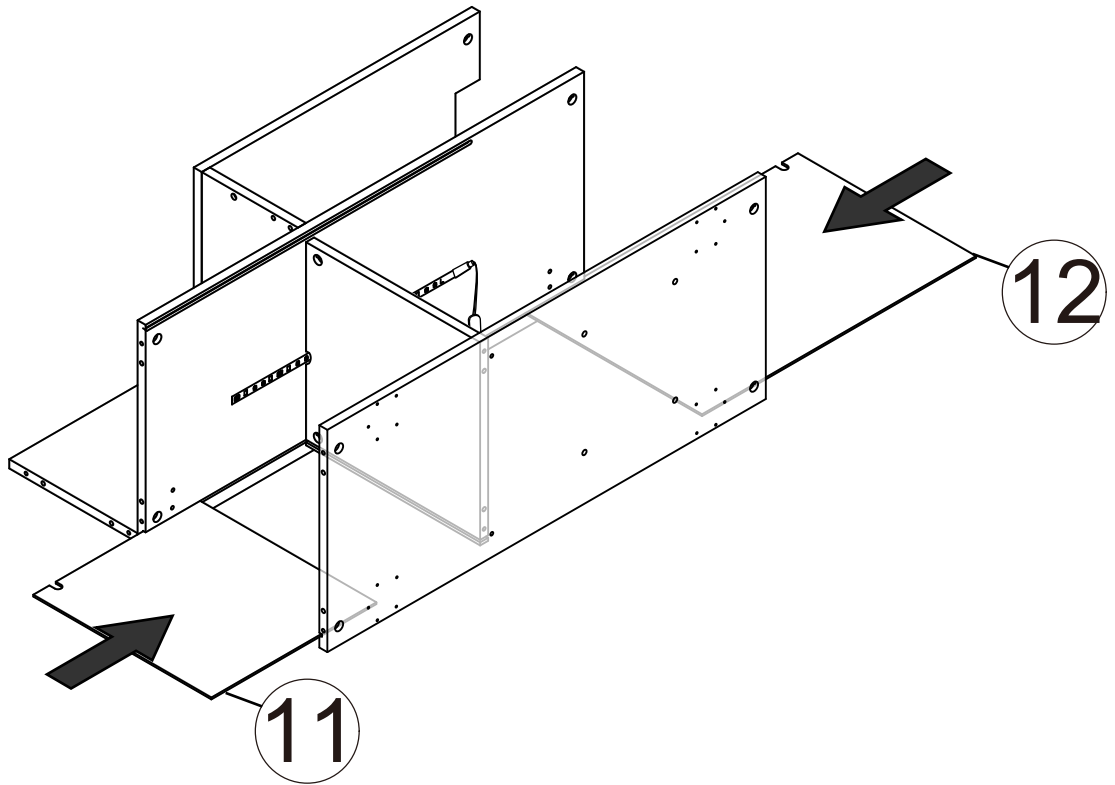

# Step 8

A x 14pcs

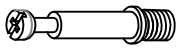

Ø6x35 mm  
CAM STUD

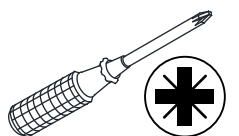
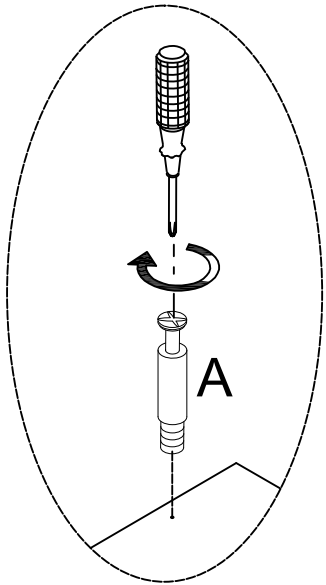
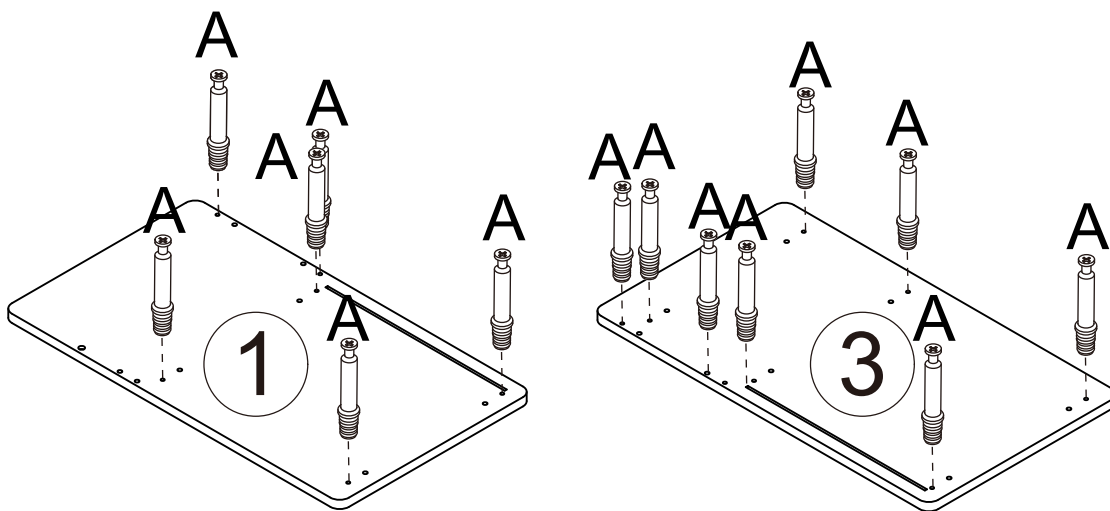

# Step 9



**K** x 6pcs

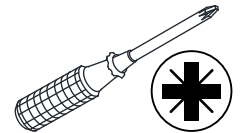
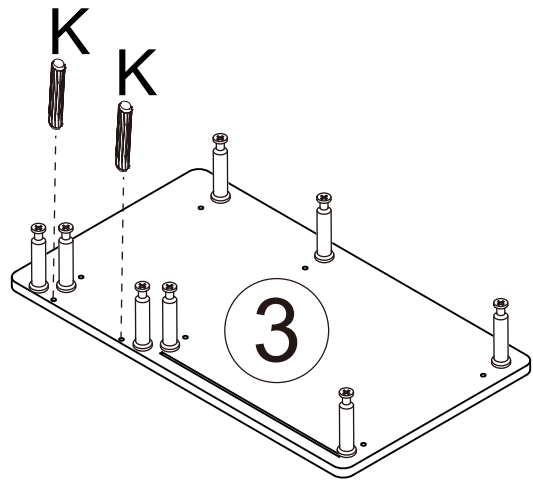
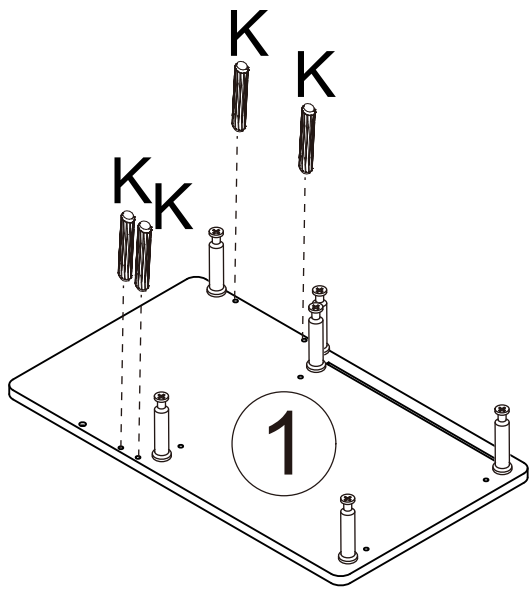

Ø6x30 mm DOWEL



# Step 10

<b>B</b> x 8pcs	<b>C</b> x 6pcs
	
Ø15x9 mm CAM LOCK	Ø8x30 mm DOWEL

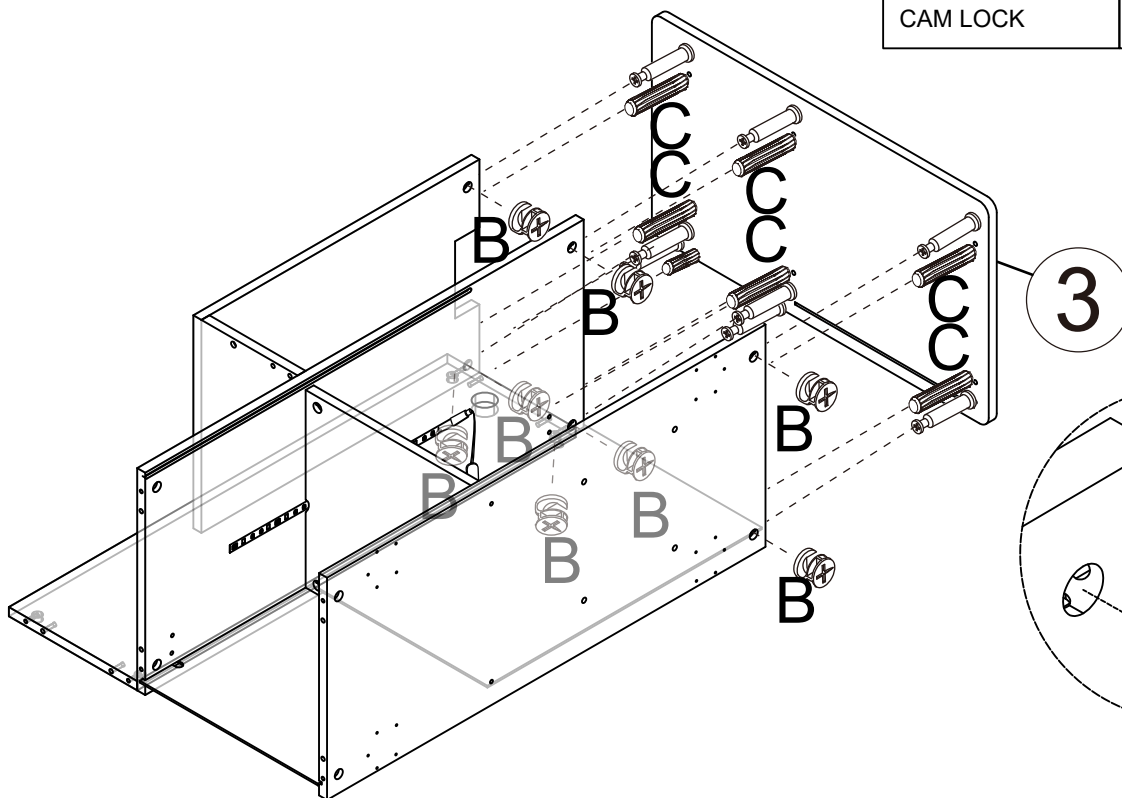

# Step 11

ⓔ x 4pcs



Ø5x25 mm SCREW

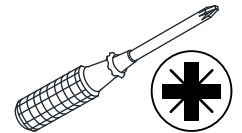
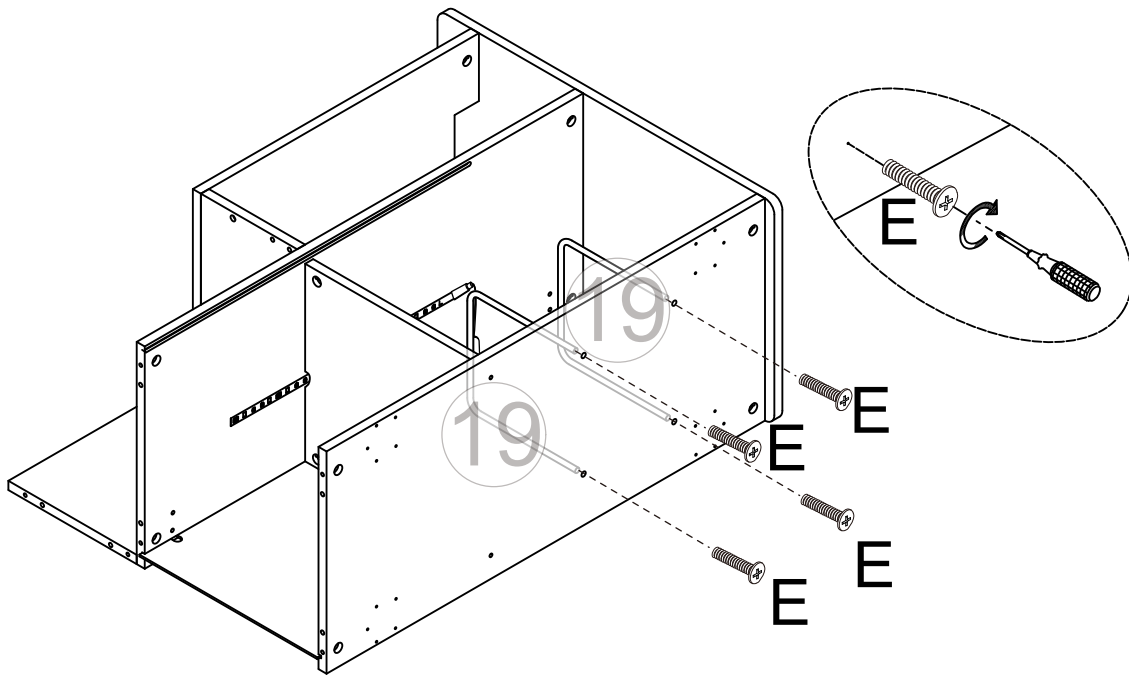

# Step 12

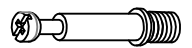

ⓐ x 6pcs

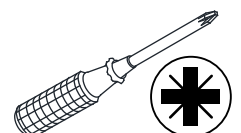
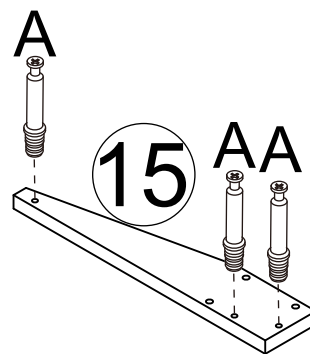
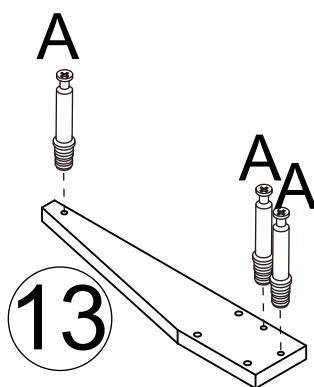
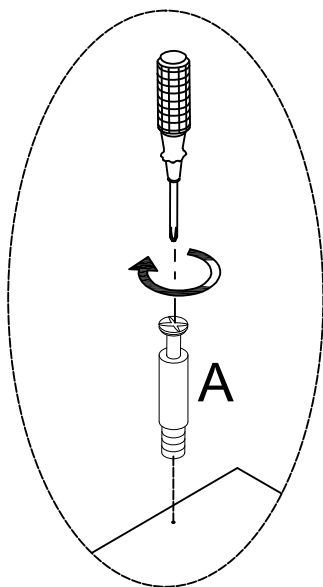

Ø6x35 mm  
CAM STUD



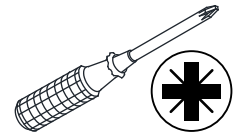
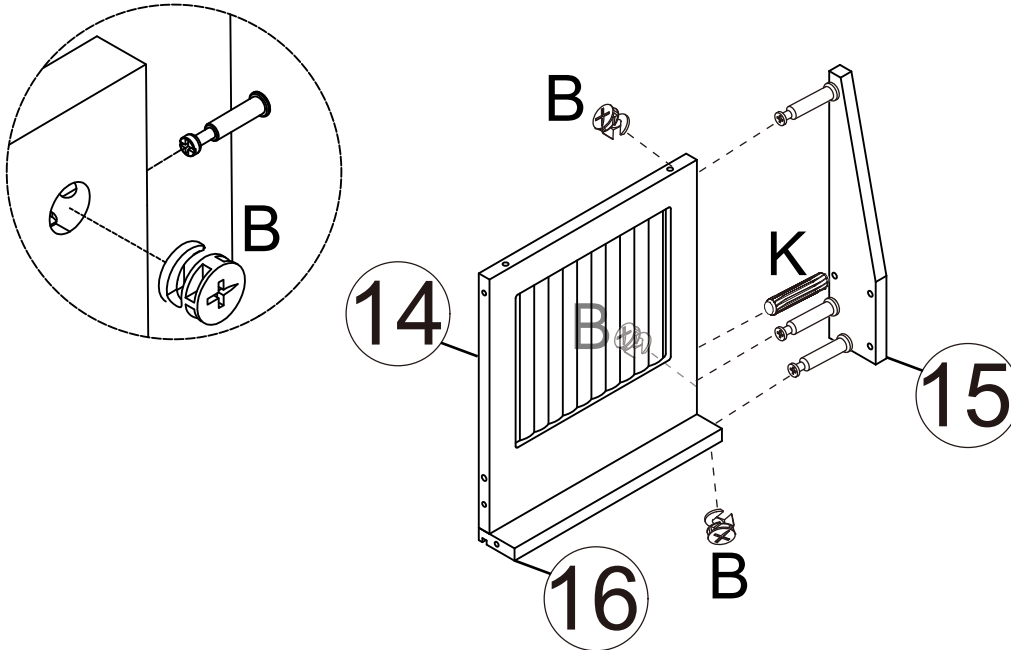

# Step 13

<b>B</b> x 3pcs  Ø15x9 mm CAM LOCK	<b>K</b> x 1pc  Ø6x30 mm DOWEL
--	---



# Step 14

<b>B</b> x 3pcs  Ø15x9 mm CAM LOCK	<b>K</b> x 5pcs  Ø6x30 mm DOWEL
--	--

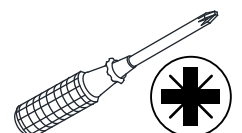
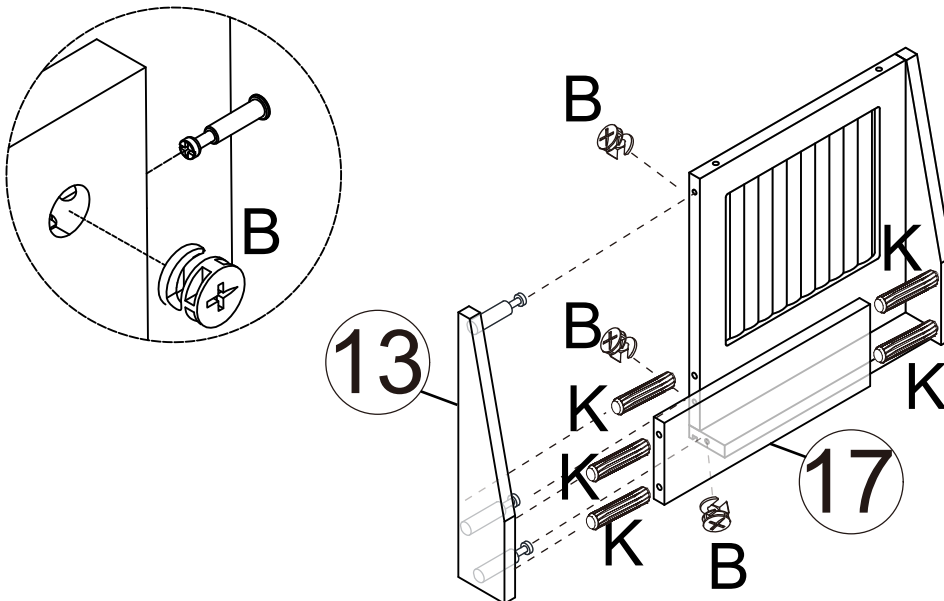

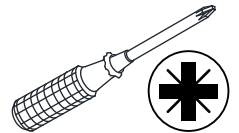
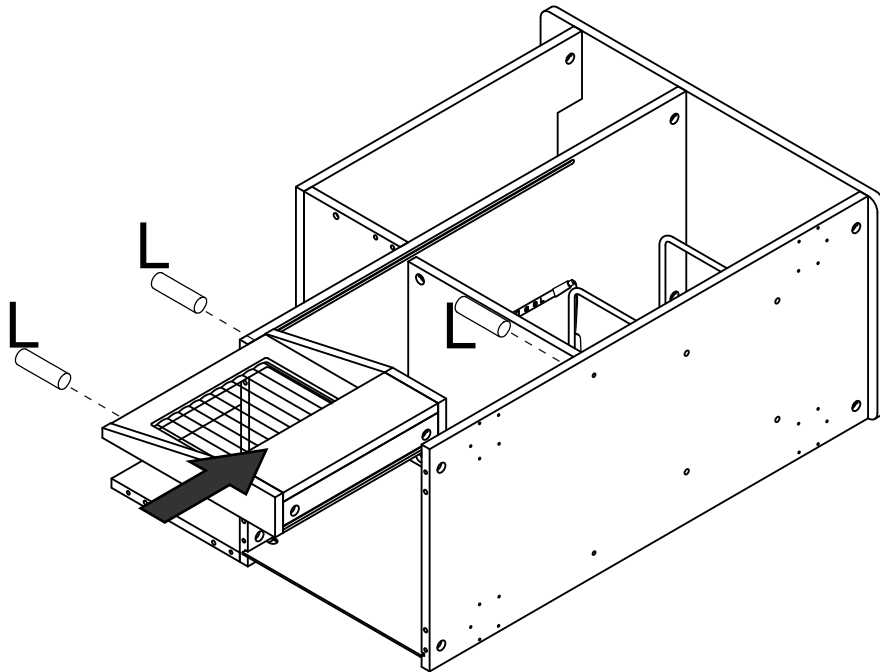

# Step 15

(L) x 3pcs  
  
 Ø5x12 mm  
 DOWEL PIN



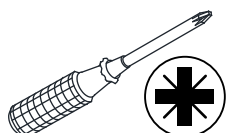
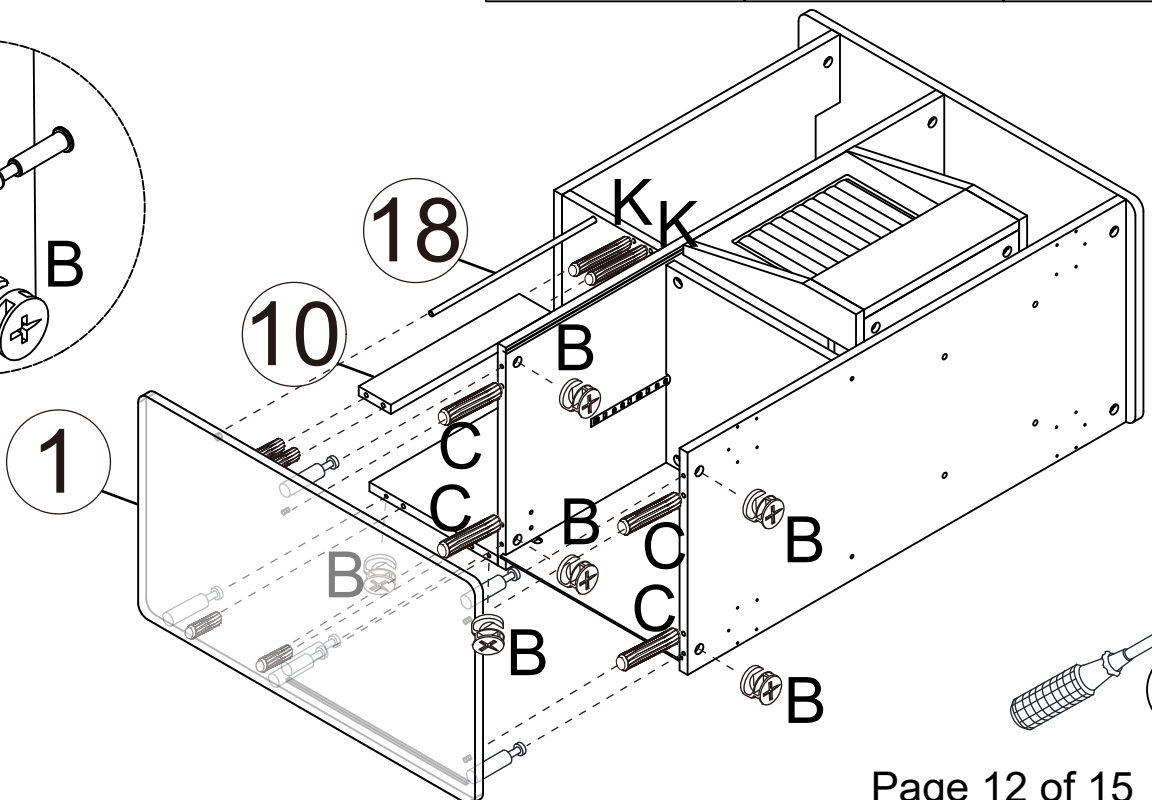
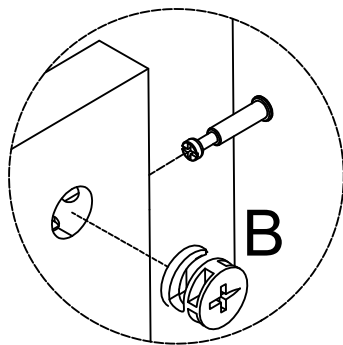

# Step 16

<p>(B) x 6pcs                    Ø15x9 mm                  CAM LOCK</p>	<p>(C) x 4pcs                    Ø8x30 mm DOWEL</p>	<p>(K) x 2pcs                    Ø6x30 mm DOWEL</p>
--	--	--



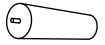

# Step 17

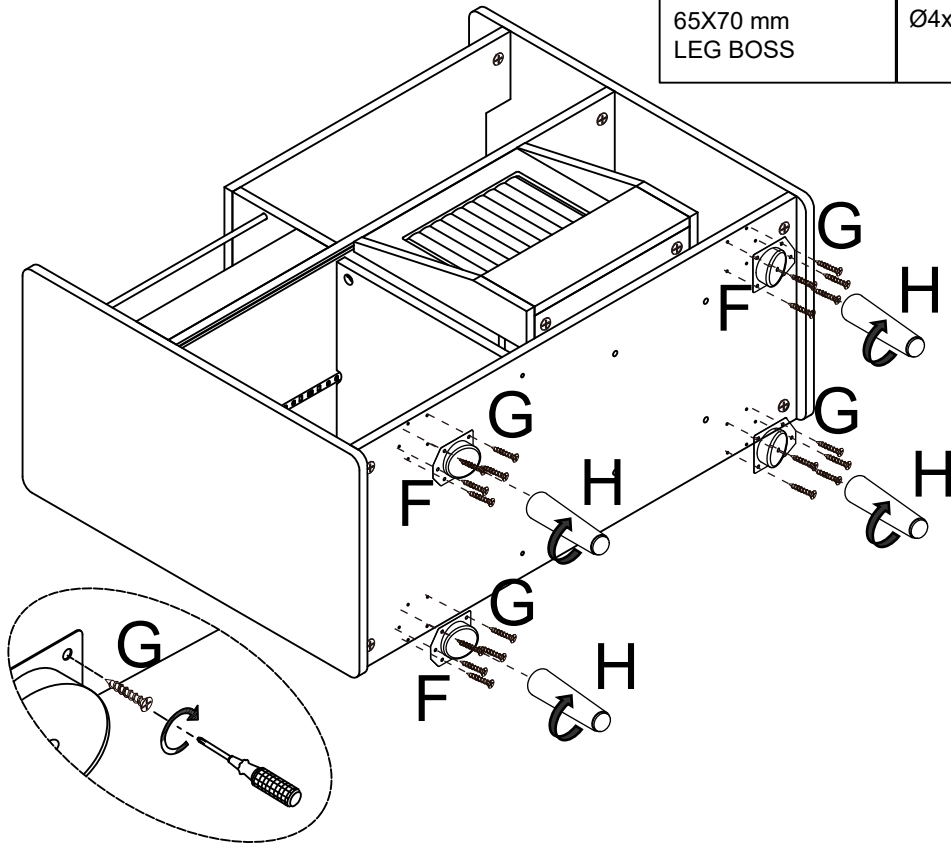
<b>F</b> x 4pcs  65X70 mm LEG BOSS	<b>G</b> x 20pcs  Ø4x14 mm SCREW	<b>H</b> x 4pcs  Ø35X175 mm SUPPORT LEG
--	---	---

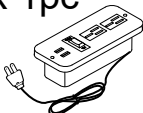

# Step 18

<b>I</b> x 1pc  POWER STRIP	<b>N</b> x 2pcs  Ø4x14 mm SCREW
--	--

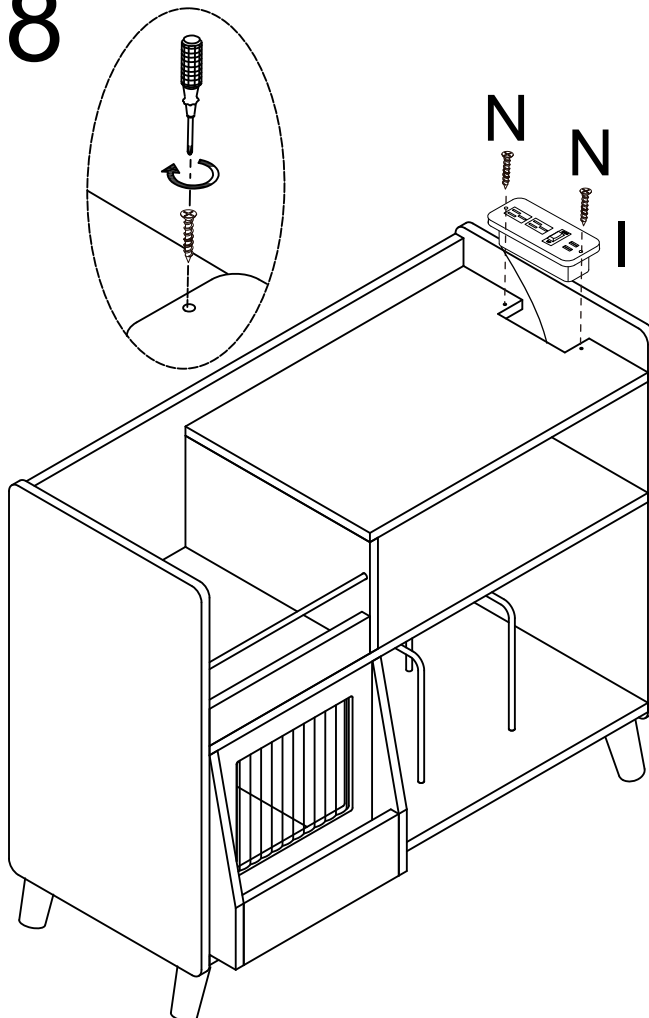

# Step 19

(M) x 2pcs  
  
WALL PLUGS

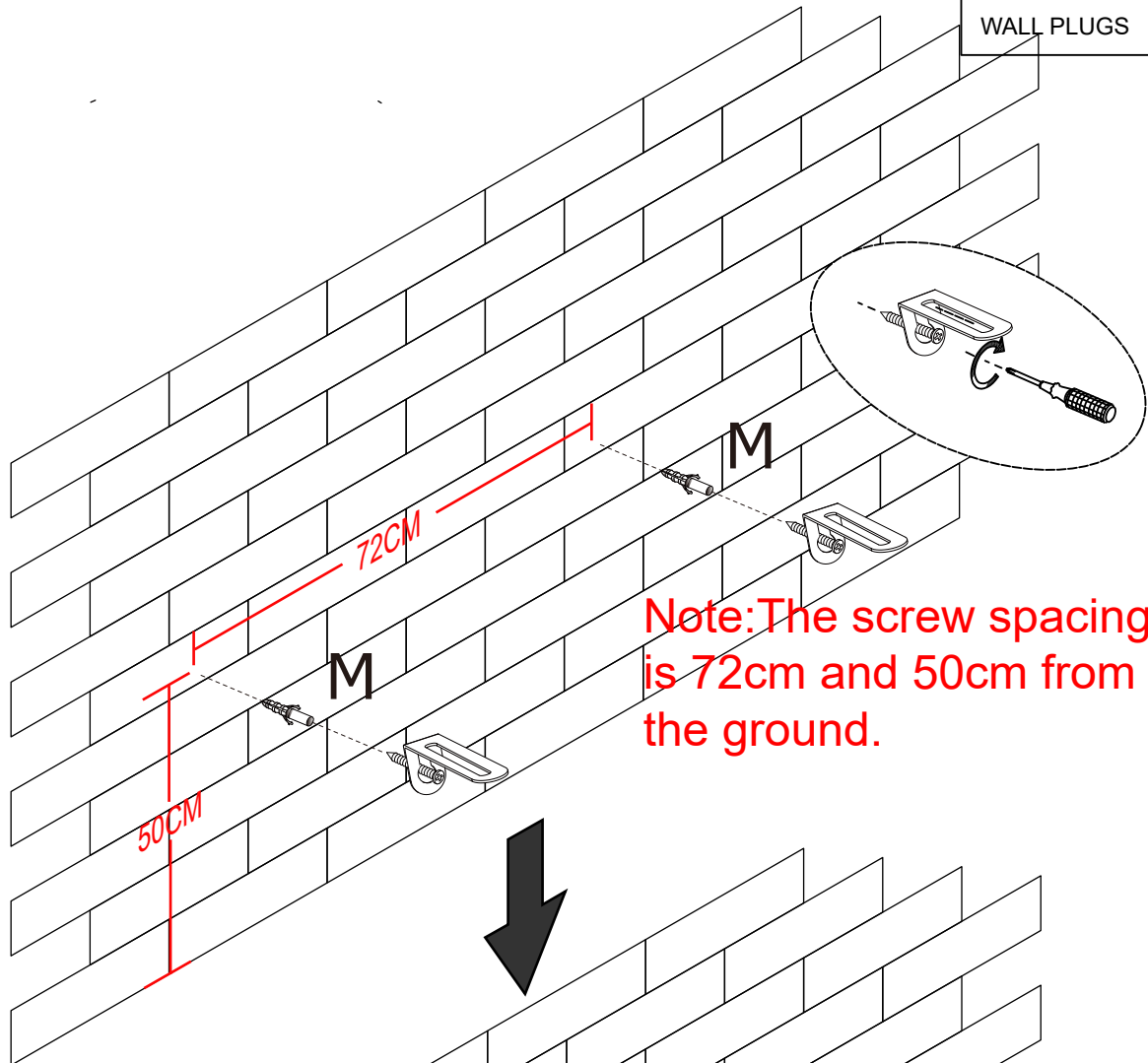

Note: The screw spacing is 72cm and 50cm from the ground.

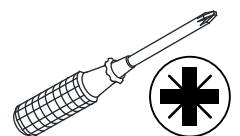
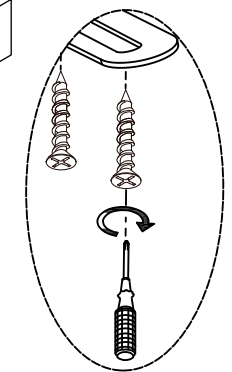
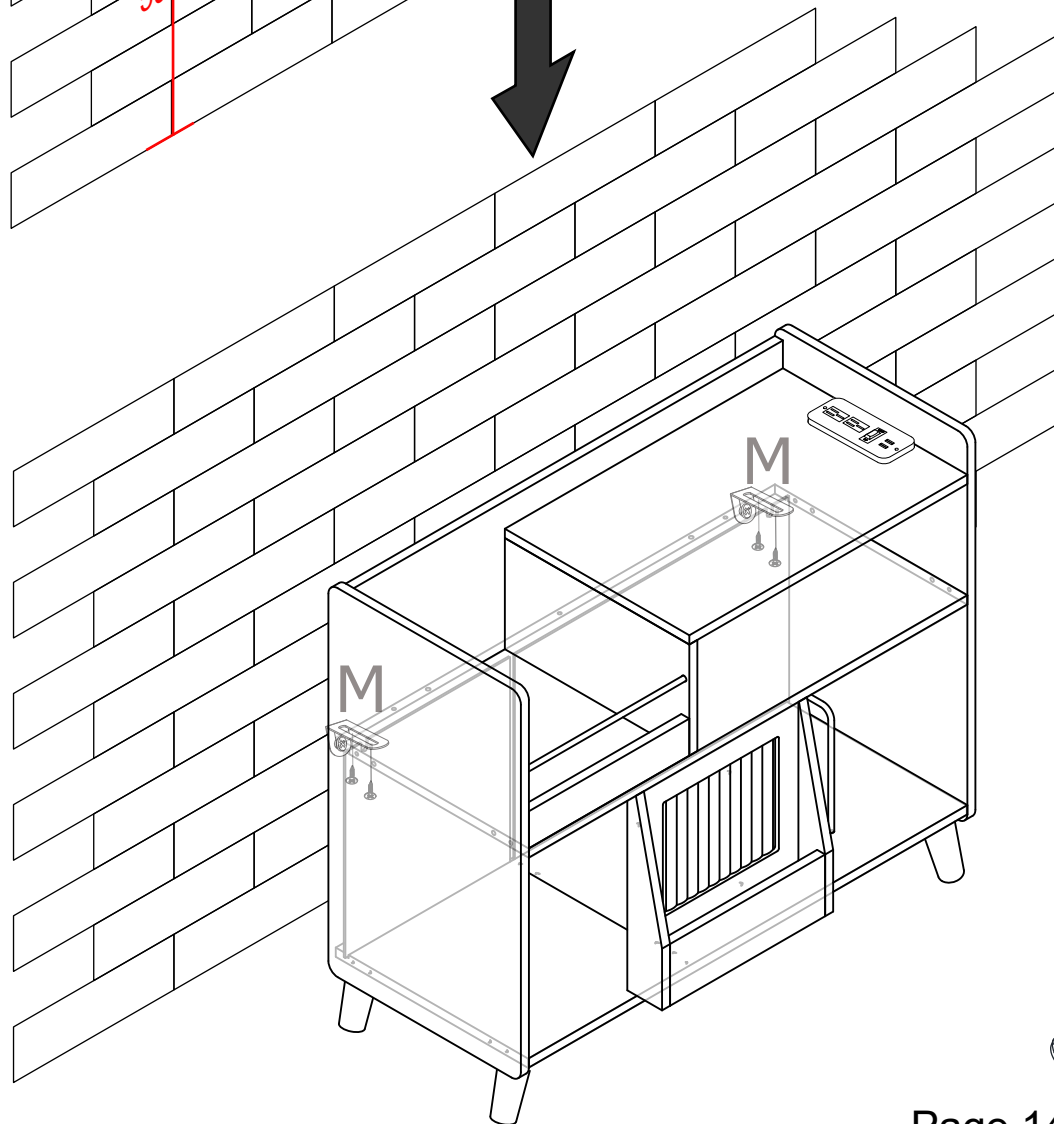

# Step 20

