

Coffee Table

Assembly Instructions - Please keep for future reference

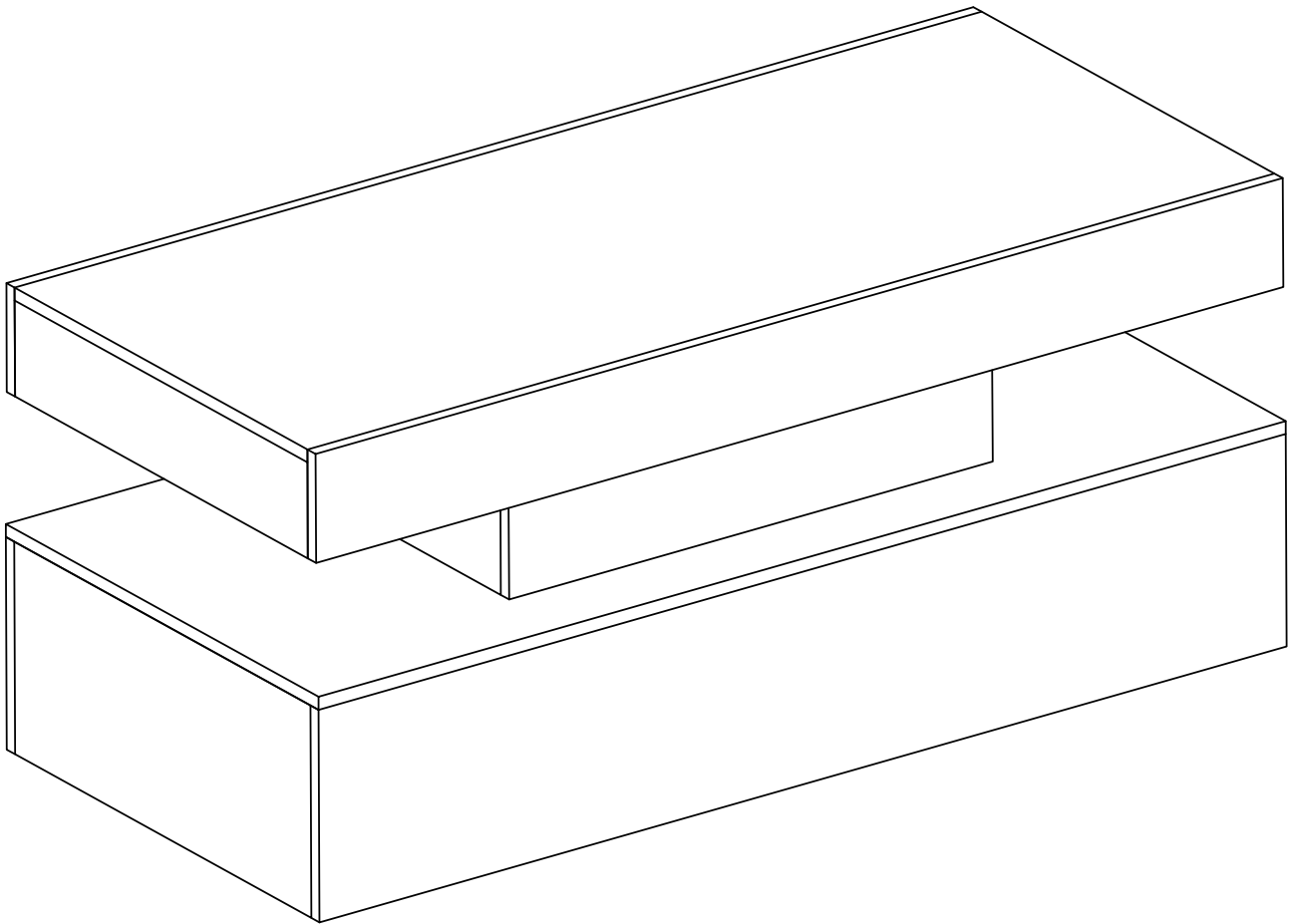

Dimensions

Width - 44 inch

Depth - 21 inch

Height - 6 inch

Important – Please read these instructions fully before starting assembly



Safety and Care Advice

Important – Please read these instructions fully before starting assembly

- Check you have all the components and tools listed on the following pages.
- Remove all fittings from the plastic bags and separate them into their groups.
- Keep children and animals away from the work area, small parts could choke if swallowed.
- Make sure you have enough space to layout the parts before starting.

- During assembly do not stand or put weight on the product, this could cause damage.
- Assemble the item as close to its final position (in the same room) as possible.
- Assemble on a soft level surface to avoid damaging the unit or your floor.
- Parts of the assembly will be easier with 2 people.



- To reduce the likelihood of damaging your product please ensure that your power drill is set on a low torque setting.

Care and maintenance

- Only clean using a damp cloth and mild detergent, do not use bleach or abrasive cleaners.
- From time to time check that there are no loose screws on this unit.
- This product should not be discarded with household waste. Take to your local authority waste disposal centre.

Handy Hints

- Assemble all parts and bolts loosely during assembly, only once the product is complete should you fully tighten the bolts
- Regularly check and ensure that all bolts and fittings are tightened properly.

WARNING

In order to help prevent overturning – please follow these instructions

To help prevent product toppling over please follow the below steps:-

Use the anti tip strap or wall fixing method provided (if applicable)
Do not allow children to climb or hang on the furniture
Do not open more than one drawer at a time
Do not place heavy items in the top drawers
Do not place heavy items on top of the furniture, unless the furniture has been designed for this purpose

Please note that only the anti tip strap is provided.
You will need to provide wall plugs and screws applicable for your wall type

Components - Panels

Please check you have all the panels listed below

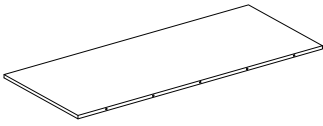

1 (100X42.6X1.2) X1

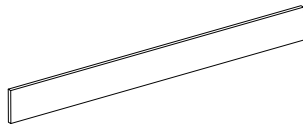

2 (100X10X1.2) X2

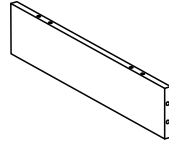

3 (42.6X8.8X1.2) X2

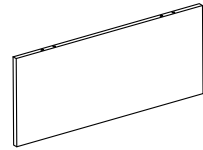

4 (50X21X1.2) X2

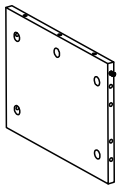

5 (28.2X21X1.2) X2

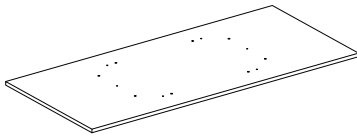

6 (100X45.5X1.2) X1

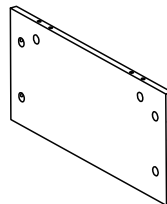

7 (43X19.5X1.2) X2

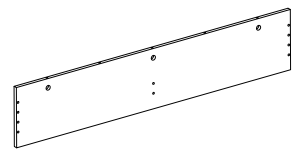

8 (100X19.5X1.2) X2

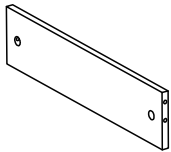







9 (43X10X1.2) X1

Components - Fittings

Please check you have all the fittings listed below

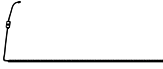
Note: The quantities below are the correct amount to complete the assembly. In some cases more fittings may be supplied than are required.

A  7*35mm Cam Bolt x 48	B  Camlock x 48	C  6*30mm Wooden Dowel x 54
D  Plastic buckle x 8	E  5*40mm Screw x 6	F  Strip light x 1
G  3.5*10mm Screw x 8		

Tools required



Phillips screwdriver
(medium & large)

Ruler - Use this ruler to help correctly identify the screws

0 5 10 15 20 25 30 35 40 45 50 55 60 65 70 75 80 85 90 95 100 105 110 115 120 125 130 135 140 145 150 155 160 165 170

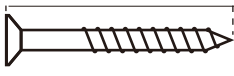

The screws length is measured from the head to the point (30mm screw shown).

Using Camlocks

Step 1

Connect the male camlock as directed in the assembly instructions using a screwdriver.

1

DO NOT OVER TIGHTEN.
NE PAS SERRER EXCESSIVEMENT.

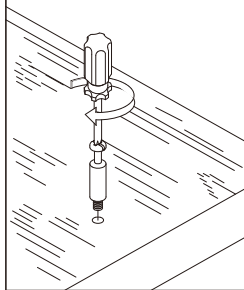

Step 2

Push the male camlock into the entry hole.

2

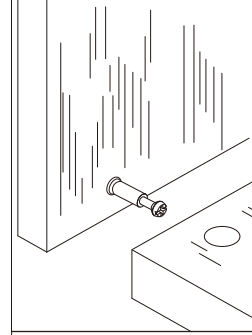

Step 3

Insert the female camlock as shown in the instructions.

Note: ensure that the arrow on the top of the camlock points towards the entry hole for the male camlock.

3

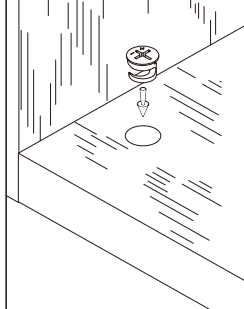

Step 4

Turn the female camlock clockwise with a screwdriver.

You should feel a click when the camlock is locked in place.

The joint is now secure.

4

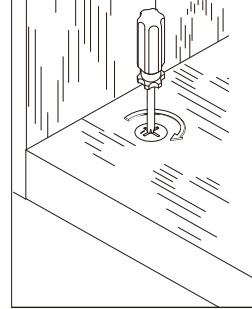

Assembly Instructions

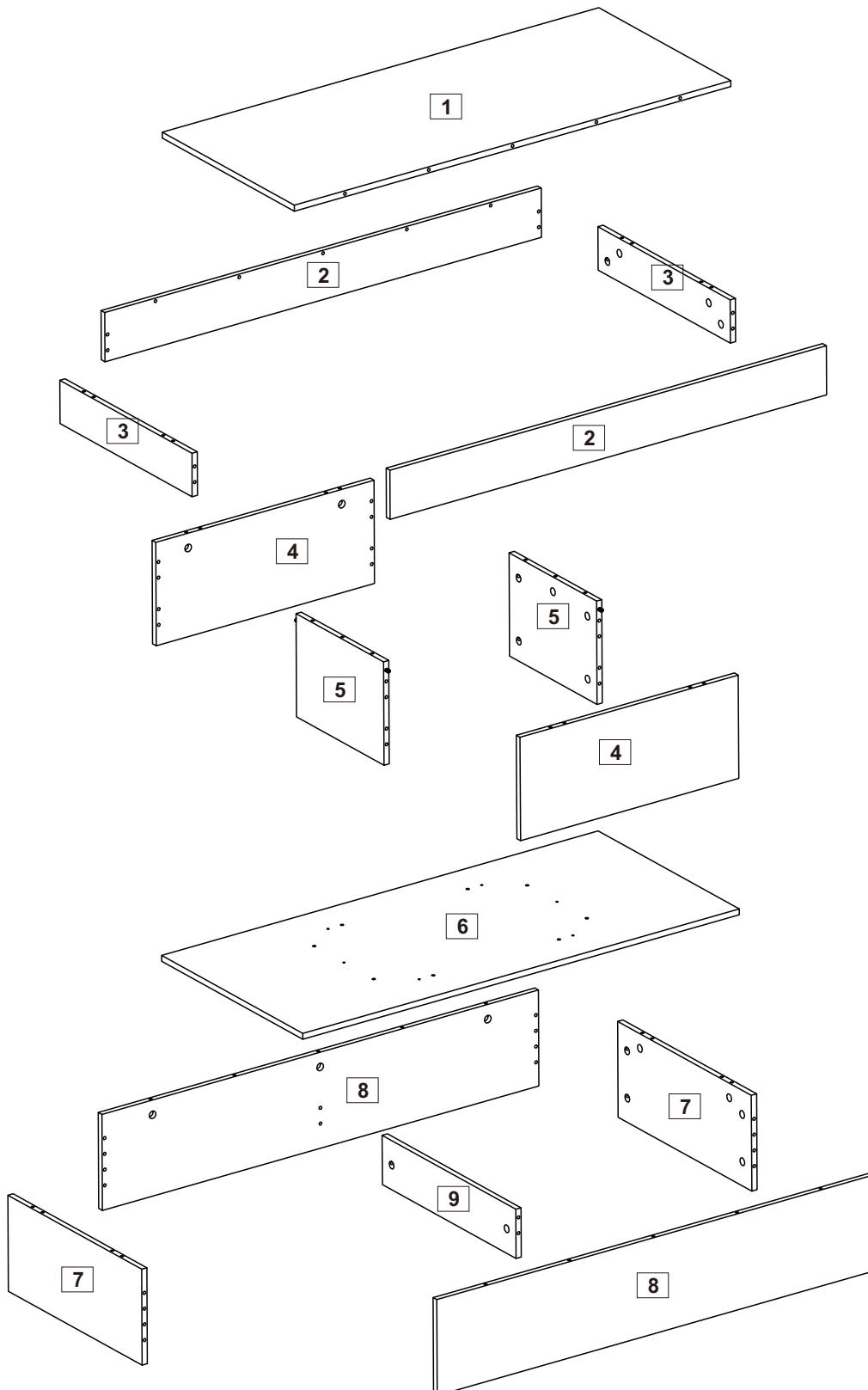

Assembly Instructions

Step 1

CAM-LOCK

Tighten until shoulder is flush with panel. Do not overtighten or undertighten (see example below)

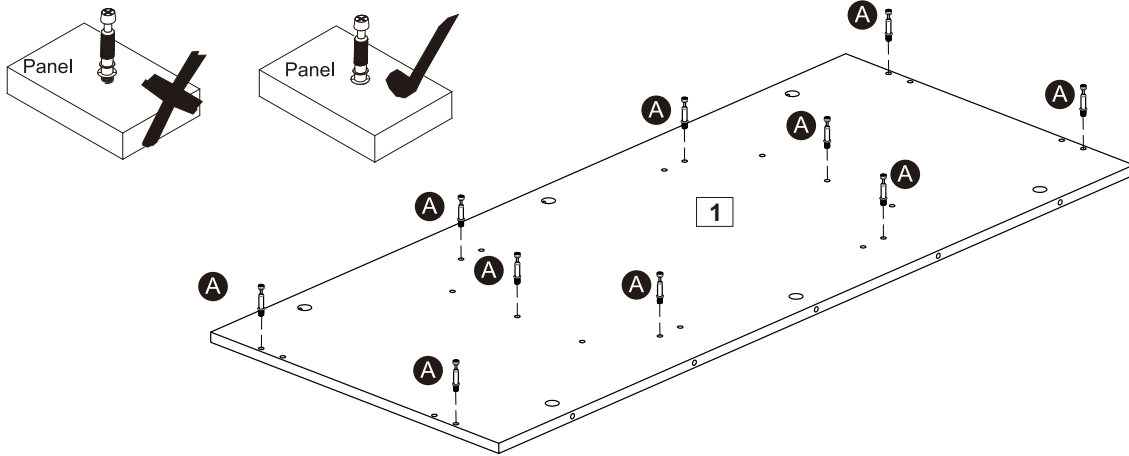
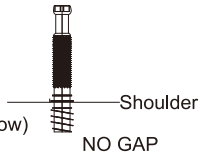

Secure the cam pin (A) to the part (1) with a screwdriver.

Step 2

CAM-LOCK

Tighten until shoulder is flush with panel. Do not overtighten or undertighten (see example below)

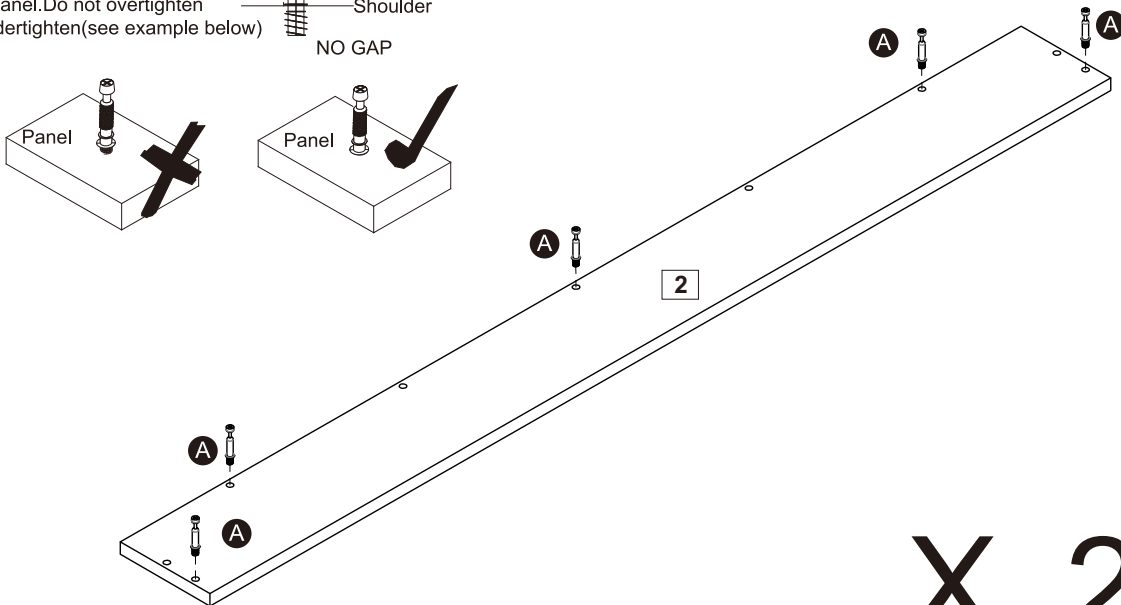
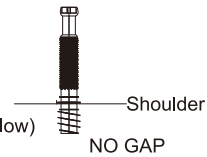

Secure the cam pin (A) to the part (2) with a screwdriver.

Assembly Instructions

Step 3

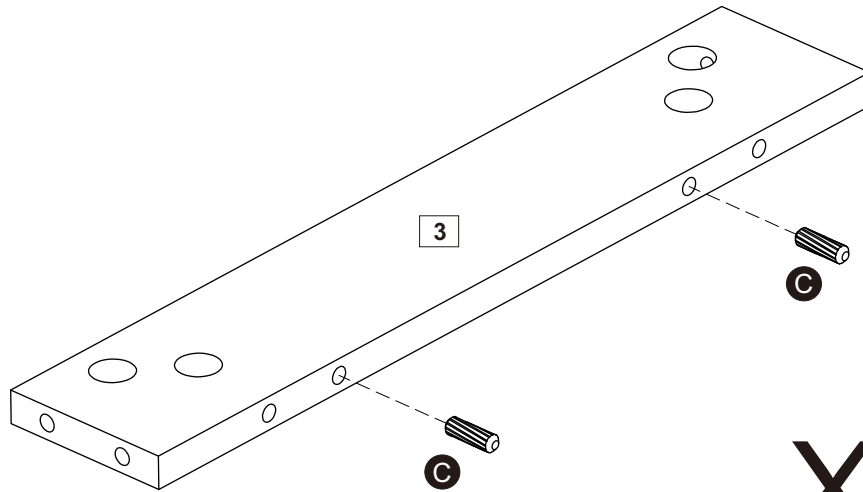

X 2

Insert wooden dowel (C) into part (3)

Step 4

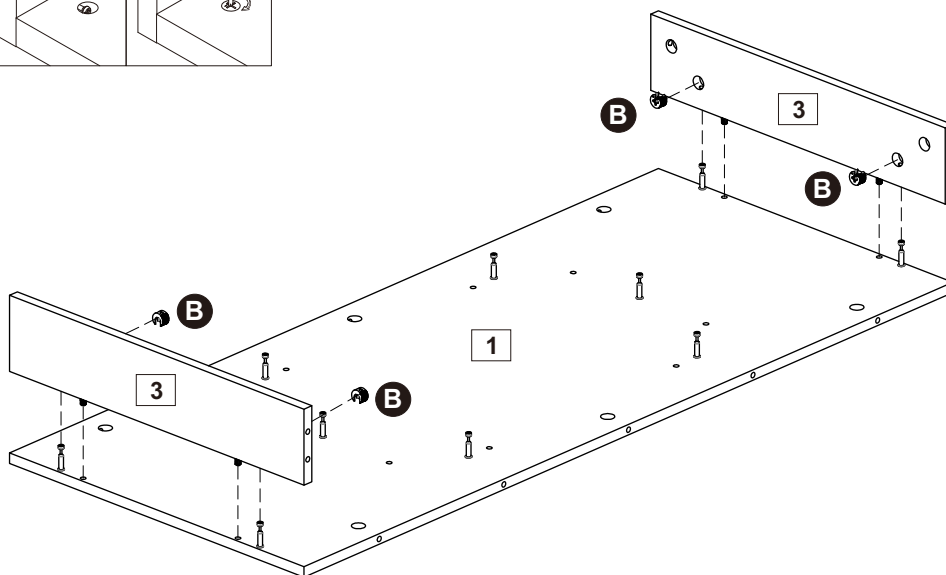
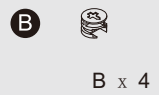
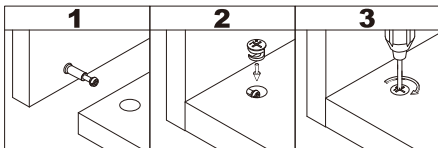

Connect the top plate (1) to the cowl panel (3), insert and lock the cam lock (B).

Assembly Instructions

Step 5



C x 8

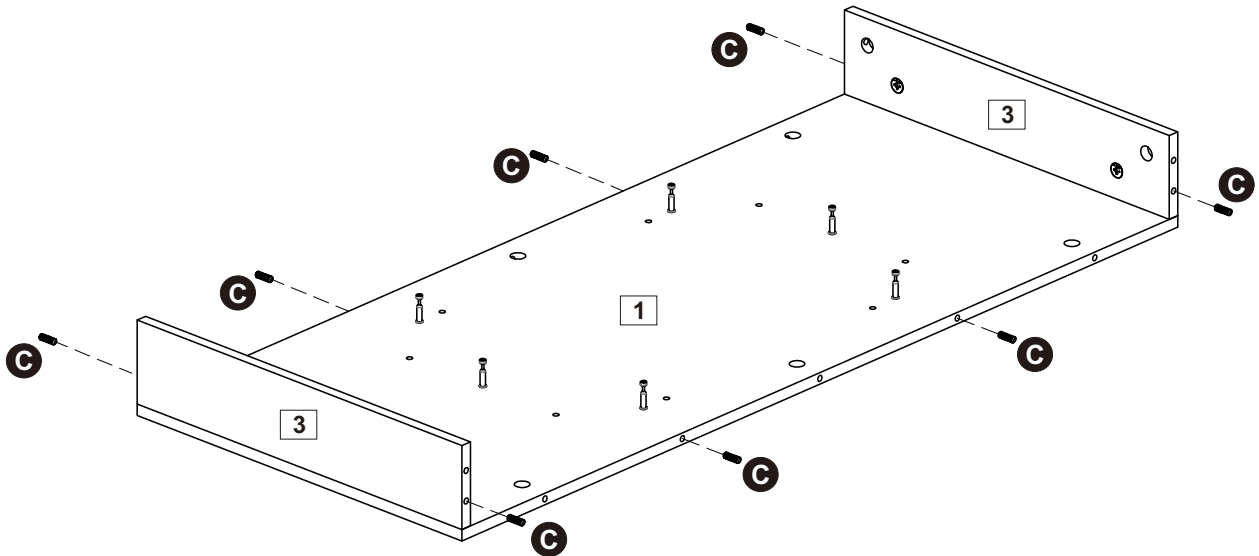

Insert wooden dowel (C) into part (1,3)

Step 6

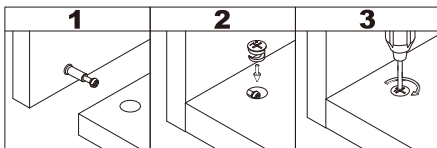

B x 10

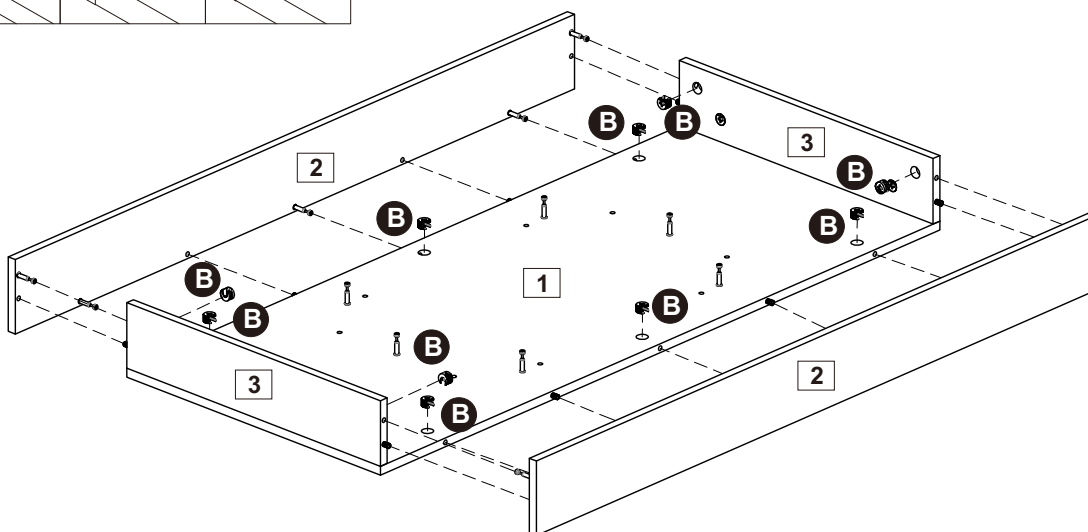

Connect components (2) to components (1, 3), insert and lock cam lock (B).

Assembly Instructions

Step 7

CAM-LOCK

Tighten until shoulder is flush with panel. Do not overtighten or undertighten (see example below)

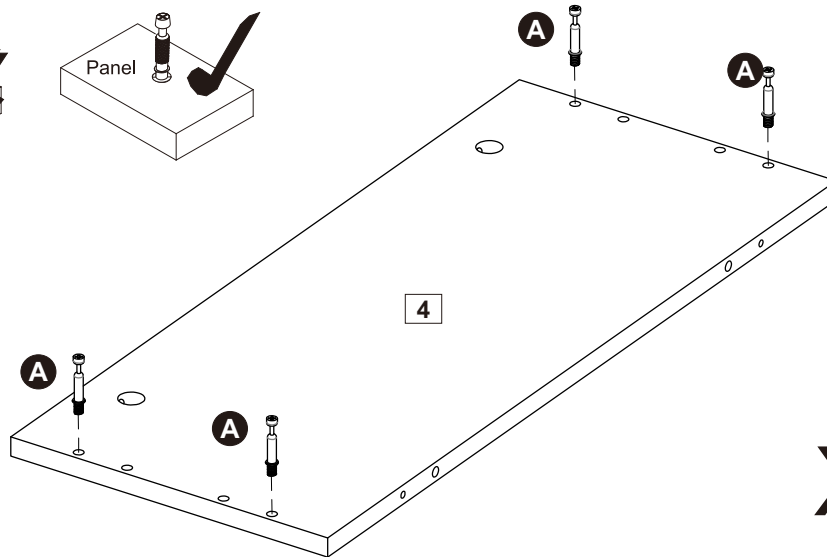
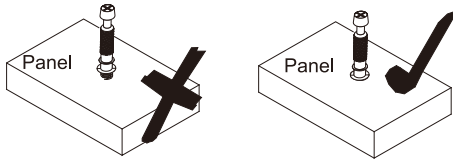
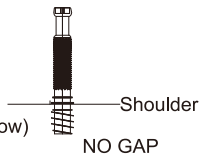

A X 8

X2

Secure the cam pin (A) to the part (4) with a screwdriver.

Step 8

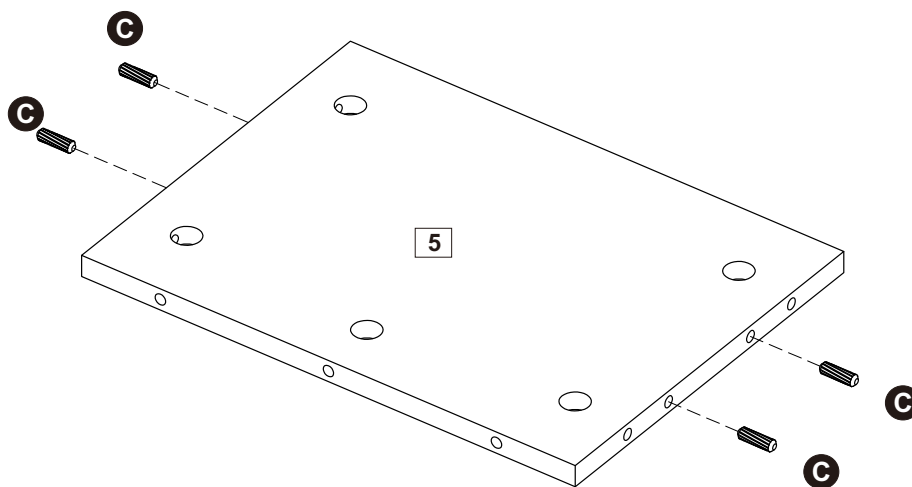

C x 8

X2

Insert wooden dowel (C) into part (5)

Assembly Instructions

Step 9

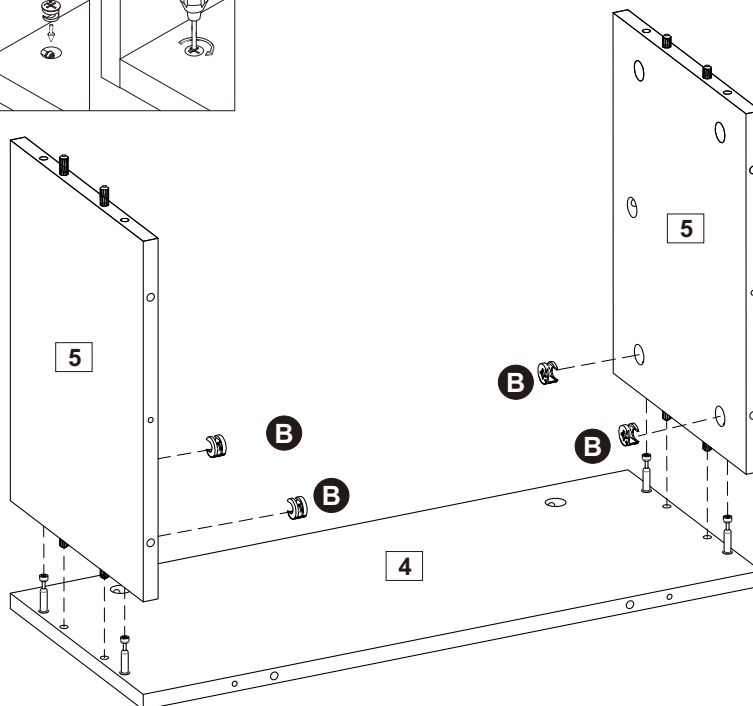
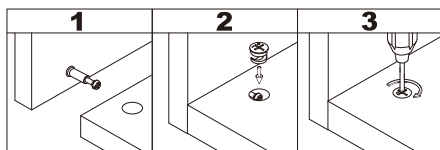

B 
B x 4

Connect components (4) to components (5), insert and lock cam lock (B).

Step 10

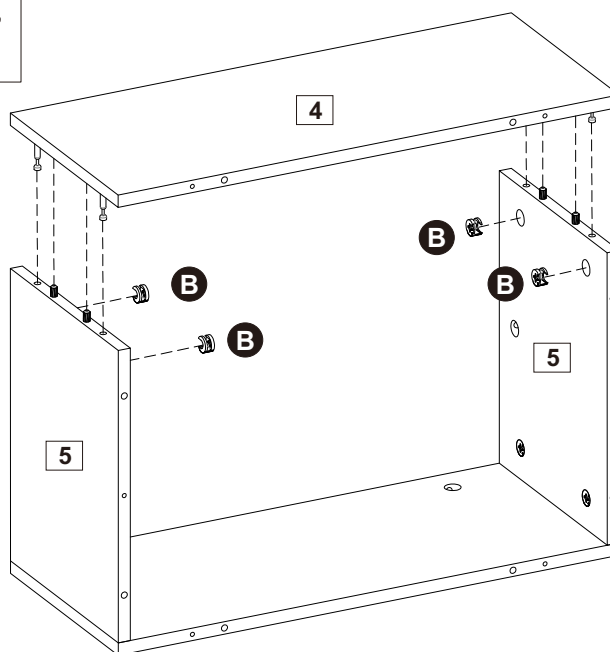
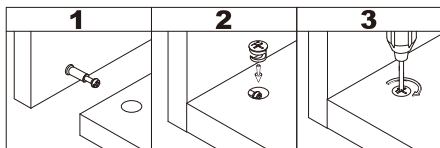

B 
B x 4

Connect components (4) to components (5), insert and lock cam lock (B).

Assembly Instructions

Step 11

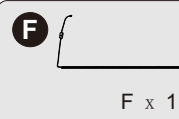
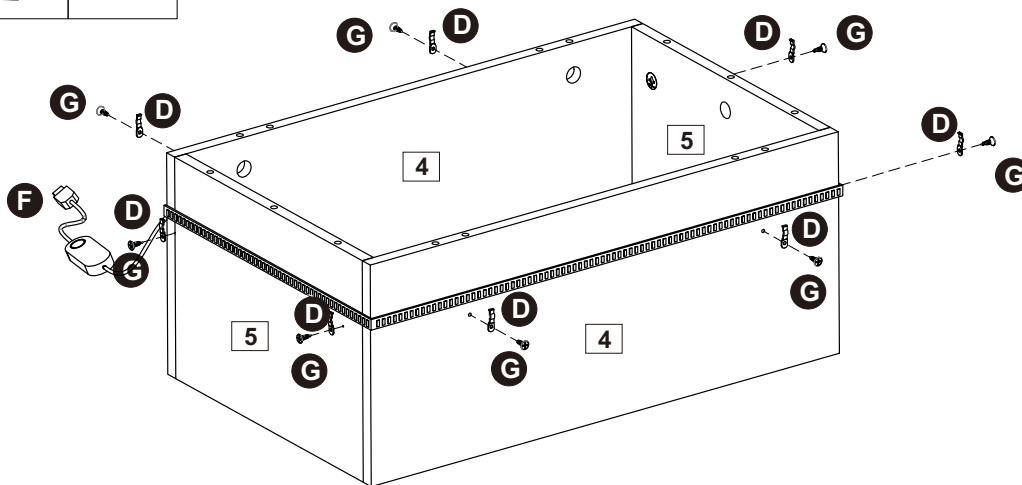
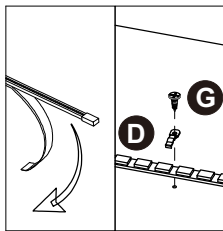

As shown in the figure, the parts (D, G) for the lamp belt (F), secure to (4,5).

Step 12

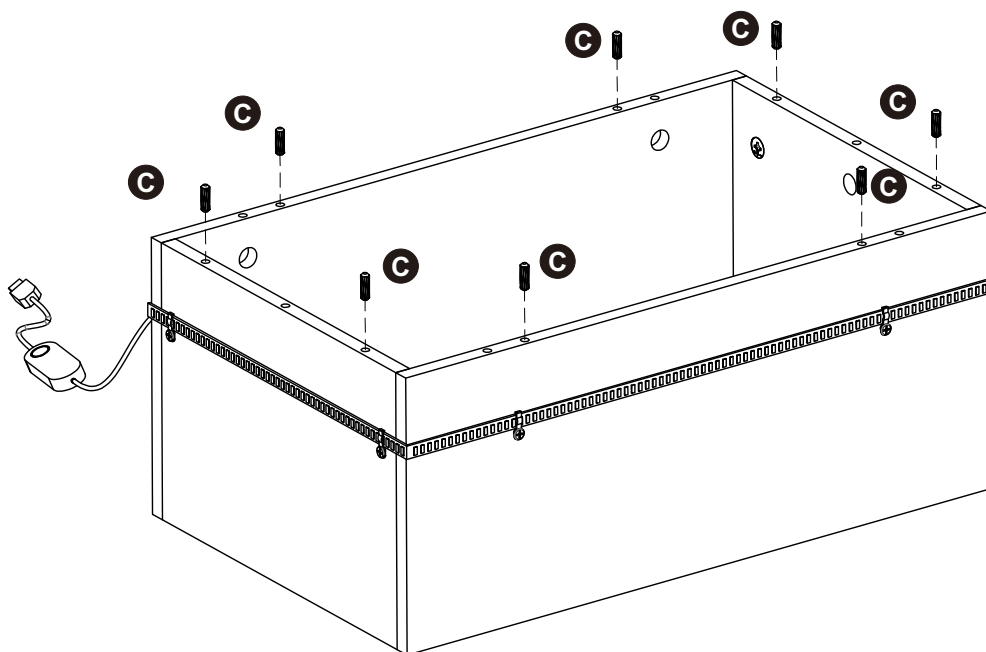

Insert wooden dowel (C) into part (4,5)

Assembly Instructions

Step 13

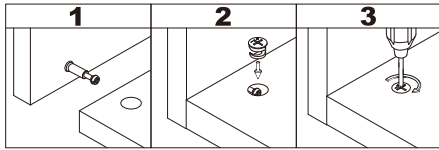

B 
B x 6

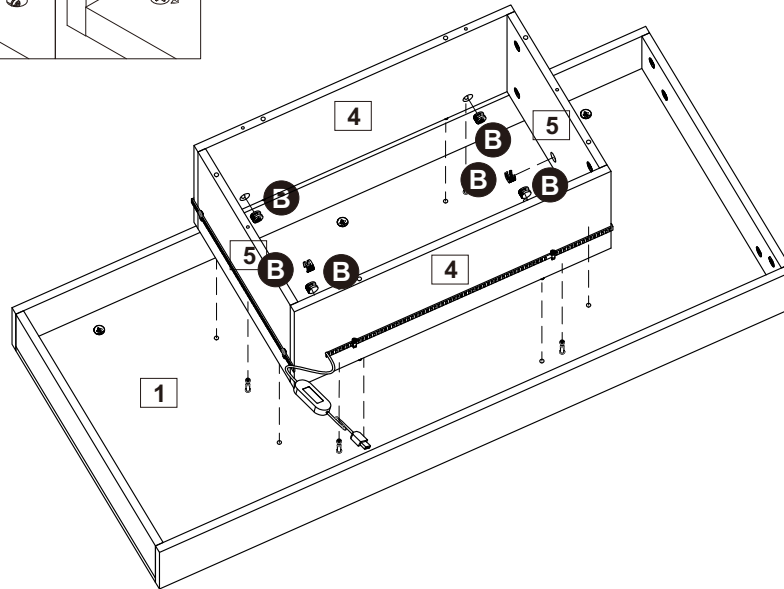

Connect components (4,5) to components (1), insert and lock cam lock (B).

Step 14

C 
C x 8

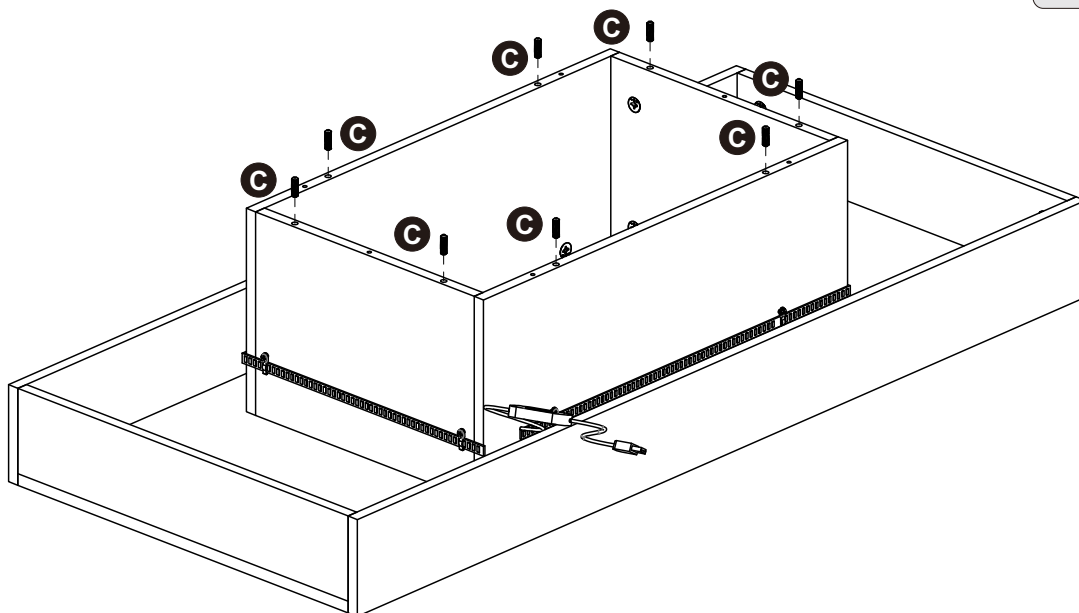

Insert wooden dowel (C) into part (4,5)

Assembly Instructions

Step 15

E 
E x 6

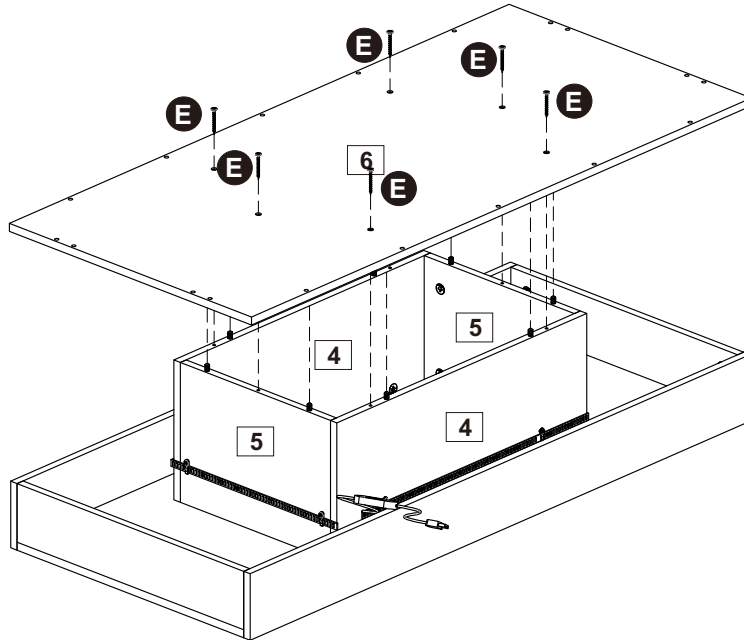

Secure component (6) with screw (E) using a screwdriver.

Step 16

A 
A X 10

CAM-LOCK

Tighten until shoulder is flush with panel. Do not overtighten or undertighten (see example below)

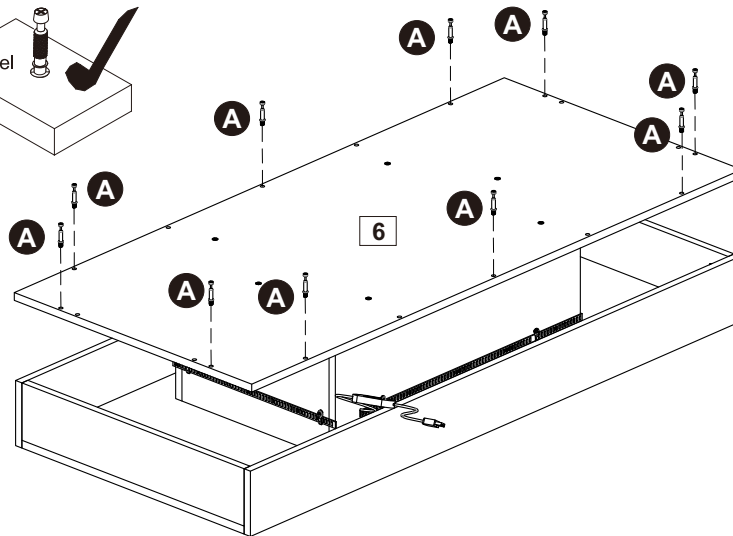
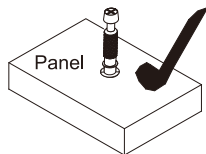
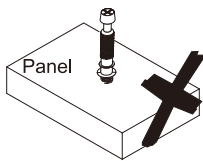
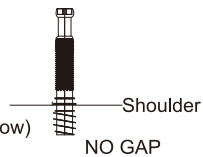

Secure the cam pin (A) to the part (6) with a screwdriver.

Assembly Instructions

Step 17



CAM-LOCK

Tighten until shoulder is flush with panel. Do not overtighten or undertighten (see example below)

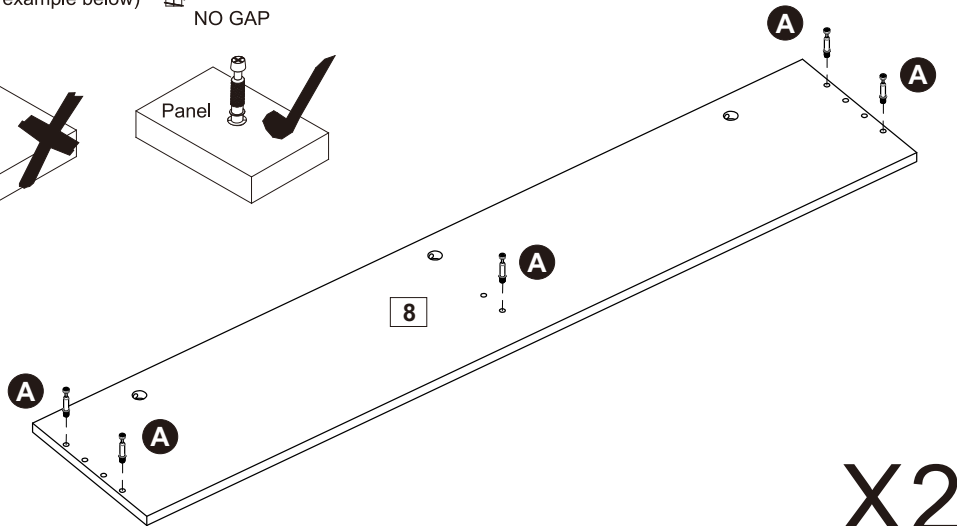
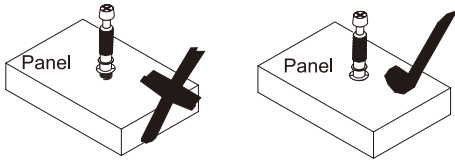
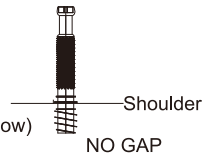

X2

Secure the cam pin (A) to the part (8) with a screwdriver.

Step 18

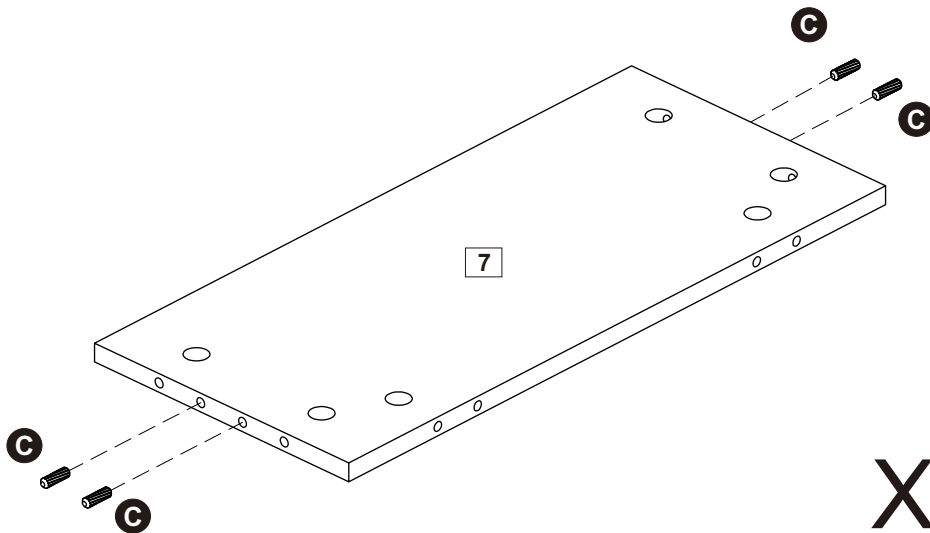

X2

Insert wooden dowel (C) into part (7)

Assembly Instructions

Step 19

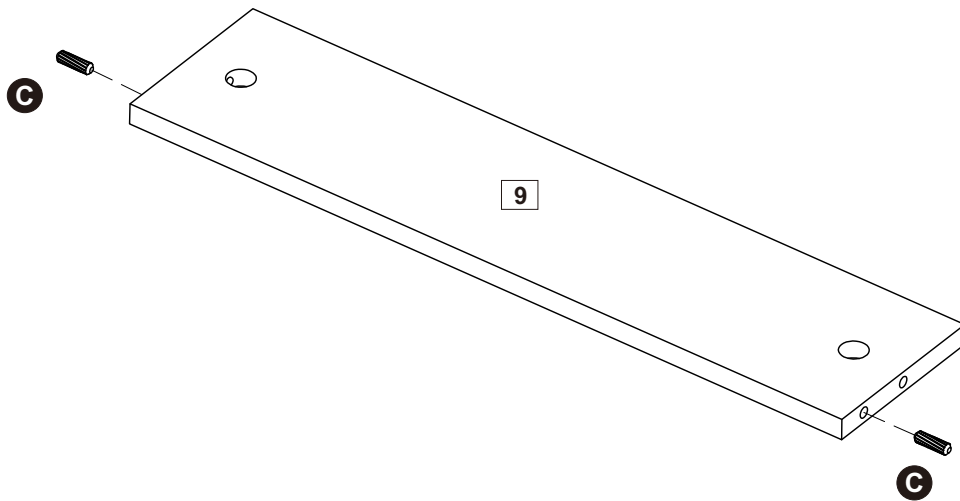

Insert wooden dowel (C) into part (9)

Step 20

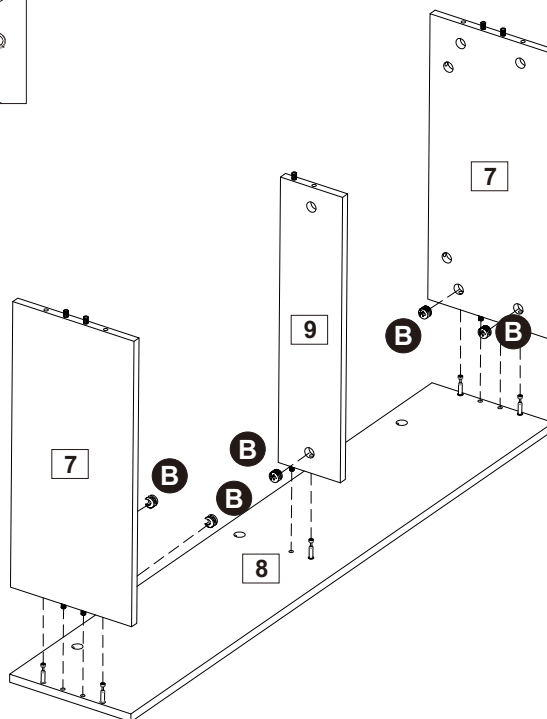
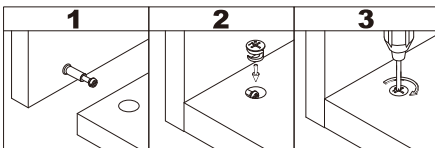

Connect components (7.9) to components (8), insert and lock cam lock (B).

Assembly Instructions

Step 21

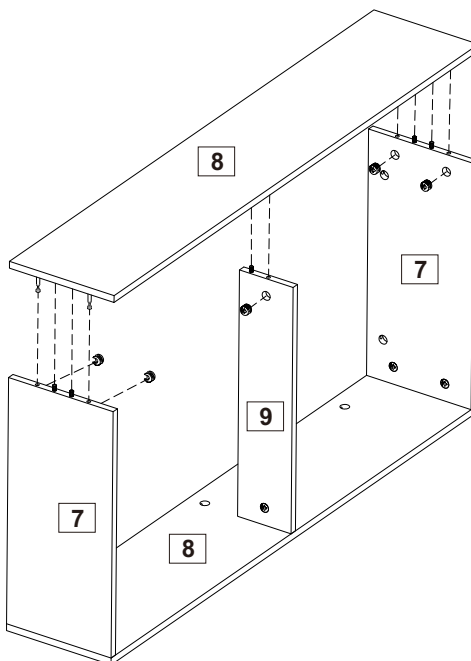
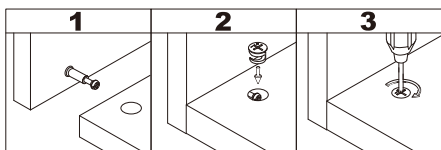

B



B x 5

Connect components (7,9) to components (8), insert and lock cam lock (B).

Step 22

C



C x 8

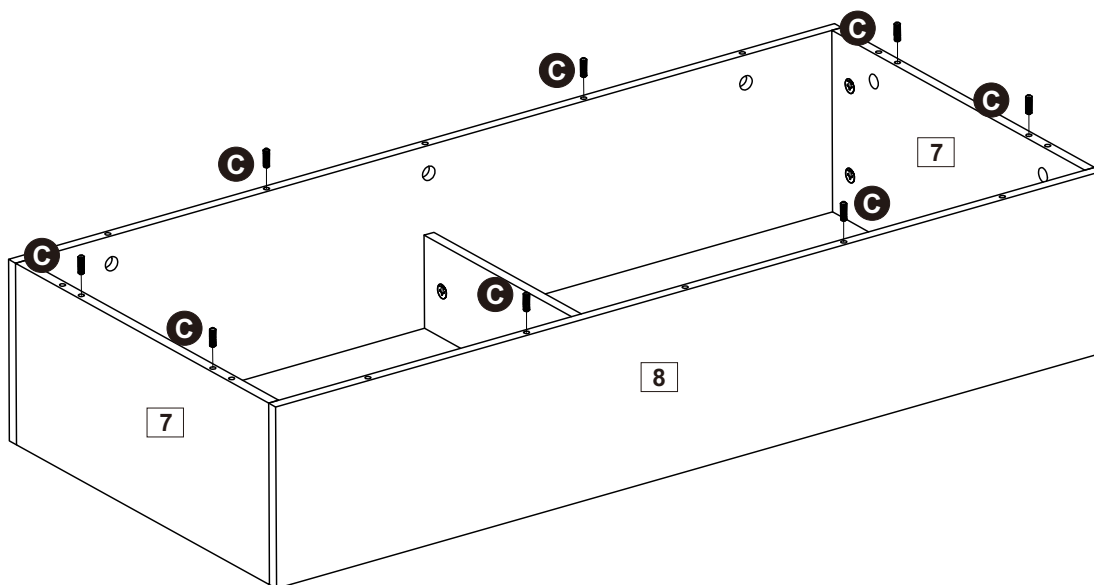

Insert wooden dowel (C) into part (7,8)

Assembly Instructions

Step 23

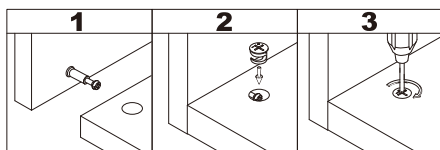

B



B x 10

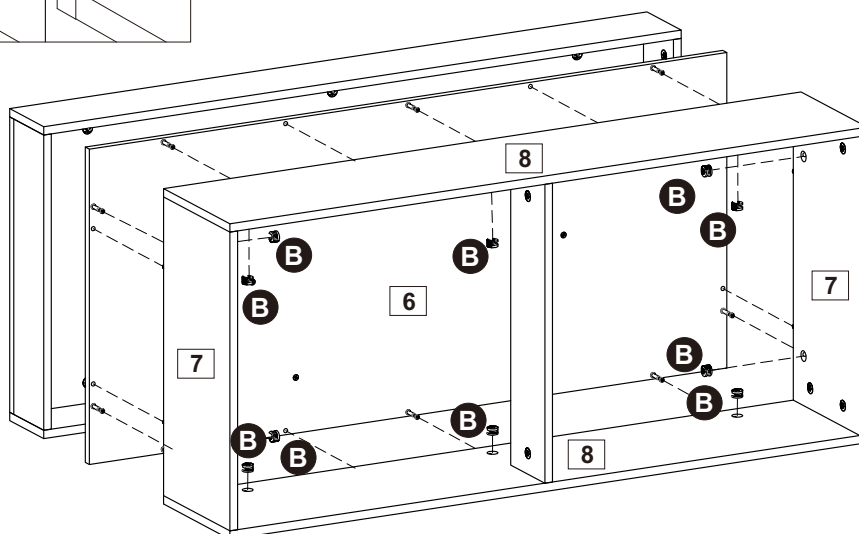

Connect components (7,8) to components (6), insert and lock cam lock (B).

Step 24

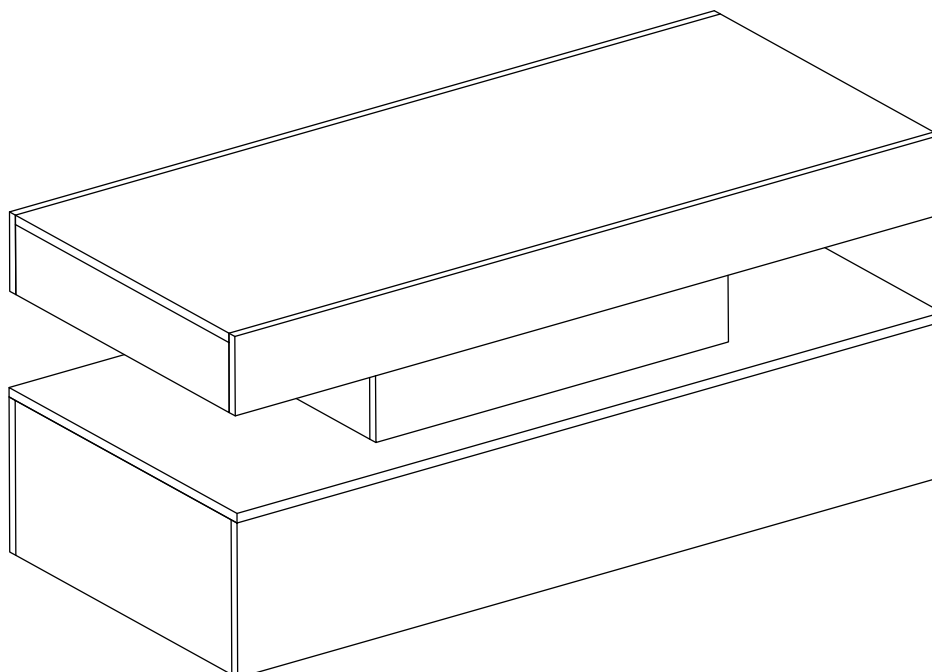

Assembly is complete.