

ASSEMBLY INSTRUCTION SHEET FOR BAR

STEP - 1

Lay the bar on its back on protective surface.

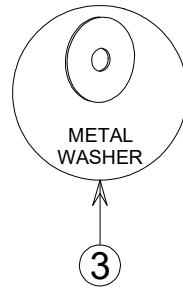
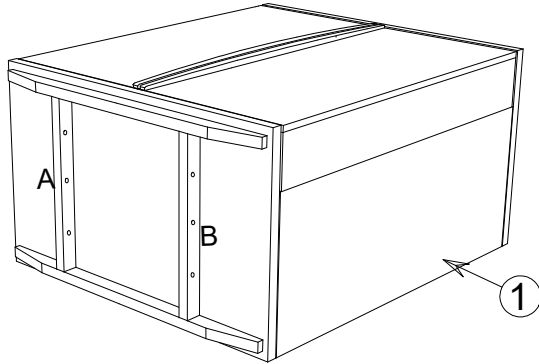

METAL WASHER

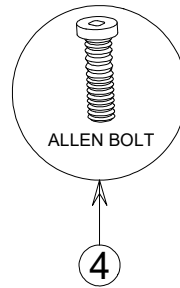

ALLEN BOLT

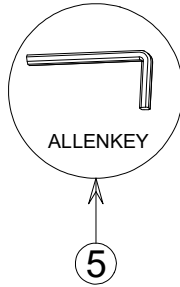

ALLENKEY

STEP - 2

Coordinate the numbers on leg & numbers on bar bottom apron. Align the holes on legs with holes on bar bottom.

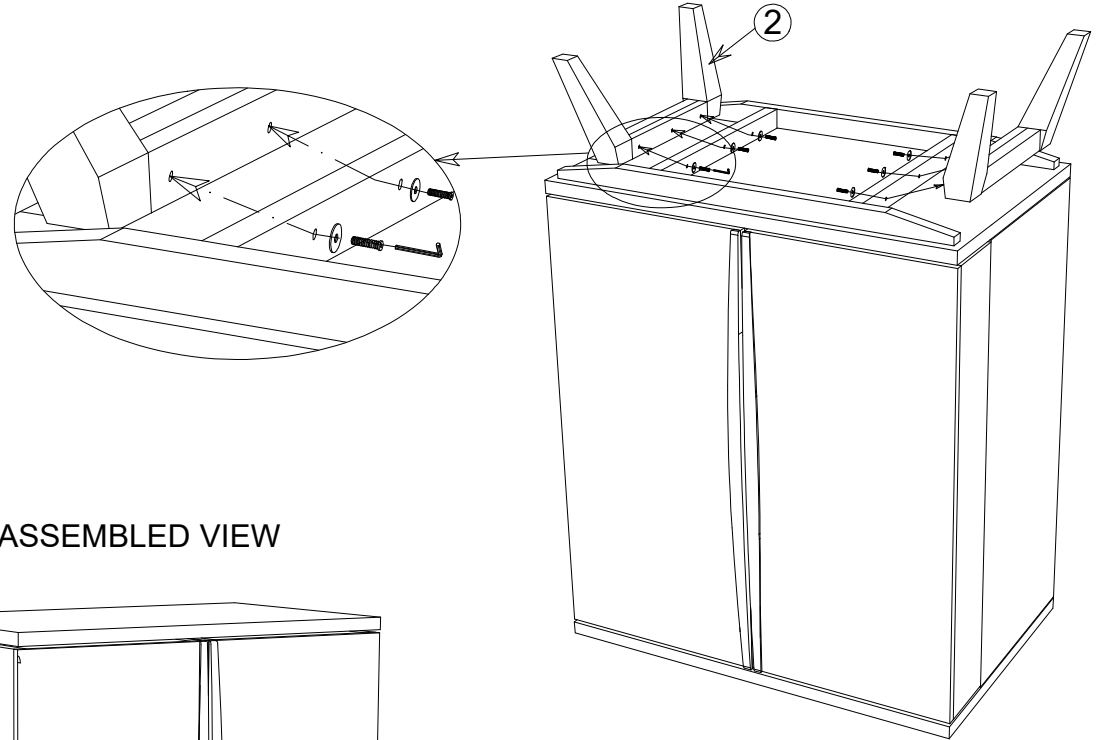

STEP - 3

Insert the allen bolt with metal washer & use the allenkey to tighten the allen bolt partly until all 3 bolts are engaged. Repeat step 2 once all 3 bolts are engaged, tighten fully.

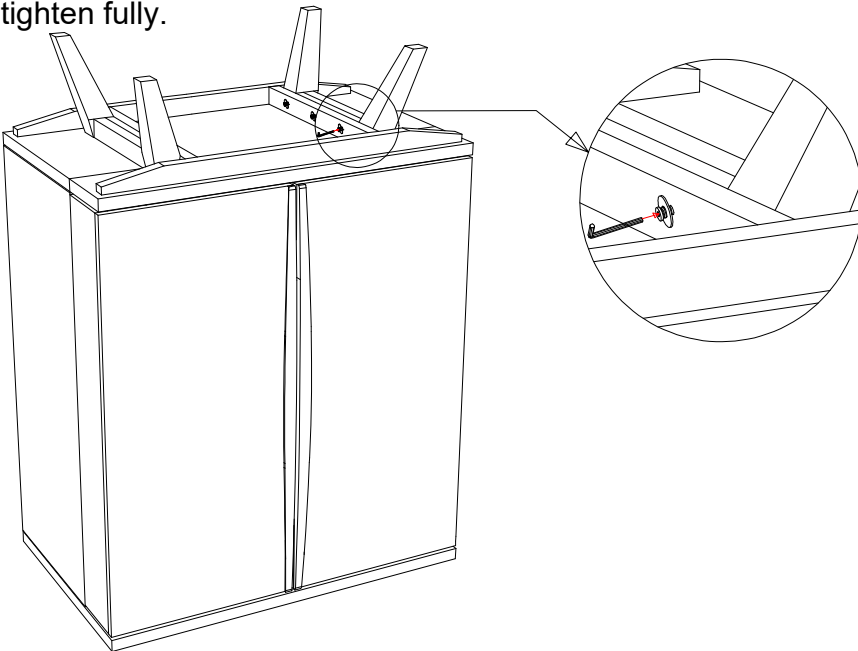

ASSEMBLED VIEW

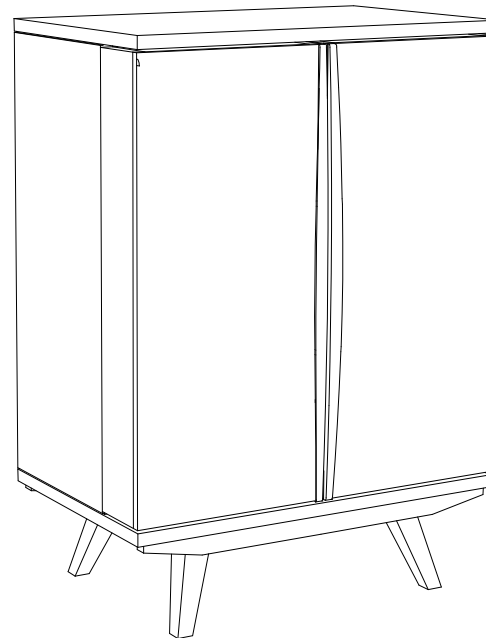

SIZE : 32 X 20 X 45 INCH

S.N.	PART LIST	SIZE	QTY.
1	BAR		1
2	LEG		2
3	METAL WASHER	8X25 MM	6
4	ALLEN BOLT	8X40 MM	6
5	ALLEN KEY	5 MM	1