

Installation & Assembly

TV Cabinet

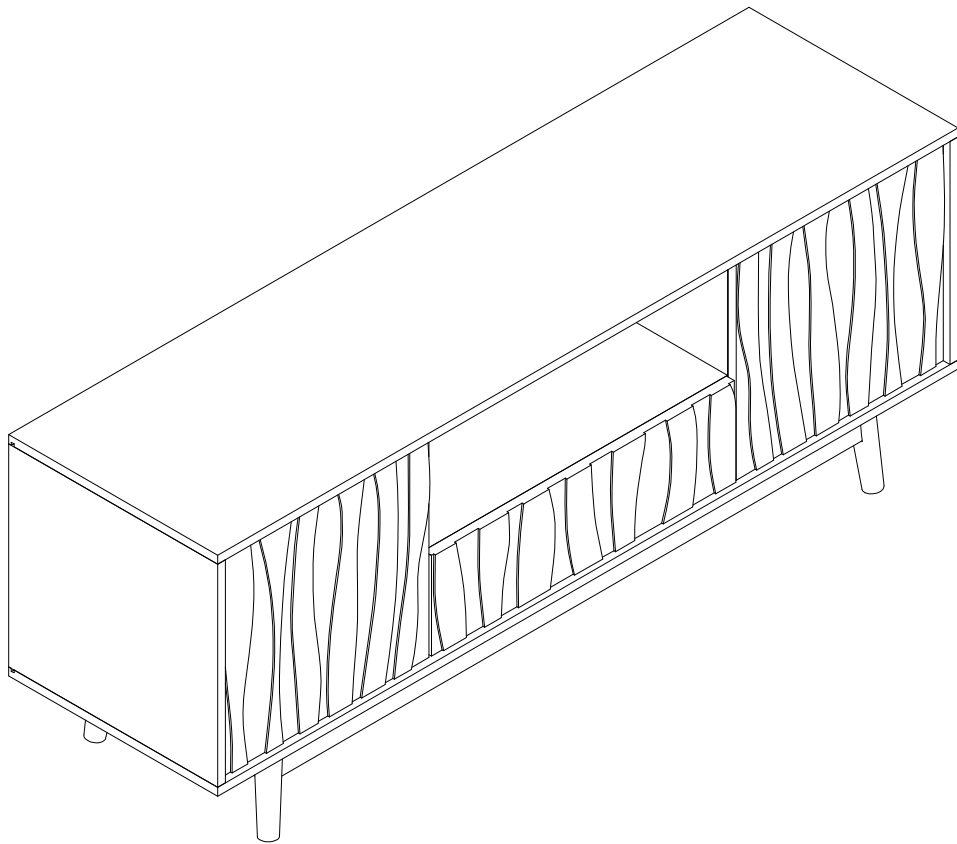

Each wooden board has an number sticker. Match them one-by-one according to the steps in the assembly manual.

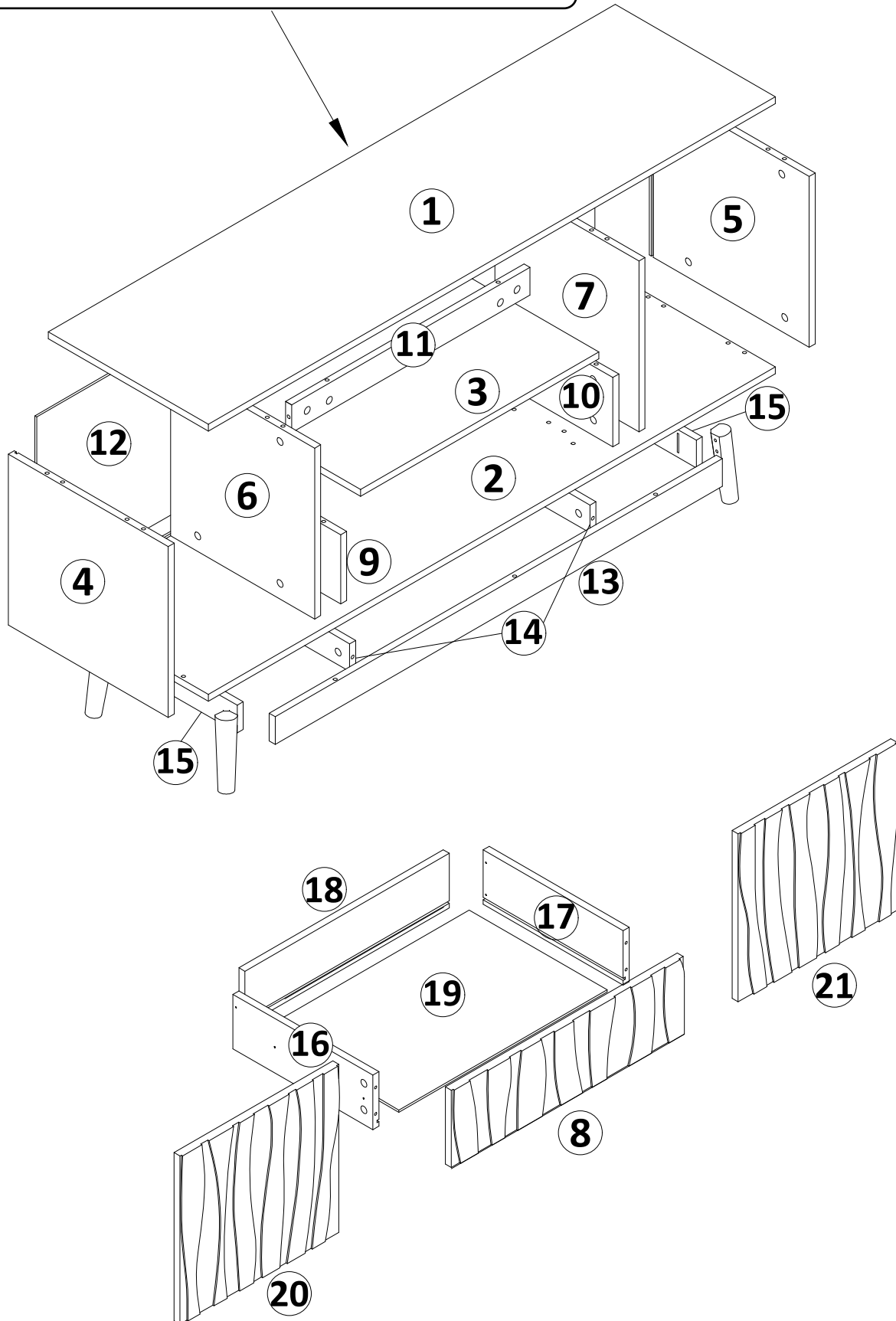

PARTS LIST

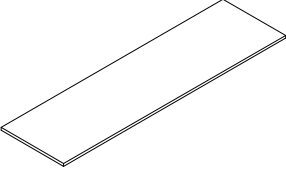
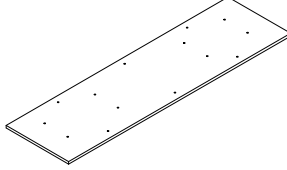
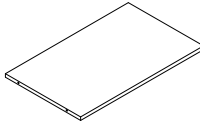
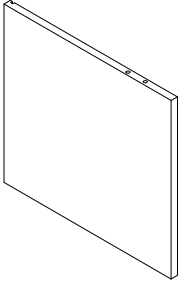
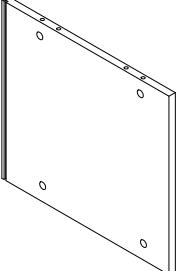
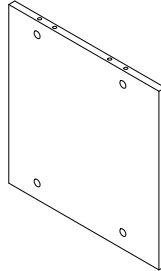
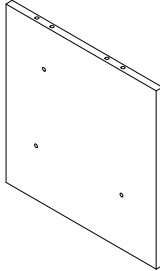
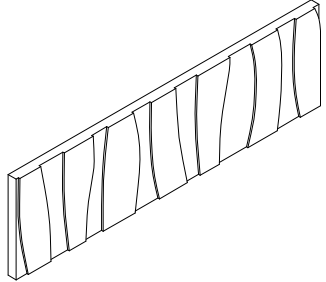
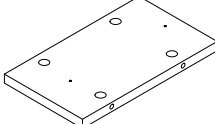
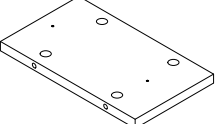
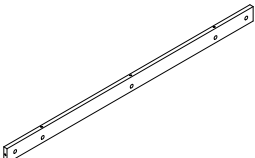
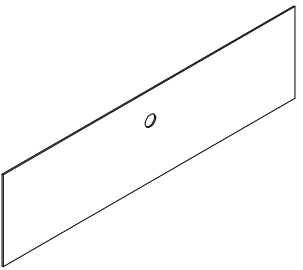
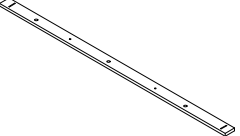
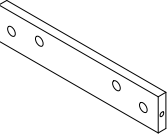
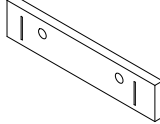
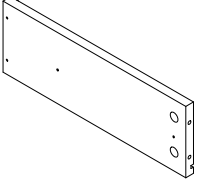
1 	2 	3 	4 
1PC	1PC	1PC	1PC
5 	6 	7 	8 
1PC	1PC	1PC	1PC
9 	10 	11 	12 
1PC	1PC	1PC	1PC
13 	14 	15 	16 
2PCS	2PCS	2PCS	1PCS

PARTS LIST

17

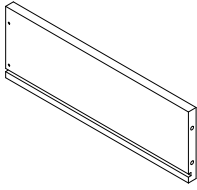

1PCS

18

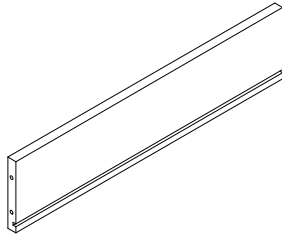

1PCS

19

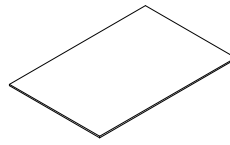

1PCS

20

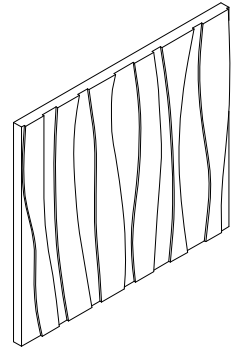

1PCS

21

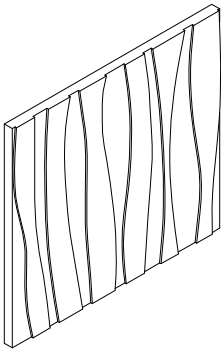





1PCS

·The number in the upper left corner indicates the panel code, and the number in the lower middle indicates the quantity.

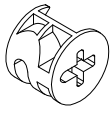
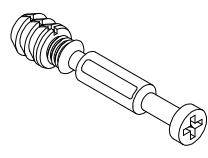
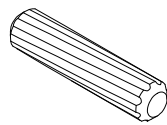
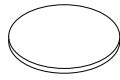
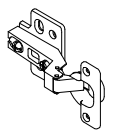
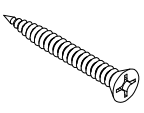
·If you encounter any missing or damaged panels, please contact us immediately. We will prioritize resolving your issue promptly.

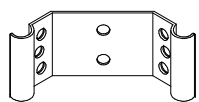
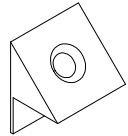
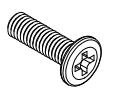
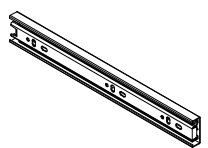
HARDWARE LIST

A	B	C	D	E
				
Ø15*10MM 54PCS	Ø6*35MM 54PCS	Ø7*38MM 16PCS	Ø20MM 16PCS	4PCS
F	G	H	I	J
				
Ø3.5*35MM 4PCS	Ø3.5*14MM 62PCS	4PCS	6PCS	Ø6*25MM 8PCS
K	L			
				
10" 2PCS	150MM 4PCS			

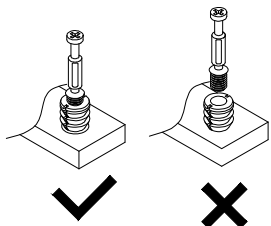
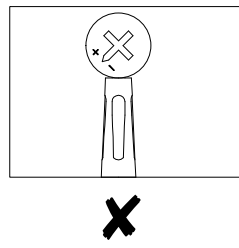
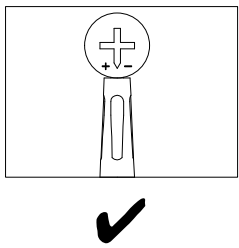
 <p>This part cannot be separated, please install in strict accordance with the assembly requirements.</p>	 <p>Adjust connecting piece direction until it is properly lined up with the hole.</p>	 <p>Insert bolt when connecting piece direction is properly lined up.</p>
---	---	--

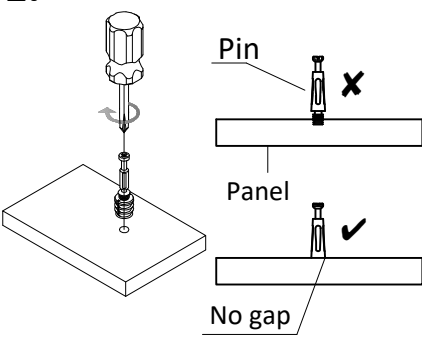
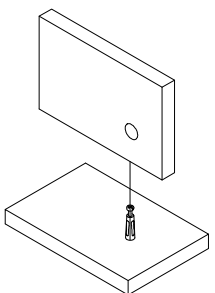
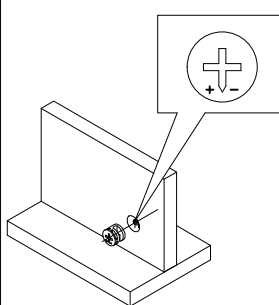
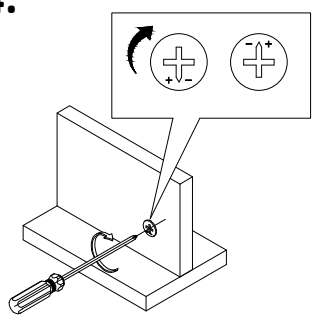
1. 	2. 	3. 	4. 
--	---	--	---

Step 1

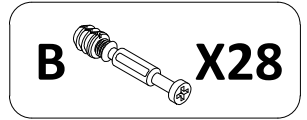

As shown in the diagram, screw #B (connector bolt) into the corresponding holes of the Panels 2/3/6/7/13 (x2).

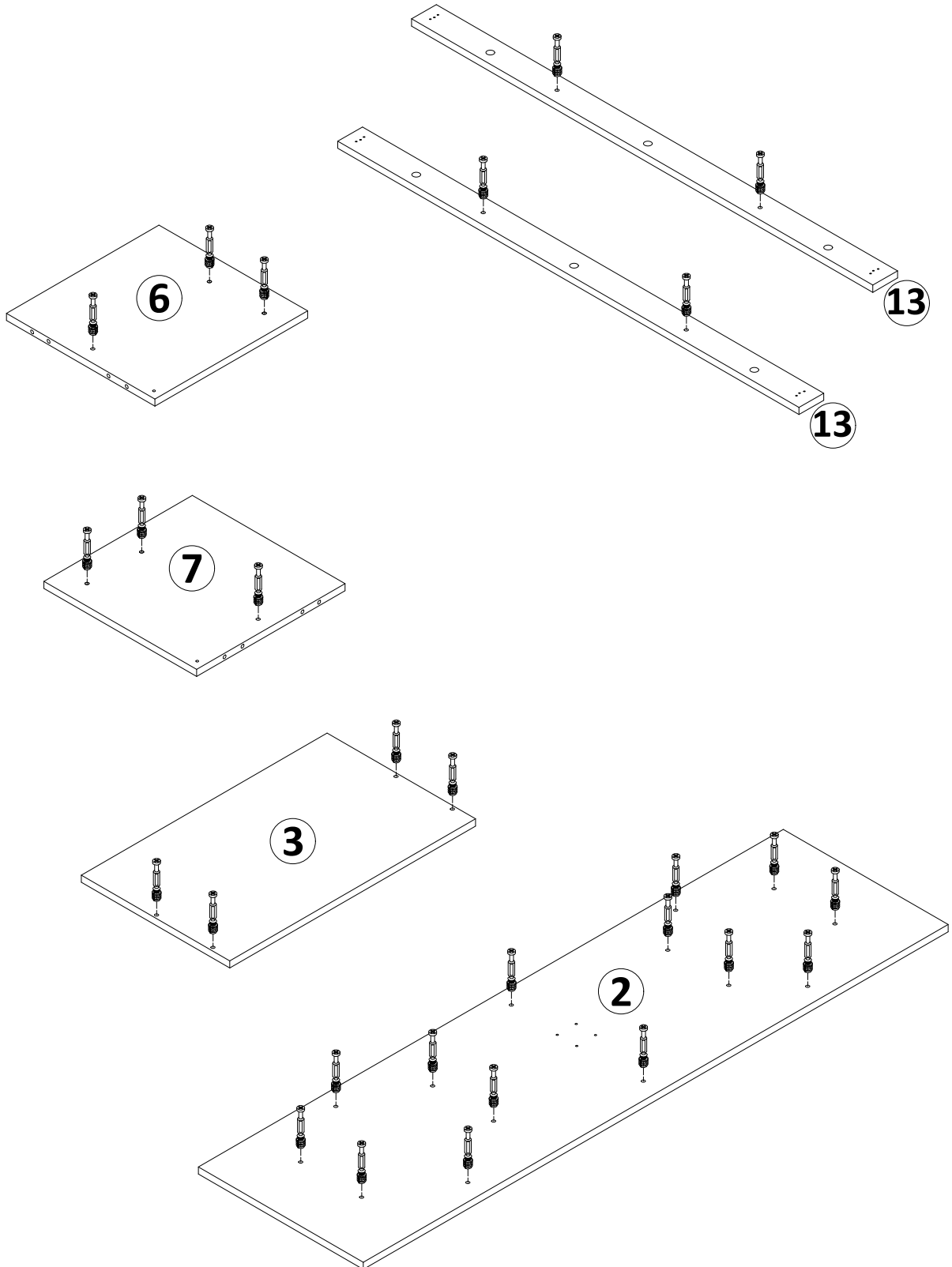

Step 2

As shown in the figure, install the two Panels 14 with the holes on the long sides facing downwards between the two Panels 13 (with the holes on the long sides facing downwards) and screw in #A (eccentric cam lock).

A  **X4**

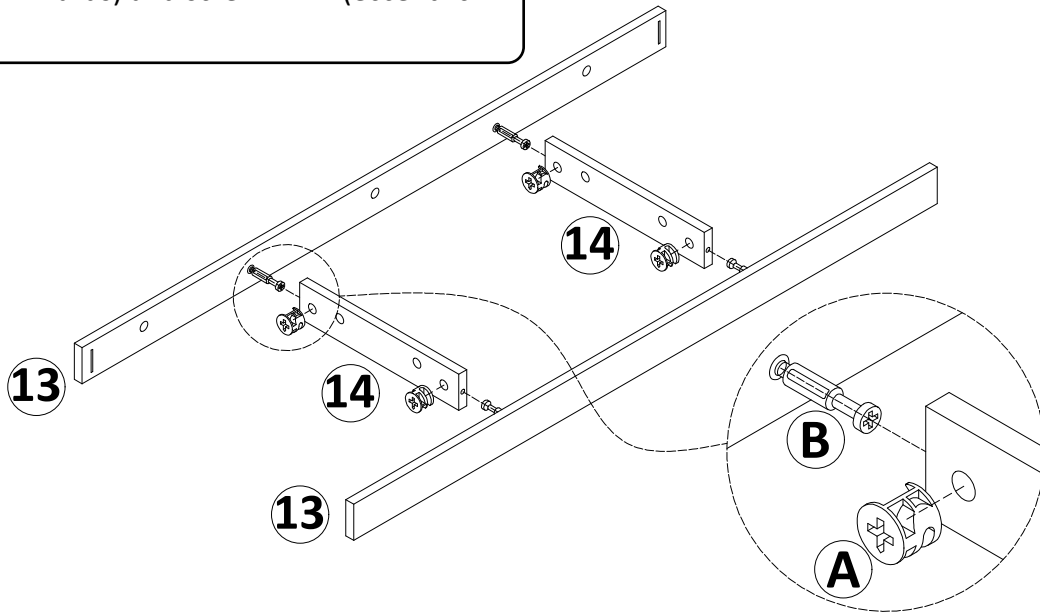

Step 3

Note: When installing Panels 13, 14, and 15, make sure the side with the holes is facing down.

1. Snap the #N fittings into the grooves on the edges of Panels 13 and 15 to secure the four corners.

2. Place the #L (wooden legs) as shown. Connect #N and #L with two #J (screws), and finally secure the sides of #N with #G (screws).

3. Follow the above steps to install the remaining #L.

G  **X24**

J  **X8**

L  **X4**

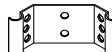
N  **X4**

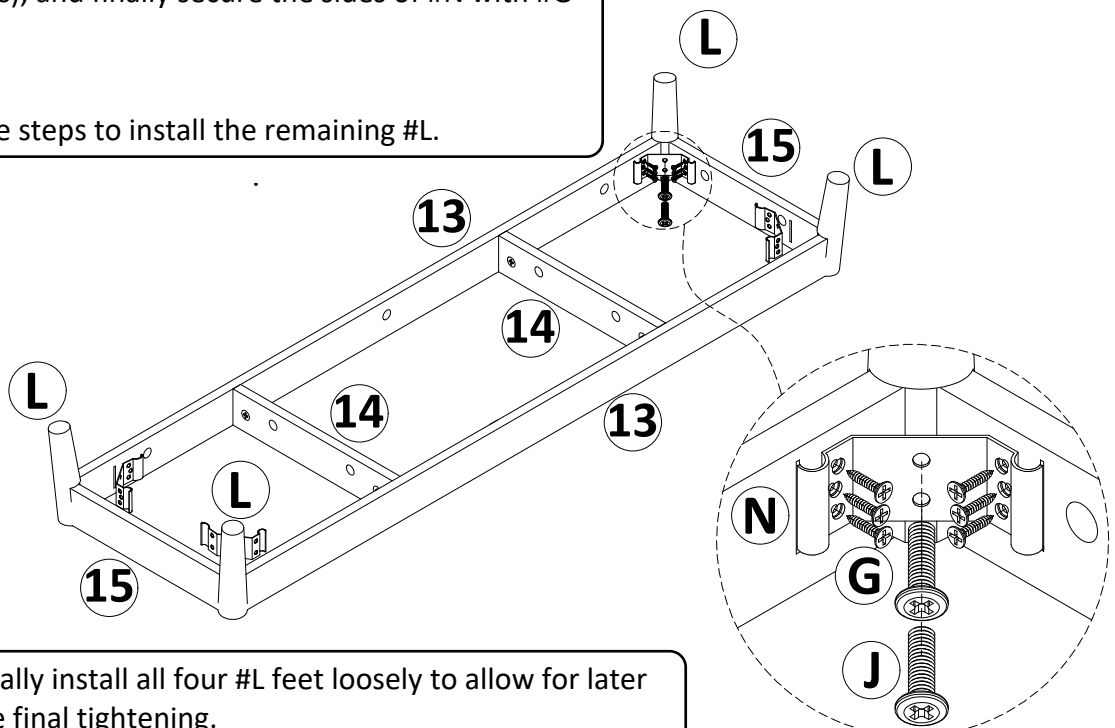

Assembly Tip: Initially install all four #L feet loosely to allow for later adjustment before final tightening.

Step 4

Align TV stand base frame with Panel 2, connect and secure with #A (eccentric locks) and tighten.

A  **X14**

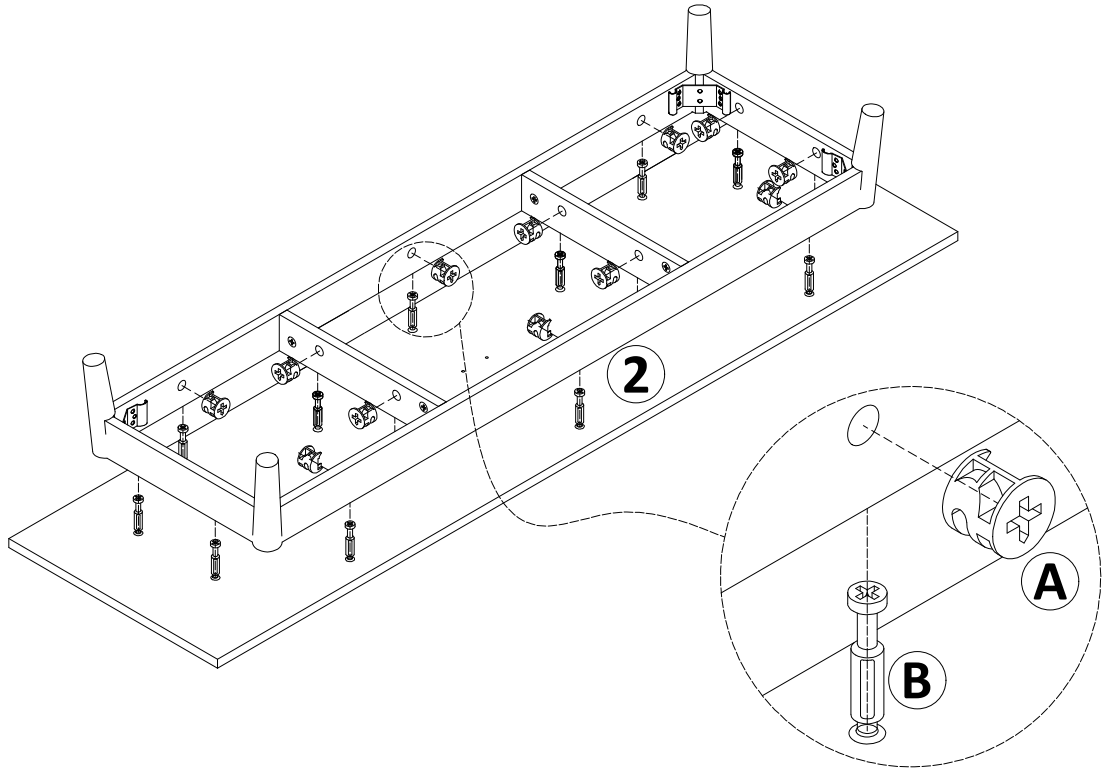

Step 5

Screw screw #B (connector bolt) into the front of Panel 2.

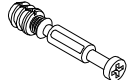
B  **X12**

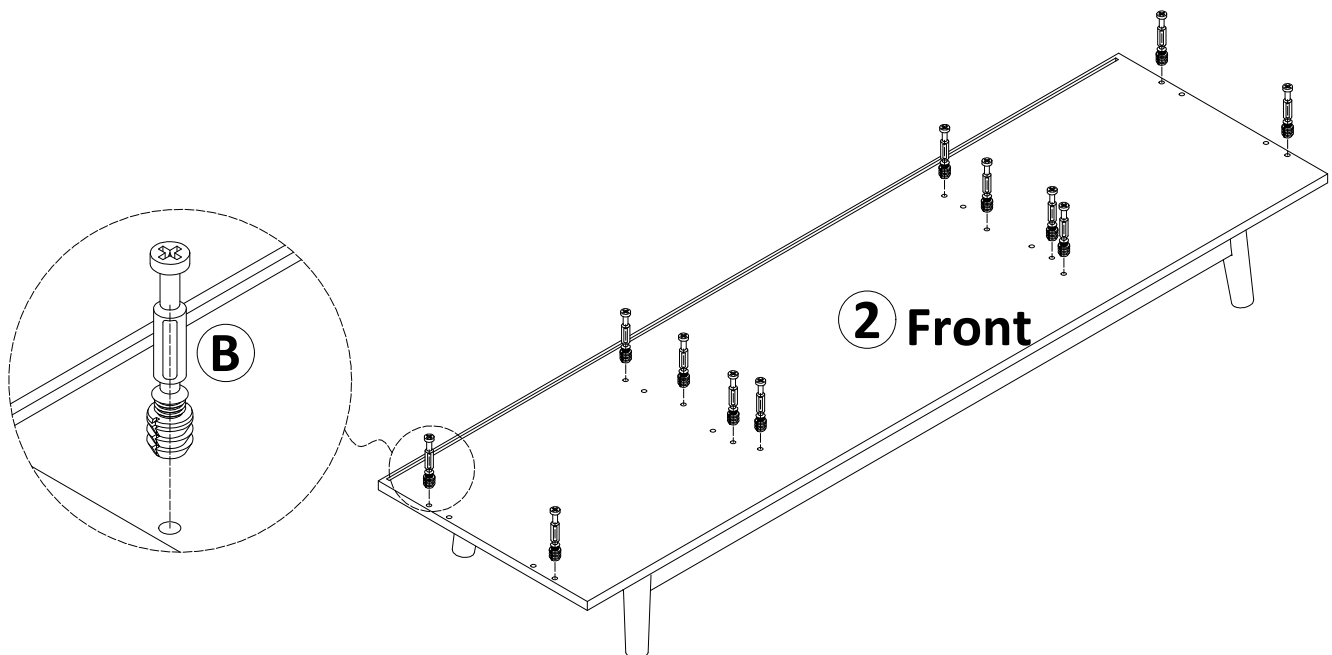

Step 6

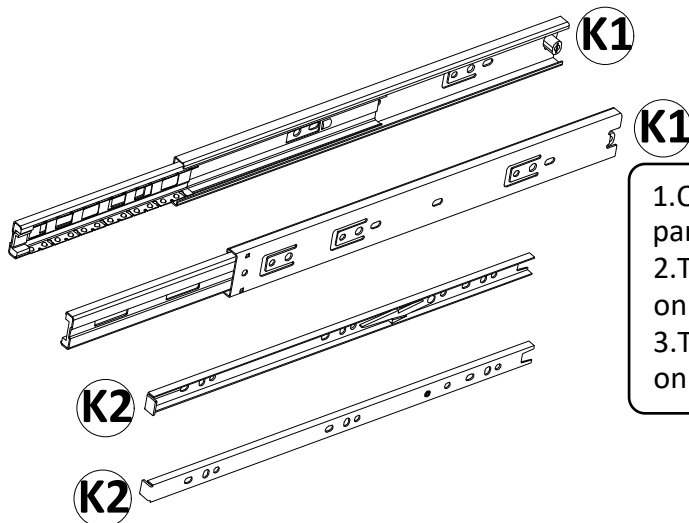
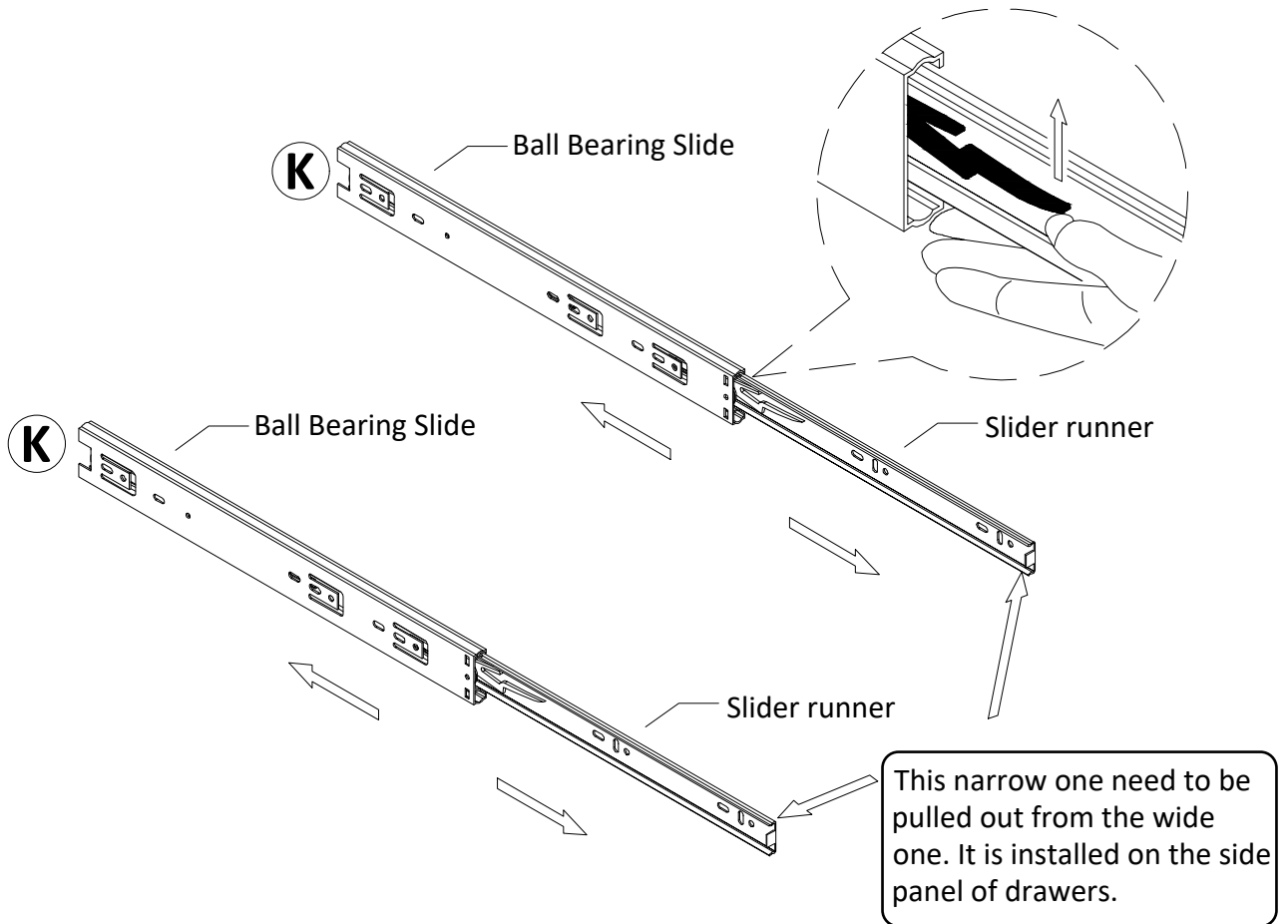

1. One set of guide rail should be four parts.
2. Two wide guide rails are installed on the side panel of the cabinet.
3. Two narrow guide rails are installed on the side panel of drawers.

Attention:
Take care when installing the slide rails as they have been pre-lubricated.

Step 7

As shown: Secure two K1 units to Panels 9 and 10 using #G (screws).

G  **X4**

K1  **X2**

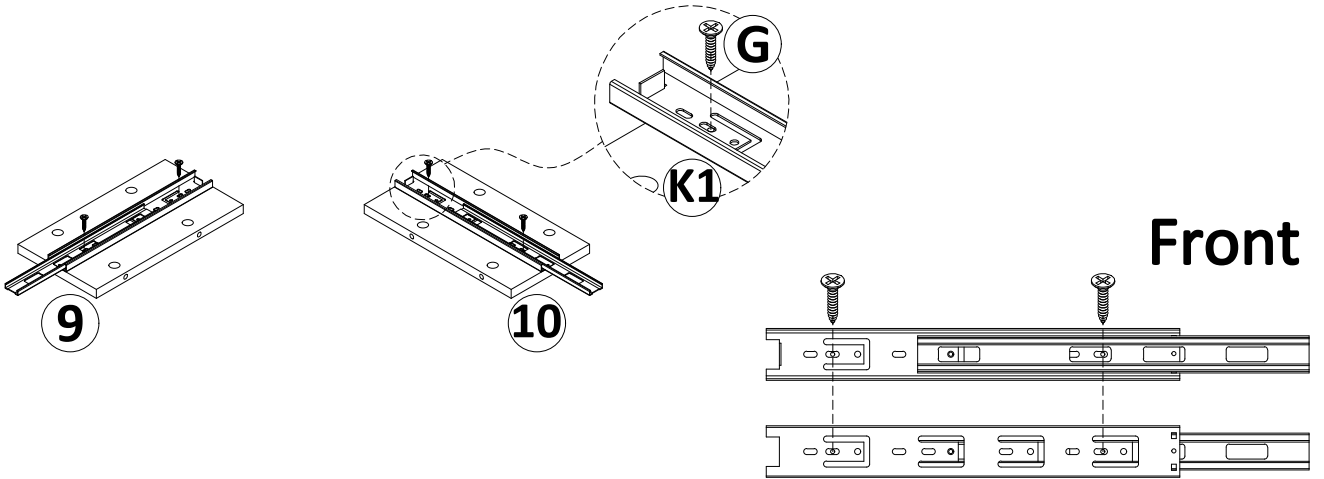

Step 8

Insert Panel 9/10 to Panel 2, then secure with #A (eccentric locks) and tighten.

A  **X4**

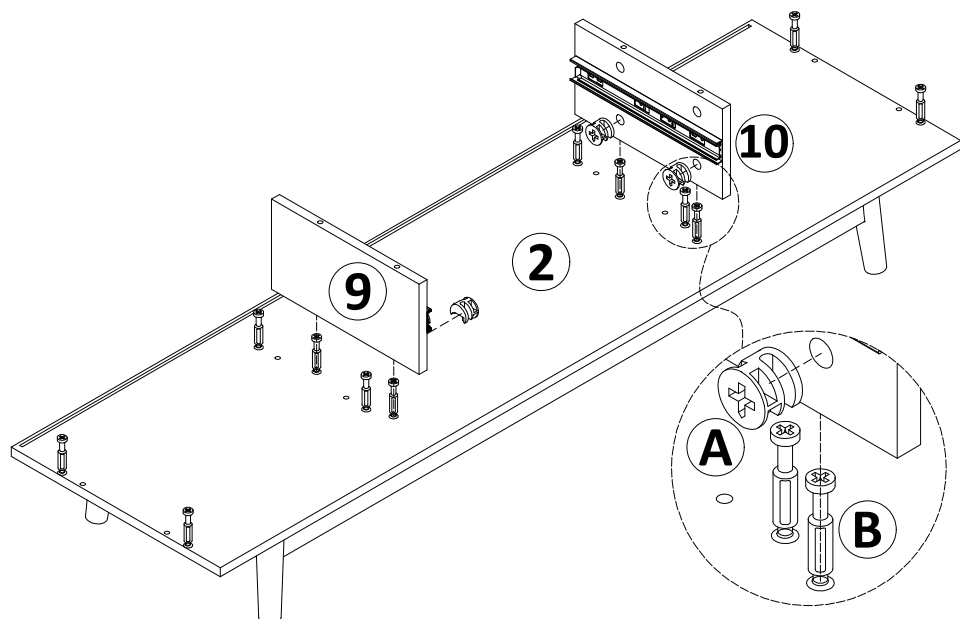

Step 9

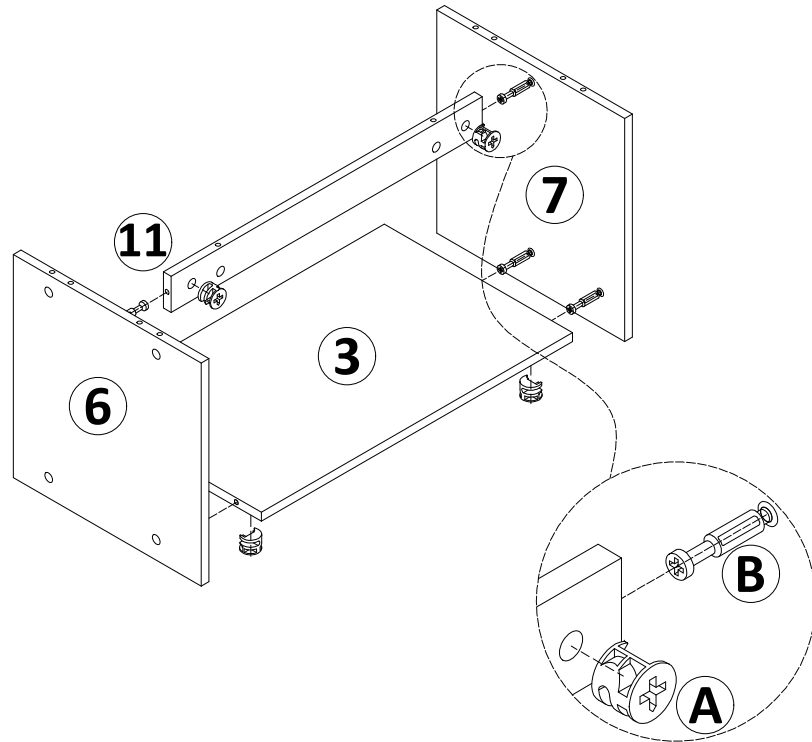

Insert Panels 6 & 7 into the sides of Panels 3 & 11 as shown in the figure, and screw in screws #A (eccentric locks) to secure both sides.

A  **X6**



Step 10

1. Screw #C (wood dowel pins) into Panel 2;
2. Then install the entire pre-assembled part (Panels 6/7/11) onto Panel 2 and screw in screw #A (eccentric locks) to secure.

A  **X8**
C  **X4**

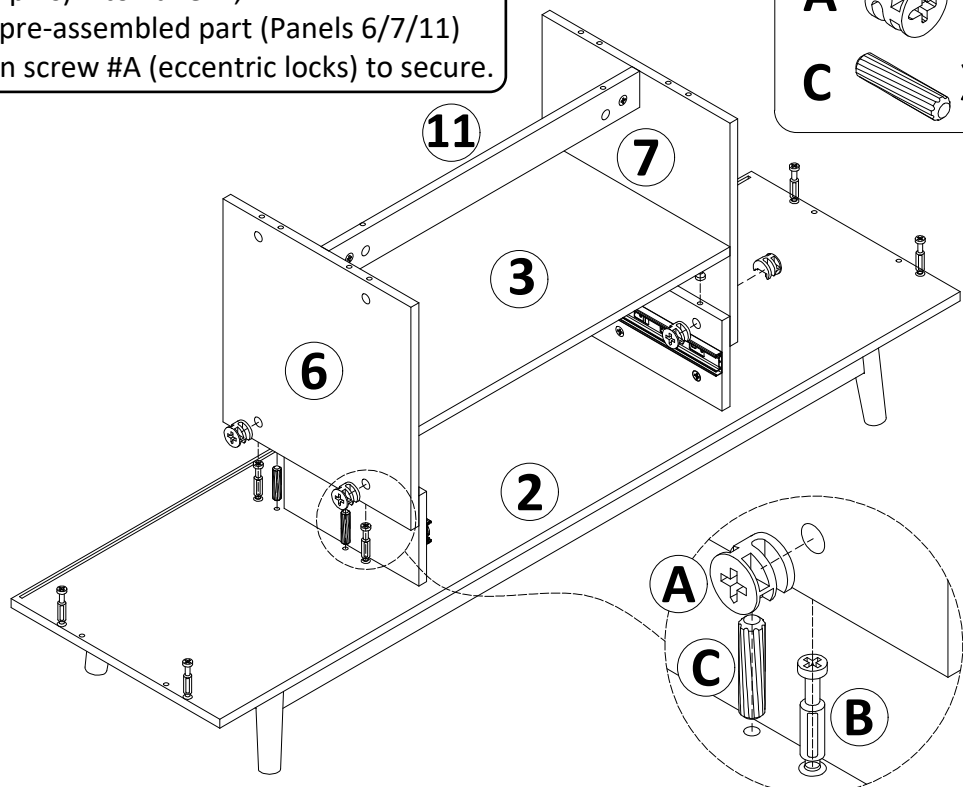

Step 11

1. As shown, insert #C (wood dowel pins) into the designated holes of Panel 2.
2. Then, snap Panels 4 and 5 onto Panel 2 and secure with screws #A (eccentric locks).

When assembling, align the grooves of Panels 4 and 5 with Panel 2.

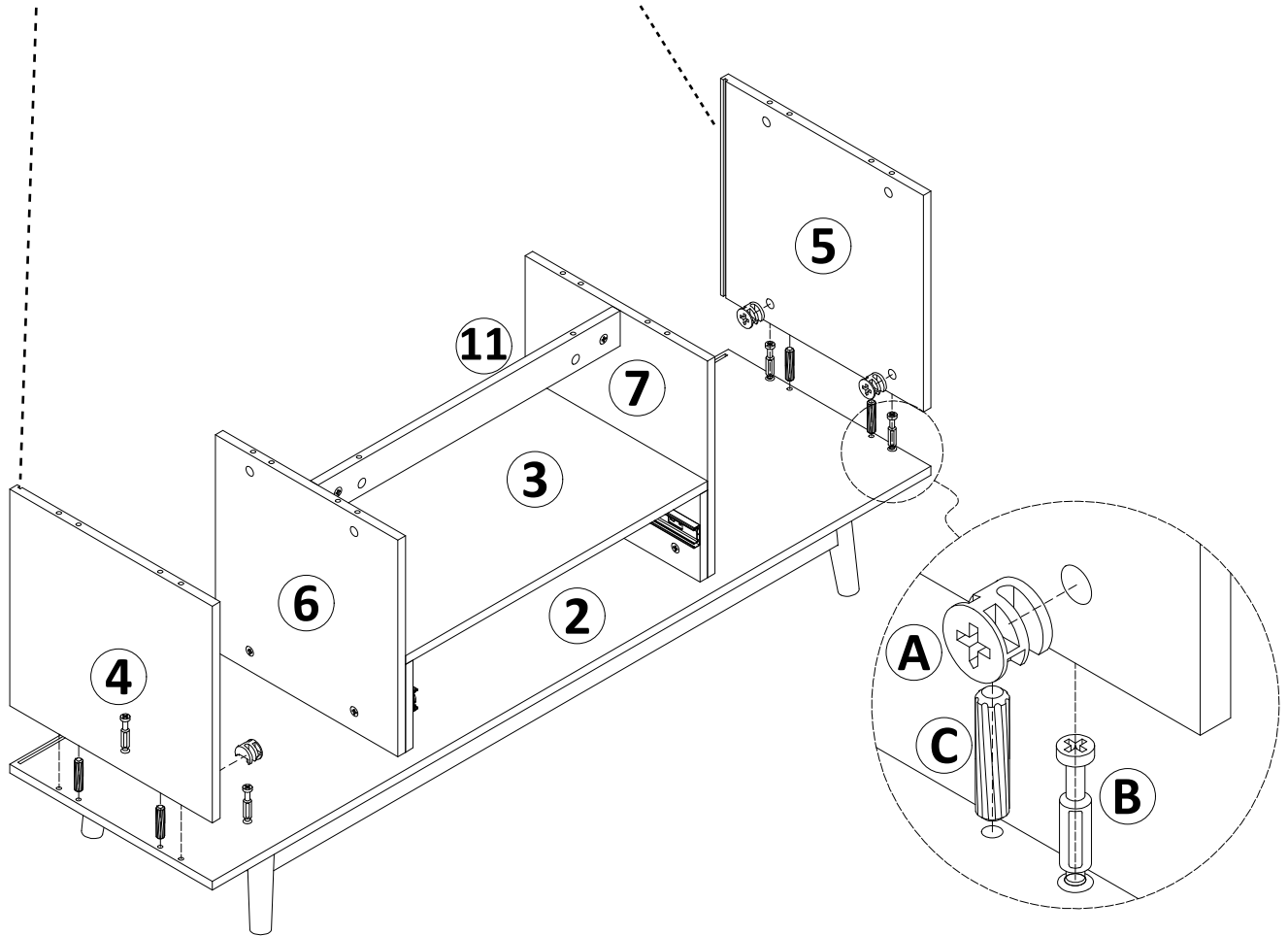
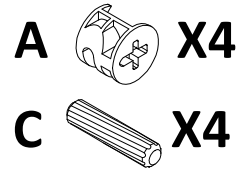

Step 12

Snap the Panel 12 into the groove.

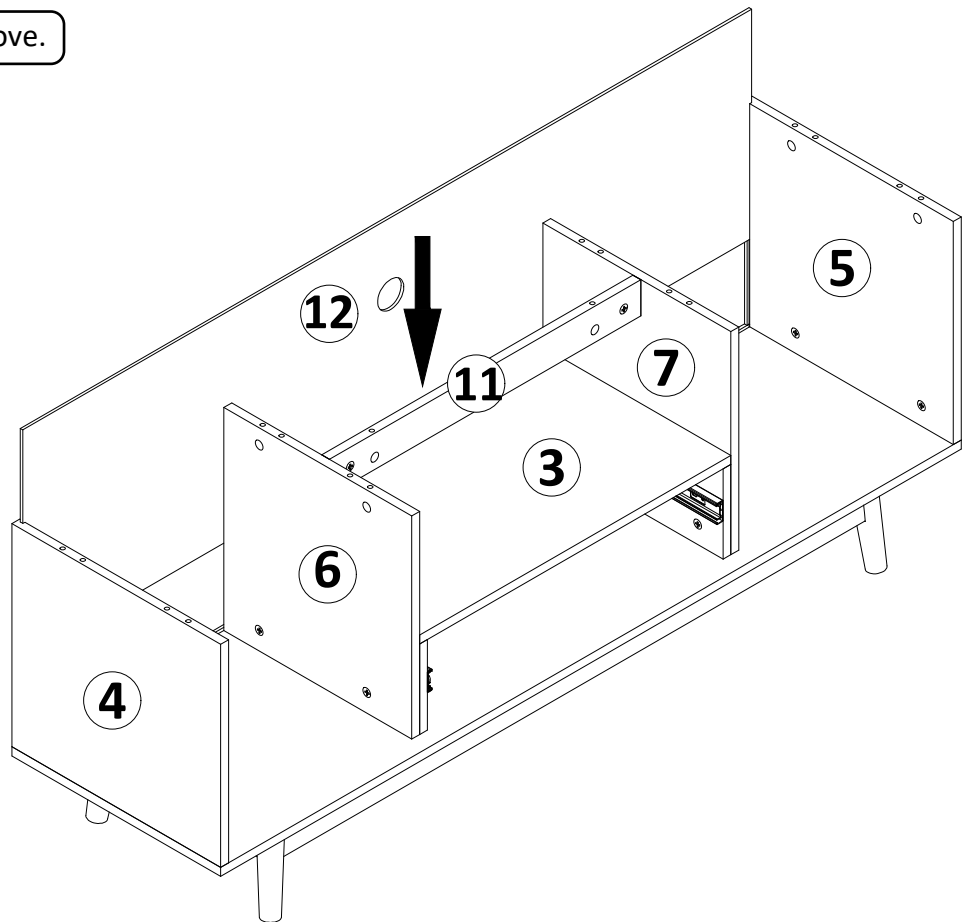

Step 13

Install screw #B (connector bolt) on Panel 1/8.

B **X14**

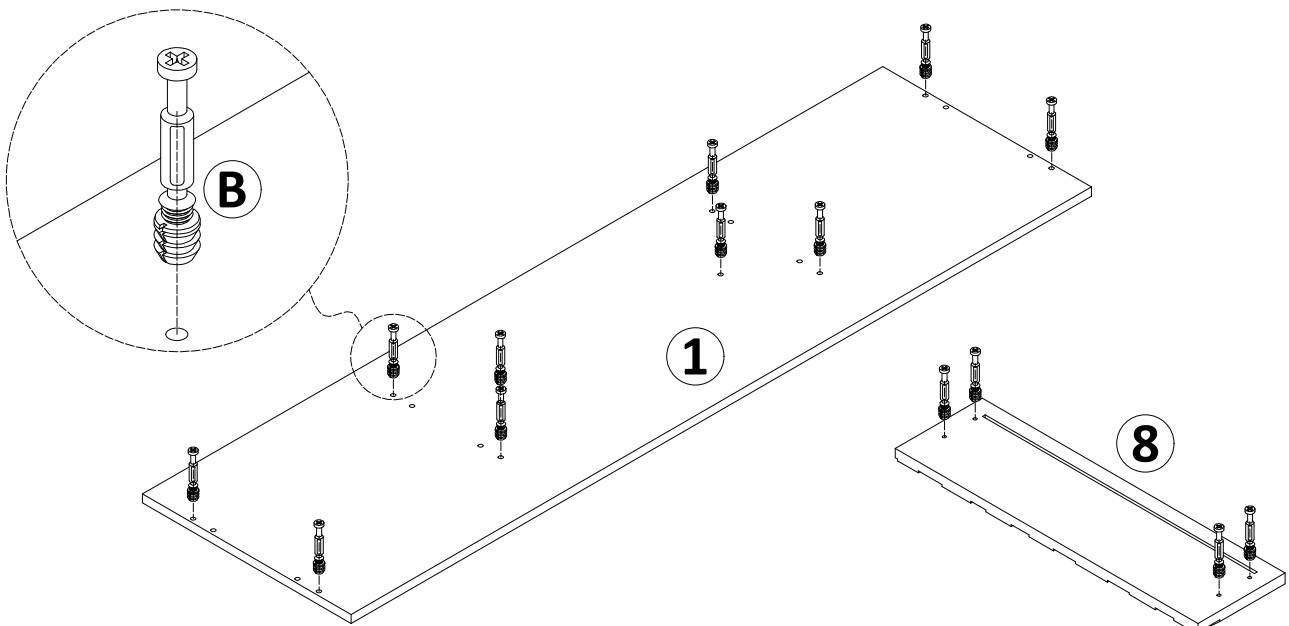

Step 14

1. Insert #C (wood dowel pins) into the pre-drilled holes and attach Panel 1. Attach #A (eccentric cam lock) to the corresponding holes and tighten to lock.

A  **X10**

C  **X8**

H  **X1**

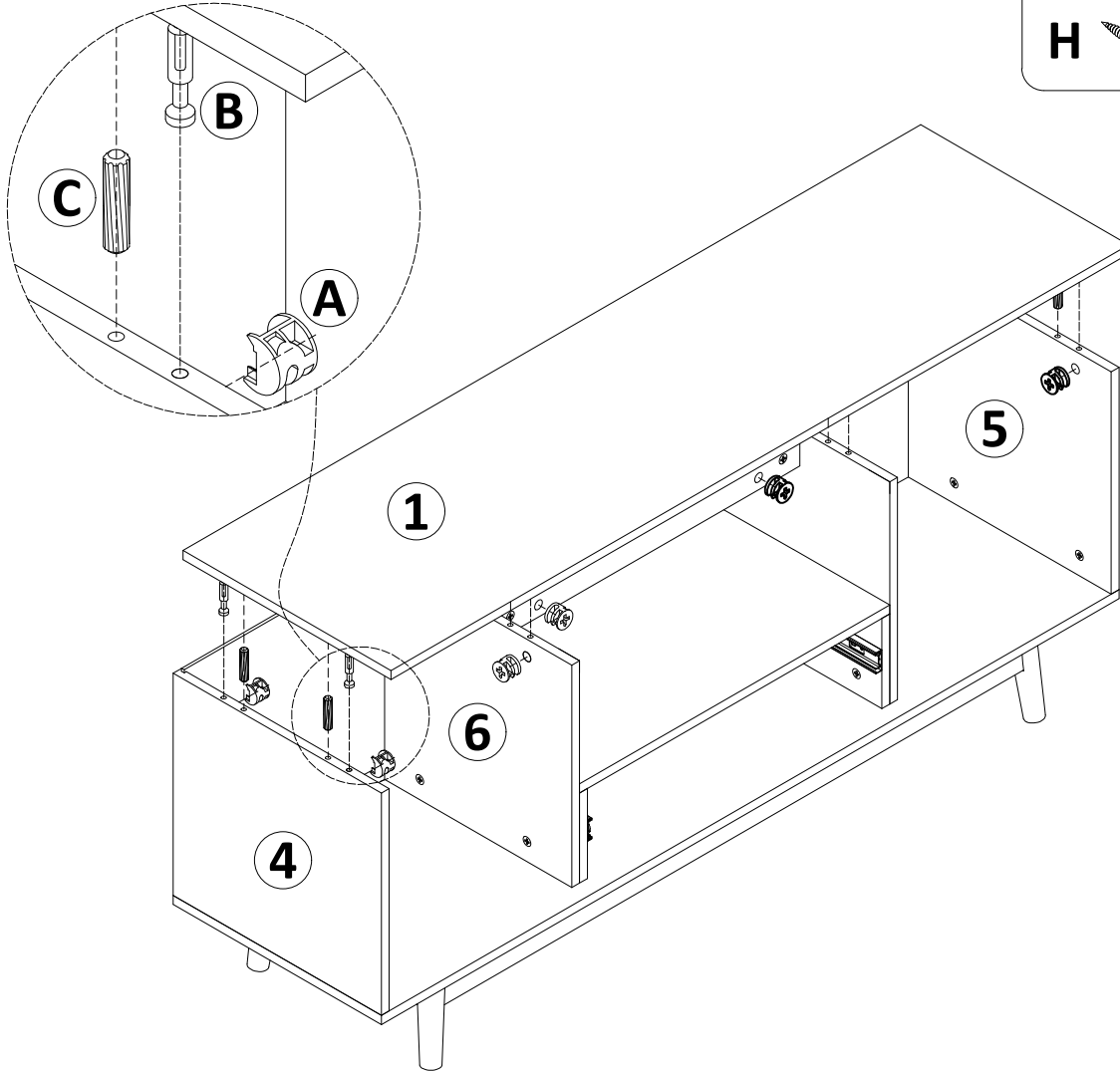

Step 15

F  **X4**

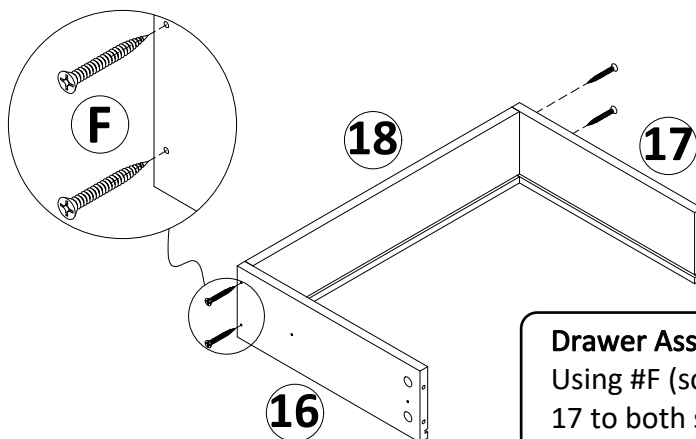

Drawer Assembly:

Using #F (screws) secure Panel 16 and Panel 17 to both sides of Panel 18, ensuring the grooves are aligned in the same direction.

Step 16

Snap Panel 19 into the groove.

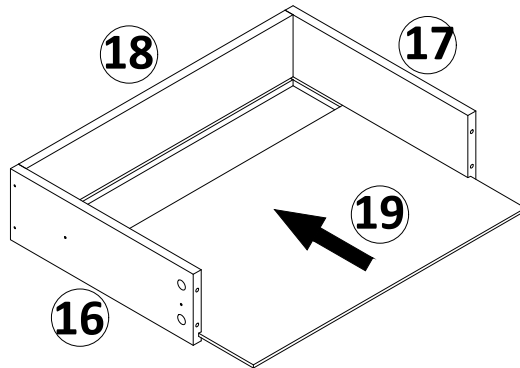

Step 17

Install Panel 8 (drawer front) to the pre-drawer assembly and secure it by screwing #A (eccentric cam lock) into the side mounting holes.

A  **X4**

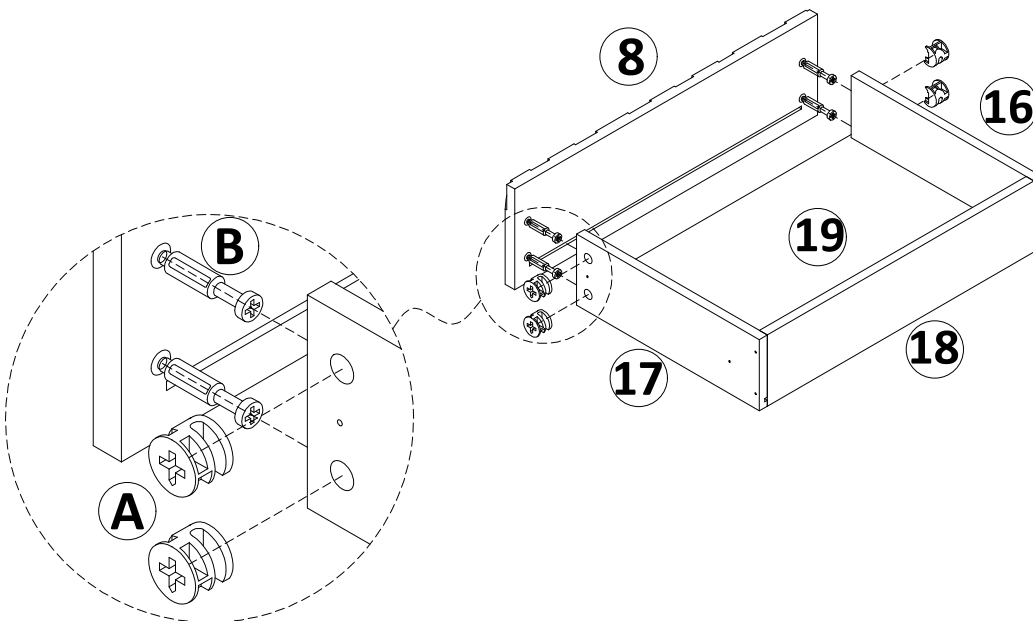

Step 18

Attach the K2 (inner rails) to both sides of the drawer using the #G (screws).

G  **X4**

K2  **X2**

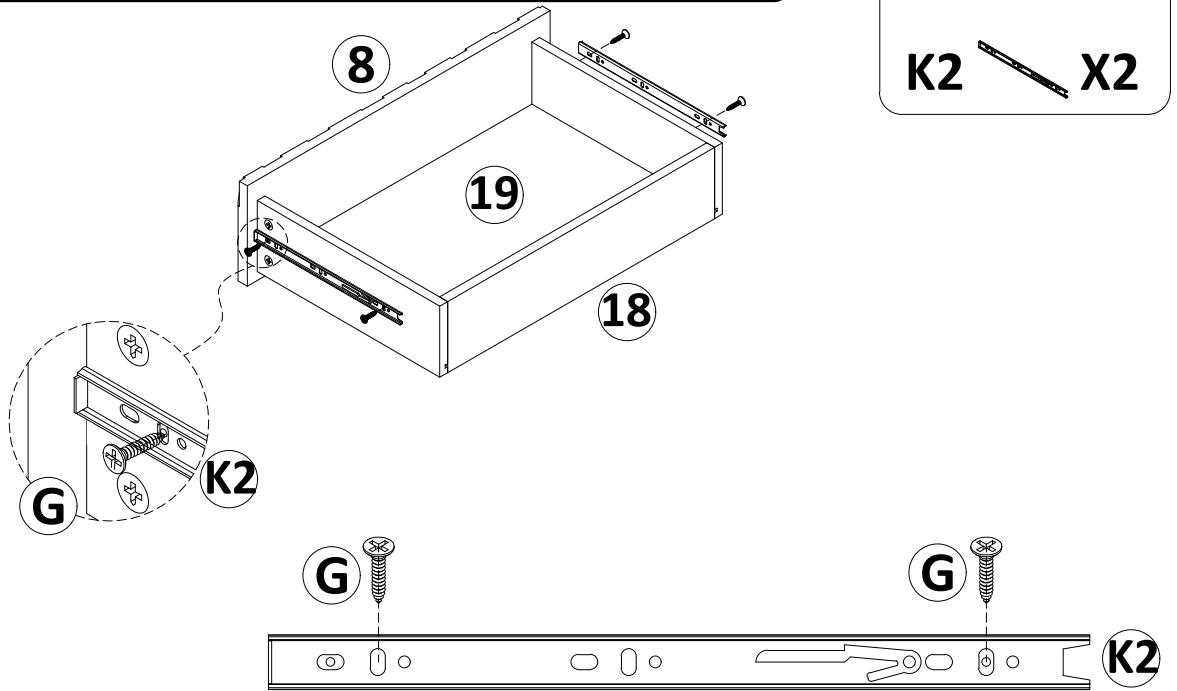

Step 19

Slide the drawer with the installed inner rails into the corresponding slots in the cabinet until it clicks into place.

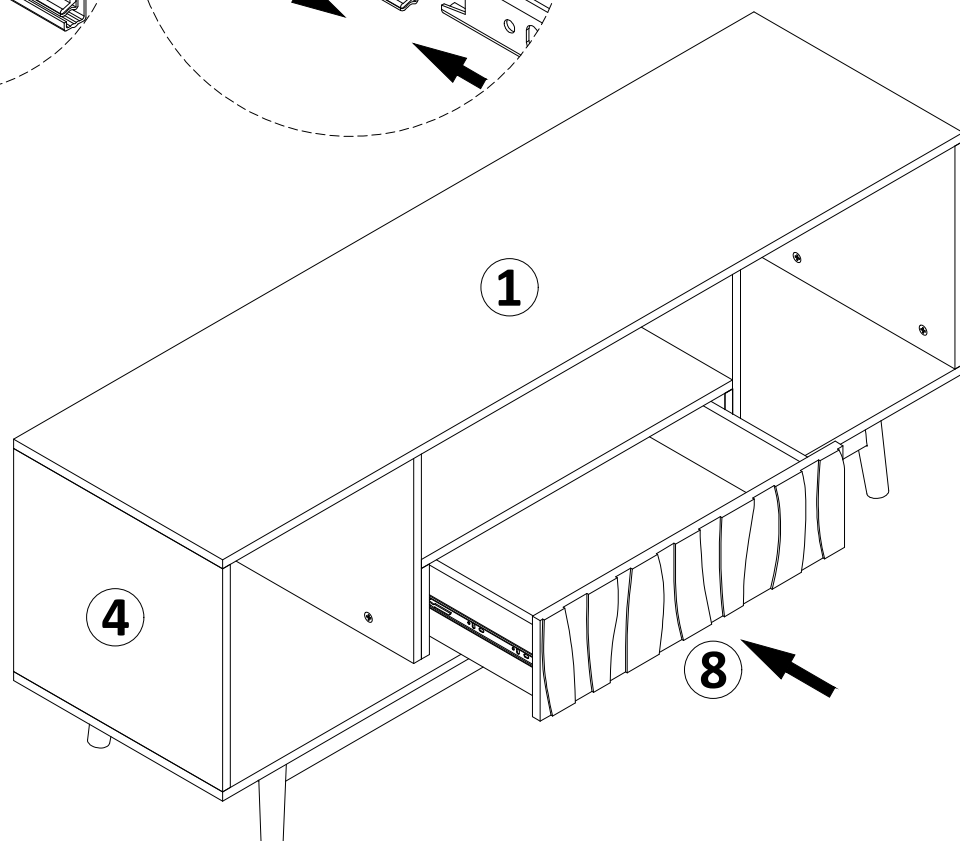
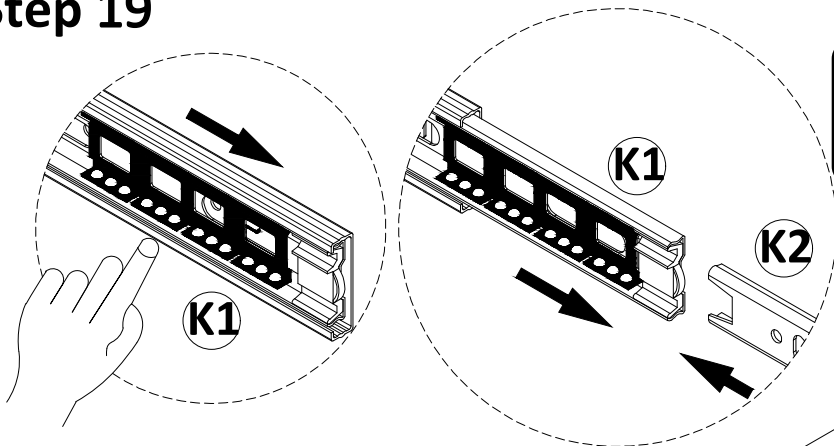

Step 20

As shown in the figure, install the #E (door hinge) to the designated position on Panels 20 and 21 and tighten the #G (screws) to secure.

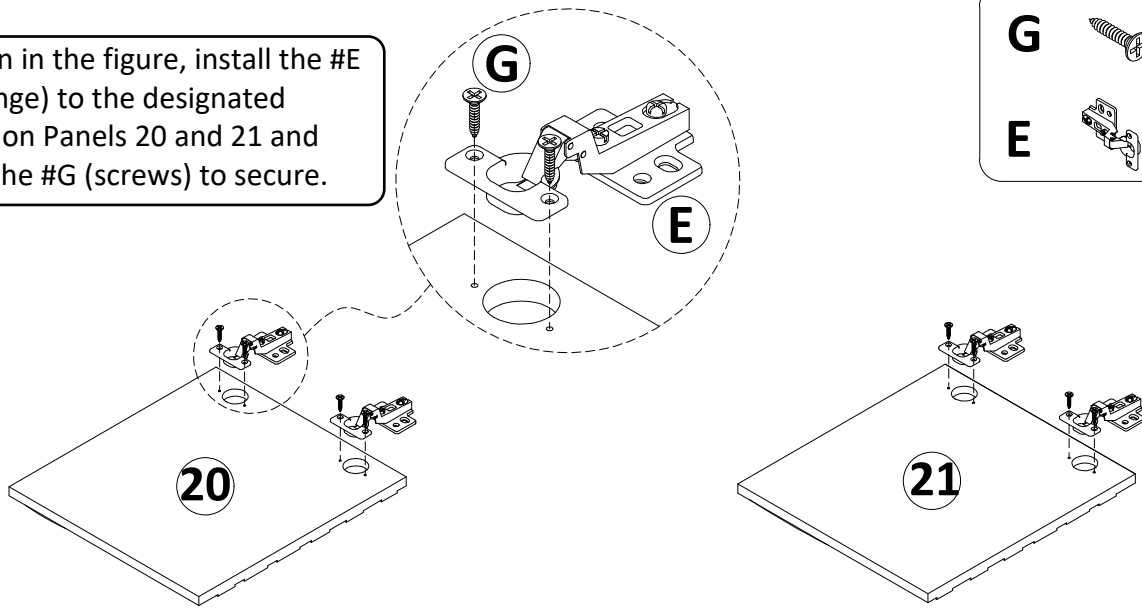

Step 21

As shown, attach Panels 20 and 21 to the cabinet using #E (door hinges) and tighten with #G (screws).

G X16

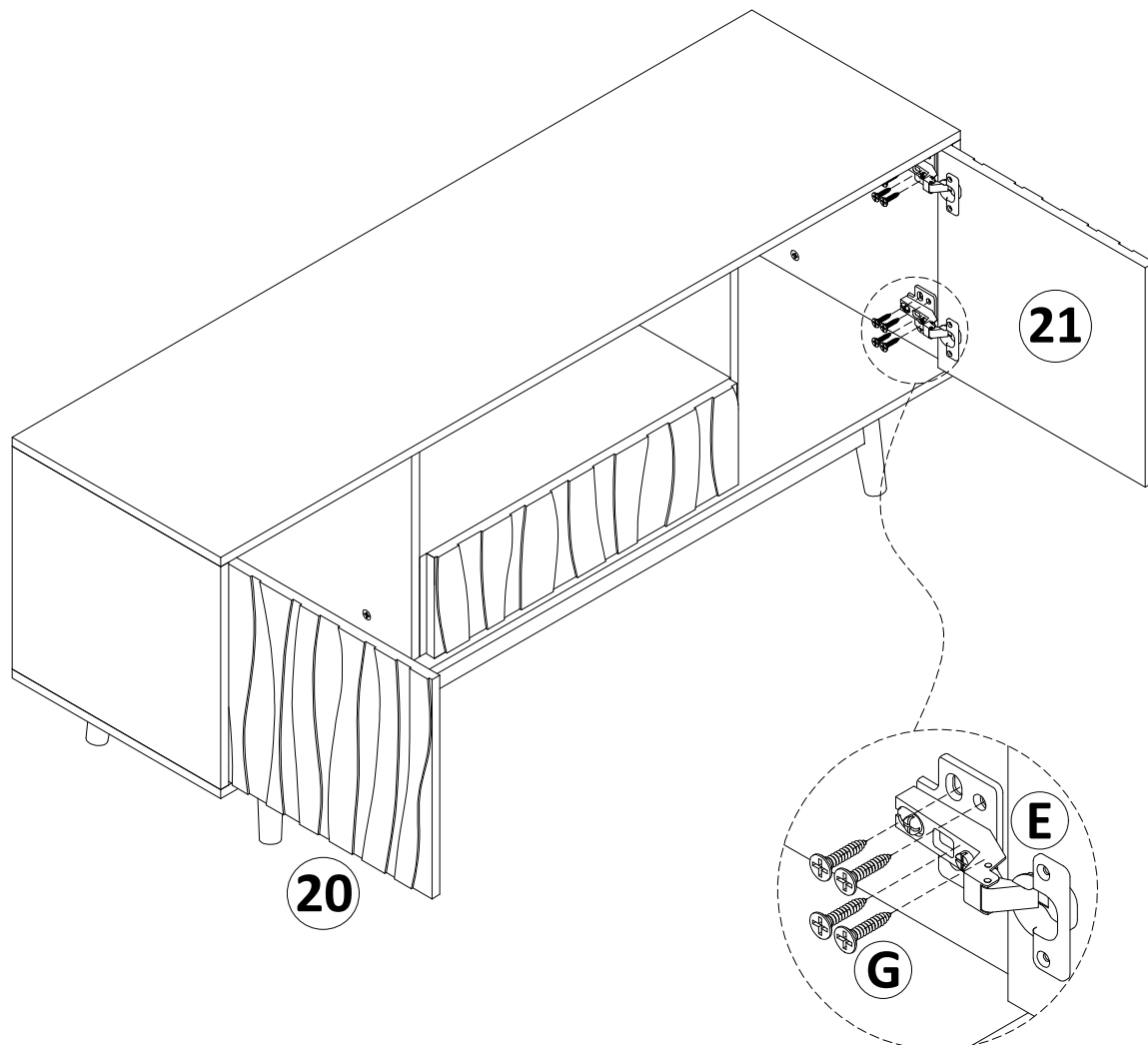

Step 22

Hinge Adjustment Diagram

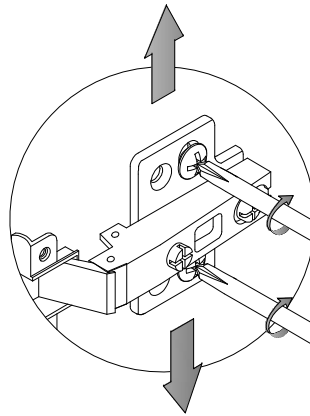
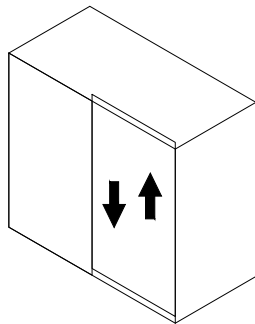
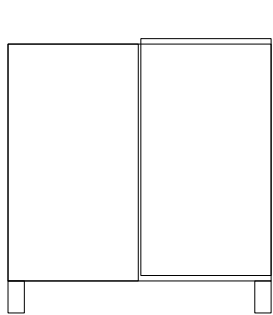
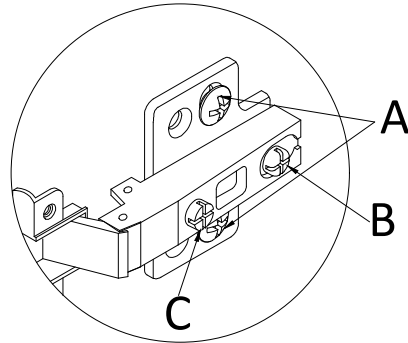

To adjust the vertical height.

Loosen the four screws labeled 'A' on both hinges. Two of these screws are usually in slotted holes, allowing for adjustment up or down by a few mm. After making the adjustment, tighten the screws back into place.

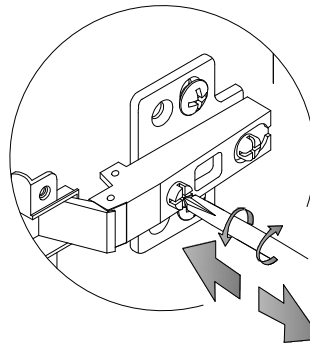
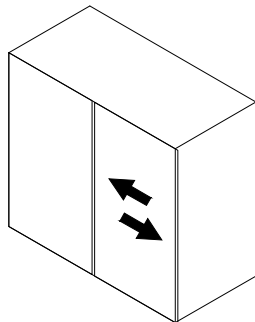
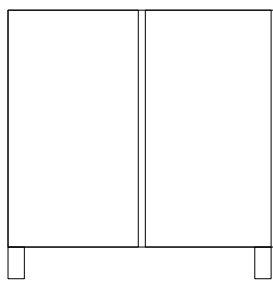

To adjust depth.

Loosen screw 'B' and adjust the door. If the door cannot be adjusted, loosen screw 'C' and try adjusting again. Once adjusted, tighten screws 'B' and 'C'.

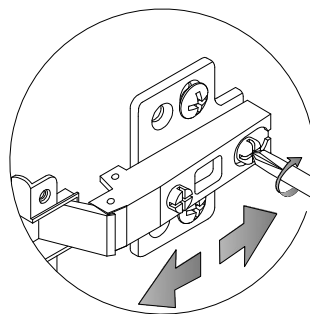
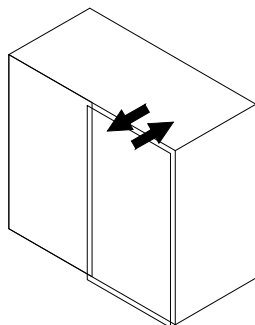
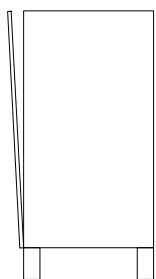

To adjust side ways.

After loosening the 'C' screw, you can adjust the distance from the door to the cabinet. After the adjustment is completed, tighten the 'C' screw again.

Step 23

Place the #D (hole sticker) inside the cabinet to cover the position of the #A (eccentric cam lock).

D  **X16**

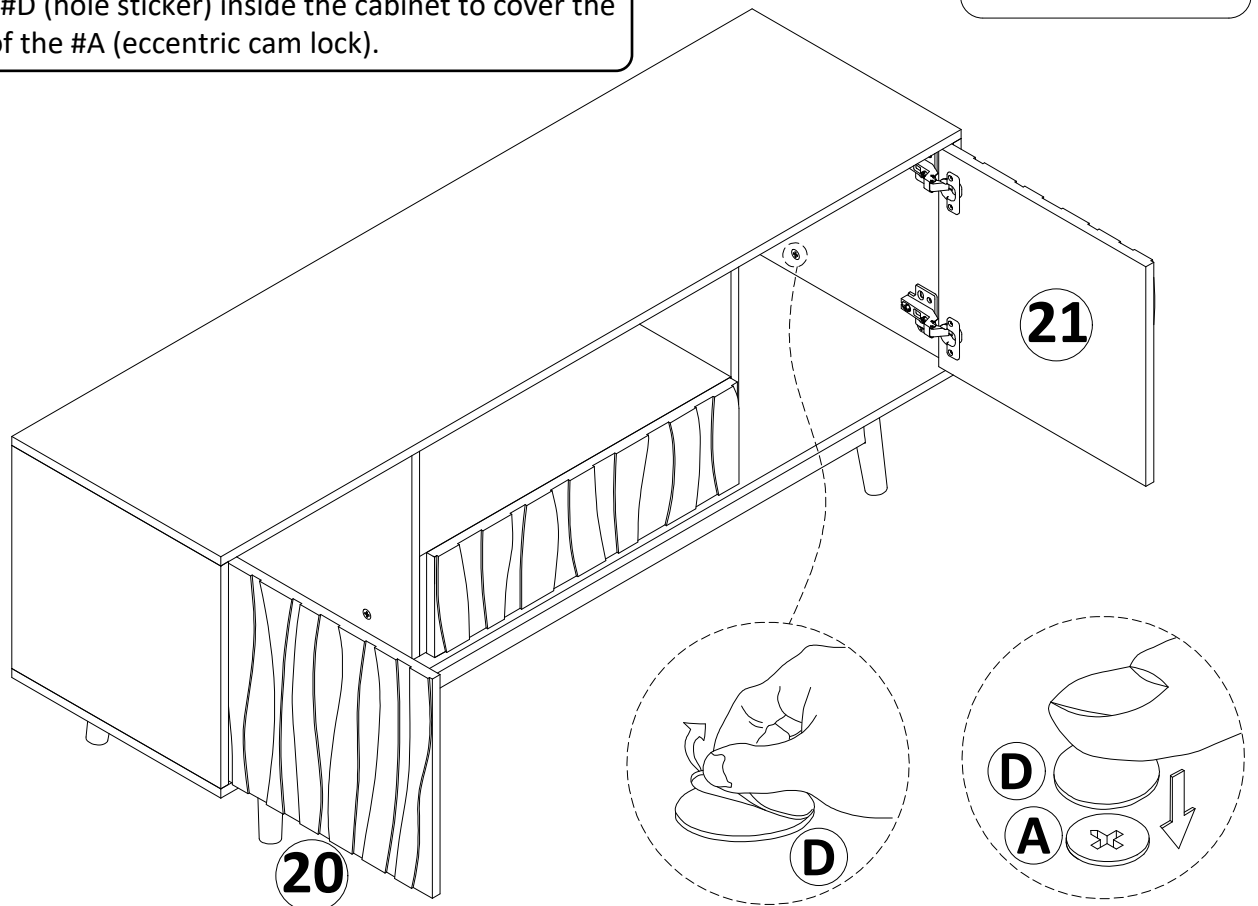

Step 24

As shown in the picture, use #G (screws) to fix the #I (backplate bracket) accessories to the backplate.

G  **X6**

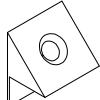
I  **X6**

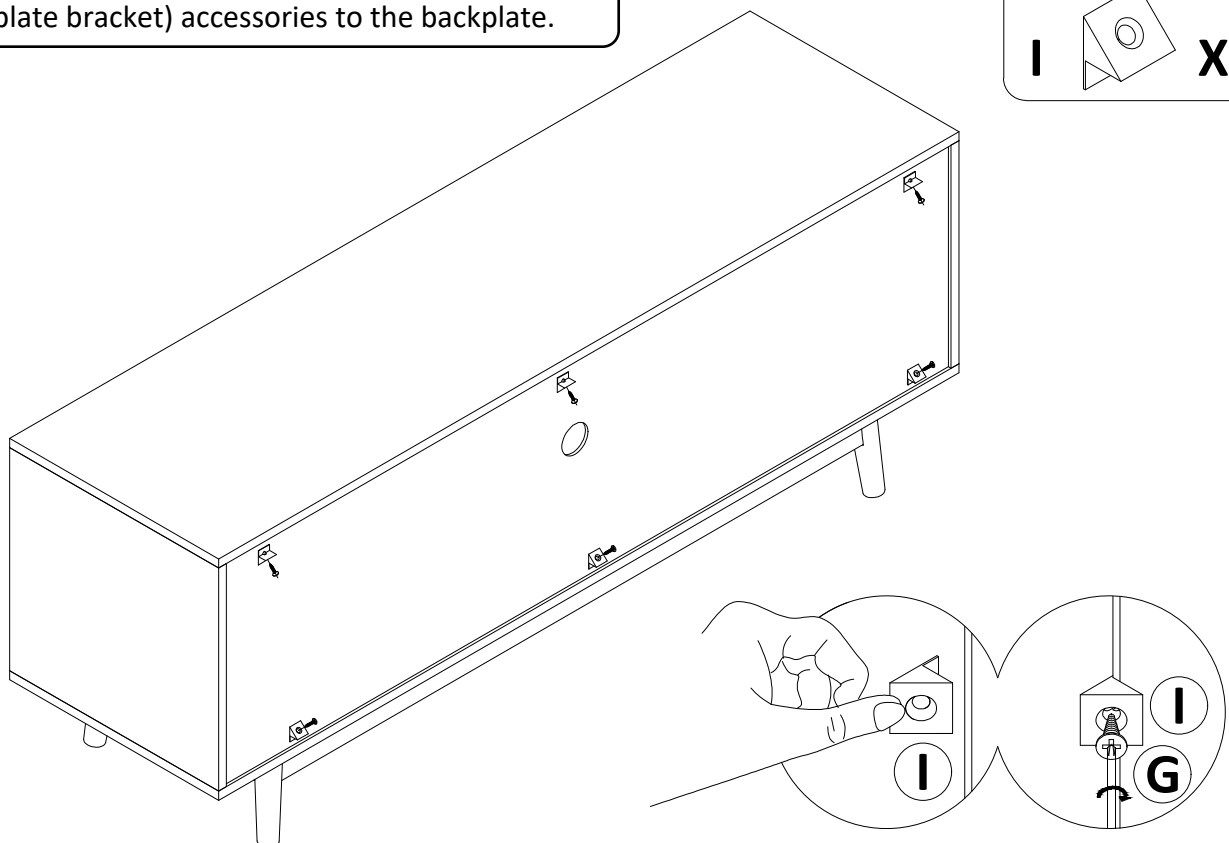

Assembly Completed

