

Assembly Instructions - Please keep for future reference

Instructions d'assemblage -s'il vous plait garder pour référence future

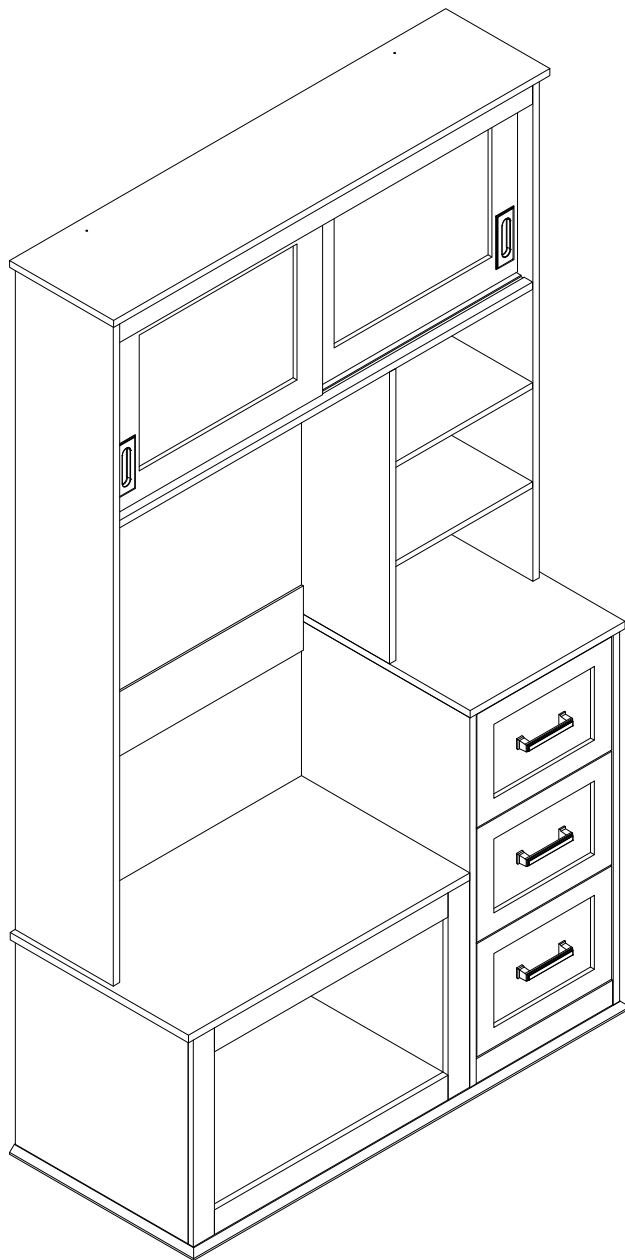

Important-Please read these instructions fully before starting assembly

Important - veuillez lire ces instructions complètement avant de commencer l'assemblage

Safety and Care Advice

Important – Please read these instructions fully before starting assembly

- Check you have all the components and tools listed on the following pages.
- Remove all fittings from the plastic bags and separate them
- Keep children and pets away from the installation area, which may cause choking if small parts are swallowed.
- Make sure you have enough space to layout the parts before

- Do not stand or apply weight to the product during assembly. This may cause damage.
- Assemble the item as close to its final position (in the same room) as possible.
- Assemble on a soft level surface to avoid damage to the unit or floor.
- It's easier for two people to assemble the parts together.



- To reduce the likelihood of damage to your product, make sure your power drill is set to a low torque setting.

Care and maintenance

- Only clean using a damp cloth and mild detergent, do not use bleach or abrasive cleaners.
- Check for loose screws on this unit from time to time.
- This product should not be discarded with household waste. Take to your local authority waste disposal centre.

Handy Hints

- Assemble all parts and bolts loosely during assembly, only once the product is complete should you fully tighten the bolts
- Regularly check and ensure that all bolts and fittings are correctly tightened.

WARNING In order to help prevent overturning – please follow these instructions

To help prevent product toppling over please follow the below steps:-

Use the anti tip stap or wall fixing method provided (if applicable)
Do not allow children to climb or hang on the furniture
Do not open more than one drawer at a time
Do not place heavy items in the top drawers
Do not place heavy items on top of the furniture, unless the furniture has been designed for this purpose

please note that only the anti tip strap is provided.
You will need to provide wall plugs and screws applicable for your wall type

Conseils de sécurité et de soins

Important - veuillez lire ces instructions complètement avant de commencer l'assemblage

- Vérifiez que vous avez tous les composants et outils énumérés sur les pages suivantes.
- Retirez tous les accessoires des sacs en plastique et les séparez
- Gardez les enfants et les animaux de compagnie loin de la zone d'installation, qui peut causer l'étouffement si de petites pièces sont avalées.
- Assurez-vous d'avoir suffisamment d'espace pour mettre en page les pièces avant.
- Ne pas se tenir debout ou appliquer le poids à Le produit pendant l'assemblage. Cela peut causer des dommages.
- Assemblez l'élément le plus près possible de sa position finale (dans la salle de sameroom).
- Assemblez sur un niveau doux Surface pour éviter les dommages À l'unité ou à l'étage.
- Il est plus facile pour deux personnes de se réunir Les parties ensemble.
- Pour réduire la probabilité De dommages à votre produit, Assurez-vous que votre perceuse électrique Est réglé sur un réglage de couple faible.



Entretien et entretien

- Nettoyer uniquement à l'aide d'un détergent doux à linge humide, ne pas utiliser d'eau de javel ou de nettoyeurs abrasifs
- Vérifiez les vis desserrées sur Cette unité de temps en temps.
- Ce produit ne doit pas être jeté avec les ordures ménagères emporter au centre d'élimination des déchets de votre collectivité locale

Conseils pratiques

- Assemblez toutes les pièces et boltsloosely pendant l'assemblée, onlyonce que le produit est completeshould vous serrez entièrement les boulons
- Vérifier et assurer régulièrement Que tous les boulons et raccords sont Correctement serré.

Avertissement Afin de prévenir le renversement Veuillez suivre ces instructions

Pour aider à prévenir le renversement du produit, veuillez suivre les étapes suivantes :-

Utilisez la méthode anti-tip stap ou de fixation murale fournie (le cas échéant)
Ne laissez pas les enfants grimper ou accrocher aux meubles
N'ouvrez pas plus d'un tiroir à la fois
Ne placez pas d'objets lourds dans les tiroirs supérieurs
Ne placez pas d'objets lourds sur le dessus des meubles, sauf si les meubles ont été Conçu à cet effet

Veuillez noter que seule la courroie anti-pointe est fournie.

Vous devrez fournir des bouchons muraux et des vis applicables pour votre type de mur

Using Camlocks

Step 1

Connect the male camlock as directed in the assembly instructions using a screwdriver.

1 DO NOT OVER TIGHTEN.

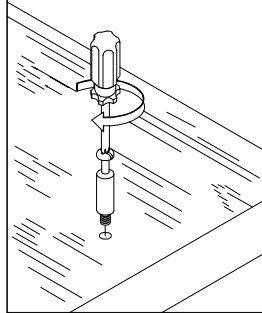

Step 2

Push the male camlock into the entry hole.

2

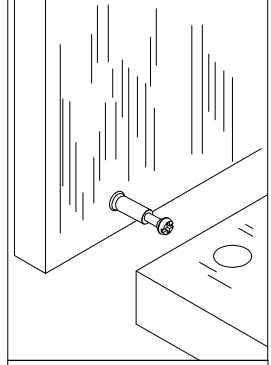

Step 3

Insert the female camlock as shown in the instruction.

Note: ensure that the arrow on the top of the camlock points towards the entry hole for the male camlock.

3

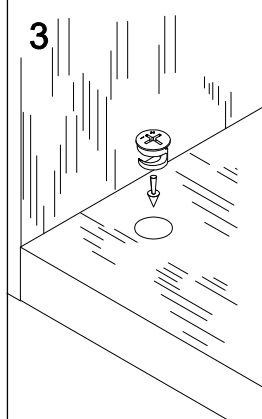

Step 4

Turn the female camlock clockwise with a screwdriver.

You should feel a click when the camlock is locked in place.

The joint is now secure.

4

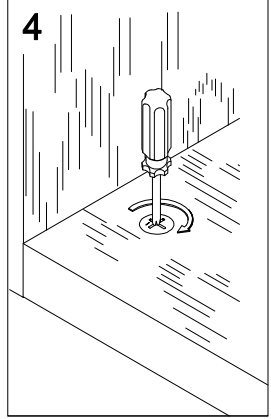

Utilisation de Camlocks

1

Connectez le mâle Camlock tel que dicté dans Les instructions de montage Utiliser un driver screwdriver.

1

Ne pas trop serrer.
NE PAS SERRER EXCESSIVEMENT.

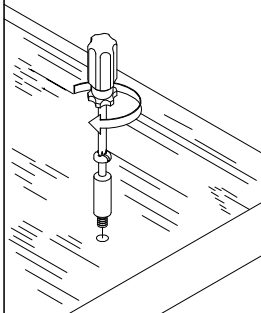

2

Poussez le camlock mâle Dans le trou d'entrée.

2

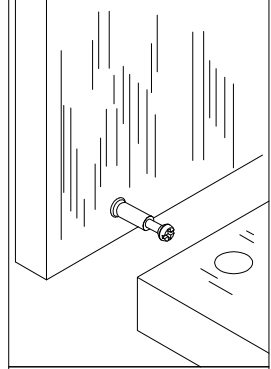

3

Insérer le femelle Camlock comme indiqué dans le Instruction.

Note: assurez-vous que le Flèche sur le haut de la Camlock pointe vers Le trou d'entrée pour la Mâle camlock.

3

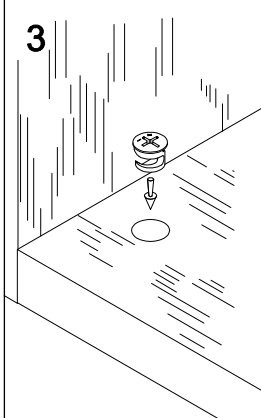

4

Tournez la femelle camlock Dans le sens horaire avec un Tournevis.

Vous devriez sentir un clic Lorsque le camlock est Verrouillé en place.

Le joint est maintenant sécurisé.

4

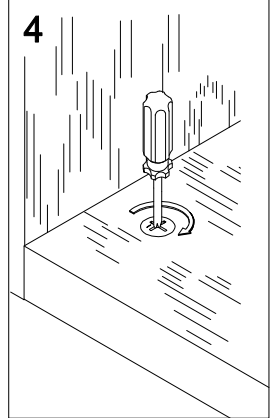

Assembly Instructions/Instructions de montage

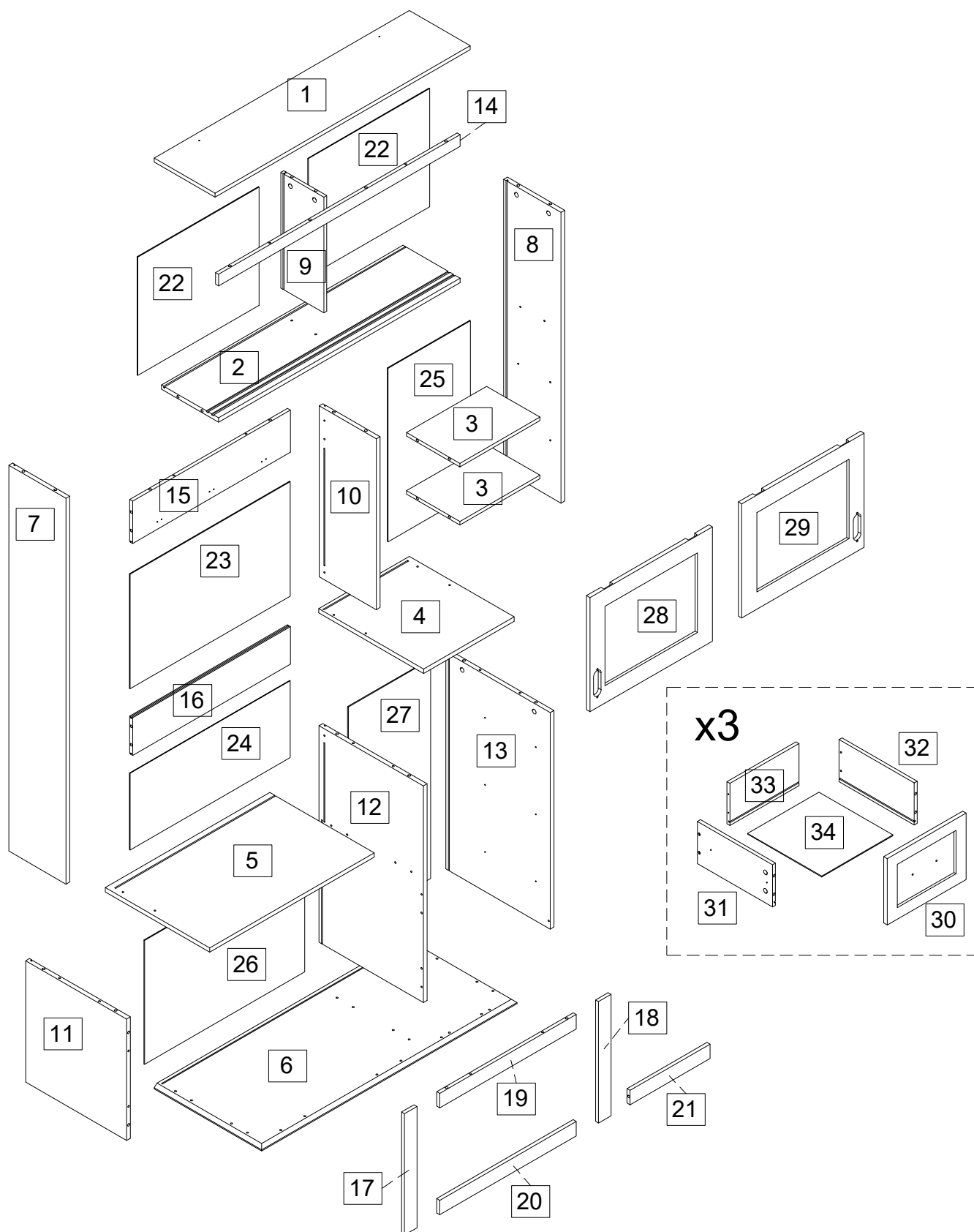





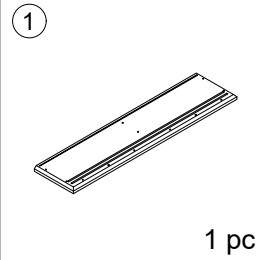
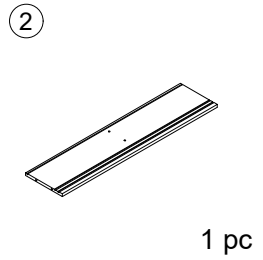
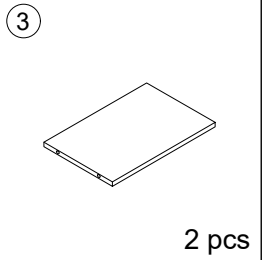
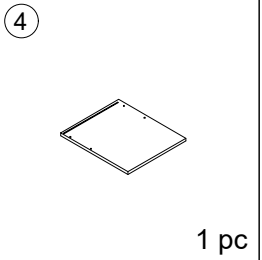
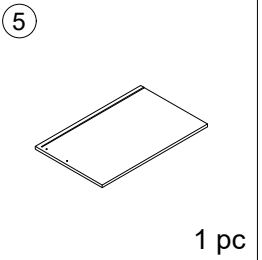
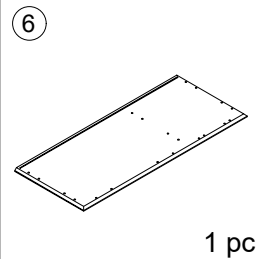
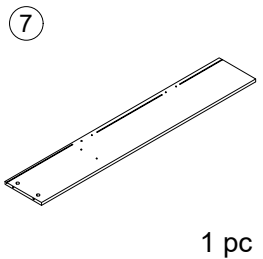
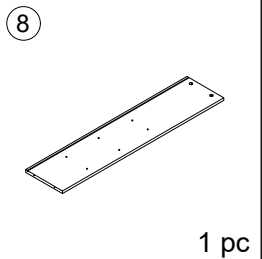
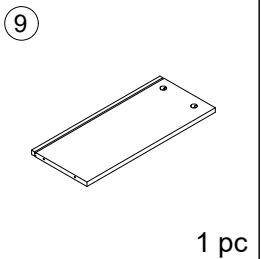
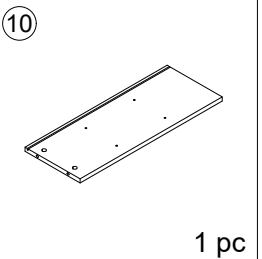
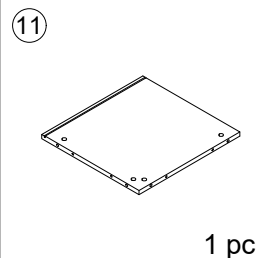
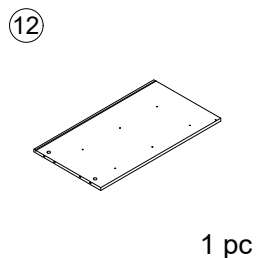
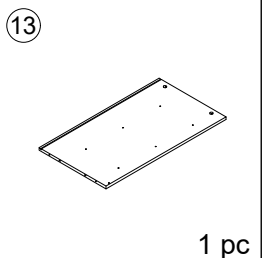
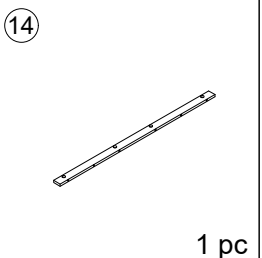
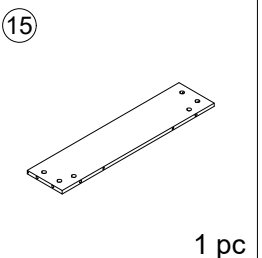
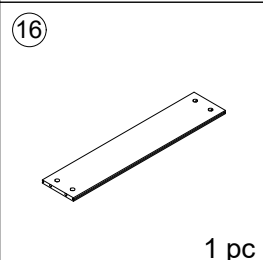
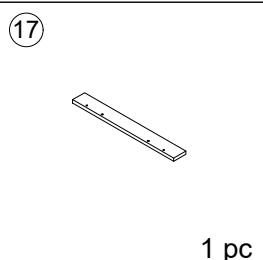
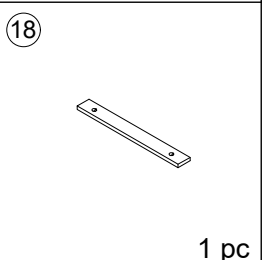
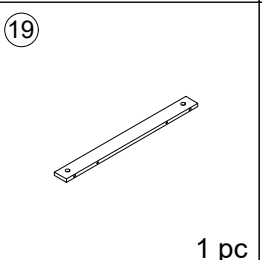
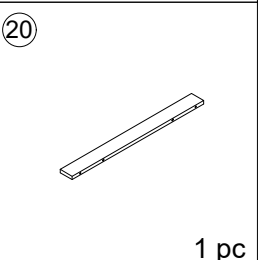
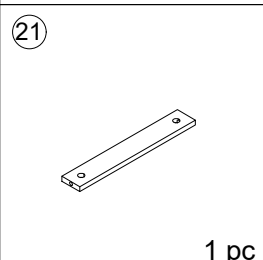
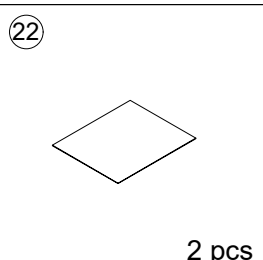
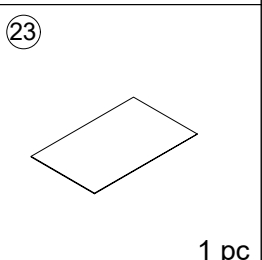
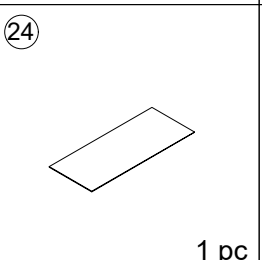
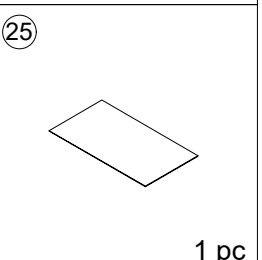
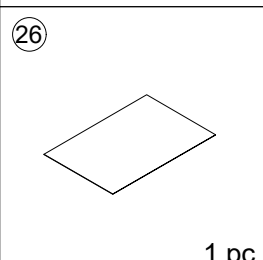
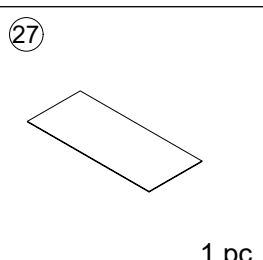
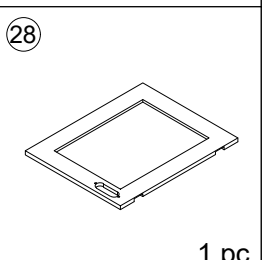
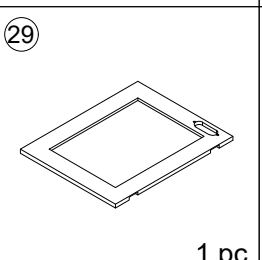
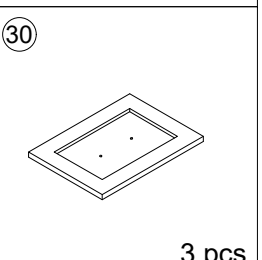
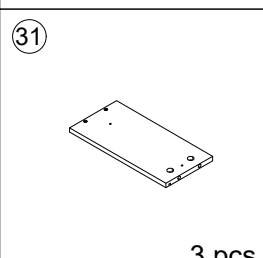
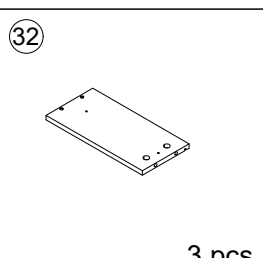
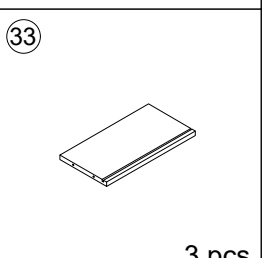
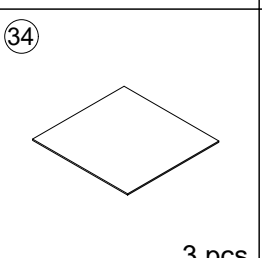







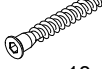

Part List / Liste des pièces

Hardware list/Liste du matériel: N724P264676

 <p>1 pc</p>	 <p>1 pc</p>	 <p>2 pcs</p>	 <p>1 pc</p>	 <p>1 pc</p>
 <p>1 pc</p>	 <p>1 pc</p>	 <p>1 pc</p>	 <p>1 pc</p>	 <p>1 pc</p>
 <p>1 pc</p>	 <p>1 pc</p>	 <p>1 pc</p>	 <p>1 pc</p>	 <p>1 pc</p>
 <p>1 pc</p>	 <p>1 pc</p>	 <p>1 pc</p>	 <p>1 pc</p>	 <p>1 pc</p>
 <p>1 pc</p>	 <p>2 pcs</p>	 <p>1 pc</p>	 <p>1 pc</p>	 <p>1 pc</p>
 <p>1 pc</p>	 <p>1 pc</p>	 <p>1 pc</p>	 <p>1 pc</p>	 <p>3 pcs</p>
 <p>3 pcs</p>	 <p>3 pcs</p>	 <p>3 pcs</p>	 <p>3 pcs</p>	

Hardware list /Liste du matériel

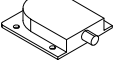
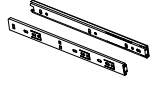
<p>A </p> <p>Male Camlock x 62</p>	<p>B </p> <p>Female Camlock x 62 Femelle Camlock</p>	<p>C </p> <p>Dowel x 28 Le goujon</p>
<p>D </p> <p>Hex Key M3 x 1 Clé hexagonale M4</p>	<p>E </p> <p>3.5*14mm Screw x 62 3.5*14mm vis</p>	<p>F </p> <p>5*38mm Screw x 18 5*38mm vis</p>
<p>G </p> <p>4*35mm Screw x 12 4*35mm vis</p>	<p>H </p> <p>Handle x 3 Poignée</p>	<p>I </p> <p>4*8mm Screw x 10 4*8mm vis</p>
<p>J </p> <p>Back Panel Stiffener x 24 Panneau arrière raidisseur</p>	<p>K </p> <p>Ø20 Sticker x 40 Ø20 autocollant</p>	<p>L </p> <p>Wall Fixing Pack x 2 Paquet de fixation murale</p>
<p>M </p> <p>Handle x 2 Poignée</p>	<p>N </p> <p>Ø30 Sticker x 6 Ø30 autocollant</p>	<p>O </p> <p>Hook x 3</p>
<p>P </p> <p>Pulley x 4</p>	<p>Q </p> <p>x 4</p>	<p>R </p> <p>Drawer slider 12" x 3 Tiroir slider 12"</p>

Assembly Tools Required (Not Included)
Outils d'assemblage requis (Non inclus)

Assembly Instructions /instructions de montage

Step 3

Étape 3

B



B x 6

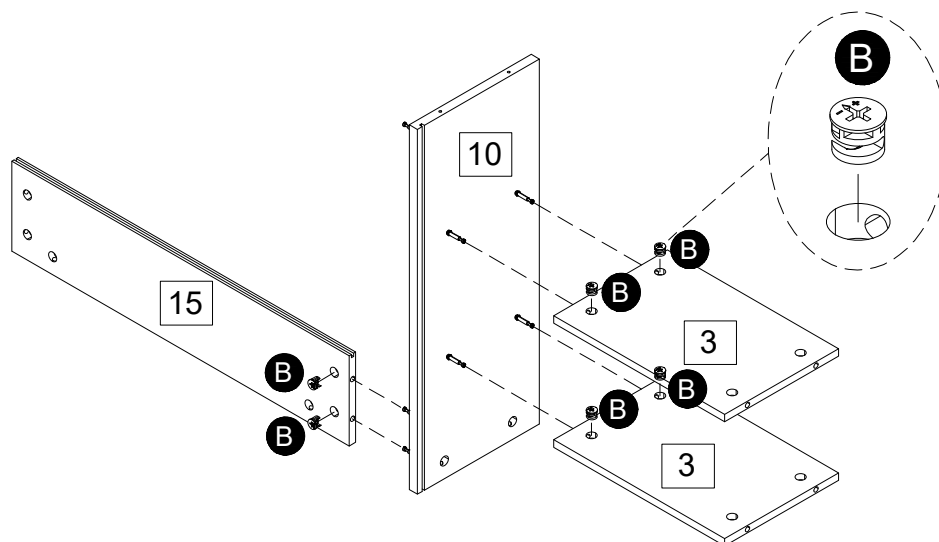

"Need to rotate and tighten B"

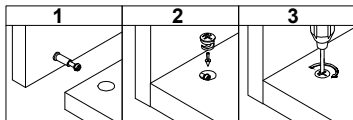

Step 4

Étape 4

B



B x 4

C



C x 2

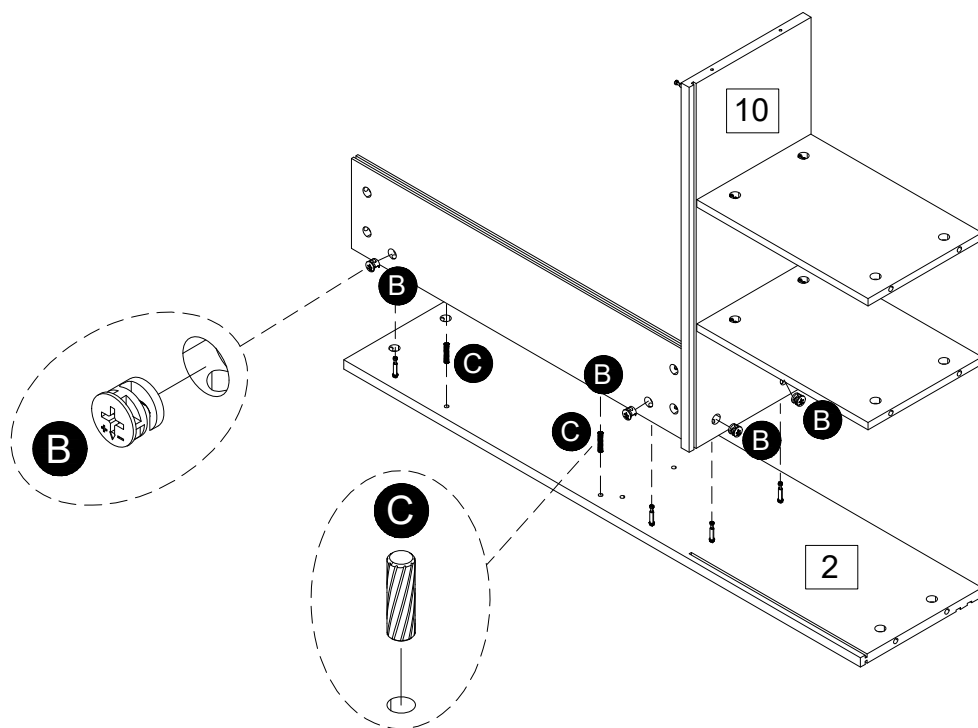

"Need to rotate and tighten B"

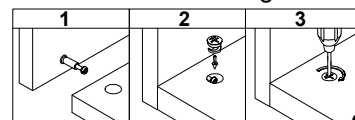

Assembly Instructions /instructions de montage

Step 5

Étape 5

A



A x 6

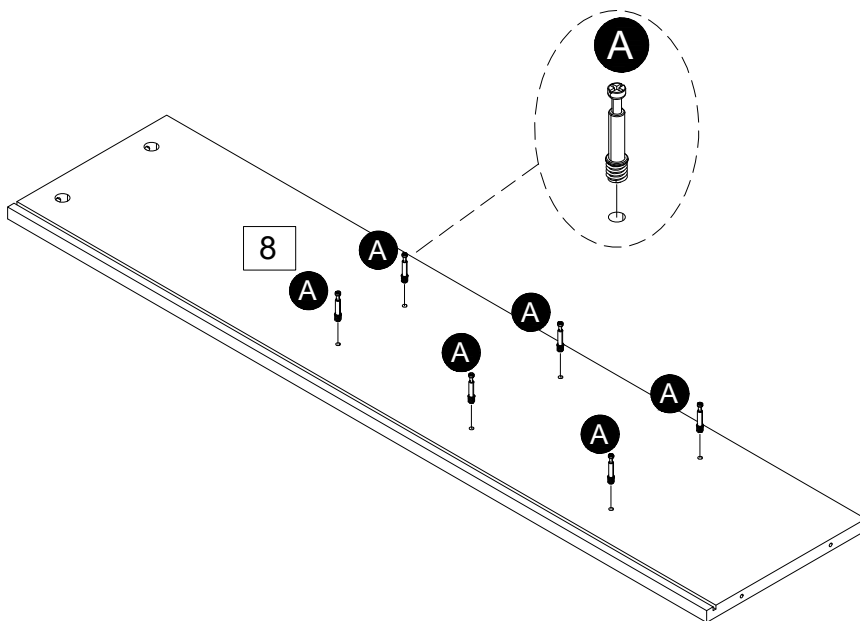

Step 6

Étape 6

"Need to rotate and tighten B"

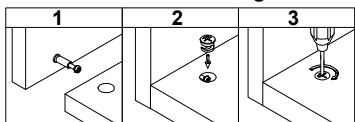

B



B x 6

F

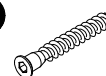

F x 2

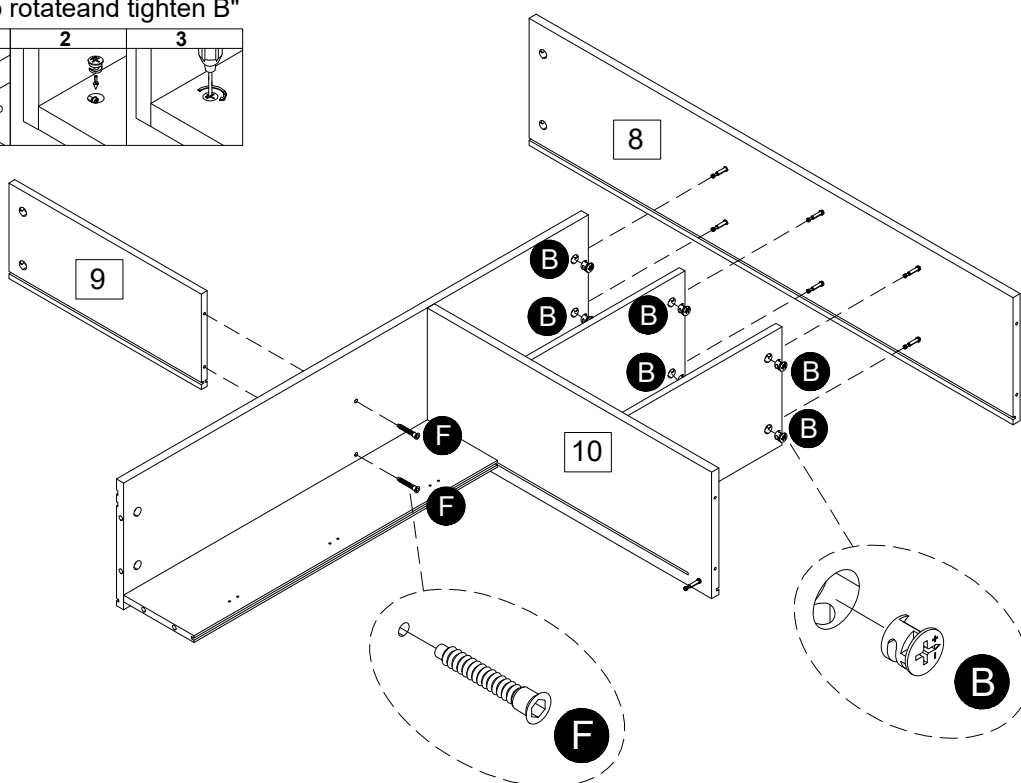

Assembly Instructions /instructions de montage

Step 7

Étape 7

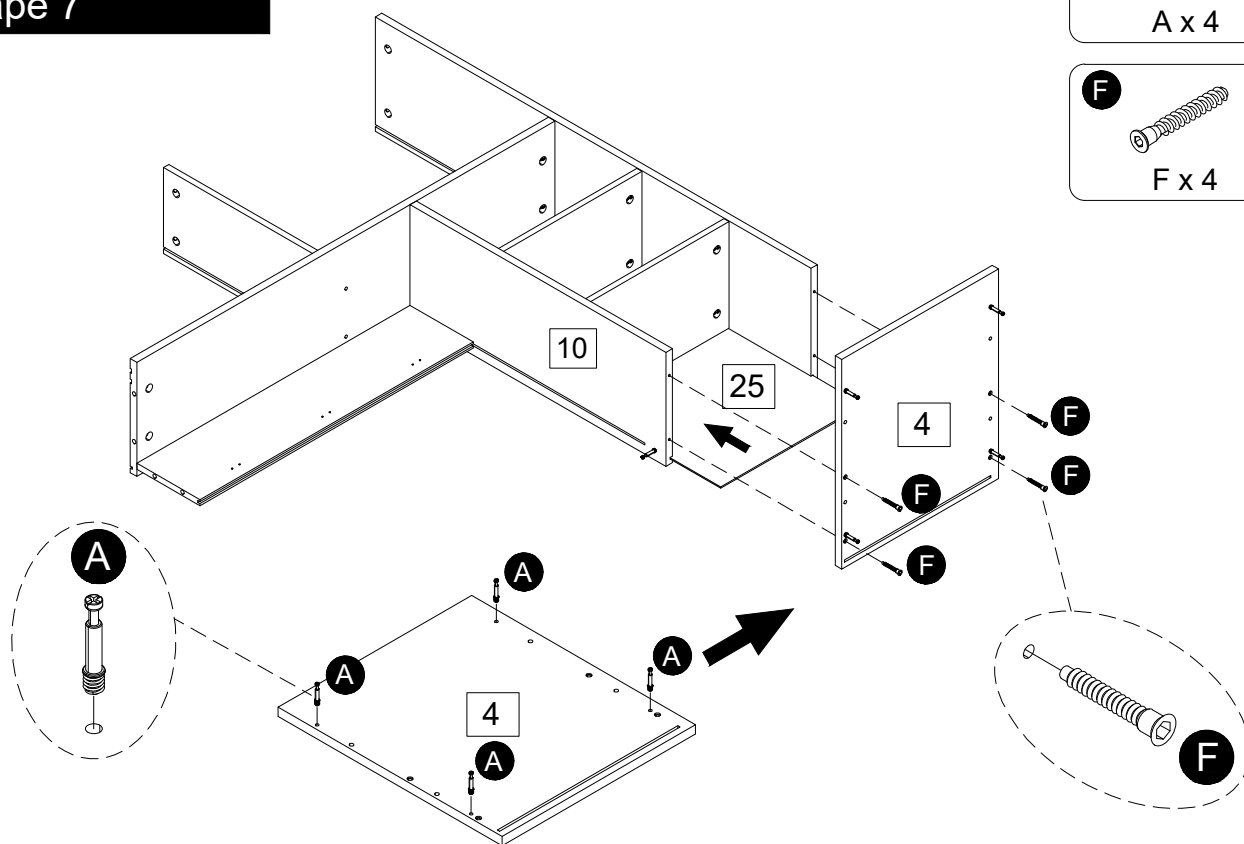

A
A x 4

F
F x 4

Step 8

Étape 8

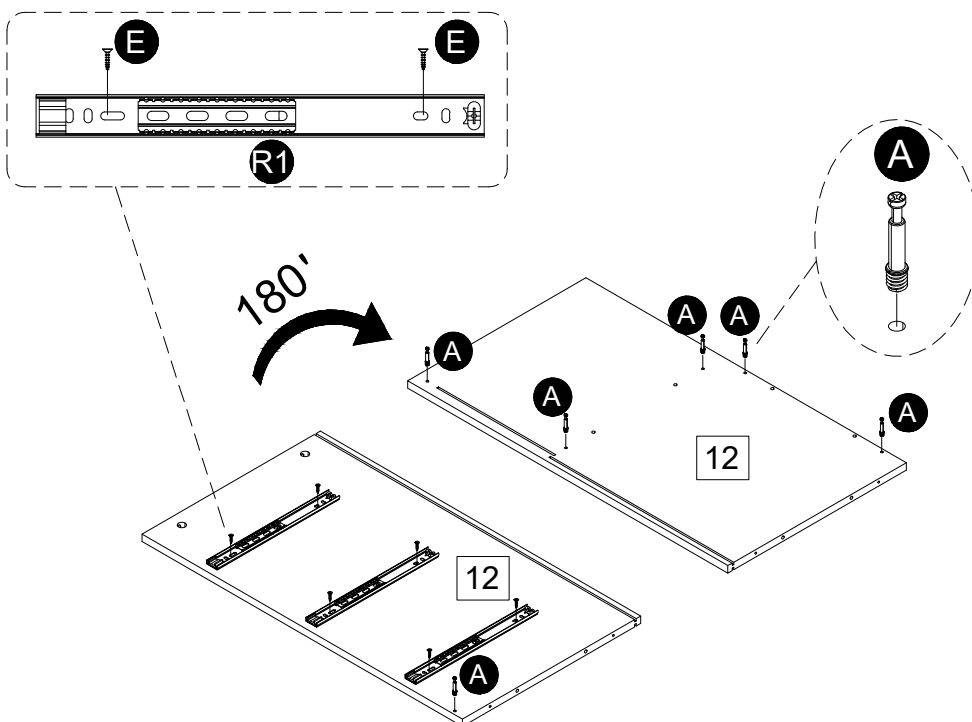

A
A x 6

R1-Ball Bearing Slide
R1 x 3

E
E x 6

Assembly Instructions /instructions de montage

Step 9

Étape 9

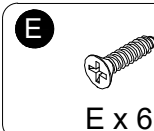
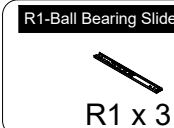
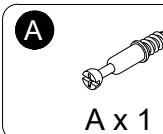
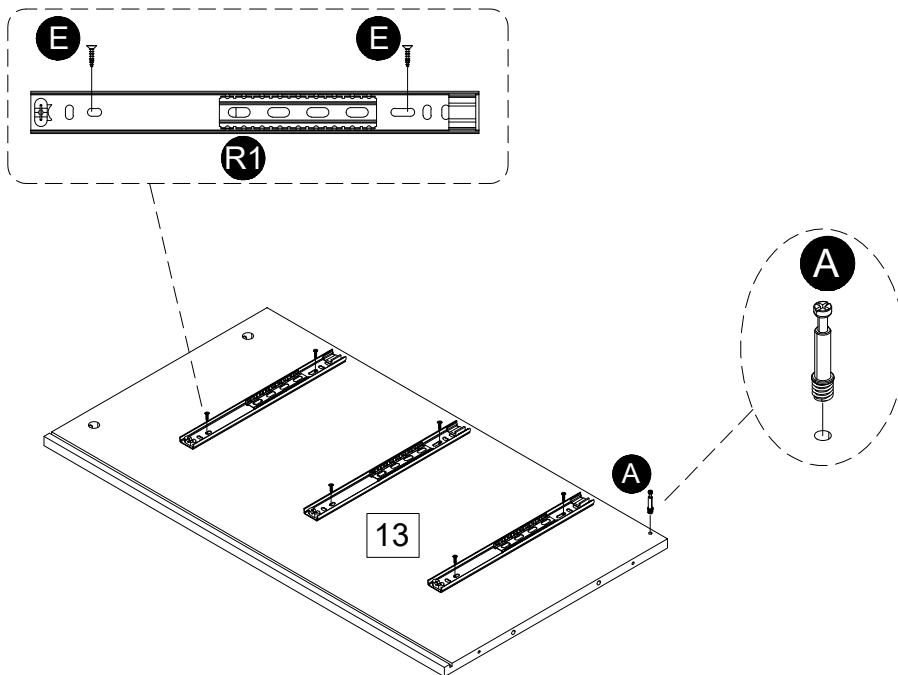

Step 10

Étape 10

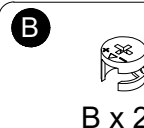
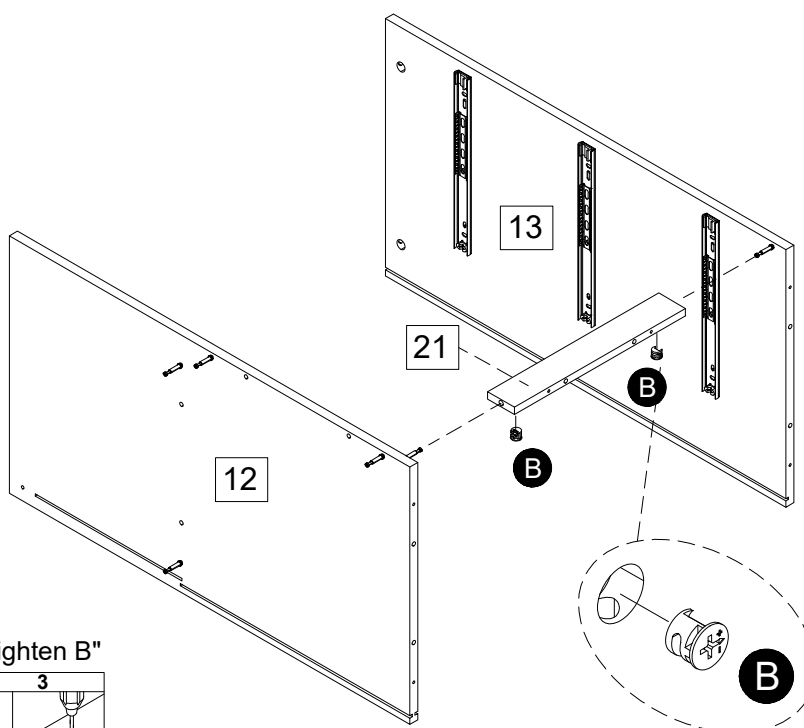

"Need to rotate and tighten B"

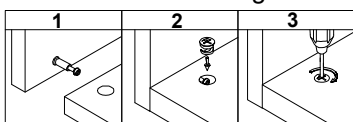

Assembly Instructions /instructions de montage

Step 11

Étape 11

"Need to rotate and tighten B"

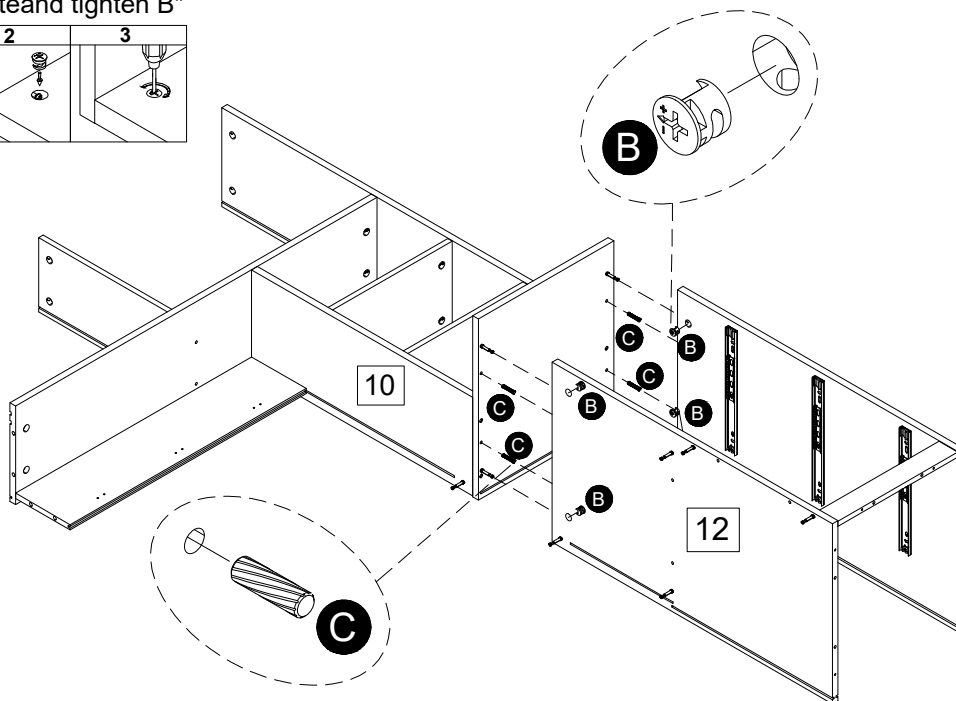
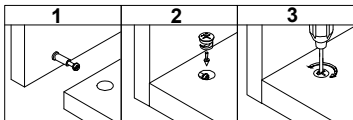

B



B x 4

C



C x 4

Step 12

Étape 12

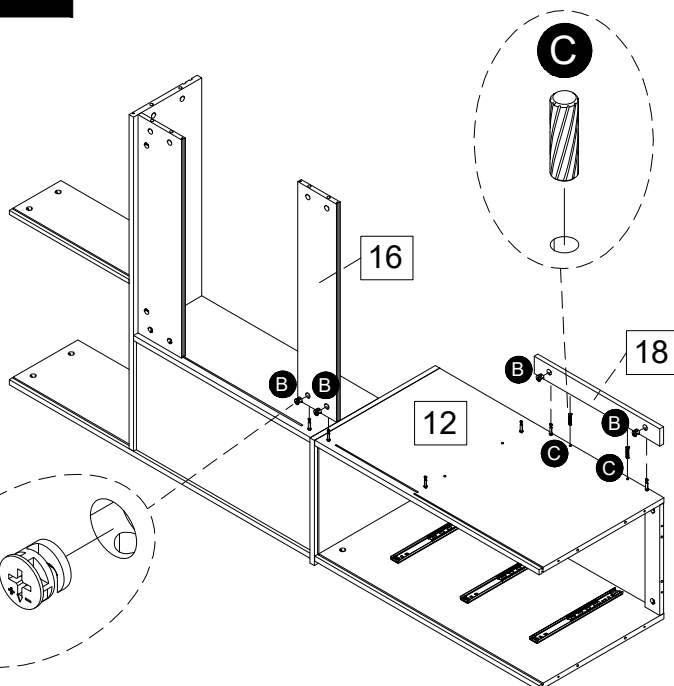

B



B x 4

C



C x 2

"Need to rotate and tighten B"

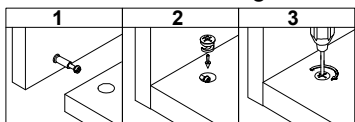

Assembly Instructions /instructions de montage

Step 13

Étape 13

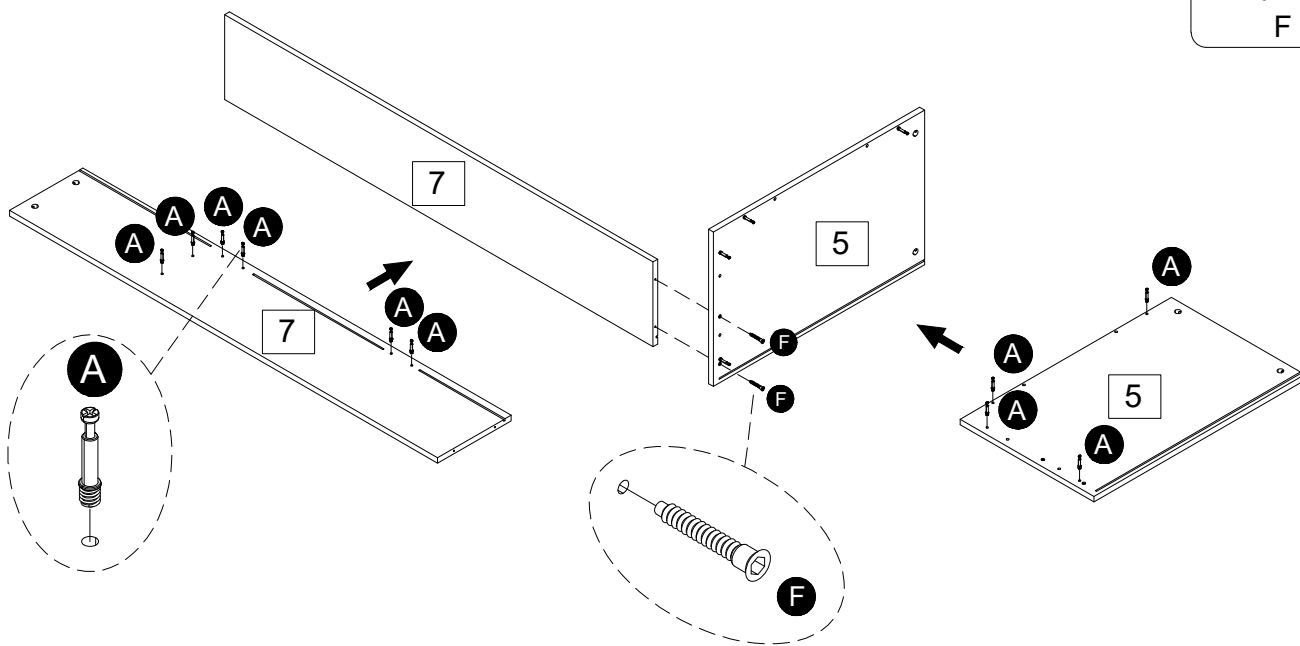
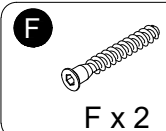
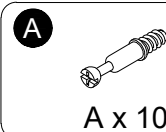

Step 14

Étape 14

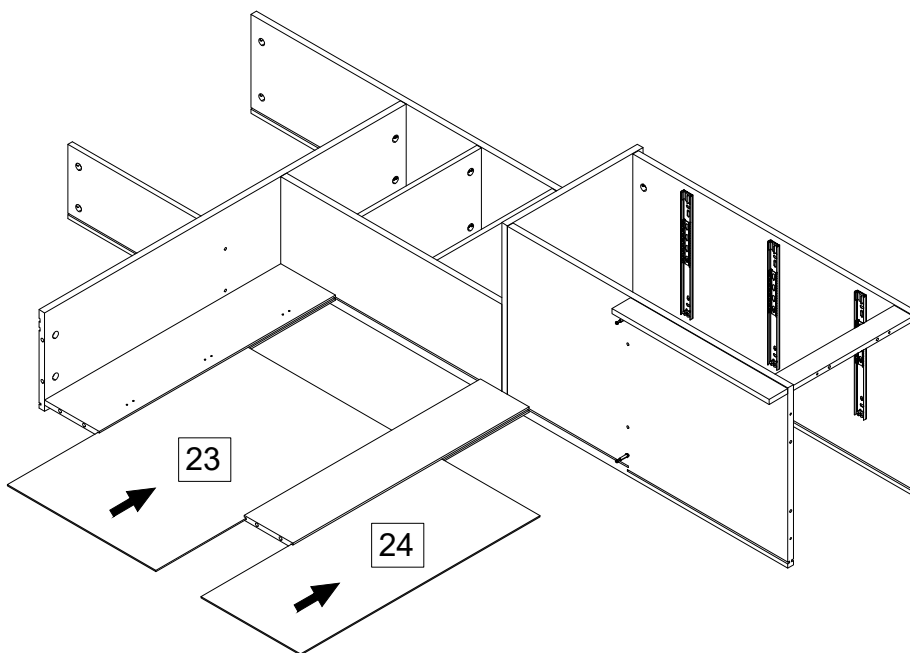

Assembly Instructions /instructions de montage

Step 15

Étape 15

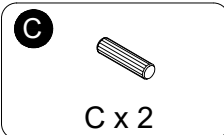
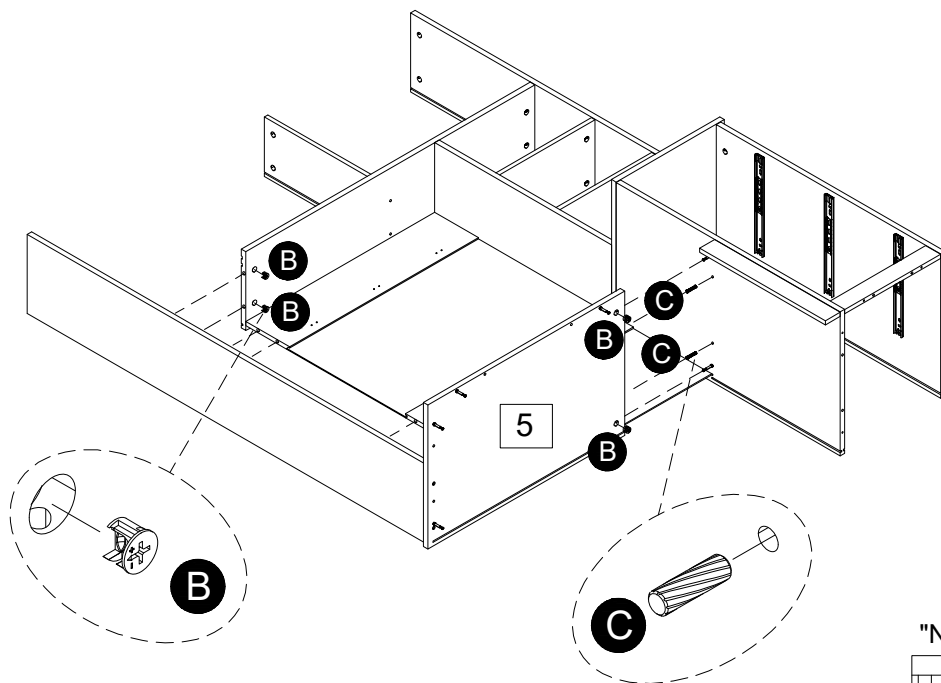

"Need to rotate and tighten B"

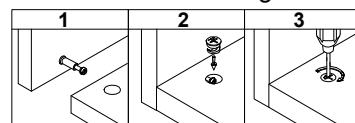

Step 16

Étape 16

"Need to rotate and tighten B"

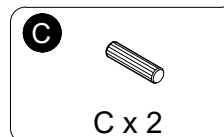
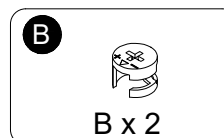
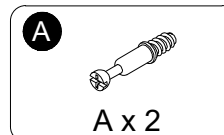
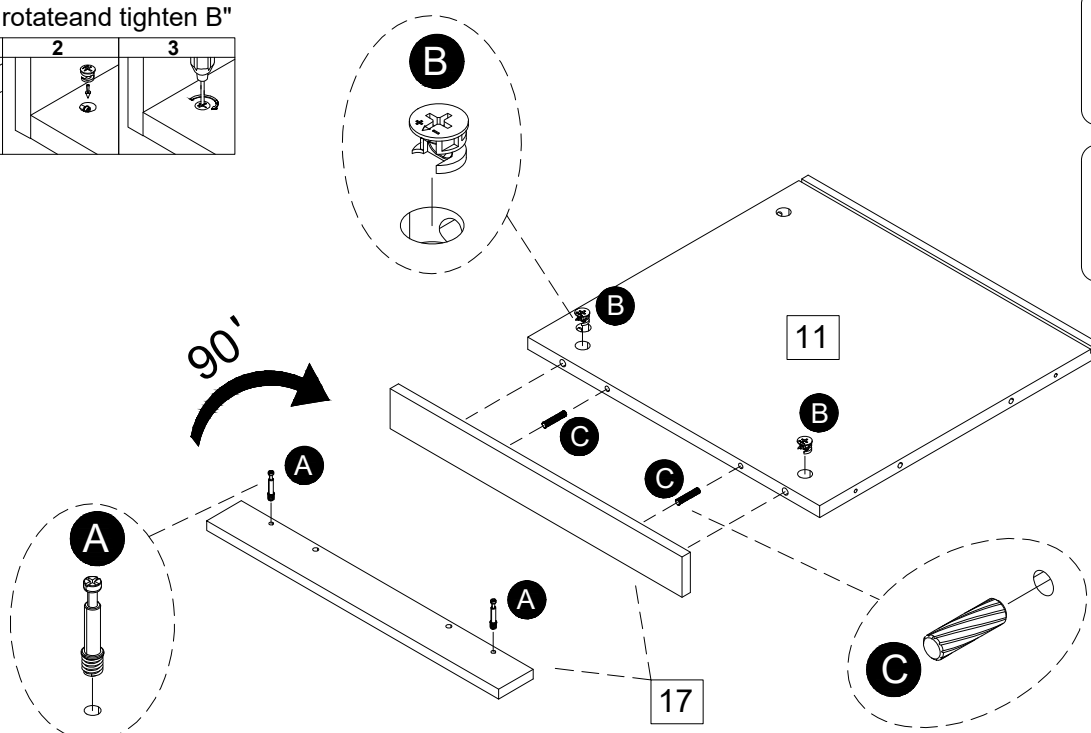
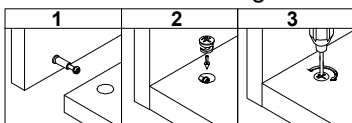

Assembly Instructions /instructions de montage

Step 17

Étape 17

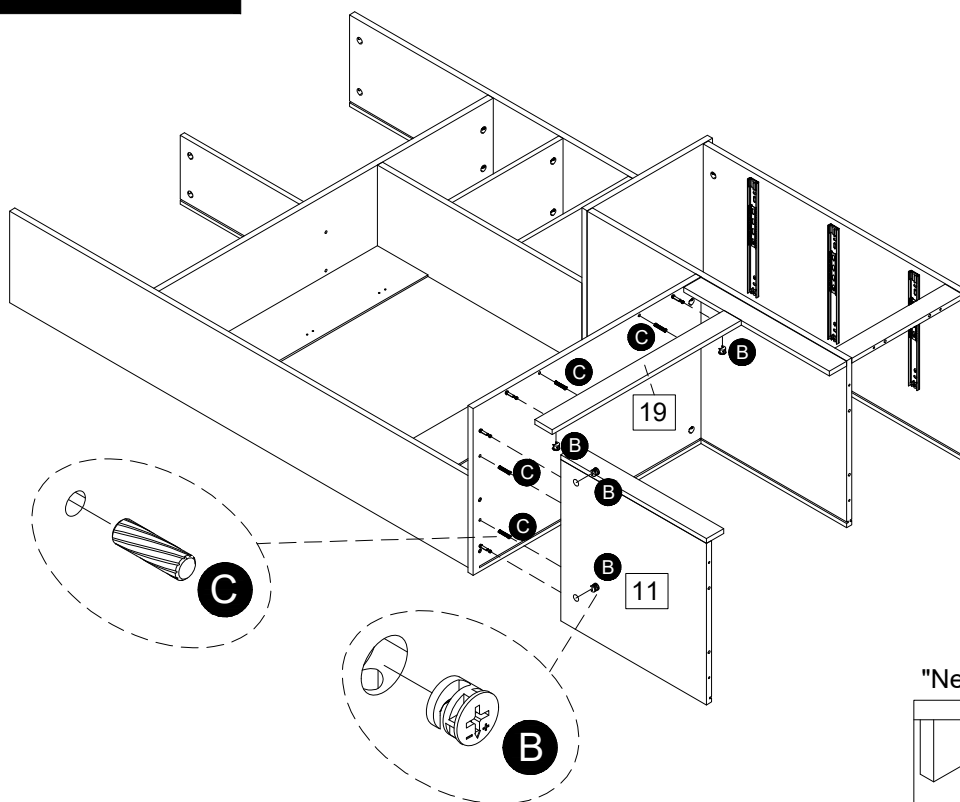

Step 18

Étape 18

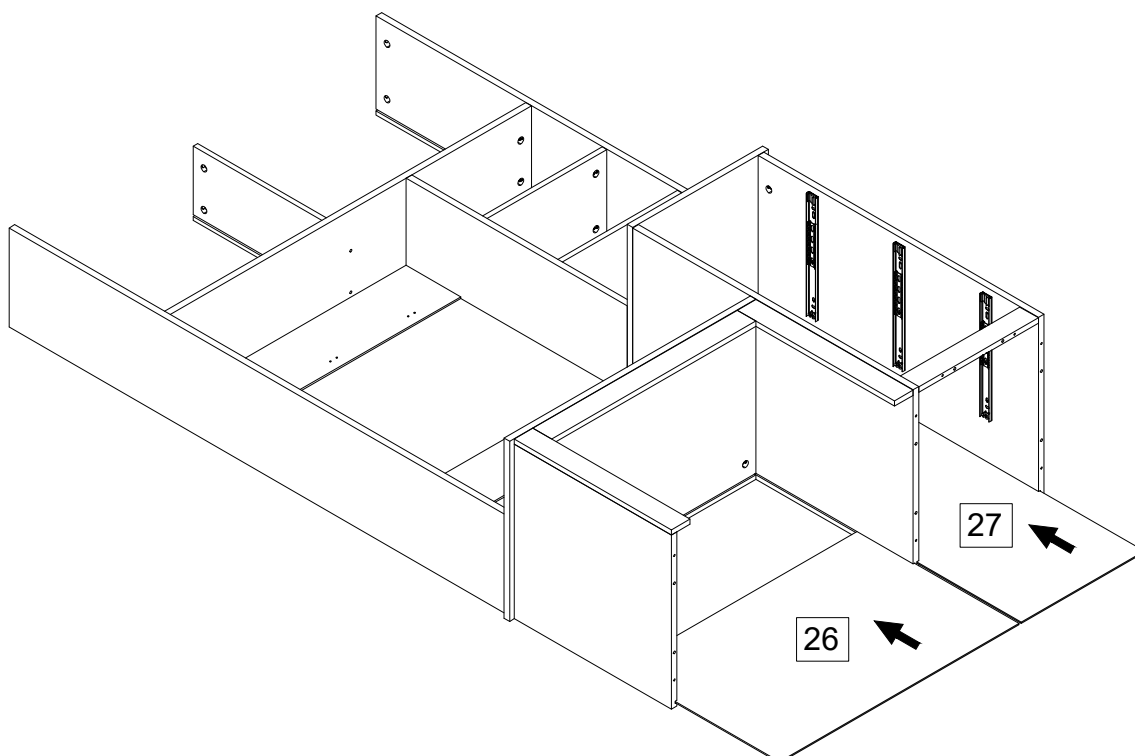

Assembly Instructions /instructions de montage

Step 19

Étape 19

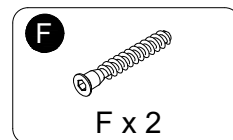
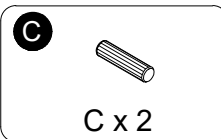
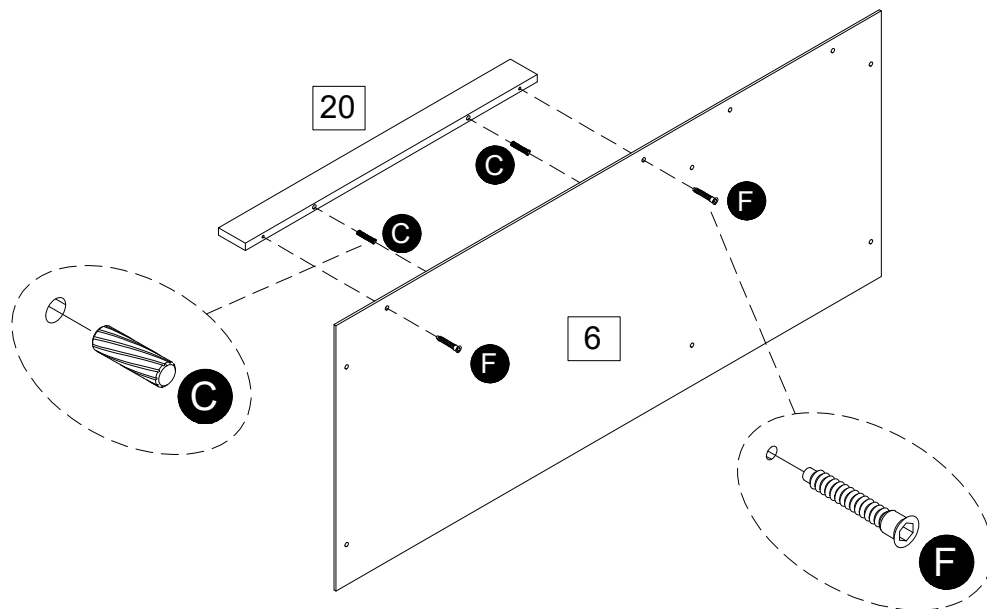

Step 20

Étape 20

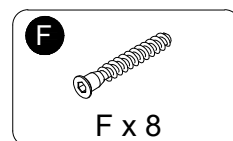
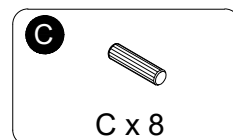
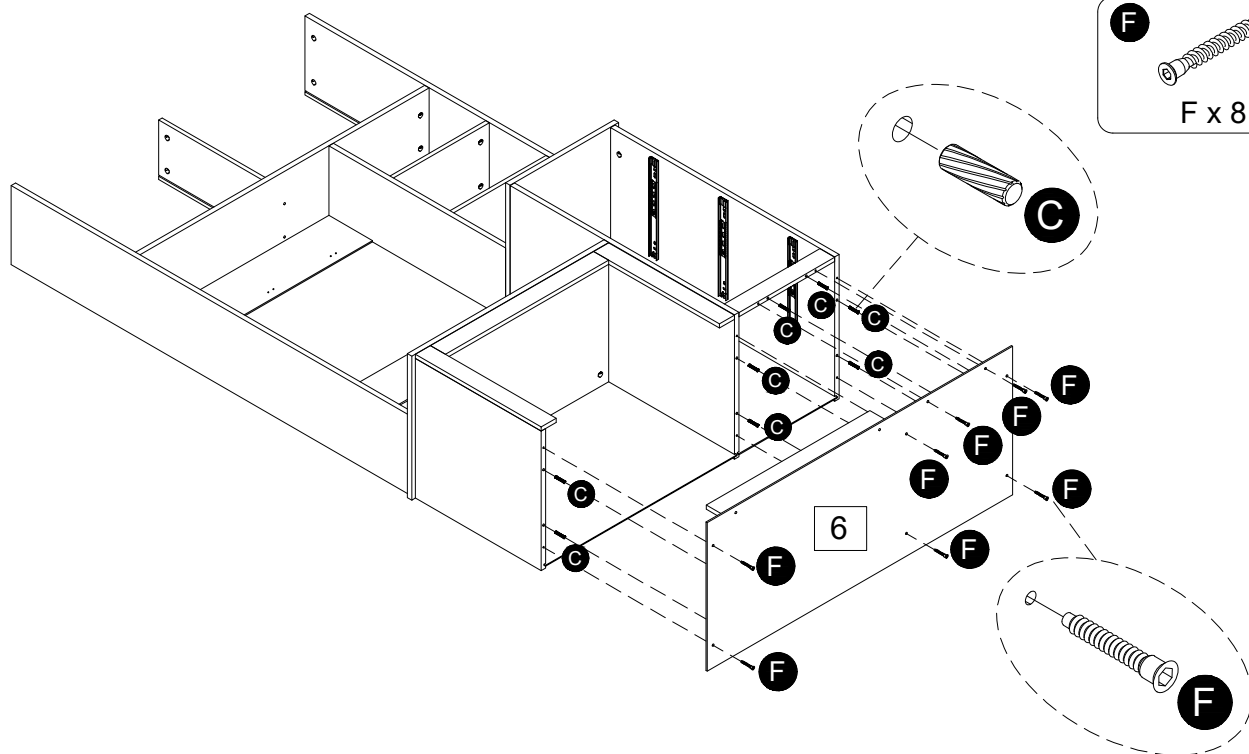

Assembly Instructions /instructions de montage

Step 21

Étape 21

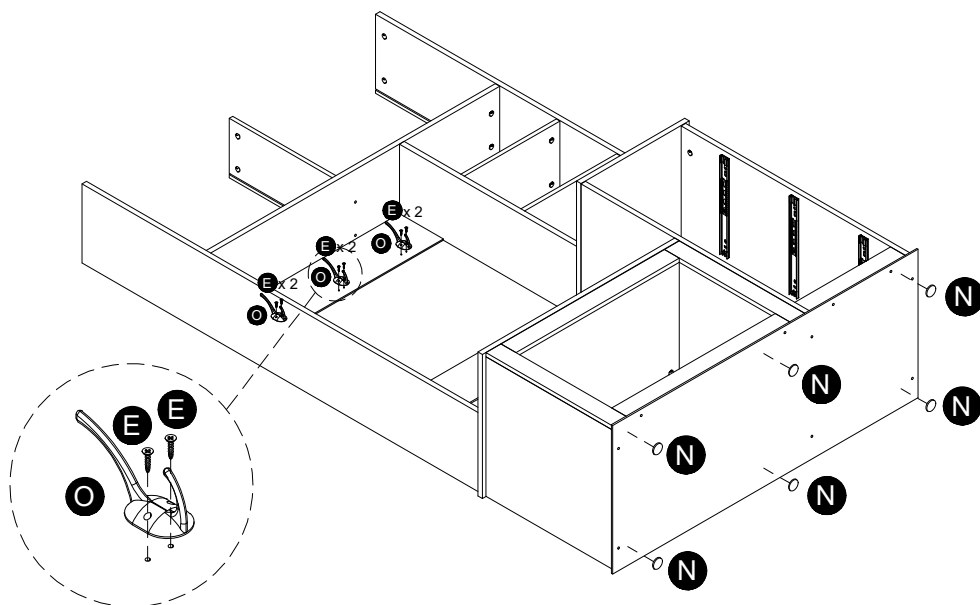

E



E x 6

O



O x 3

N



N x 6

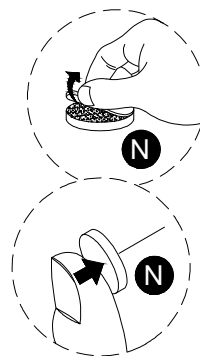

Step 22

Étape 22

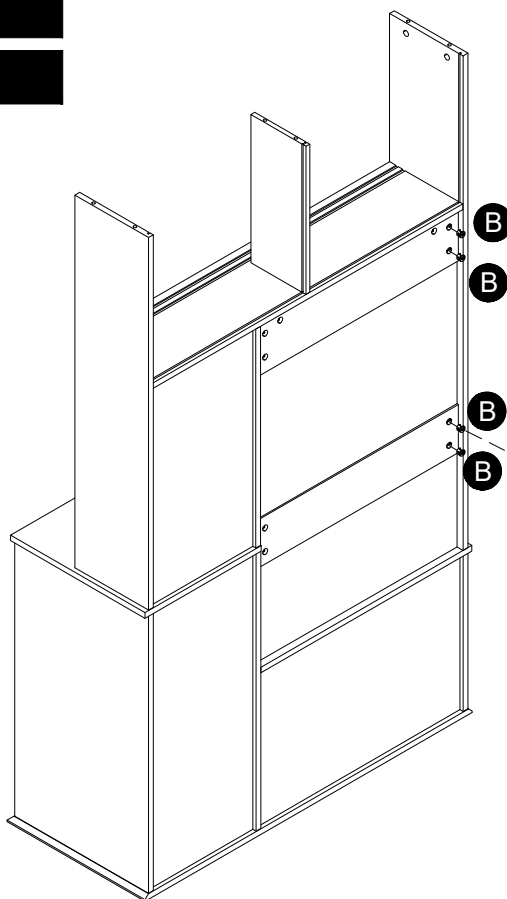

B



B x 4

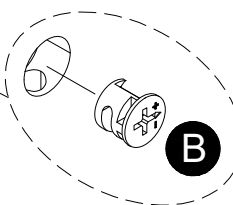

"Need to rotate and tighten B"

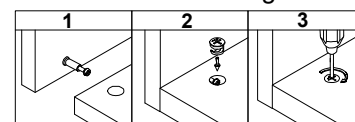

Assembly Instructions /instructions de montage

Step 23

Étape 23

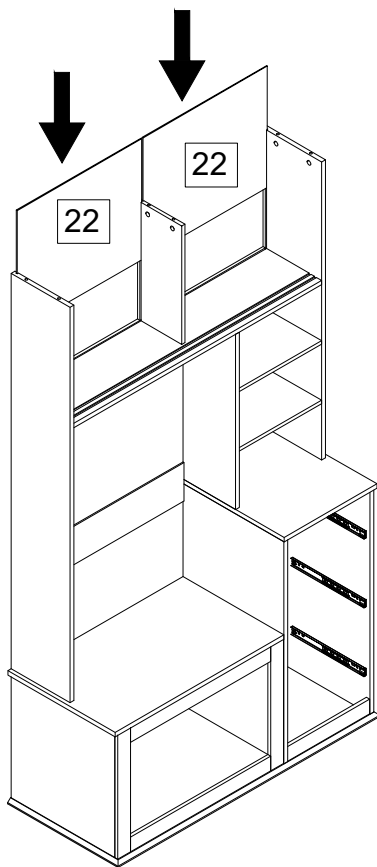

Step 24

Étape 24

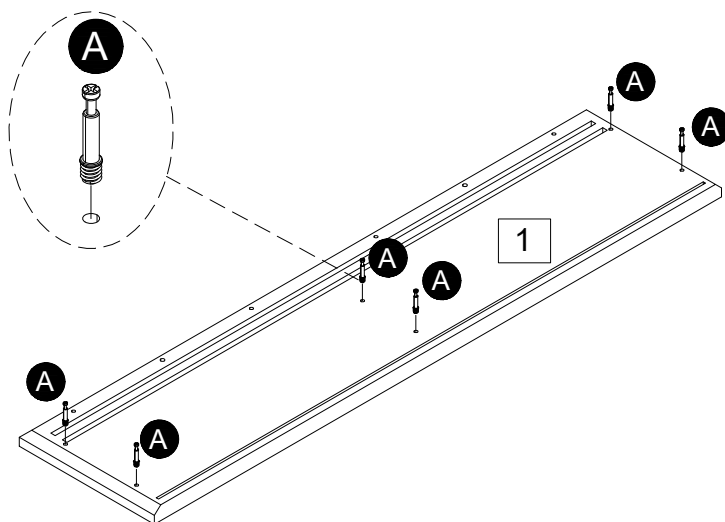
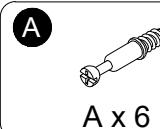

Assembly Instructions /instructions de montage

Step 25

Étape 25

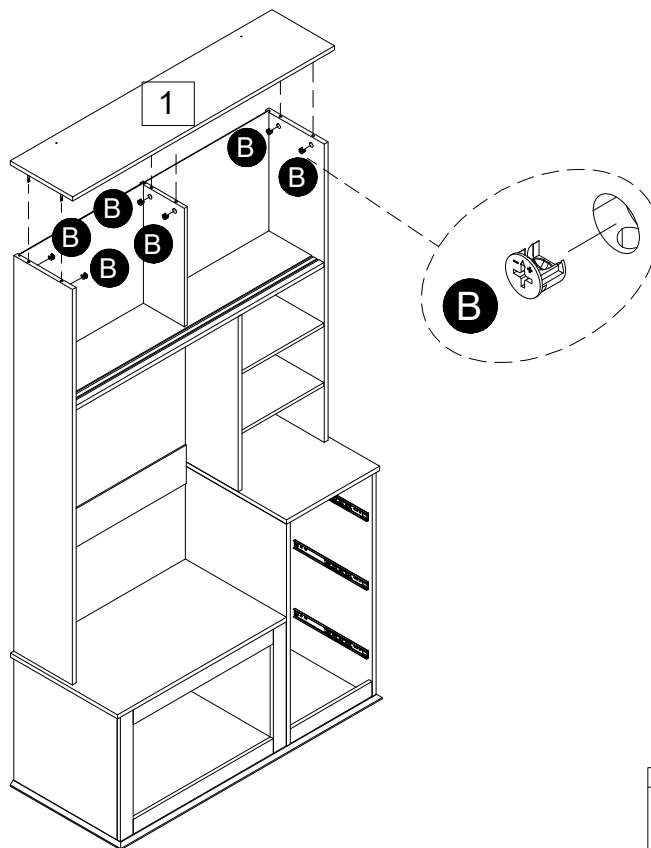

B

 B x 6

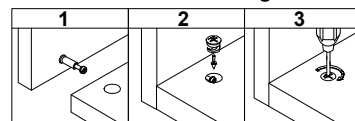
"Need to rotate and tighten B"

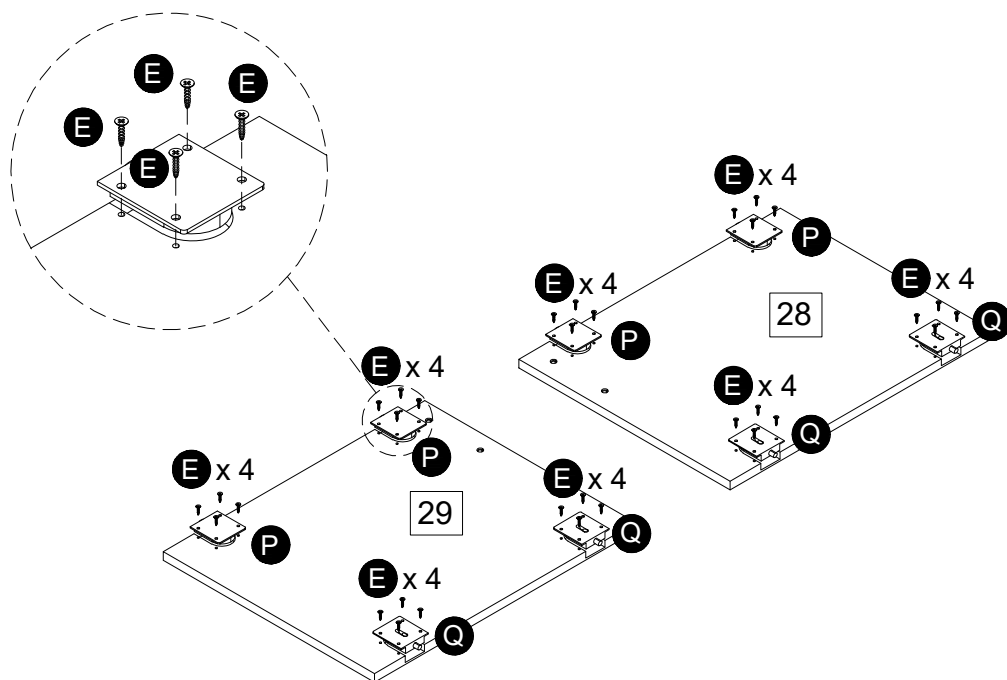

Step 26

Étape 26

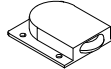

E

 E x 32

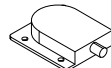
P

 P x 4

Q

 Q x 4

Assembly Instructions /instructions de montage

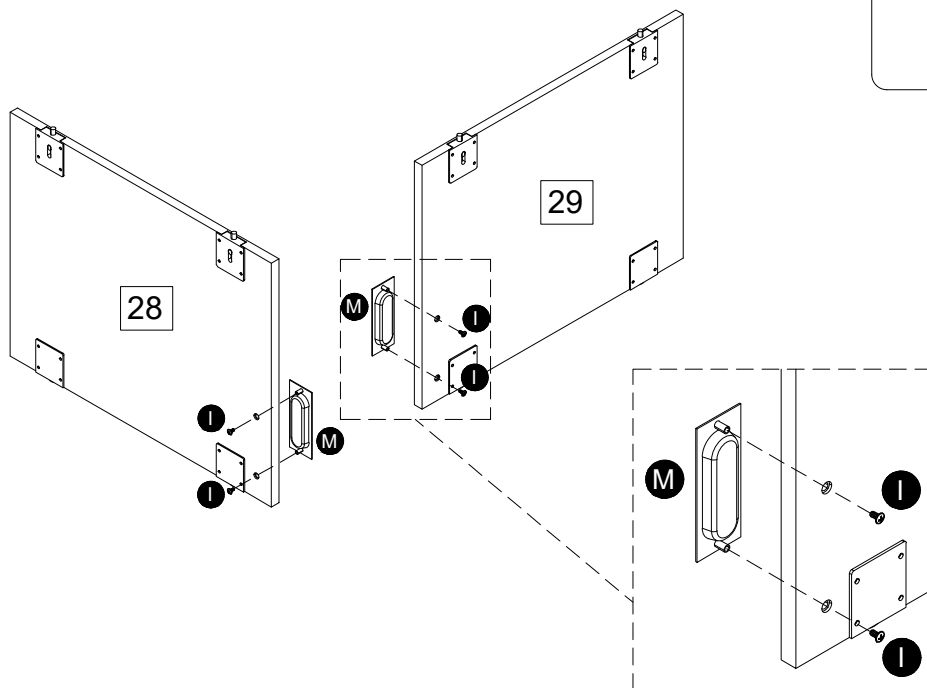
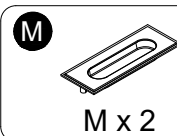
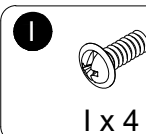
Step 27

Étape 27



Step 28

Étape 28

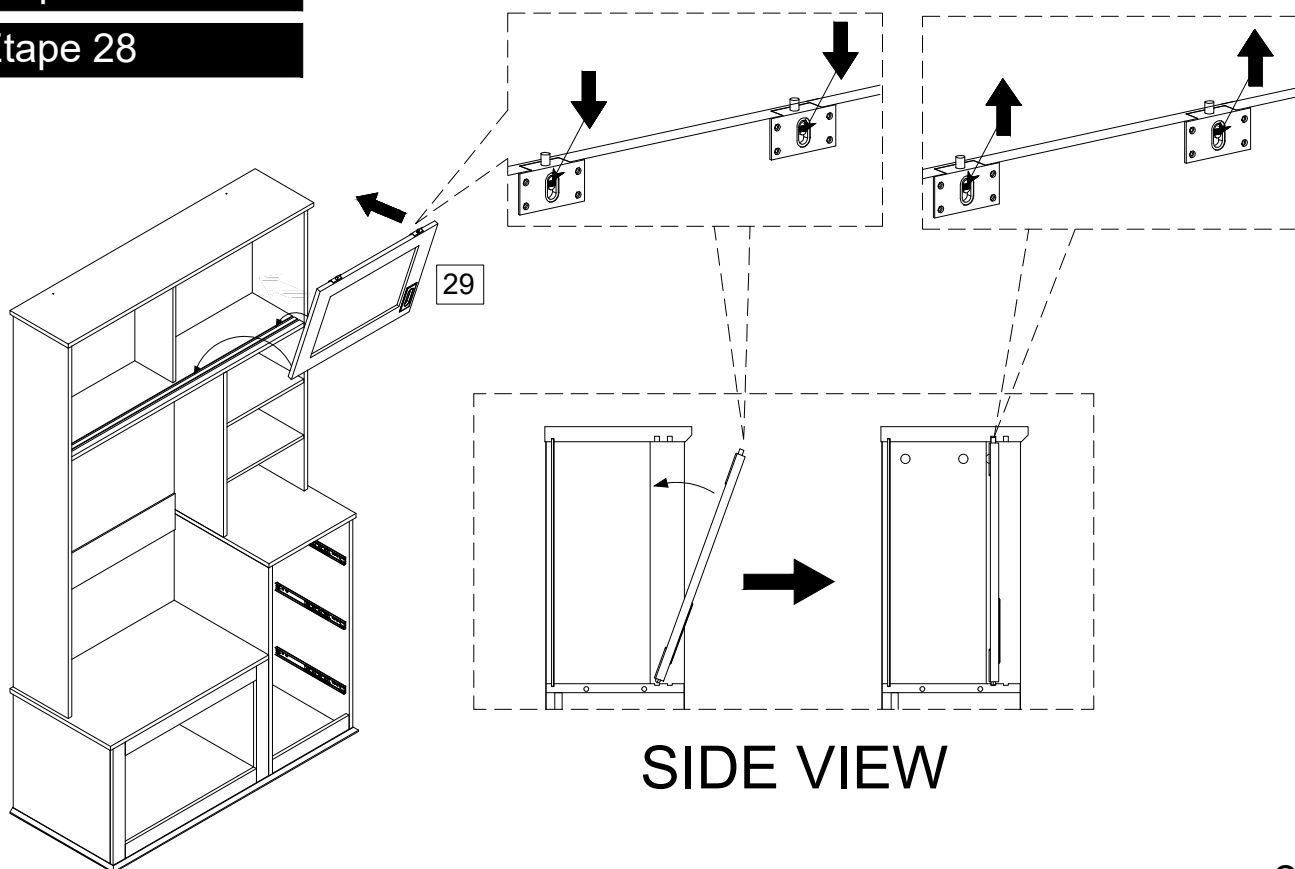

Assembly Instructions /instructions de montage

Step 29

Étape 29

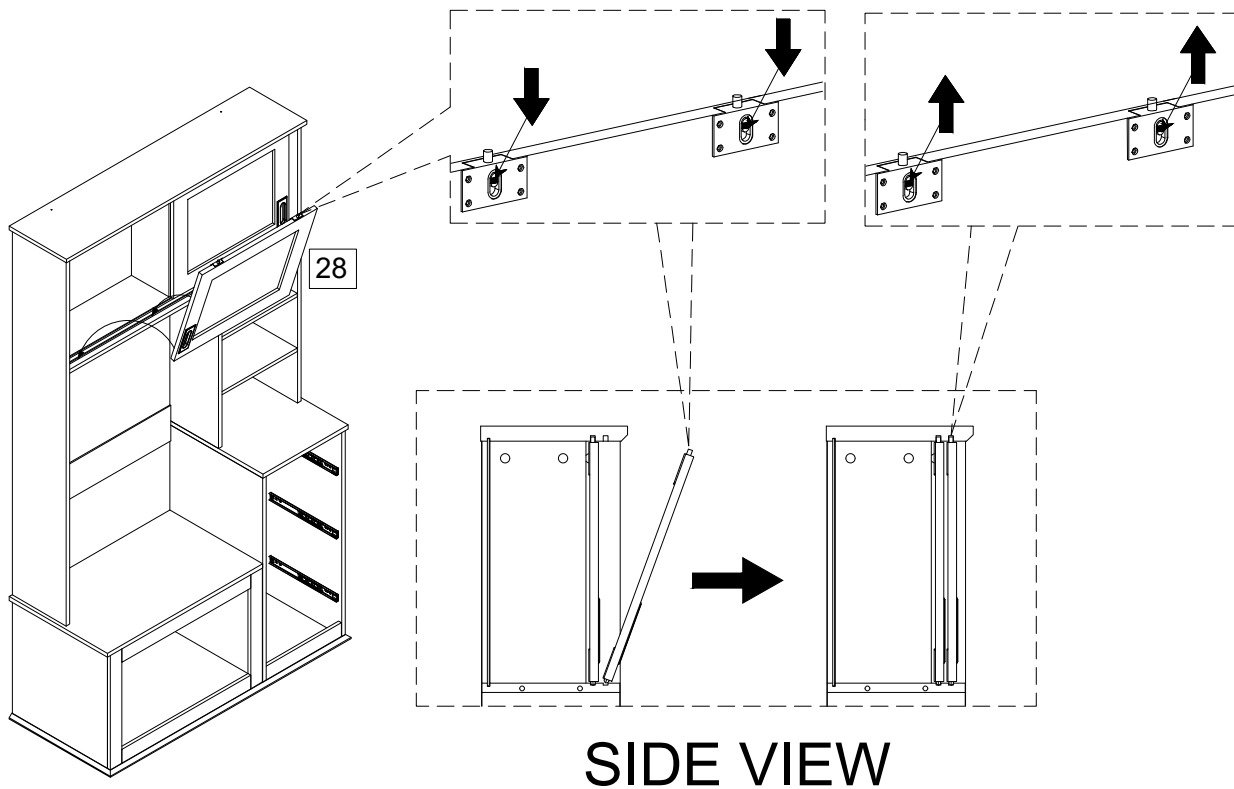

Step 30

Étape 30

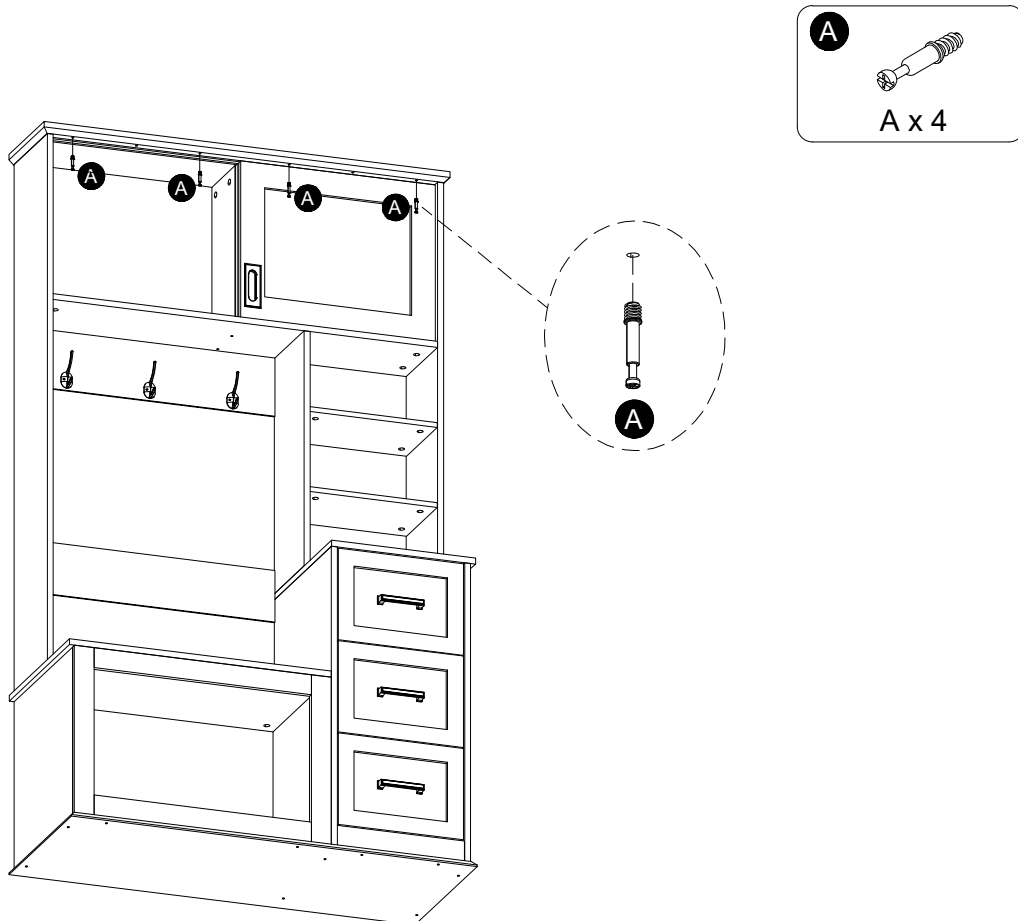

Assembly Instructions /instructions de montage

Step 31

Étape 31

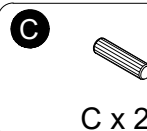
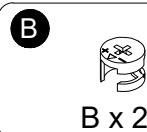
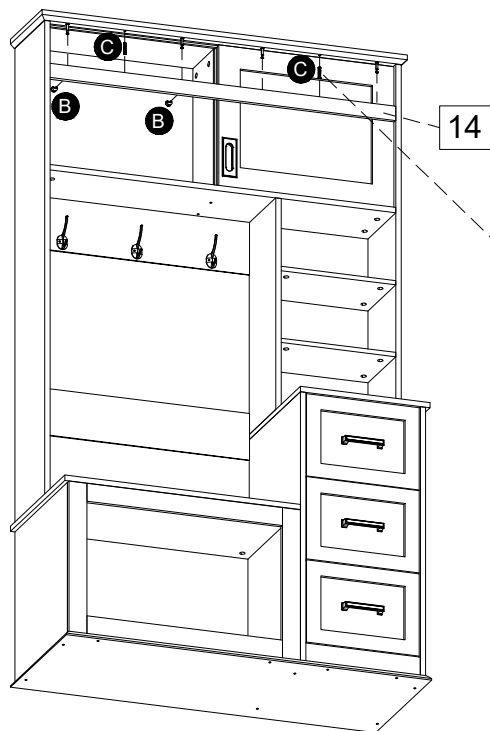

Step 32

Étape 32

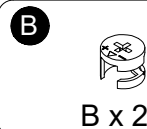
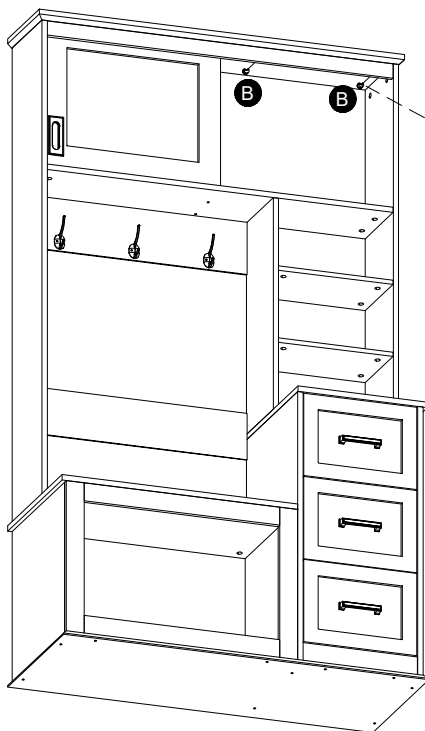

Assembly Instructions /instructions de montage

Step 33

Étape 33

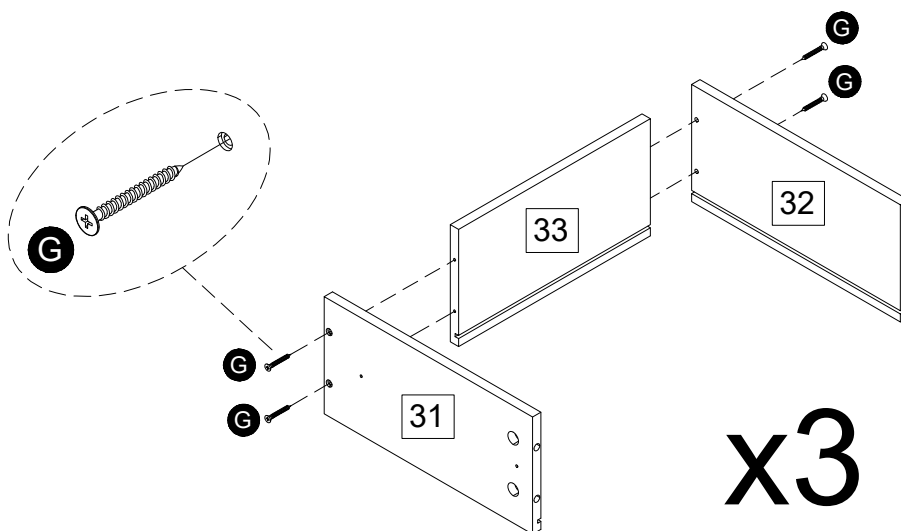

Step 34

Étape 34

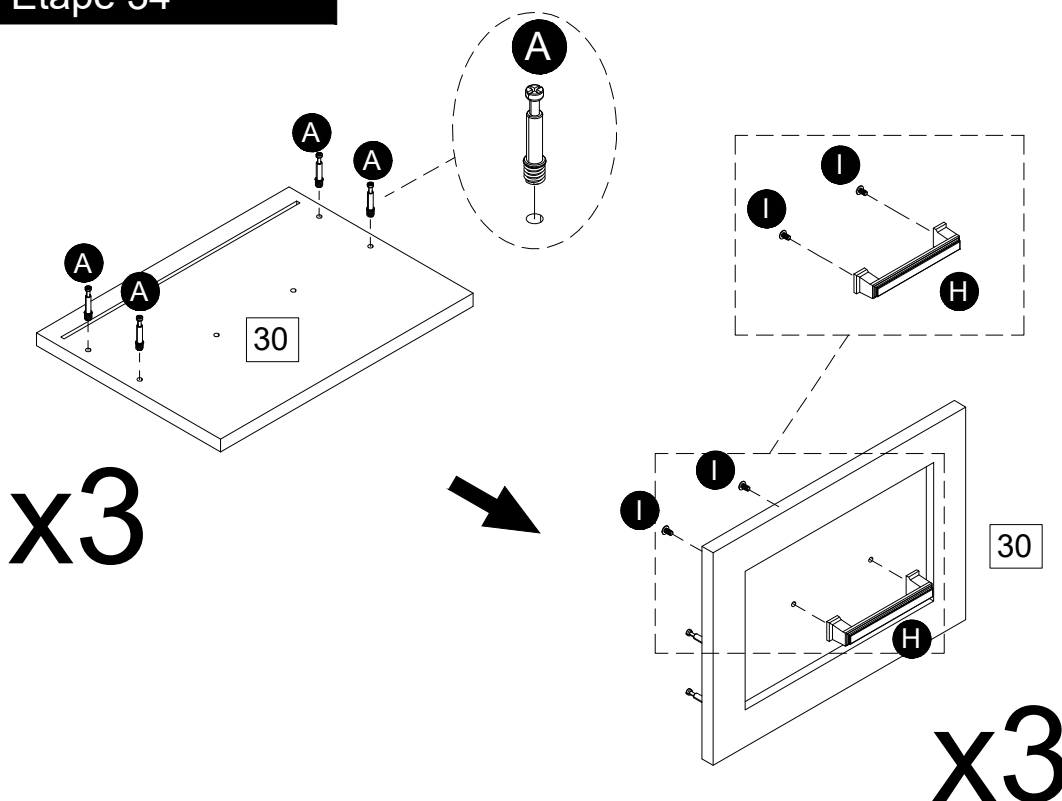
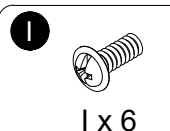
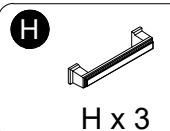
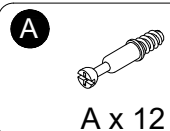

Assembly Instructions /instructions de montage

Step 35

Étape 35

B



B x 12

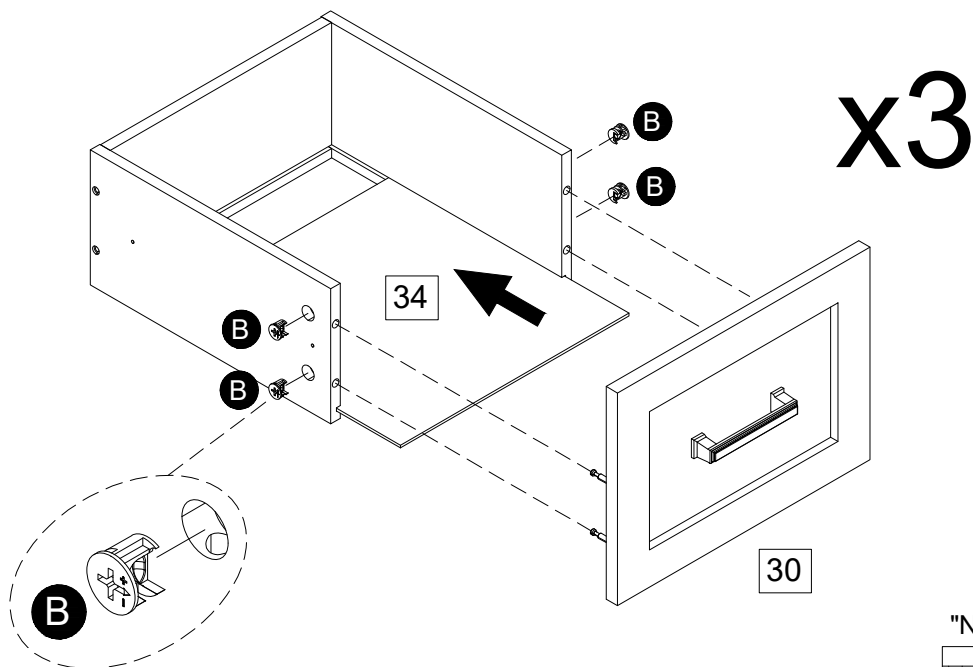

"Need to rotate and tighten B"

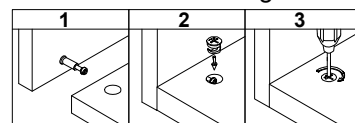

Step 36

Étape 36

R2-Slider runner



R2 x 6

E



E x 12

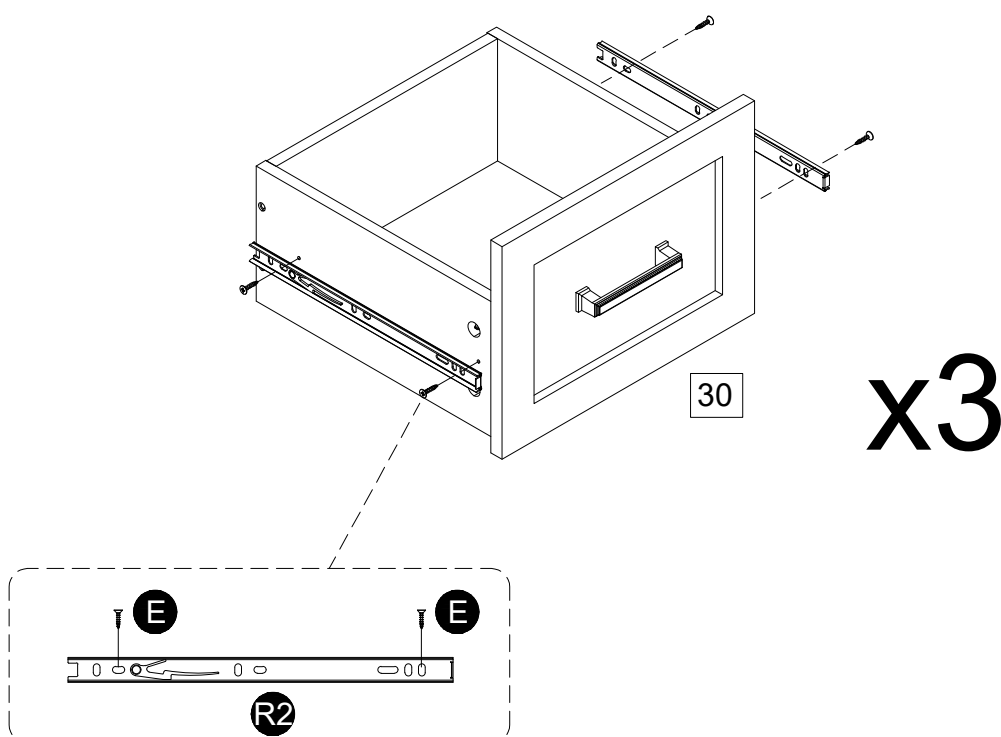

Assembly Instructions /instructions de montage

Step 37

Étape 37

1. Check Before Installing: Ensure the rails are secure and ball bearings are in place.

1. Vérifier avant l'installation: s'assurer que les rails sont sécurisés et que les roulements à billes sont en place.

2. Prepare: Slide the ball bearings to the front of the rails before closing.

2. Préparer: faites glisser les roulements à billes à l'avant des rails avant de les fermer.

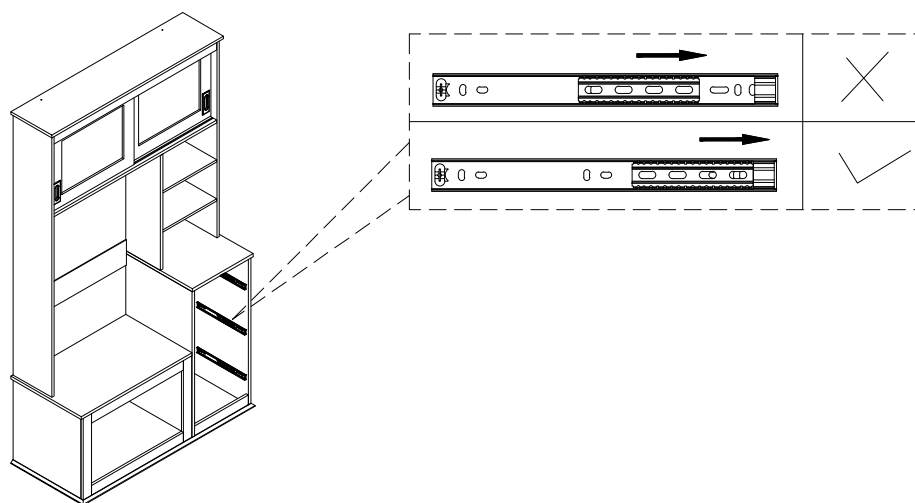

3. Align & Insert: Line up the drawer rails with the main slides and insert both sides at once.

Aligner et insérer: aligner les rails du tiroir avec les glissières principales et insérer les deux côtés à la fois.

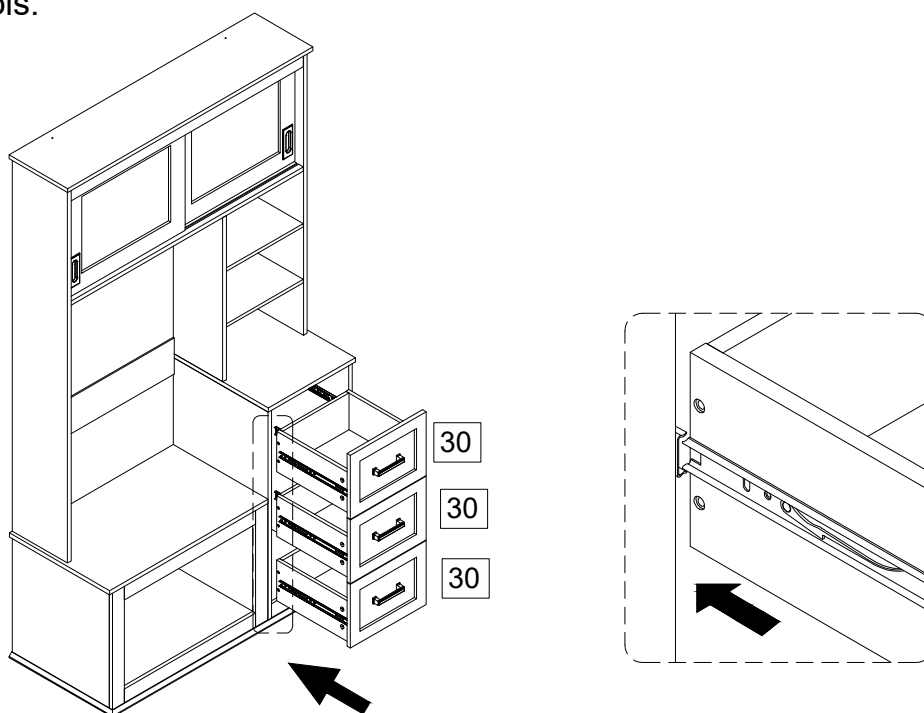

4. Fit: Open and close the drawer slowly three times to align and seat the ball bearings.

4. Ajustement: ouvrir et fermer le tiroir lentement trois fois pour aligner et asseoir les roulements à billes.

Assembly Instructions /instructions de montage

Step 38

Étape 38

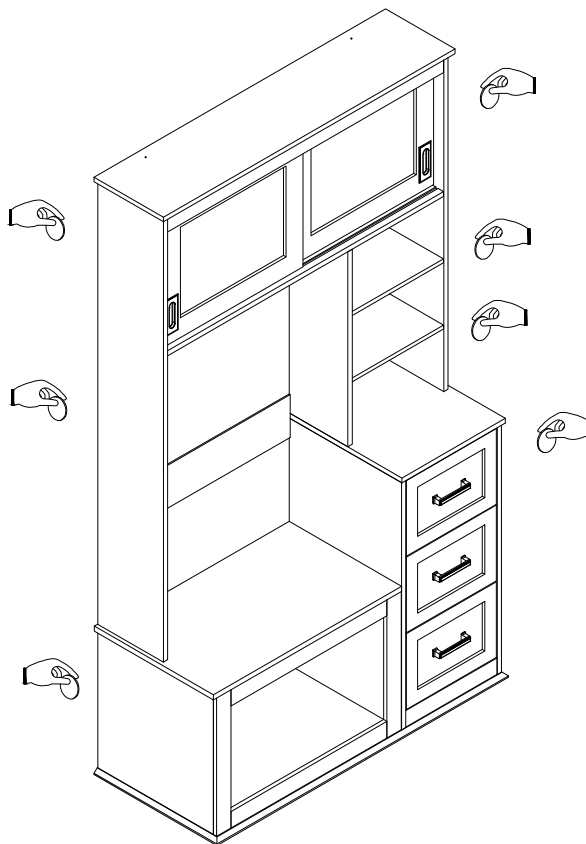
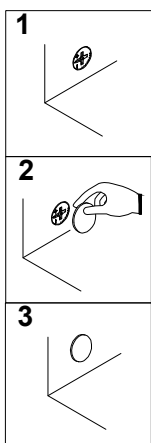
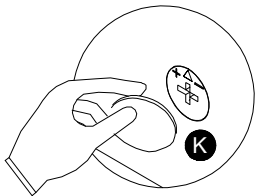

K



K x 40

Step 39

Étape 39

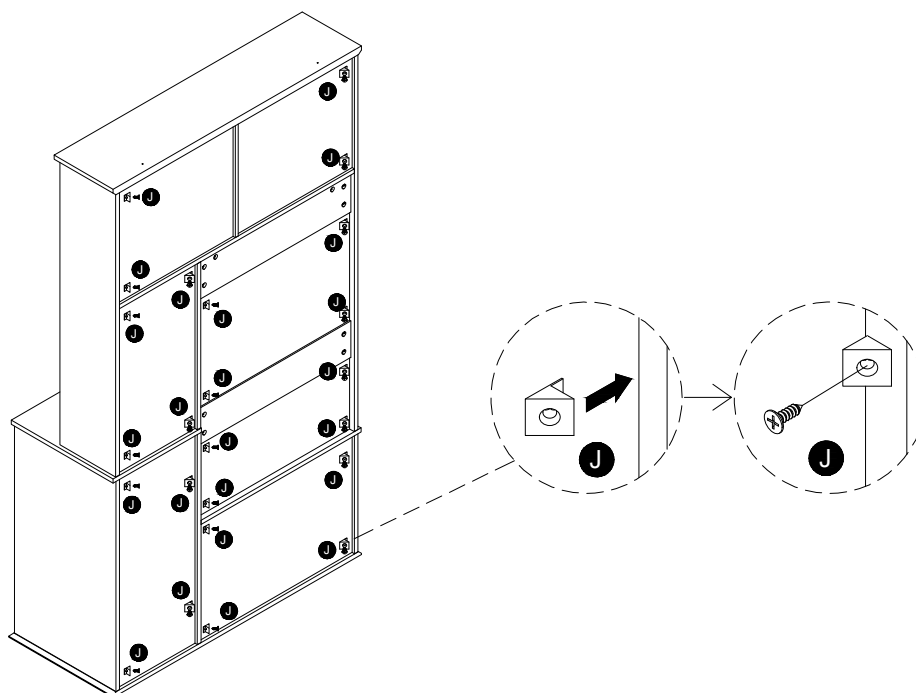

J

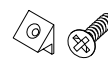

J x 24

Assembly Instructions /instructions de montage

Step 40

Étape 40

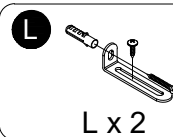

DANGER - To prevent furniture from toppling attach, mount, bolt or otherwise secure to walls and floors. Do not put heavy items on top shelves. Do not place unstable furniture near where children play. An anchor kit suitable for plaster walls is included with this item, if you require a different kit consult your nearest hardware store.

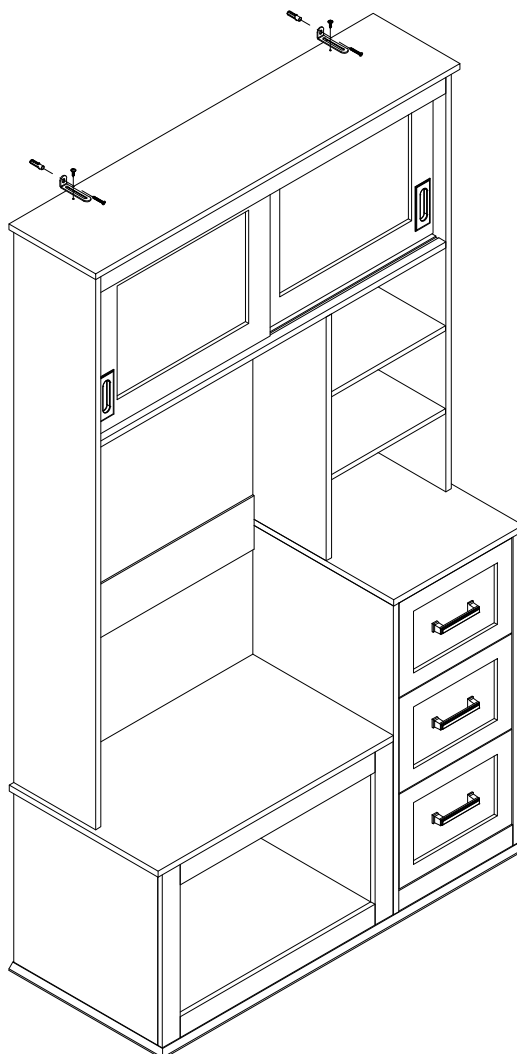
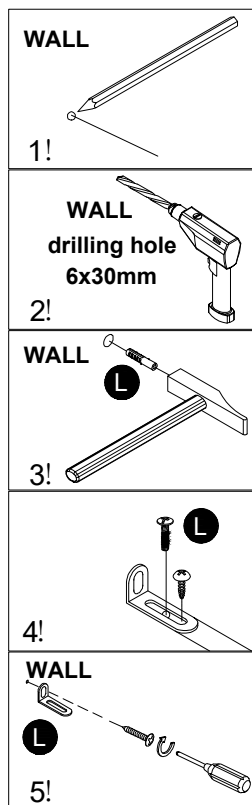

Assembly is complete.
L'assemblage est terminé.