

User's Manual

Sofa

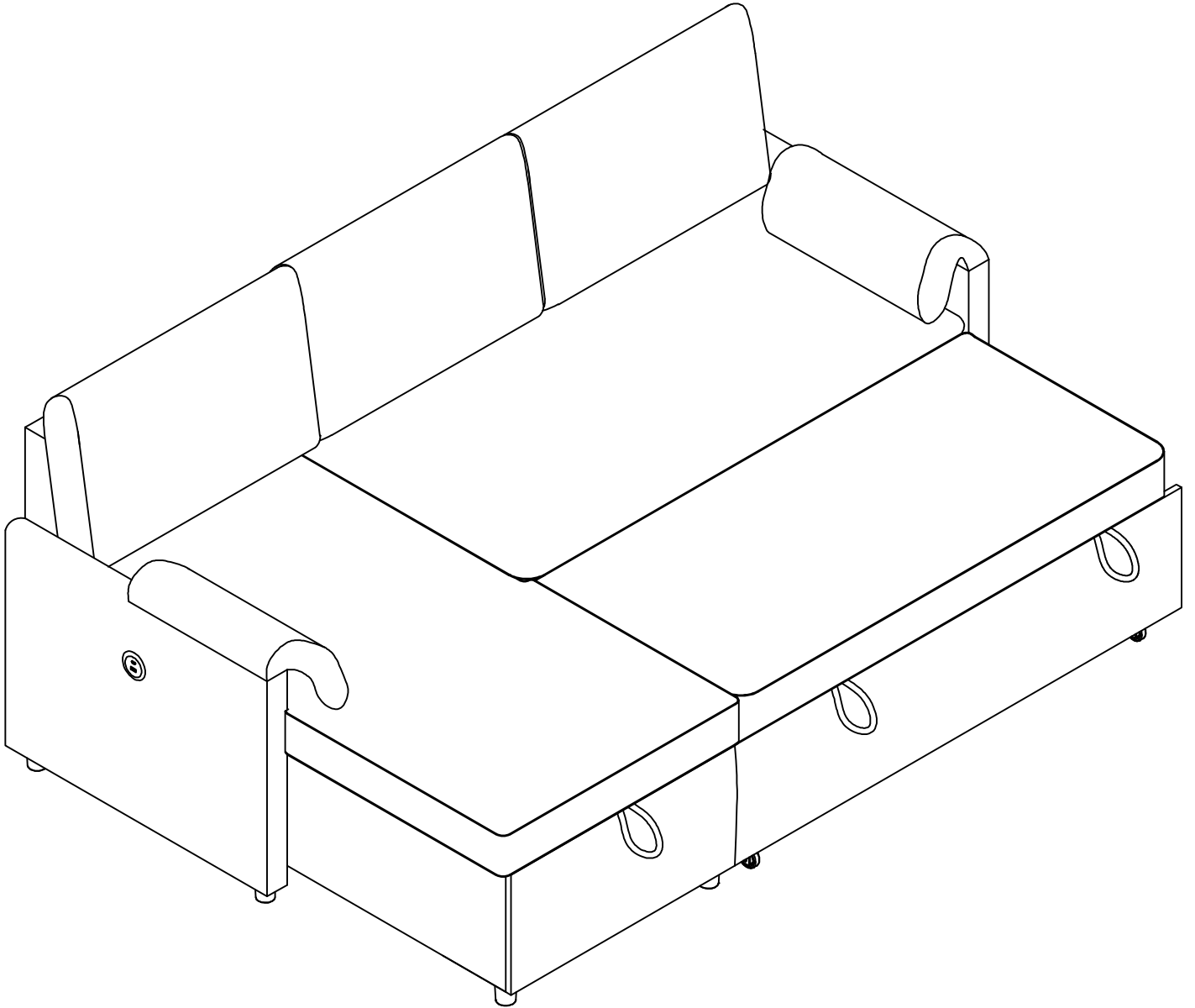

Attention:

1. Please install other parts first, and then open the compressed backrest and seat cushion.
2. Be careful not to scratch the product when opening the compressed package.
3. The sponge is expected to recover in 48 hours, and you can speed up the recovery by patting the backrest.

Assembly Option ①

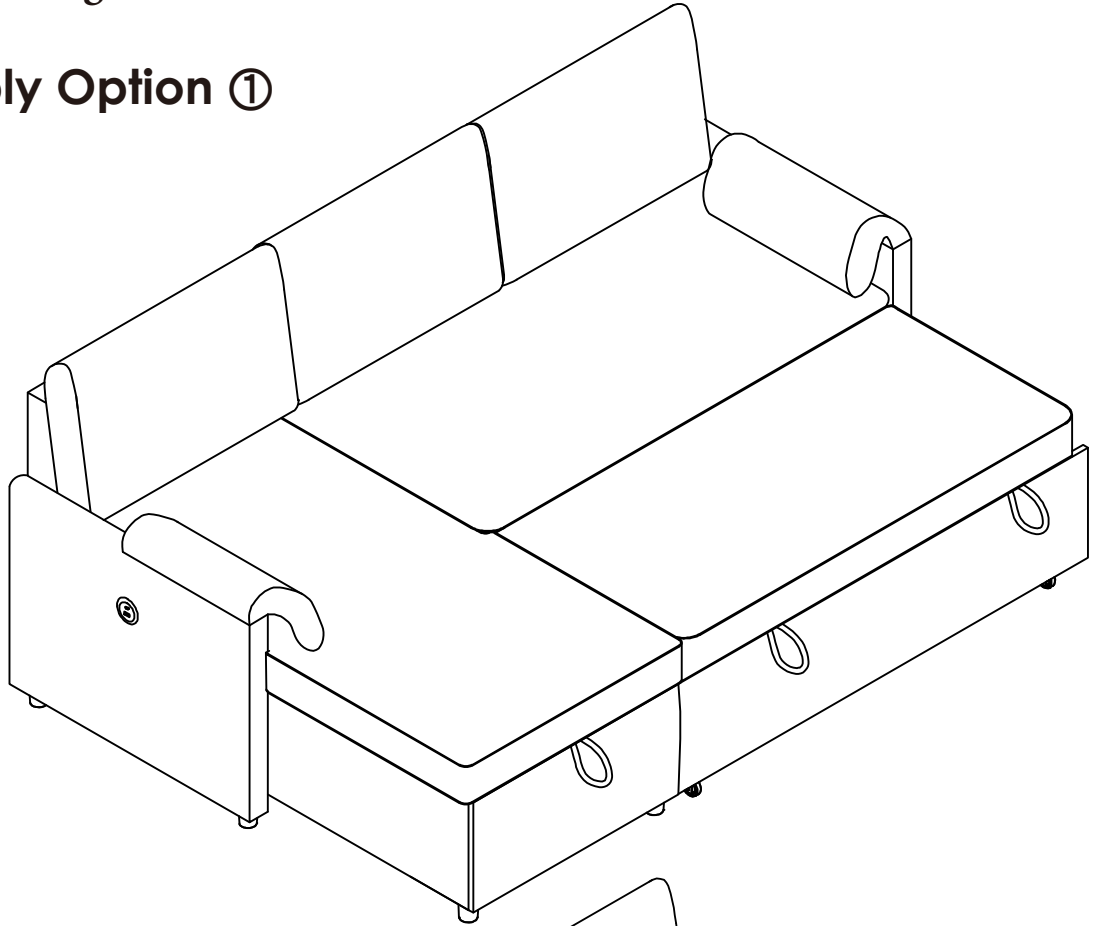

Assembly Option ②

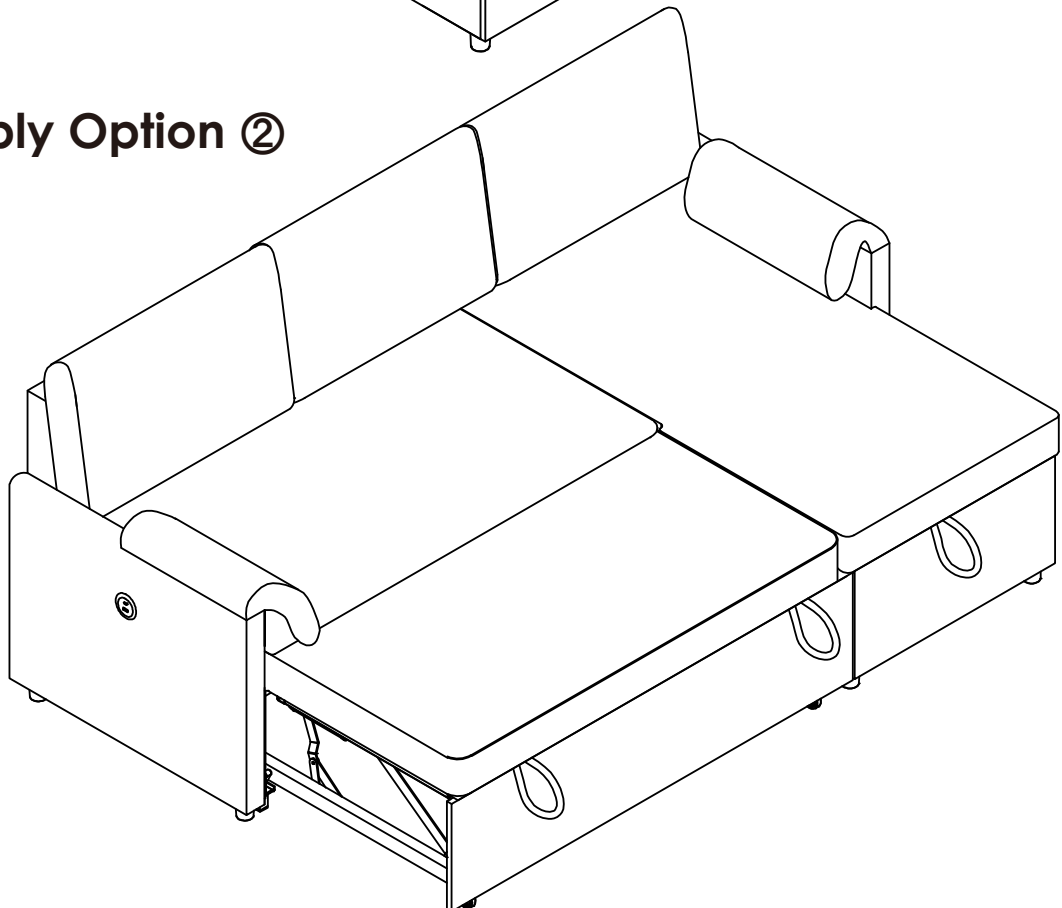

Main Structure Accessories

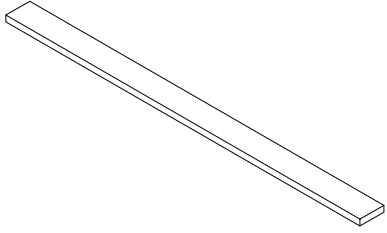
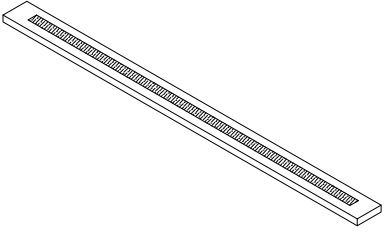
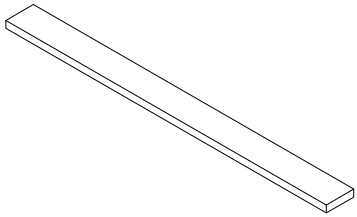
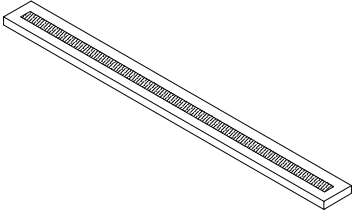
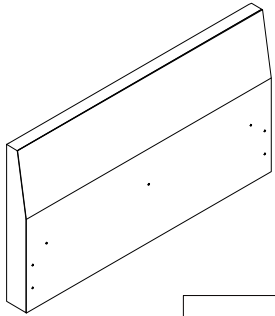
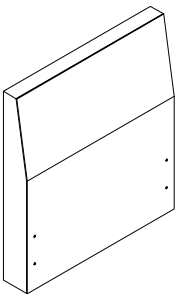
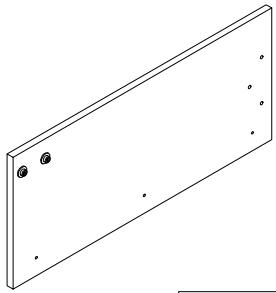
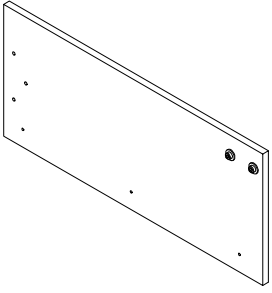
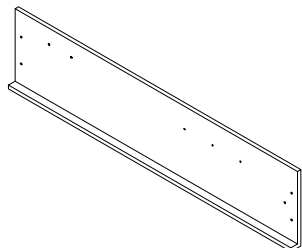
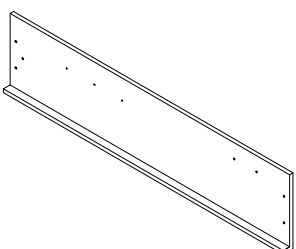
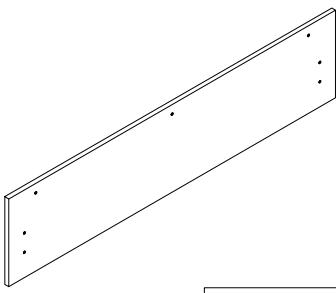
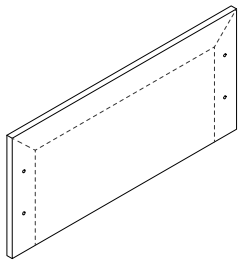
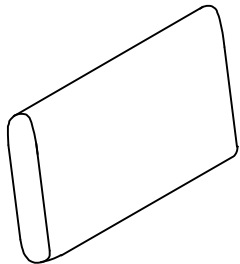
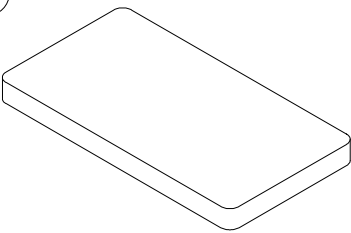
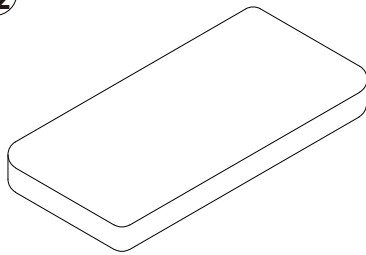
<p>A</p>  <p>18PCS</p>	<p>A1</p>  <p>4PCS</p>	<p>B</p>  <p>9PCS</p>
<p>B1</p>  <p>2PCS</p>	<p>C</p>  <p>1PC</p>	<p>C1</p>  <p>1PC</p>
<p>D</p>  <p>1PC</p>	<p>D1</p>  <p>1PC</p>	<p>D2</p>  <p>1PC</p>
<p>D3</p>  <p>1PC</p>	<p>E</p>  <p>1PC</p>	<p>E1</p>  <p>1PC</p>
<p>F</p>  <p>3PCS</p>	<p>F1</p>  <p>1PC</p>	<p>F2</p>  <p>1PC</p>

Main Structure Accessories

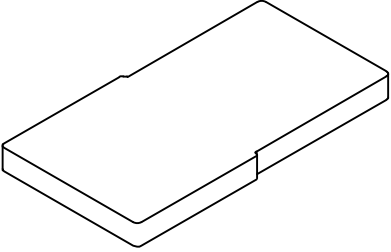
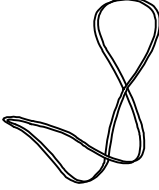
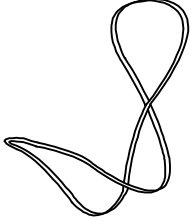
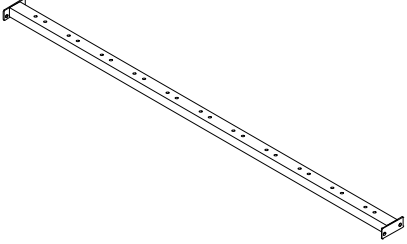
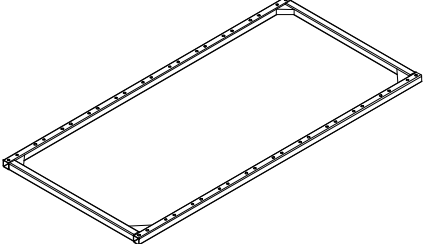
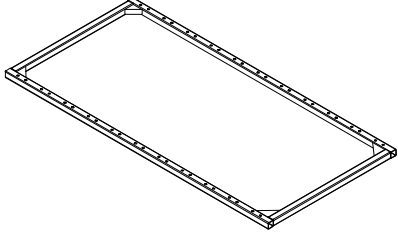
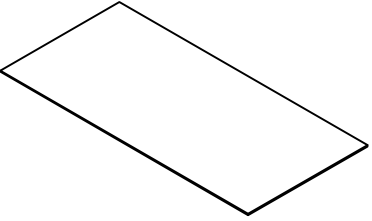
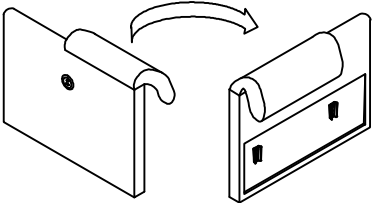
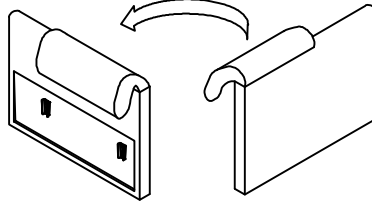
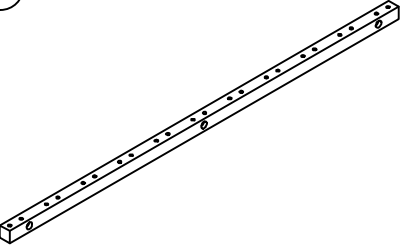
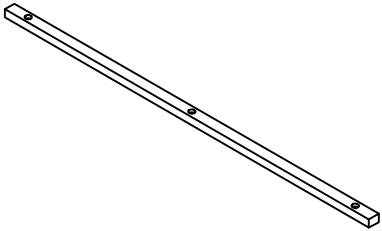
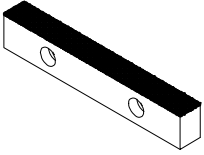
<p>F3</p>  <p>1PC</p>	<p>F4</p>  <p>short</p> <p>1PC</p>	<p>F4 -1</p>  <p>long</p> <p>2PCS</p>
<p>G</p>  <p>1PC</p>	<p>H</p>  <p>1PC</p>	<p>H1</p>  <p>1PC</p>
<p>Q</p>  <p>1PC</p>	<p>R1</p>  <p>1PC</p>	<p>R2</p>  <p>1PC</p>
<p>Z</p>  <p>1PC</p>	<p>Z1</p>  <p>1PC</p>	<p>Z2</p>  <p>2PCS</p>

Structural Accessories

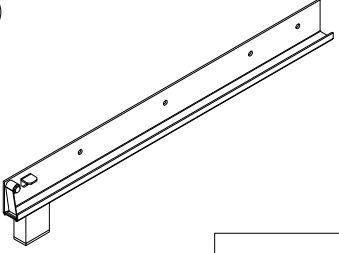
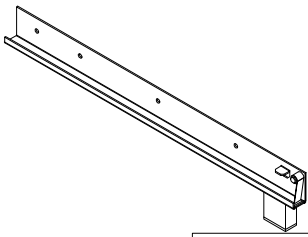
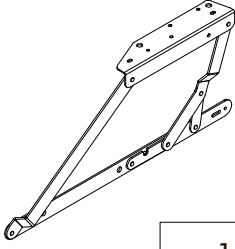
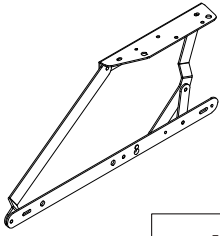
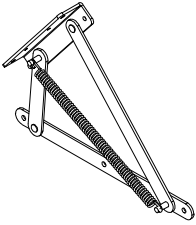
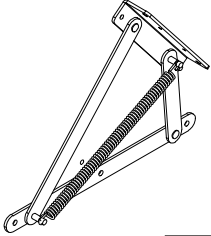
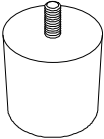
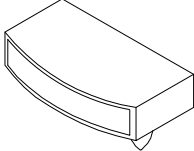
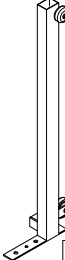
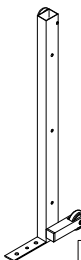
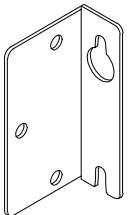
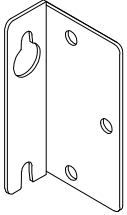
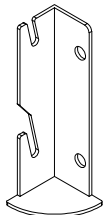
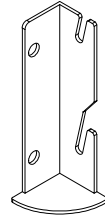
<p>J</p>  <p>1PC</p>	<p>J1</p>  <p>1PC</p>	<p>K</p>  <p>1PC</p>	
<p>K1</p>  <p>1PC</p>	<p>L</p>  <p>1PC</p>	<p>L1</p>  <p>1PC</p>	
<p>M</p>  <p>10PCS</p>	<p>O</p>  <p>66+3PCS</p>	<p>S</p>  <p>1PC</p>	<p>S1</p>  <p>1PC</p>
<p>W</p>  <p>2PCS</p>	<p>X</p>  <p>2PCS</p>	<p>W1</p>  <p>1PC</p>	<p>X1</p>  <p>1PC</p>

Hardware Parts

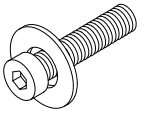
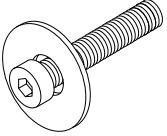
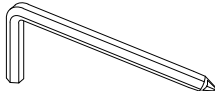
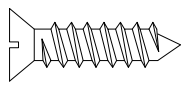
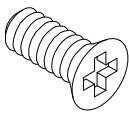
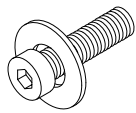
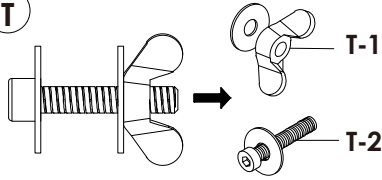
<p>N Small gasket</p>  <p>M8×30mm 10+2PCS</p>	<p>N1 Large gasket</p>  <p>M8×45mm 2PCS</p>	<p>P</p>  <p>1PC</p>	<p>U</p>  <p>M5×14mm 8+1PCS</p>
<p>V</p>  <p>M6×17mm 20+1PCS</p>	<p>Y</p>  <p>M8×18mm 6PCS</p>	<p>T</p>  <p>M8×50mm 1SET</p>	

Main Structure Accessories

CHAISE

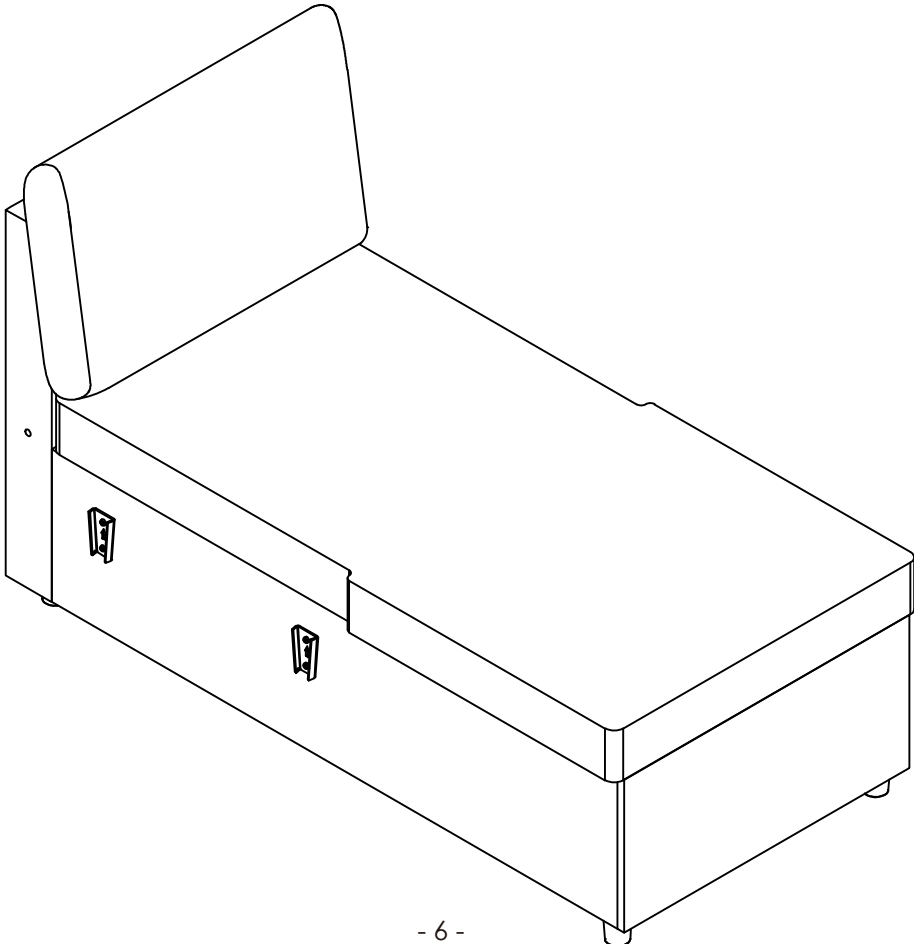
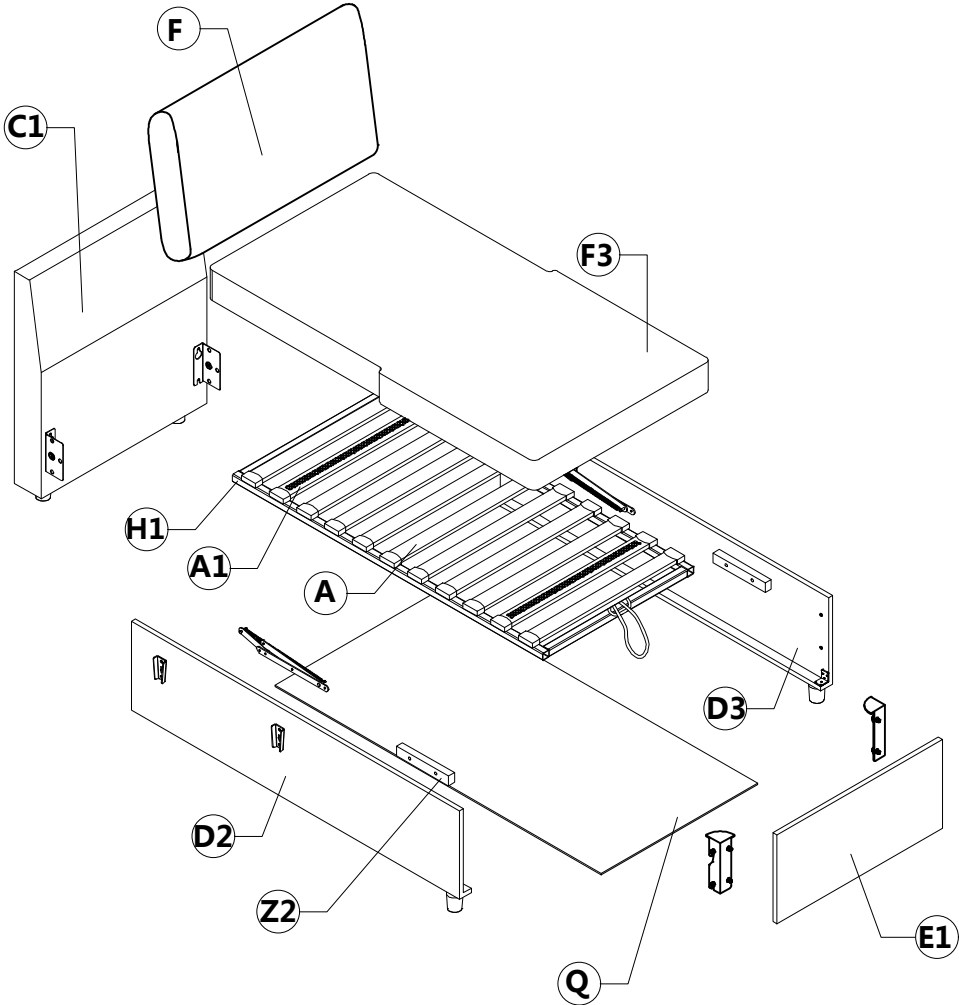



Assembly Steps(EN)

STEP 1

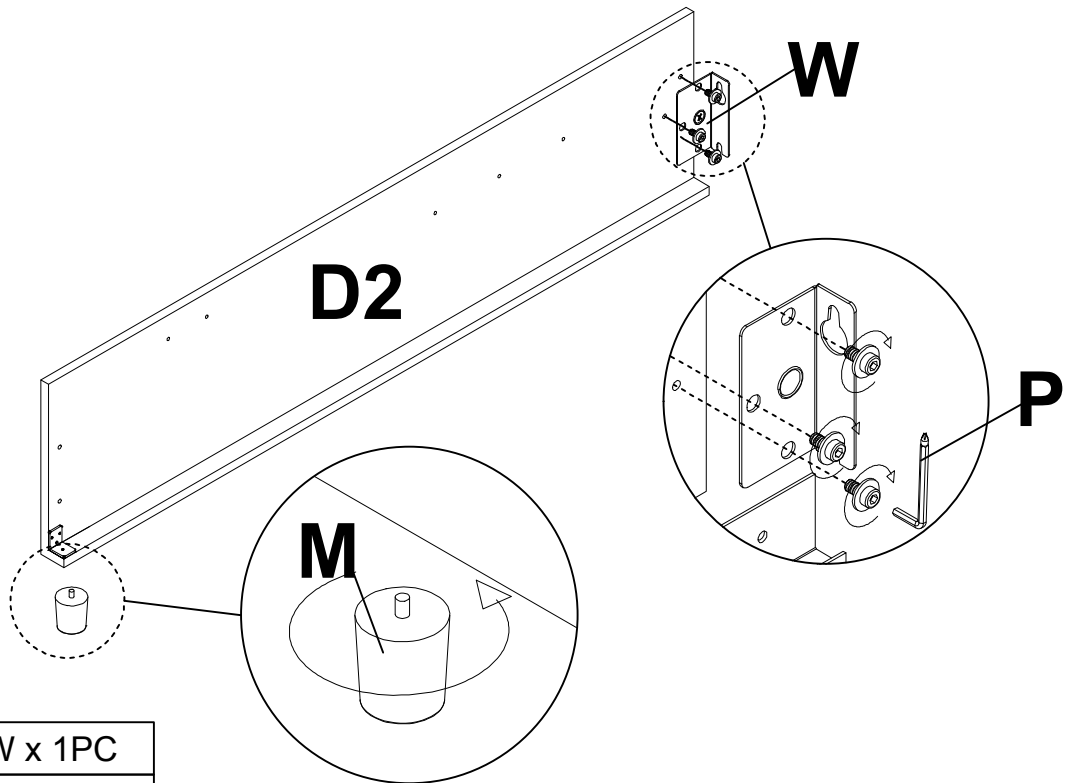
Loosen the screws first, and then lock the hanging piece (W)
Pay attention to the opening up on the side near the foot post





	W x 1PC
	P x 1PC

STEP 2

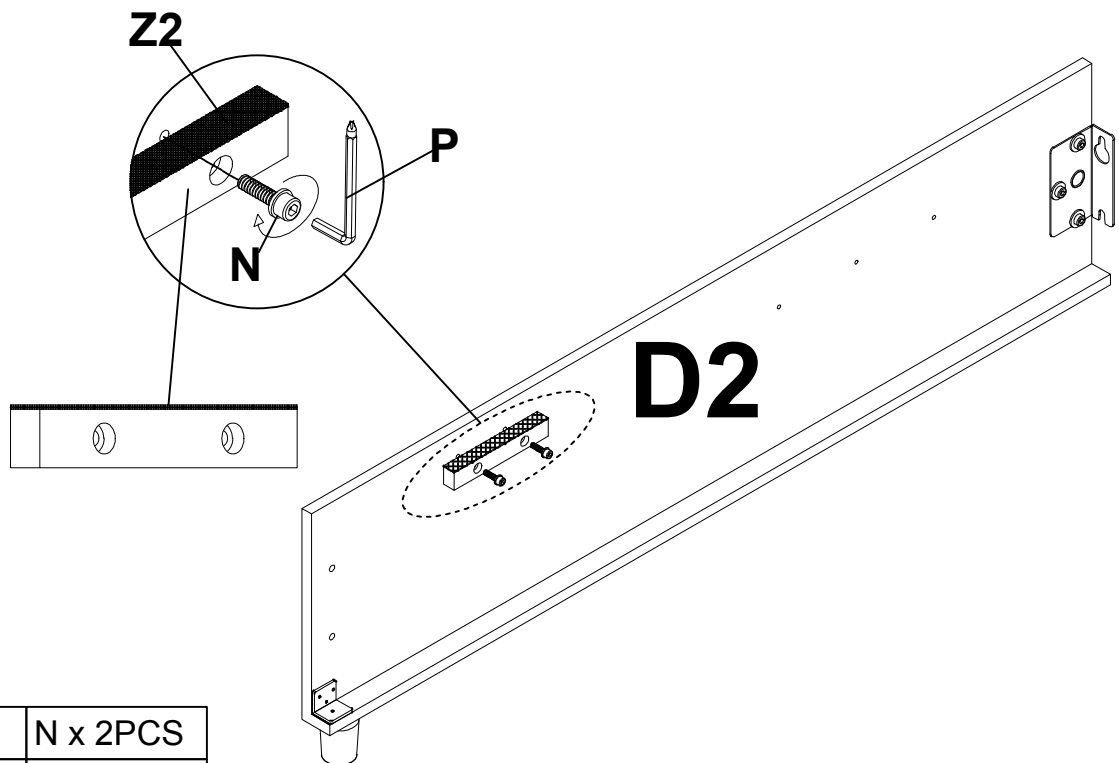
Note that the countersink hole faces outward
and the EVA non-slip sticker faces upward when installing





	N x 2PCS
	P x 1PC

Assembly Steps(EN)

STEP 3

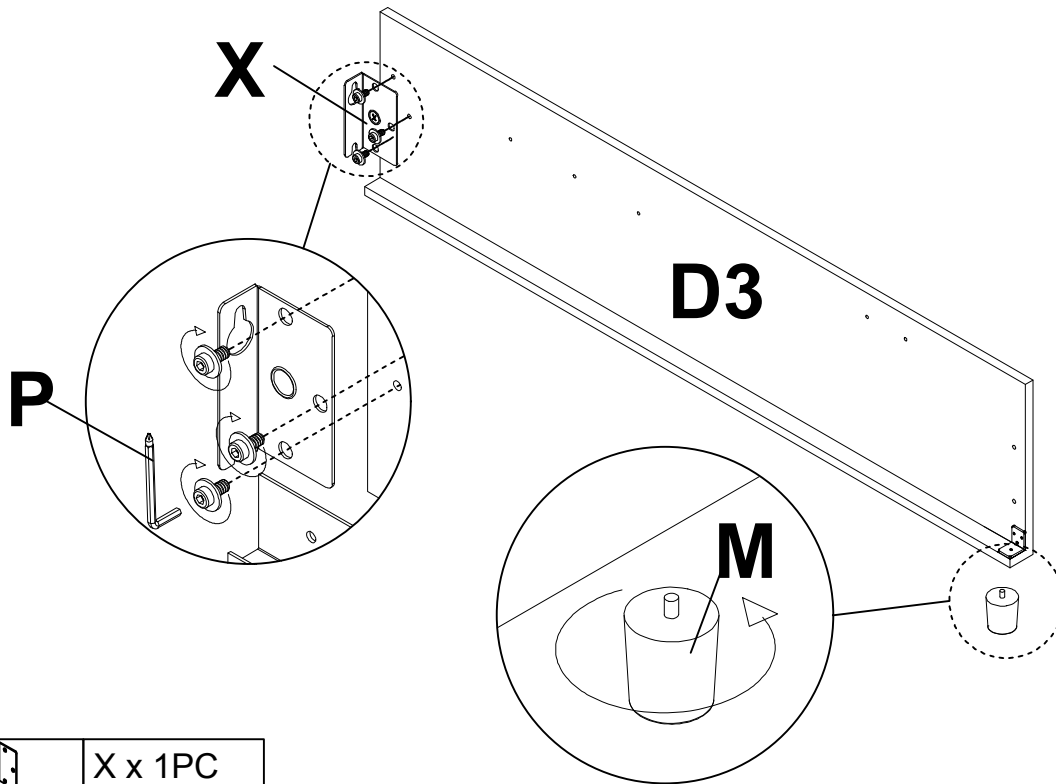
Loosen the screws first, and then lock the hanging piece
Pay attention to the opening up on the side near the foot post





	X x 1PC
	P x 1PC

STEP 4

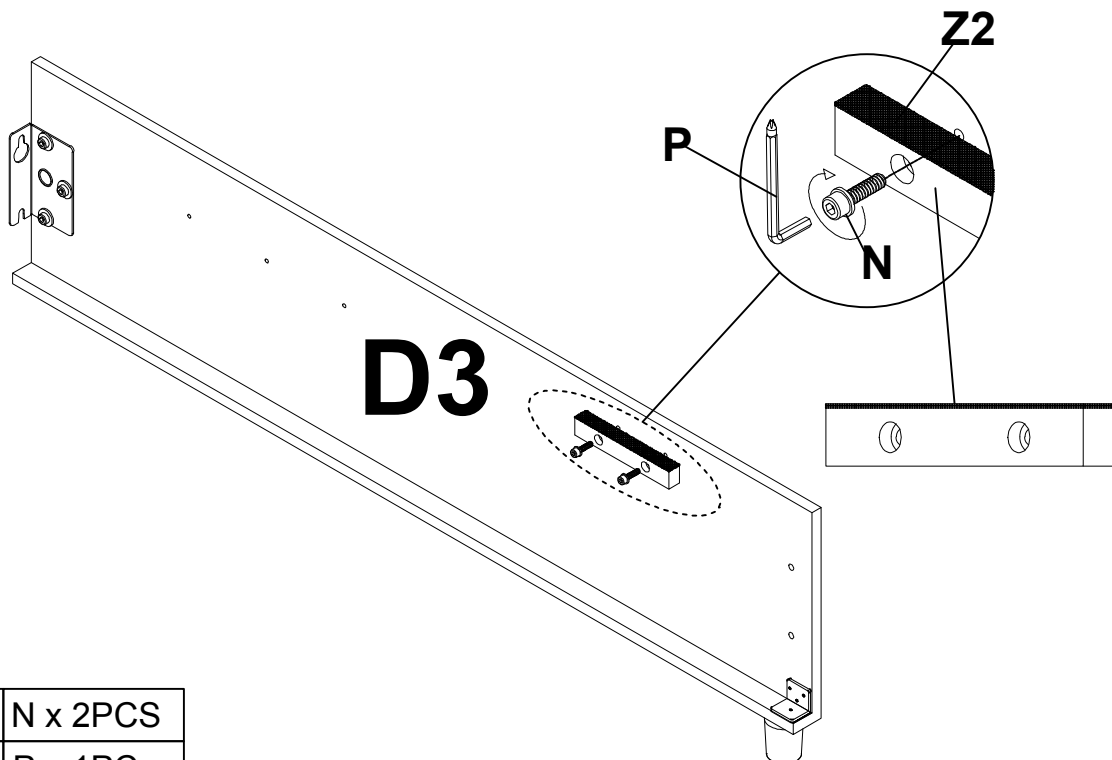
Note that the countersink hole faces outward
and the EVA non-slip sticker faces upward when installing



	N x 2PCS
	P x 1PC

Assembly Steps(EN)

STEP 5

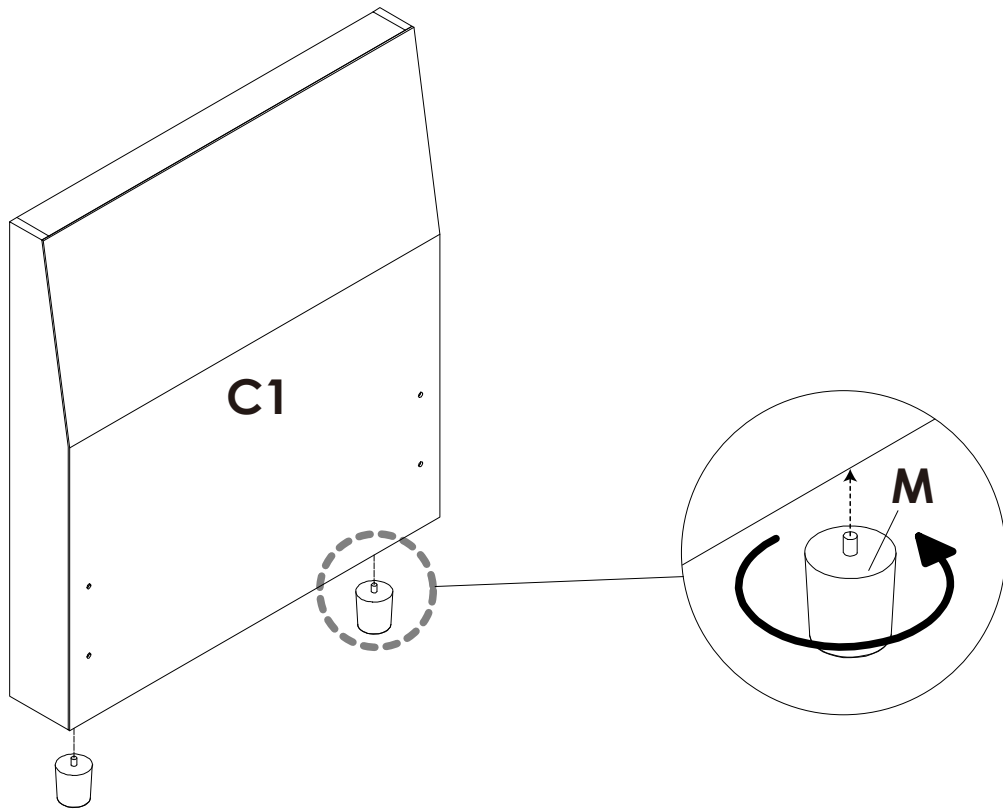

STEP 6

First loosen the screws, install the mounting plate, and then lock the screws.

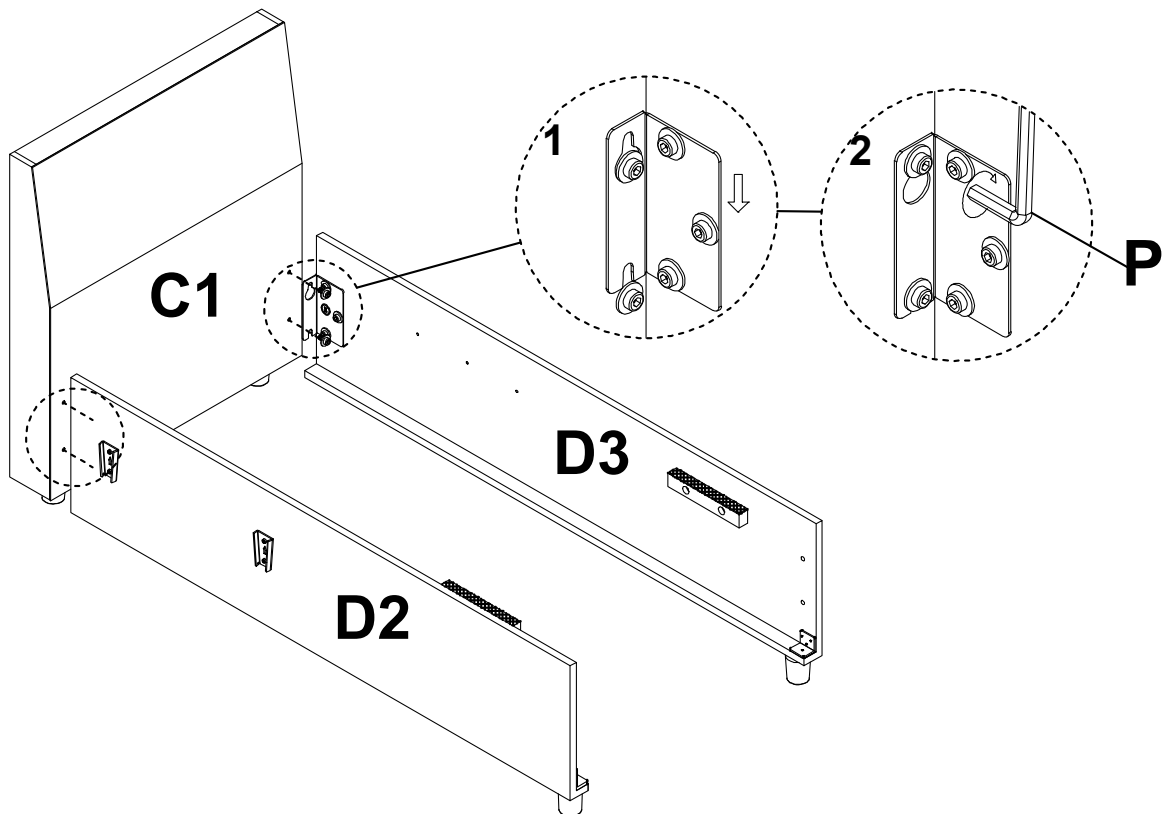

P x 1PC

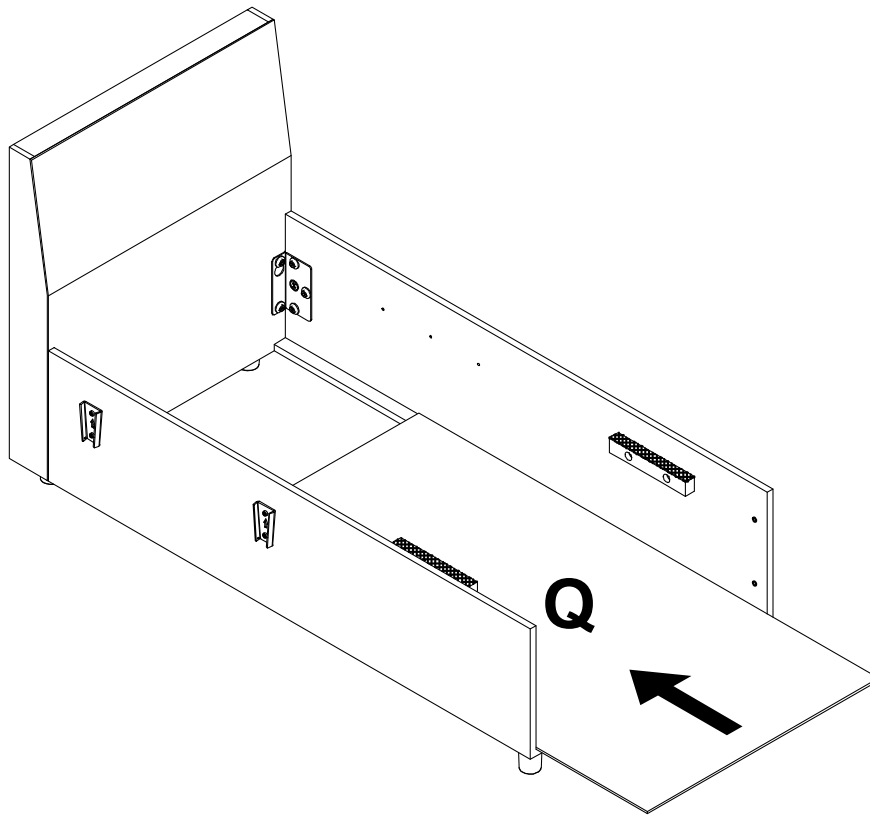

Assembly Steps(EN)

STEP 7

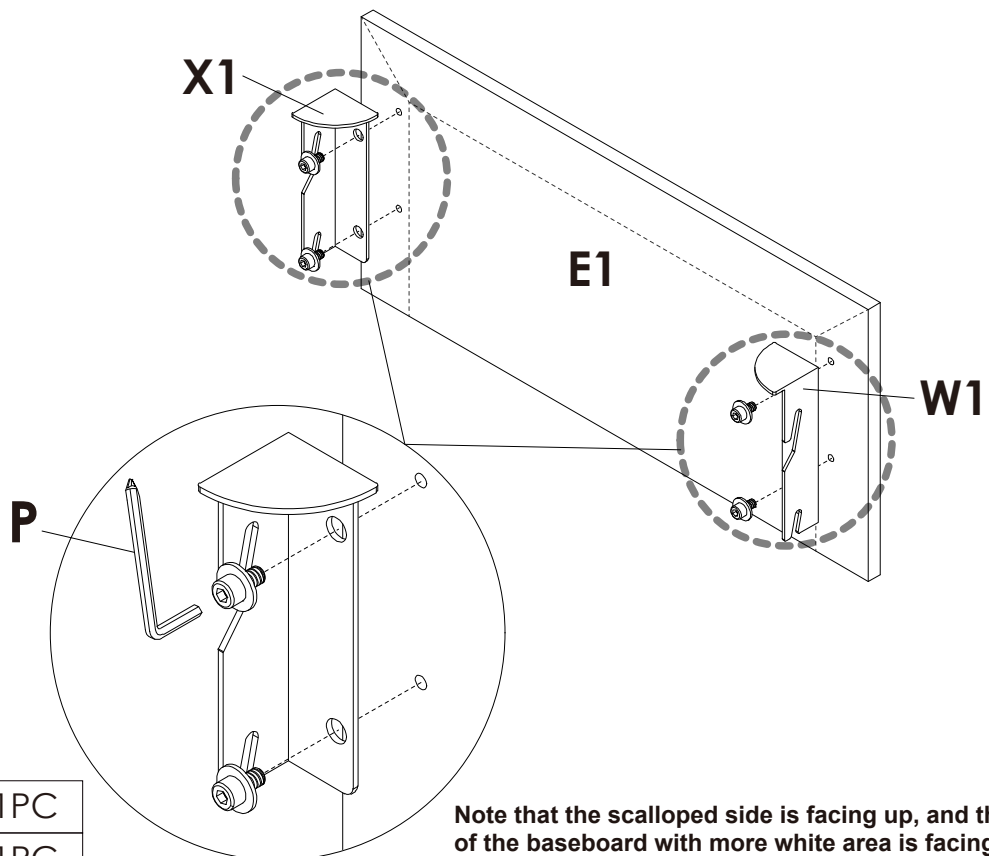

STEP 8



	W1 x 1PC
	X1 x 1PC
	P x 1PC

Note that the scalloped side is facing up, and the side of the baseboard with more white area is facing up.

Assembly Steps(EN)

STEP 9

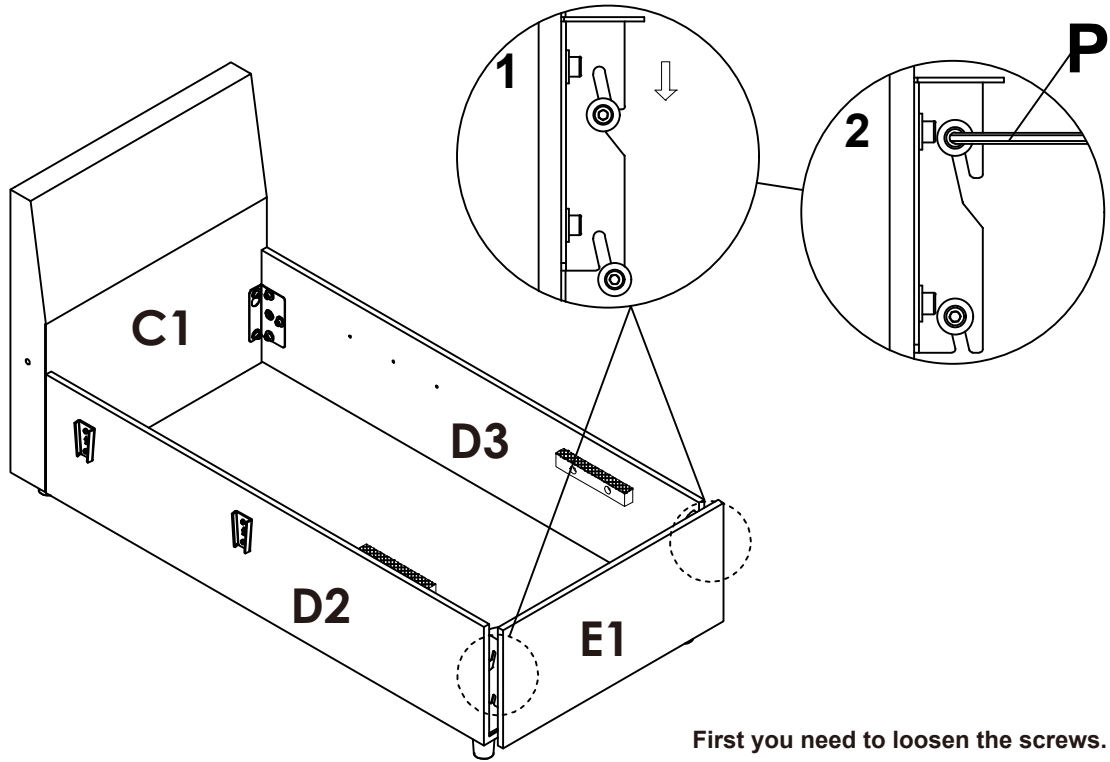

First you need to loosen the screws.



P x 1PC

STEP 10

Note: The accessories should be distinguished between left and right, and the screws should be tightened after installation.

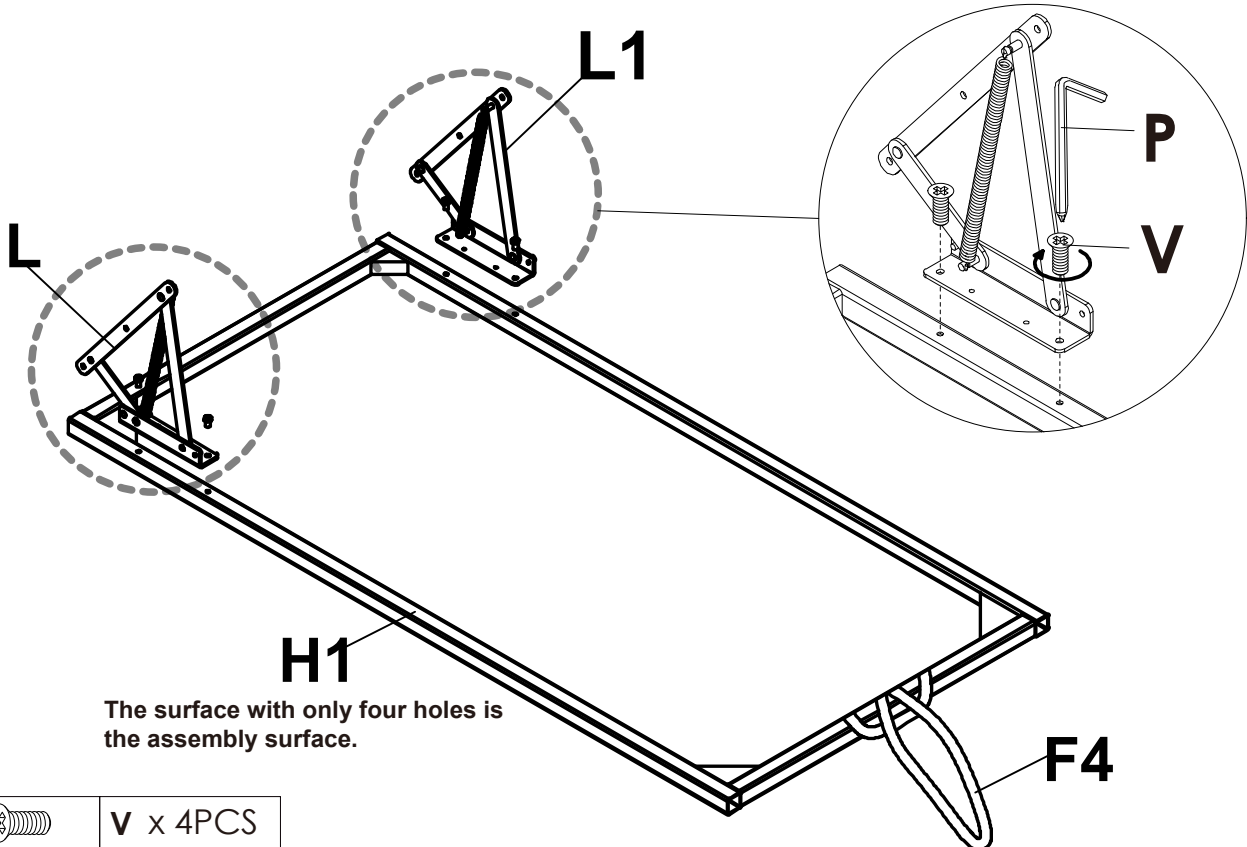

The surface with only four holes is the assembly surface.



V x 4PCS



P x 1PC

Assembly Steps(EN)

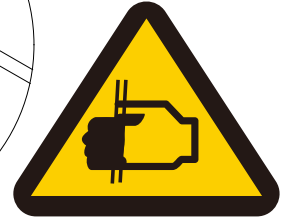
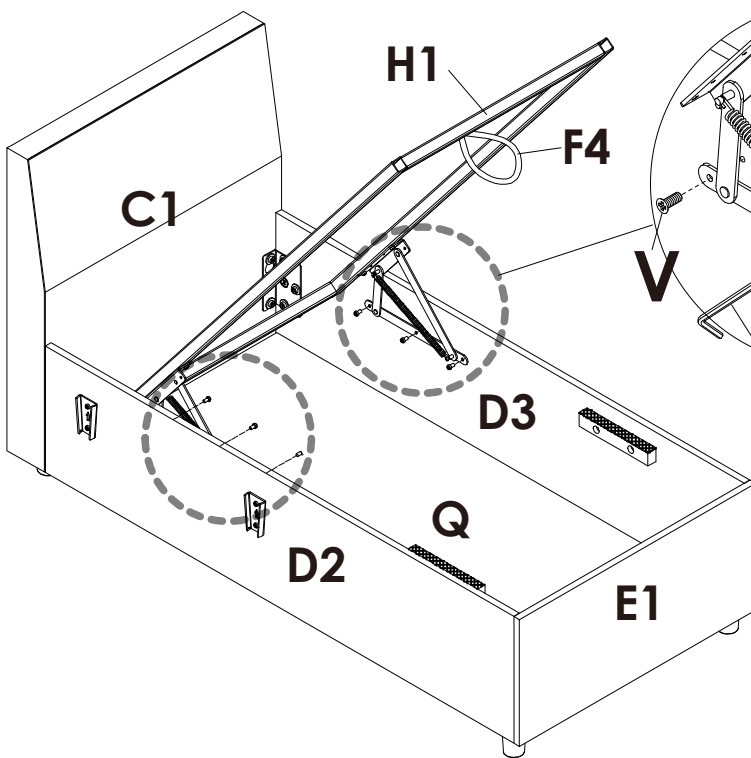

STEP 11

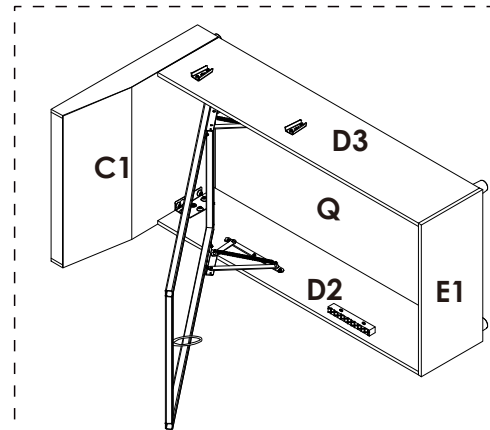

WARNING: HANDS PINCHING



Note: Easier to install when tilted

	V x 6PCS
	P x 1PC

STEP 12

Place the **A1** in the second position and note that the Nylon Fastener side is facing up

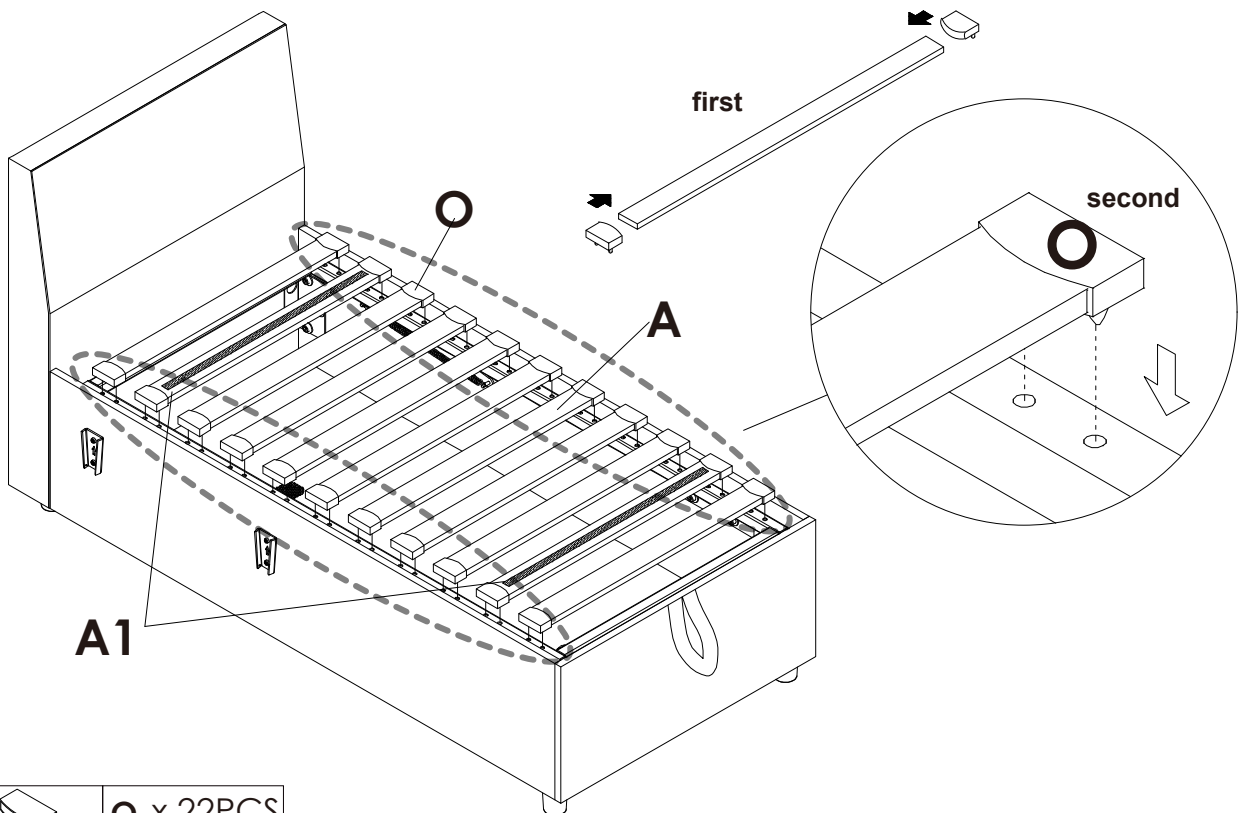

	O x 22PCS
---	-----------

Main Structure Accessories

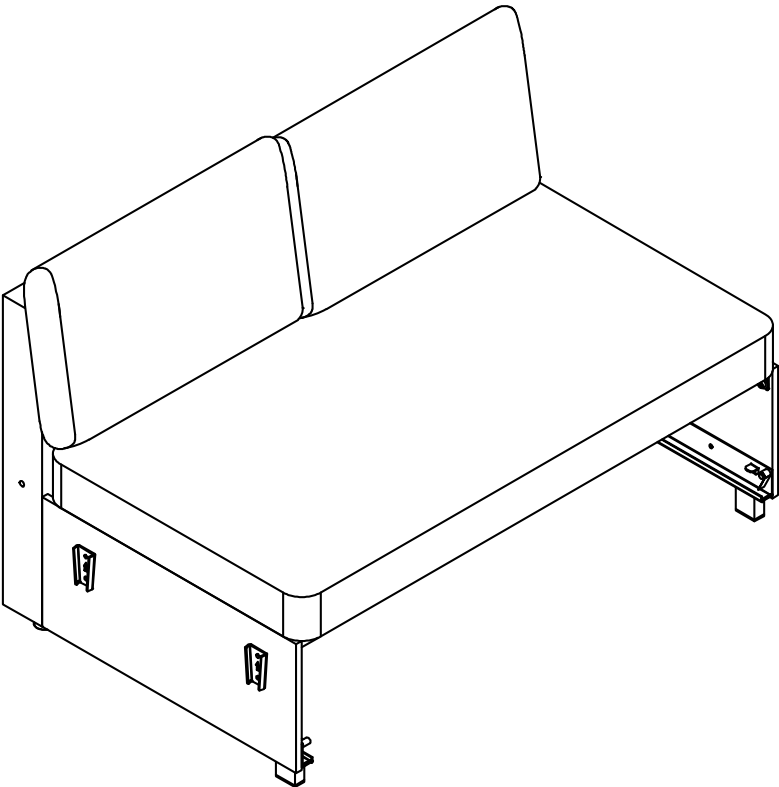
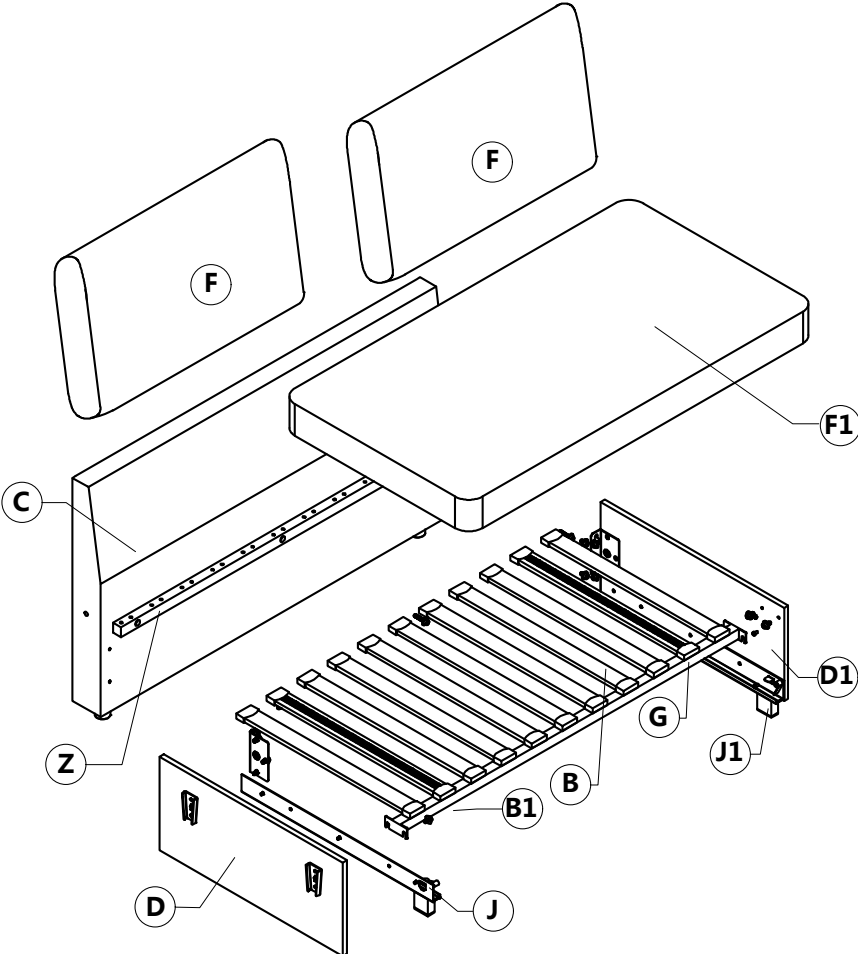

TWO SEATS

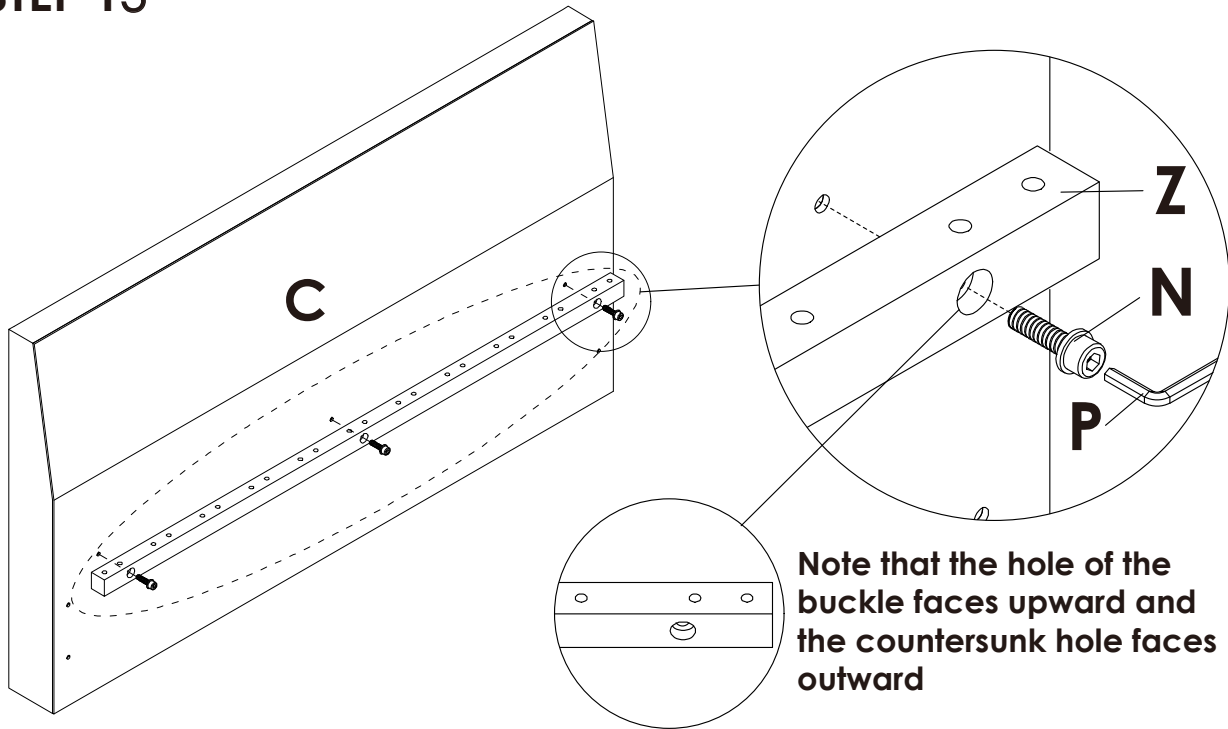

Assembly Steps(EN)

STEP 13



	N x 3PCS
	P x 1PC

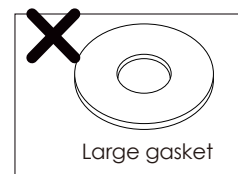
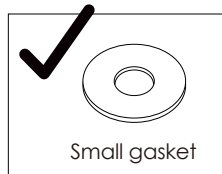

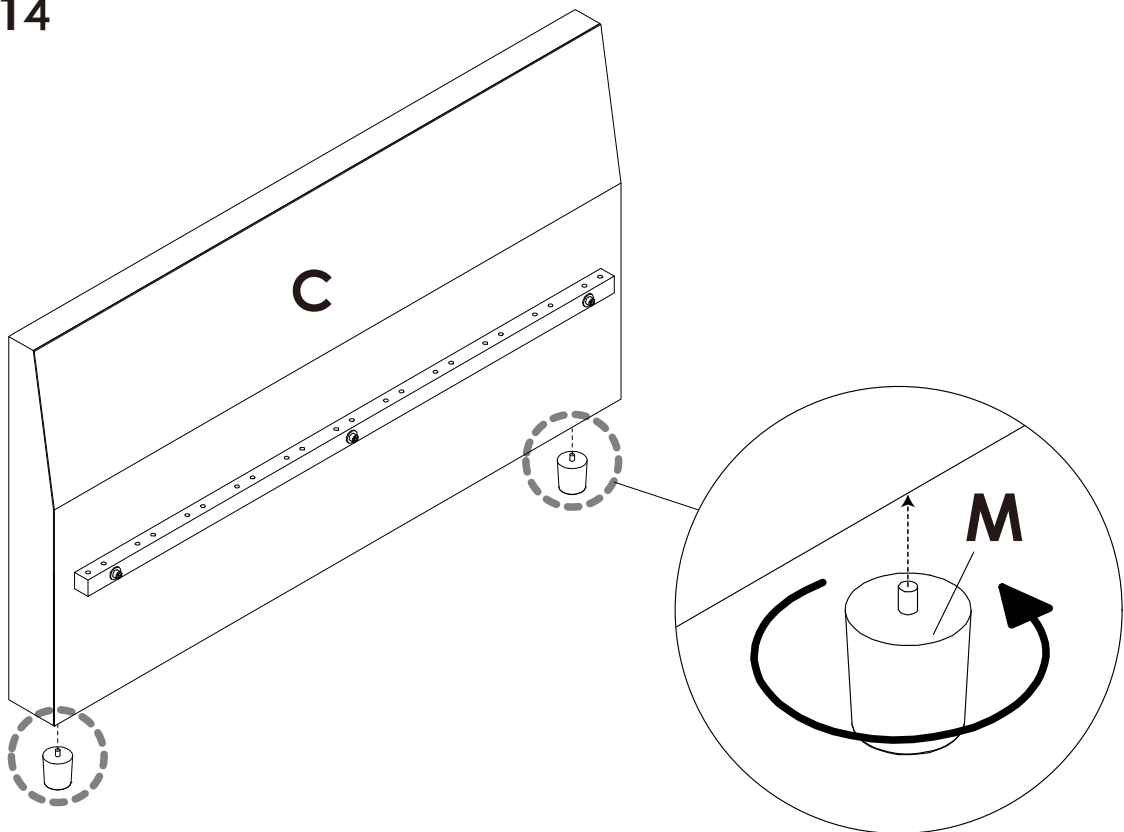

STEP 14

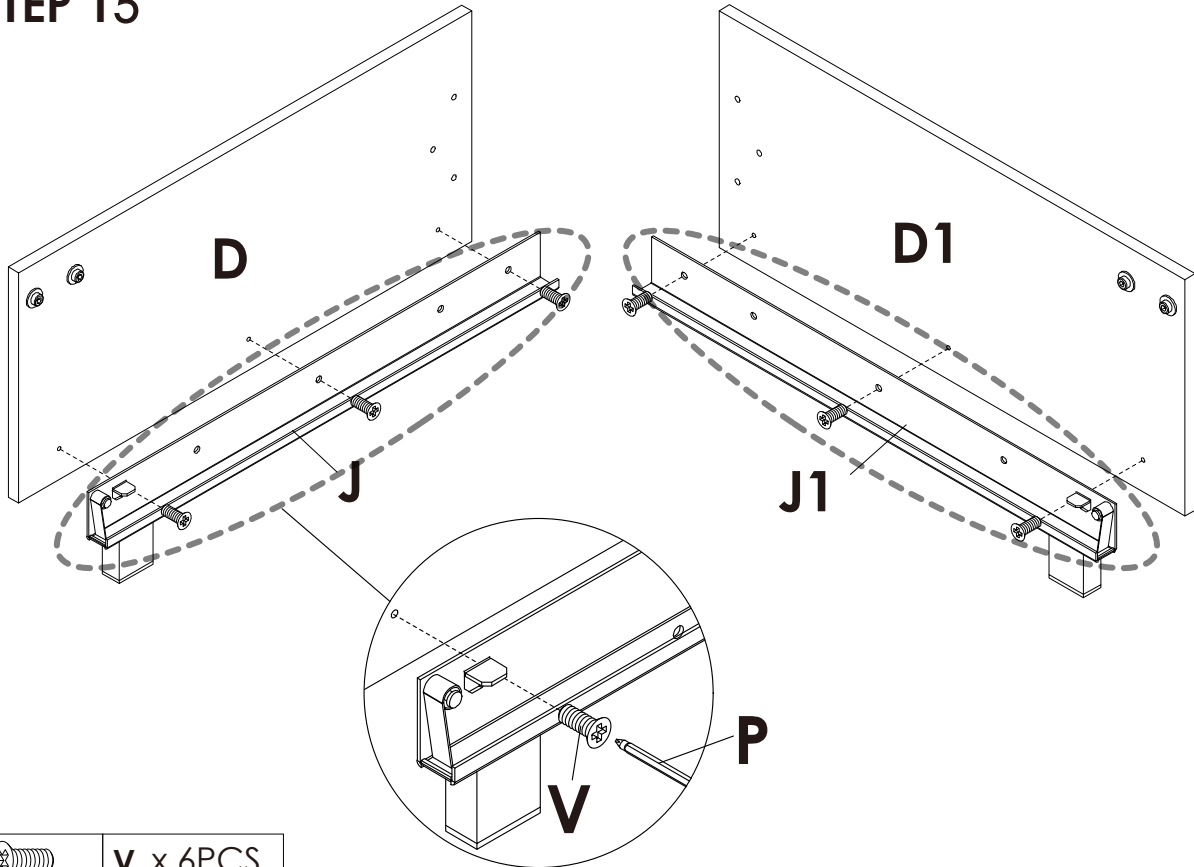

Assembly Steps(EN)

STEP 15





	V x 6PCS
	P x 1PC

STEP 16

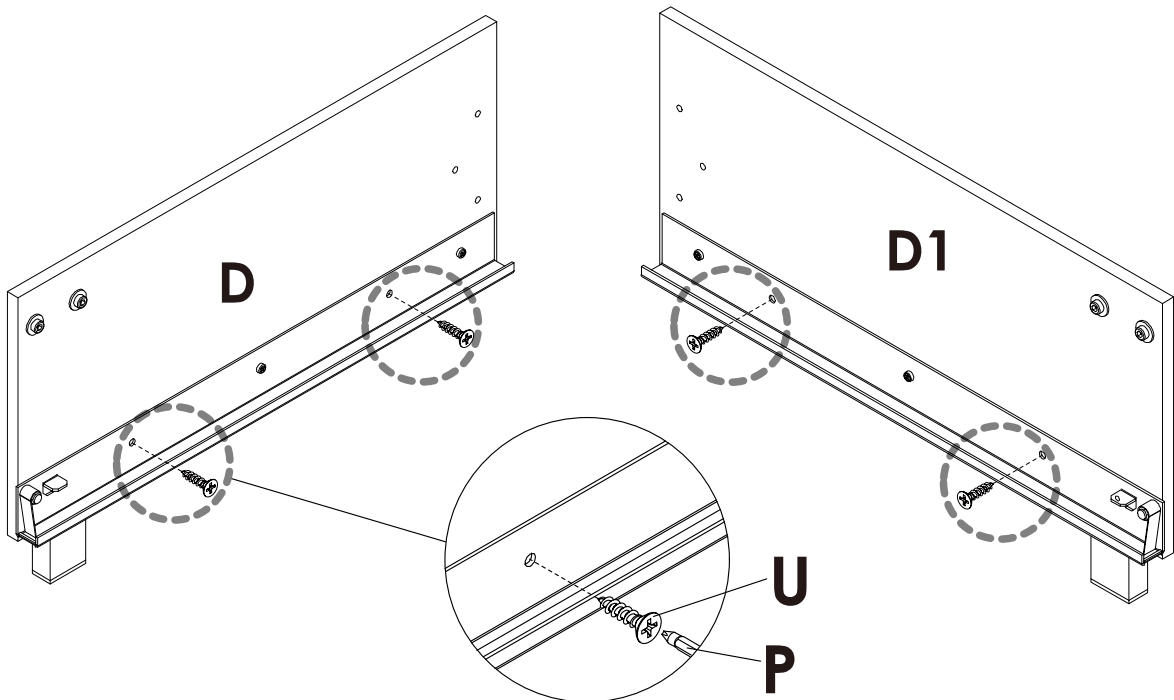
Reinforcing lock with self-tapping screws







	U x 4PCS
	P x 1PC

Tips: Self-tapping screw is an auxiliary reinforcement function, you can choose to reinforce or not.

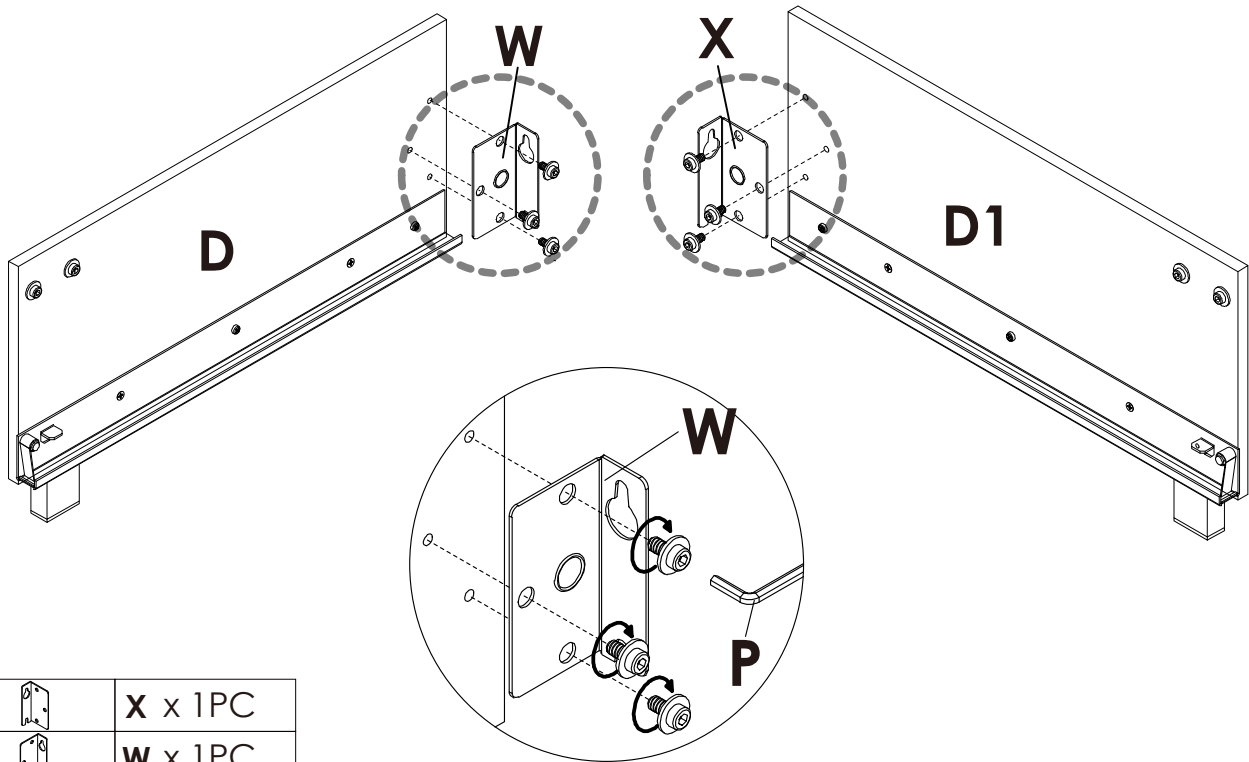
Assembly Steps(EN)

STEP 17 First, loosen the screws properly for a better fit.



	X x 1PC
	W x 1PC
	P x 1PC

STEP 18 There are 2 screws on the left and right bottom of the C board. It is recommended to loosen half of them and then install the mounting plate, and then lock the screws.

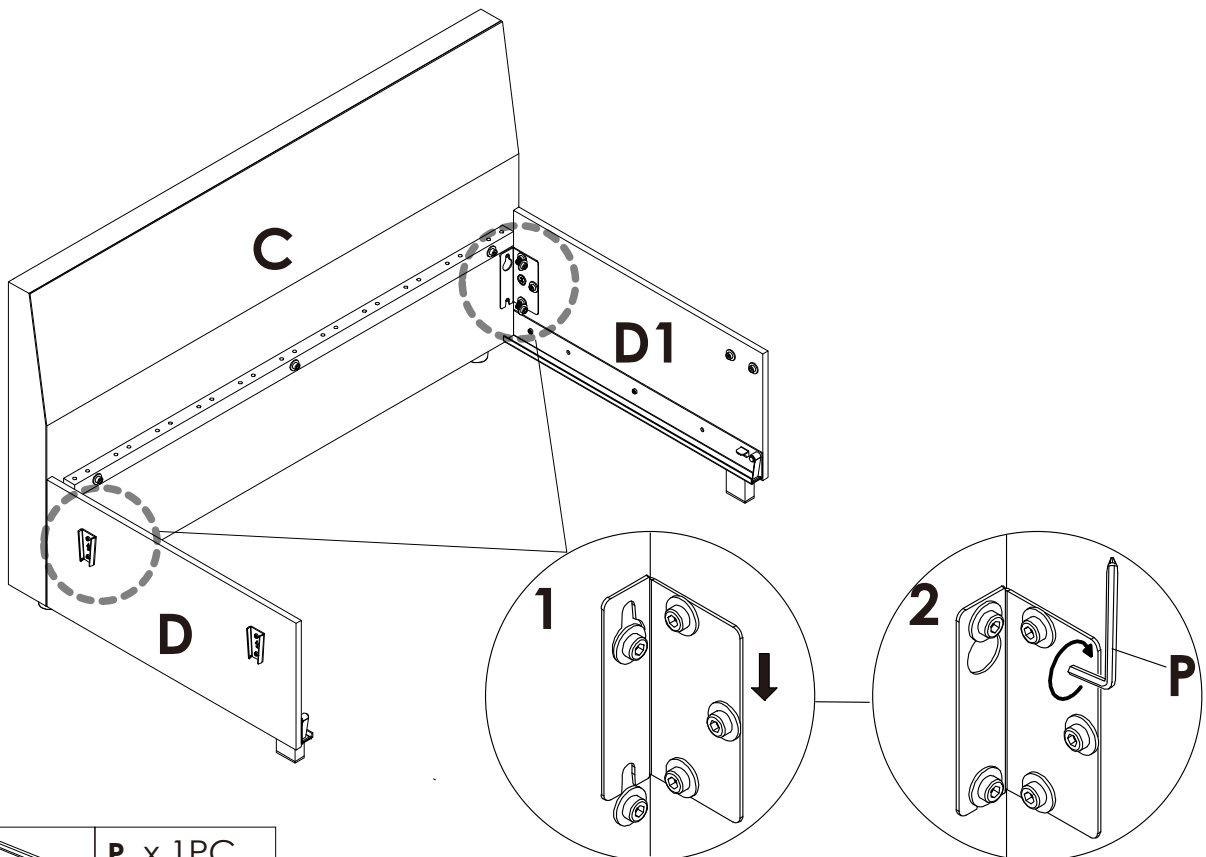

	P x 1PC
---	---------

Assembly Steps(EN)

STEP 19 First, loosen the screws properly for a better fit.

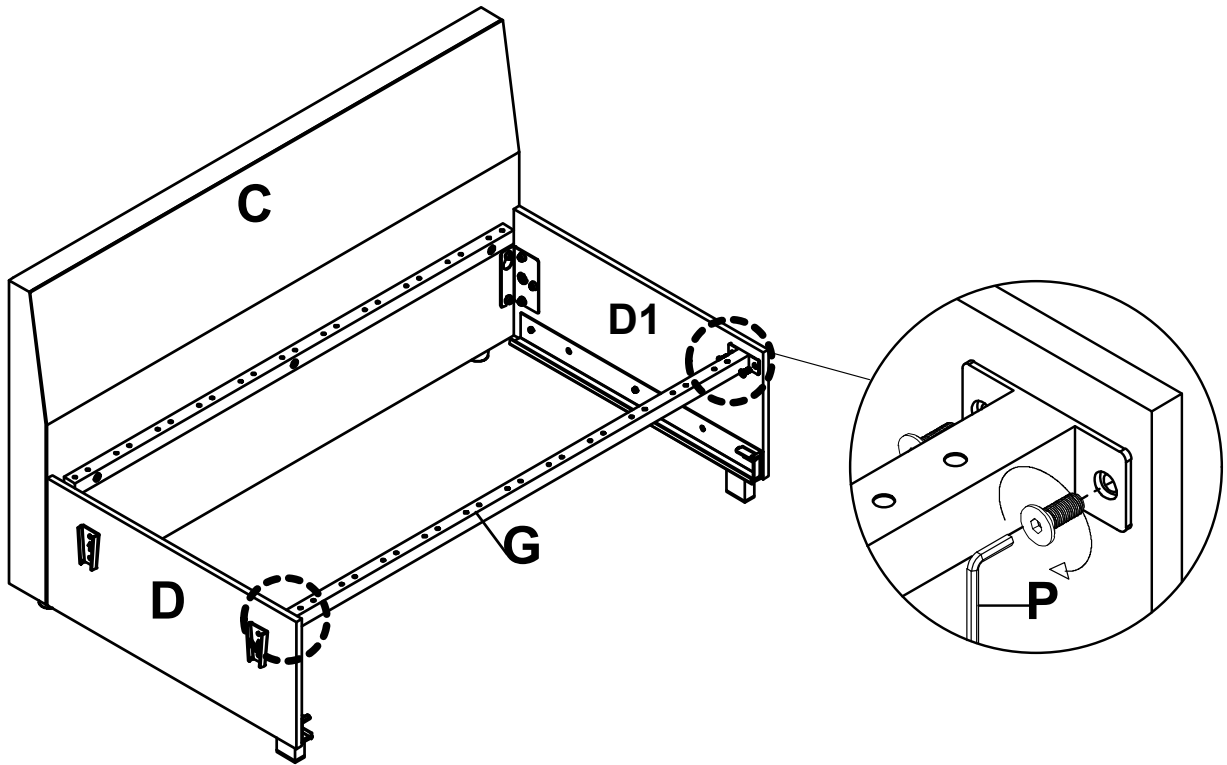

P x 1PC

STEP 20 Place the **B1** in the second position and note that the Velcro side is facing up

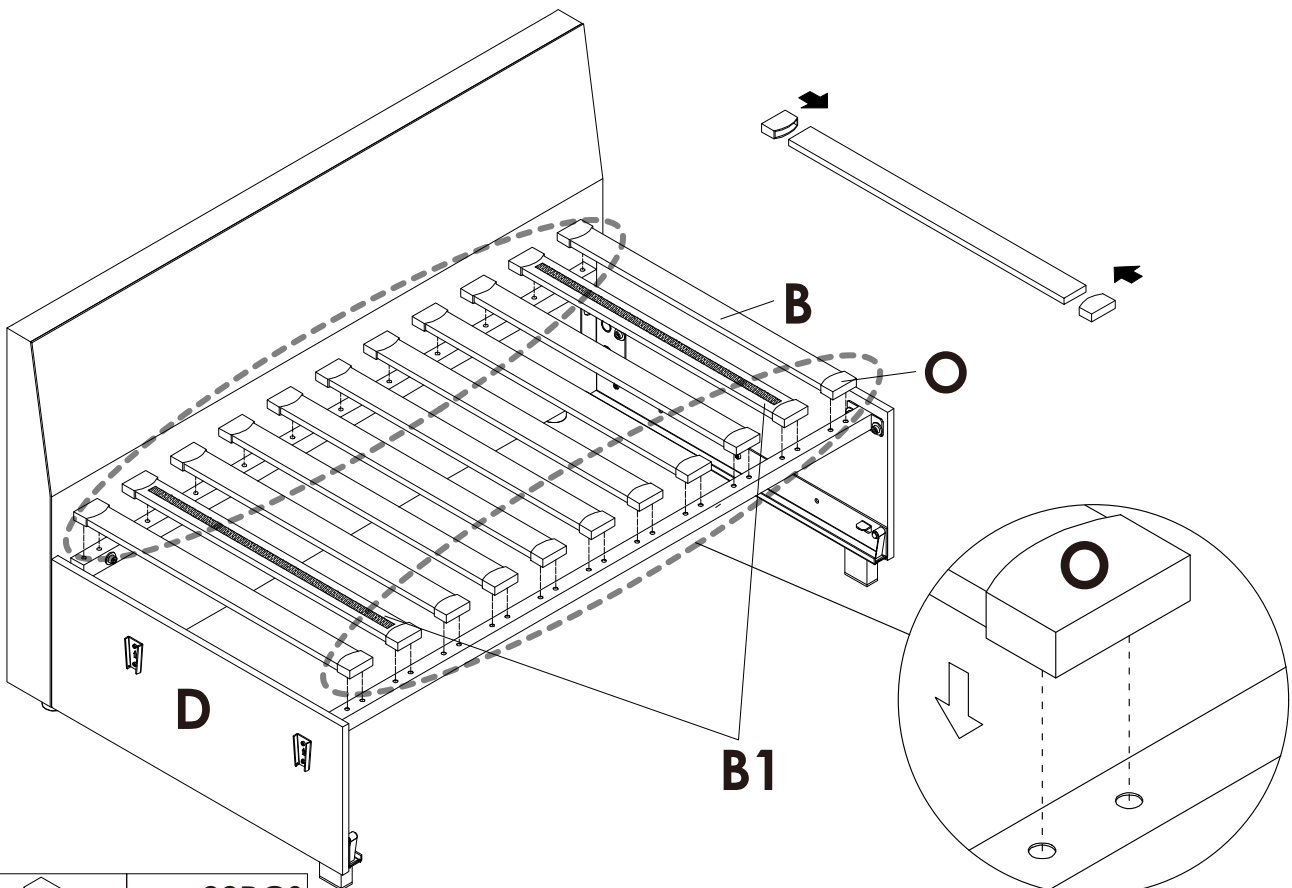

O x 22PCS

Main Structure Accessories

PULL-OUT

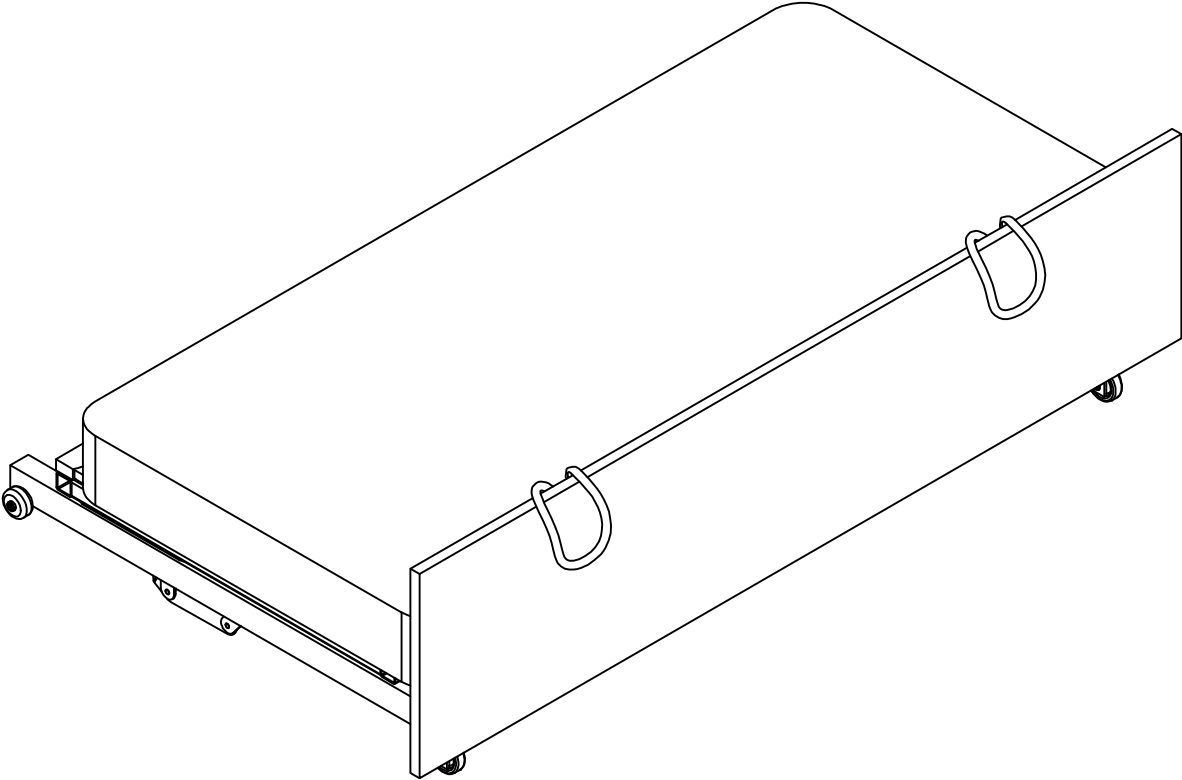
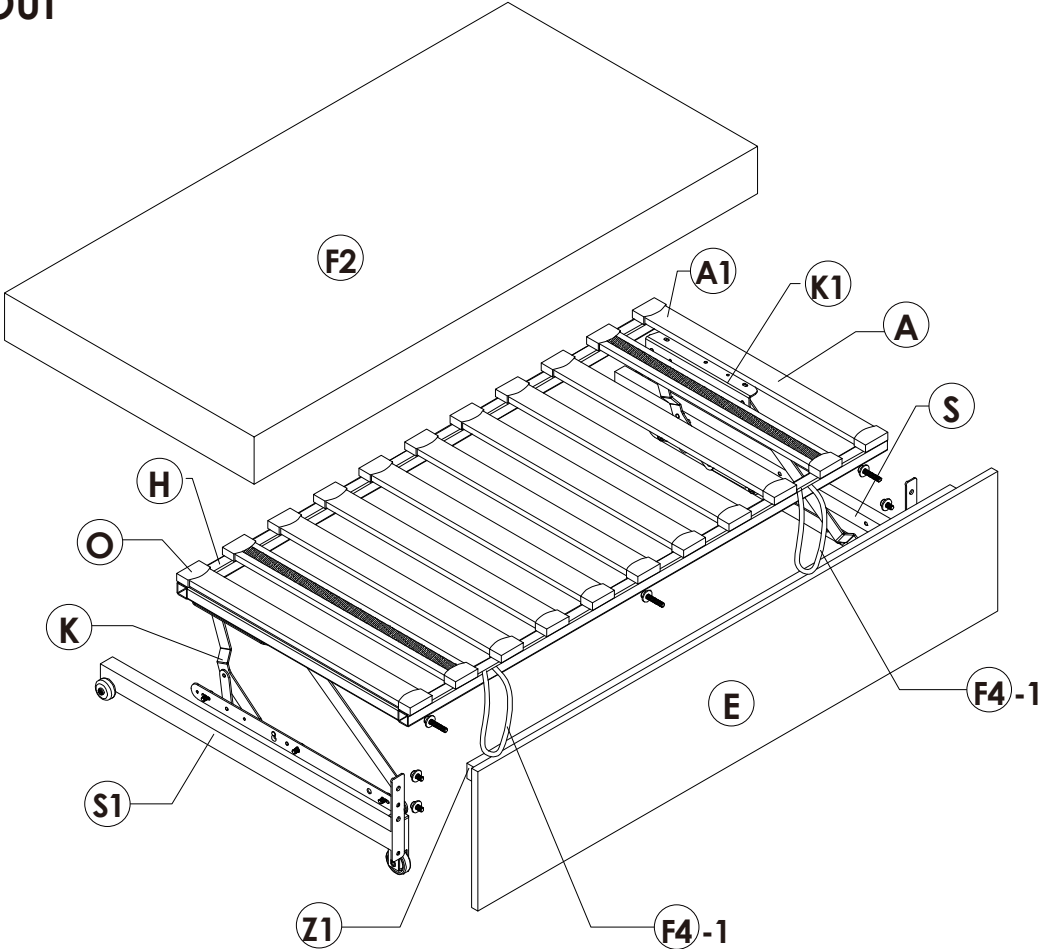

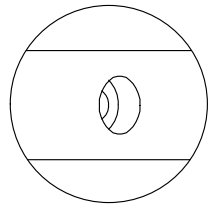

Assembly Steps(EN)

STEP 21

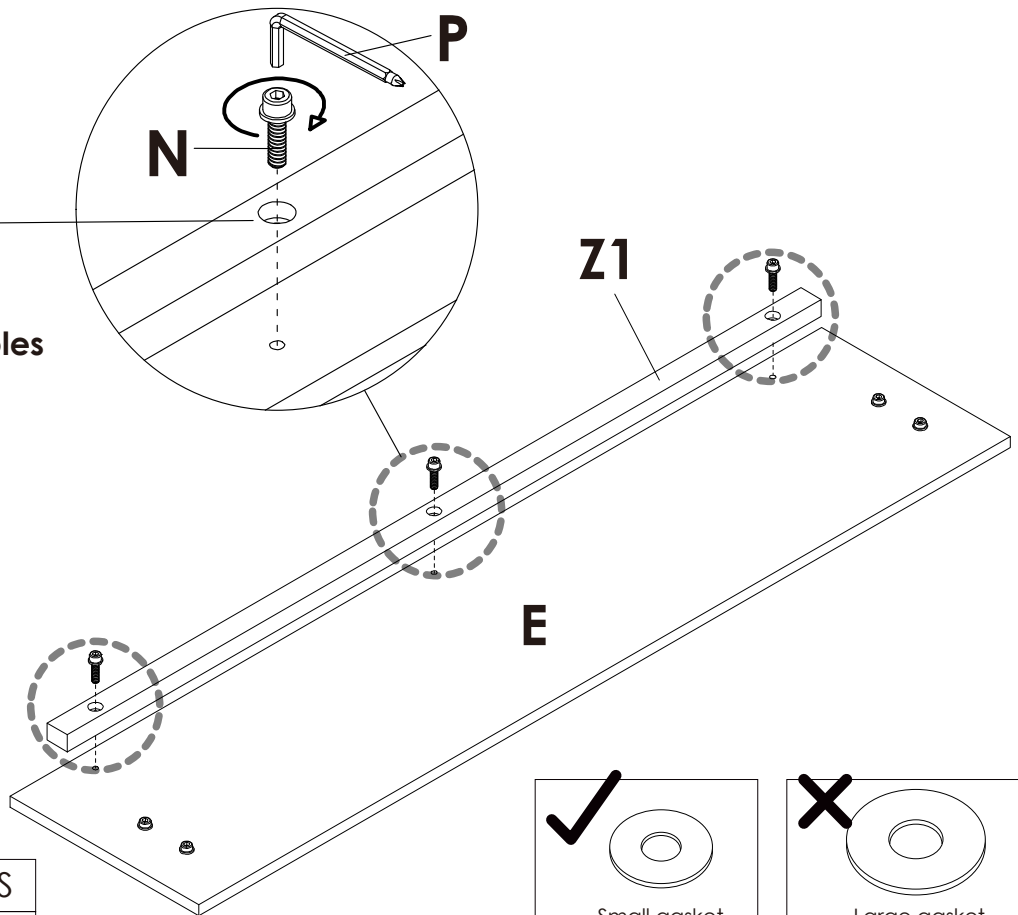

Countersunk holes
face outward.



	N x 3PCS
	P x 1PC

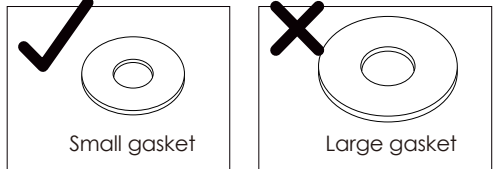

STEP 22

First, loosen the screws properly for a better fit.

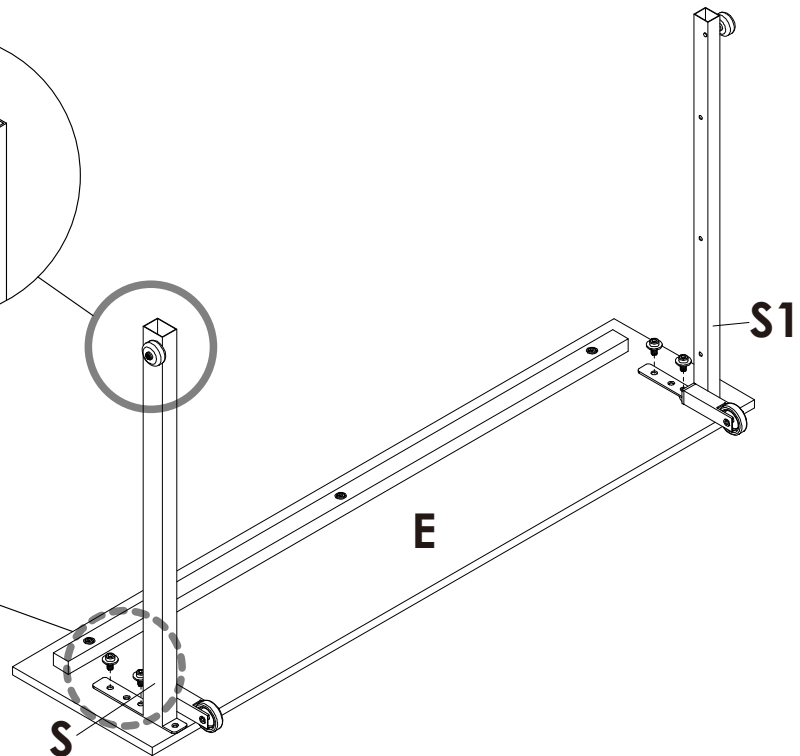
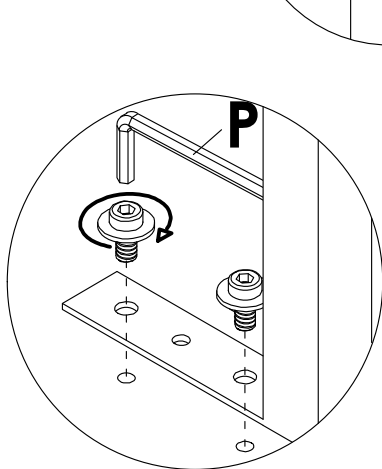
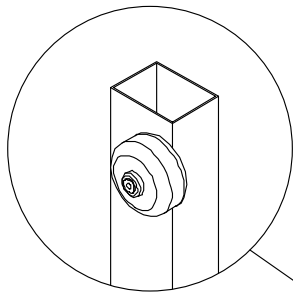



	P x 1PC
---	----------------

Assembly Steps(EN)

STEP 23

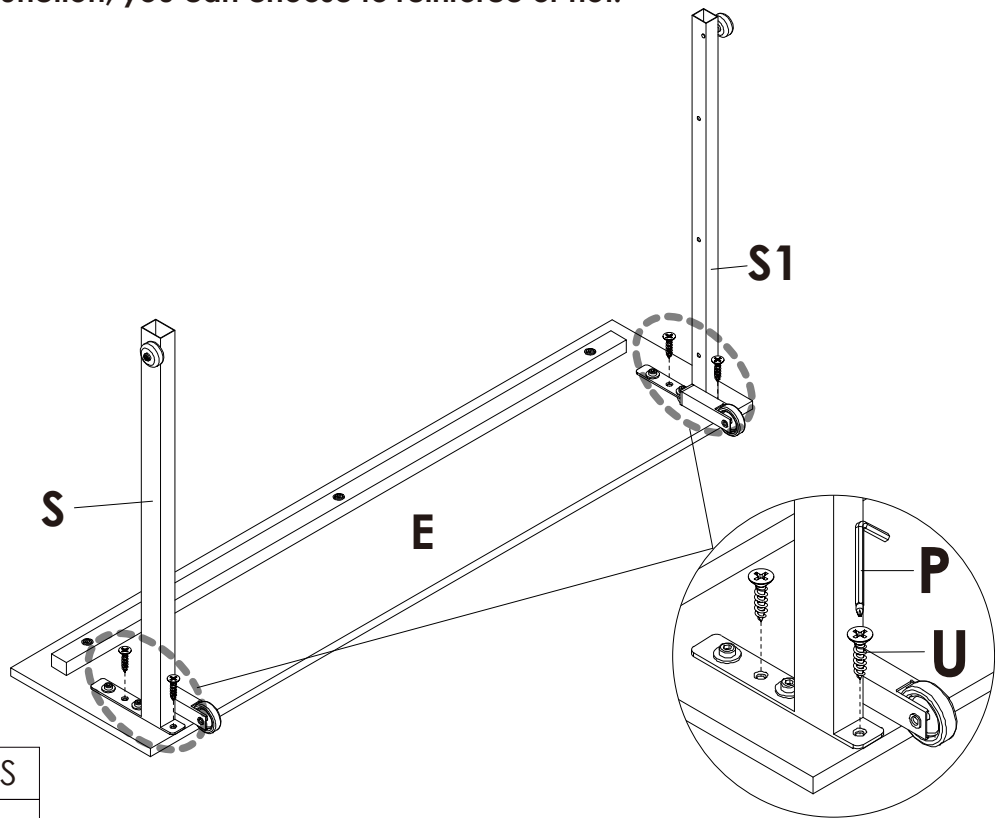

Tips: Self-tapping screw is an auxiliary reinforcement function, you can choose to reinforce or not.

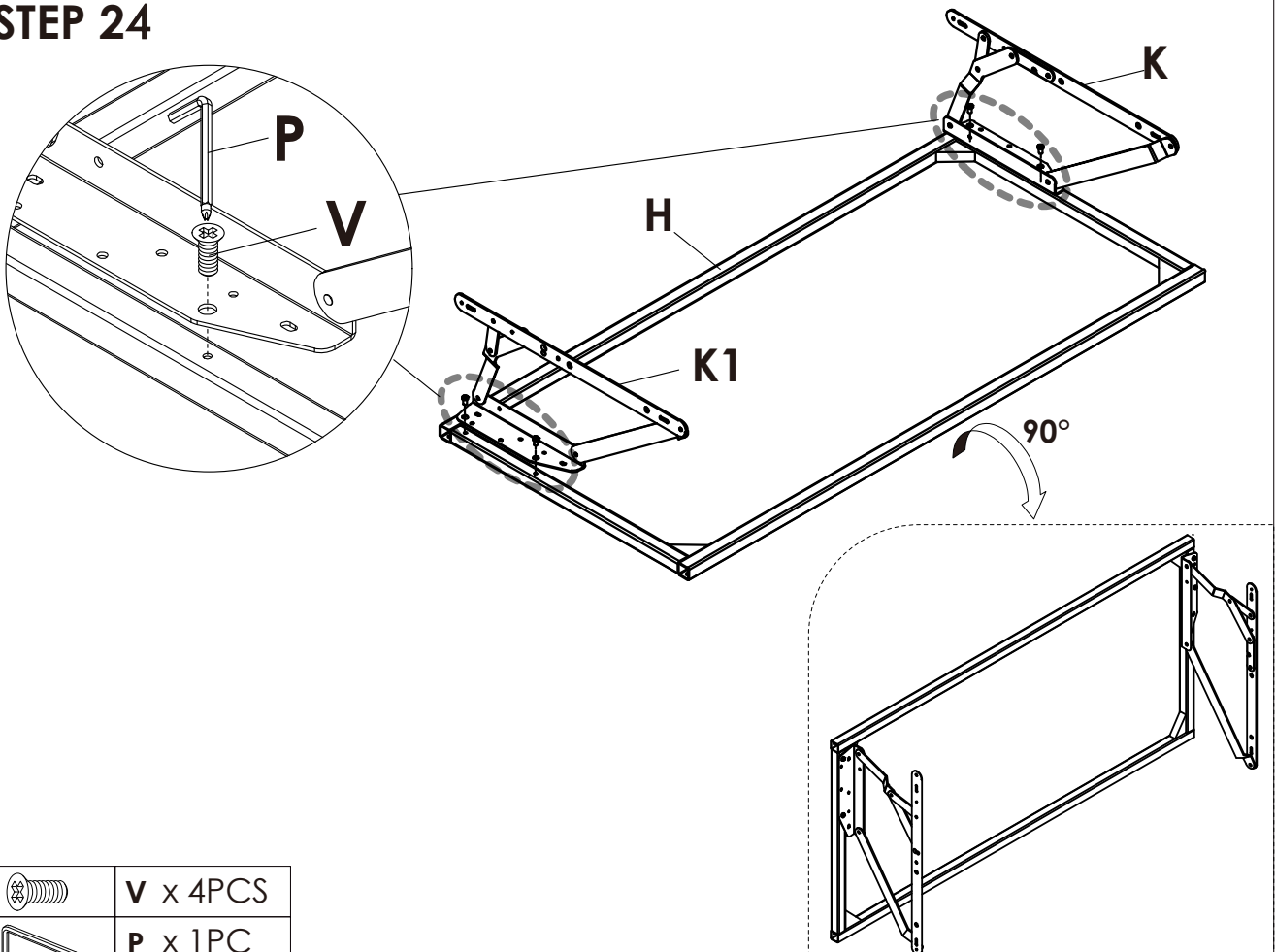

	U x 4PCS
	P x 1PC

STEP 24





	V x 4PCS
	P x 1PC

Assembly Steps(EN)

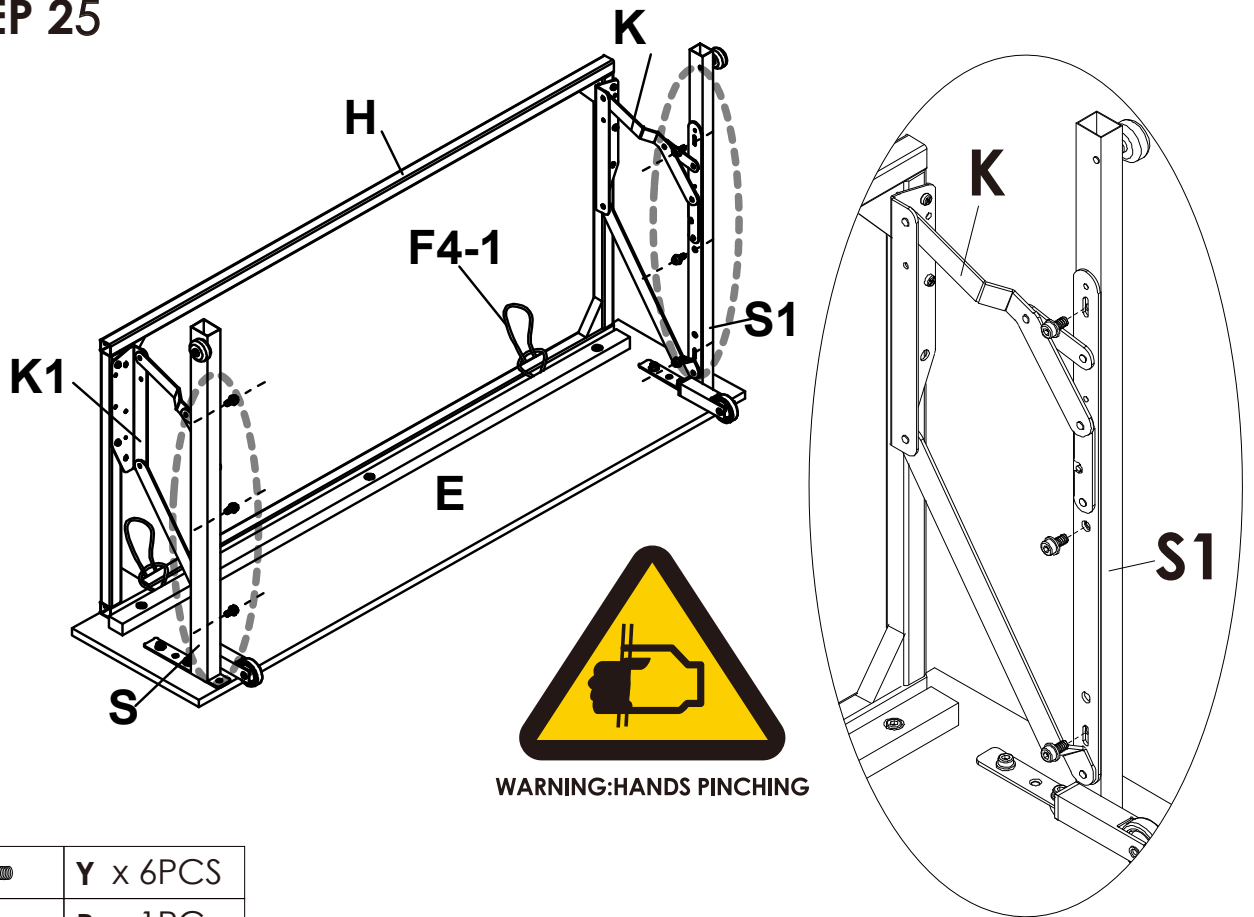
STEP 25



	Y x 6PCS
	P x 1PC

STEP 26

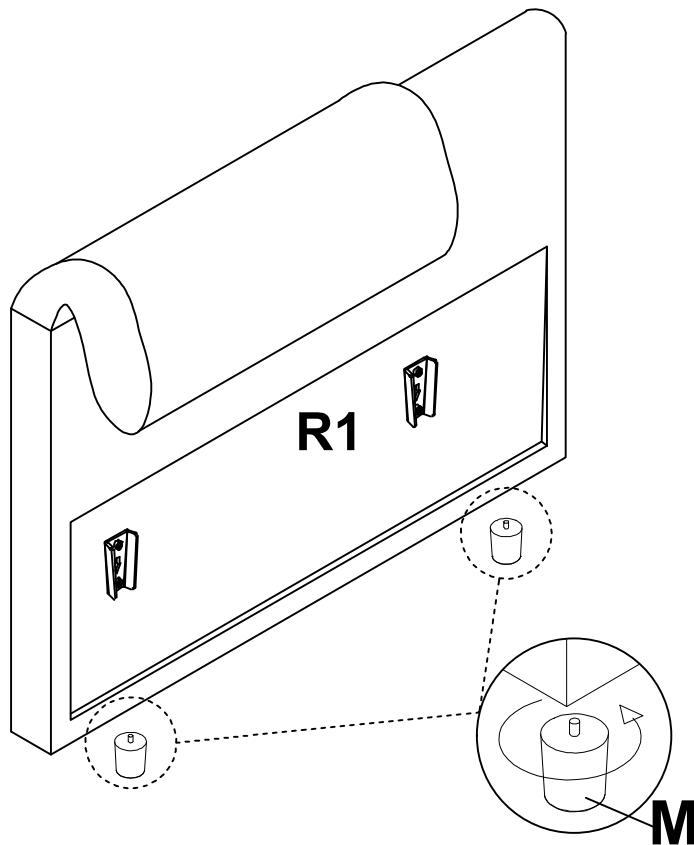

Assembly Steps(EN)

STEP 27

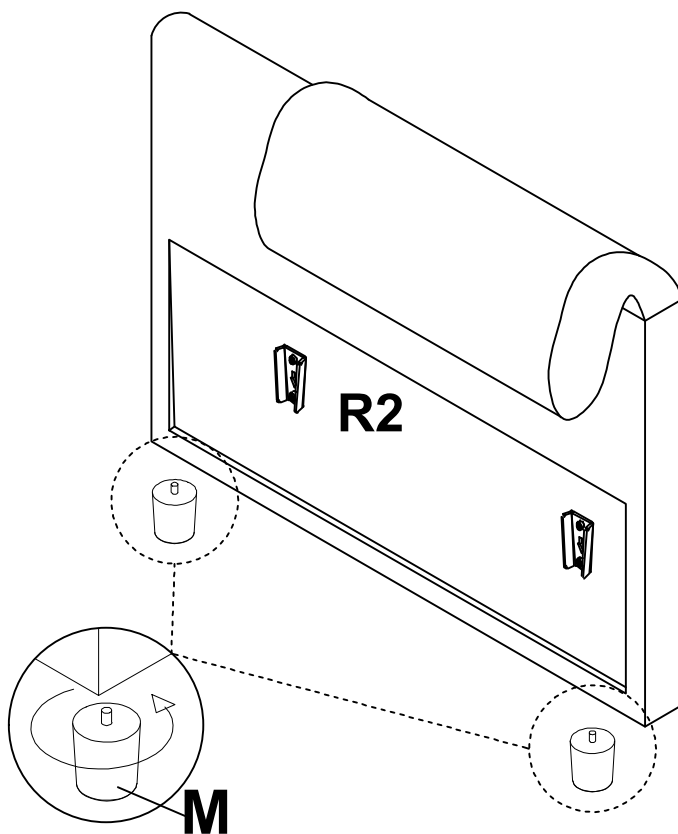

Assembly Option ① STEP 28

It is recommended that two people install it, one person lifts the C board and connects.

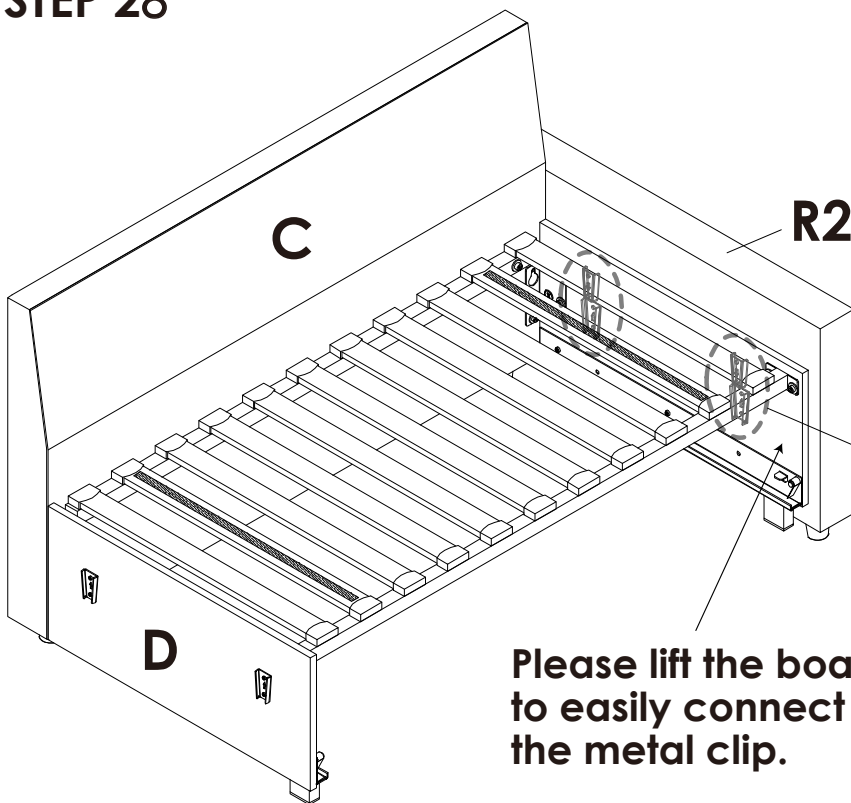

Please lift the board to easily connect the metal clip.

Assembly Steps(EN)

Assembly Option ① STEP 29

Please lift the board to easily connect the metal clip.

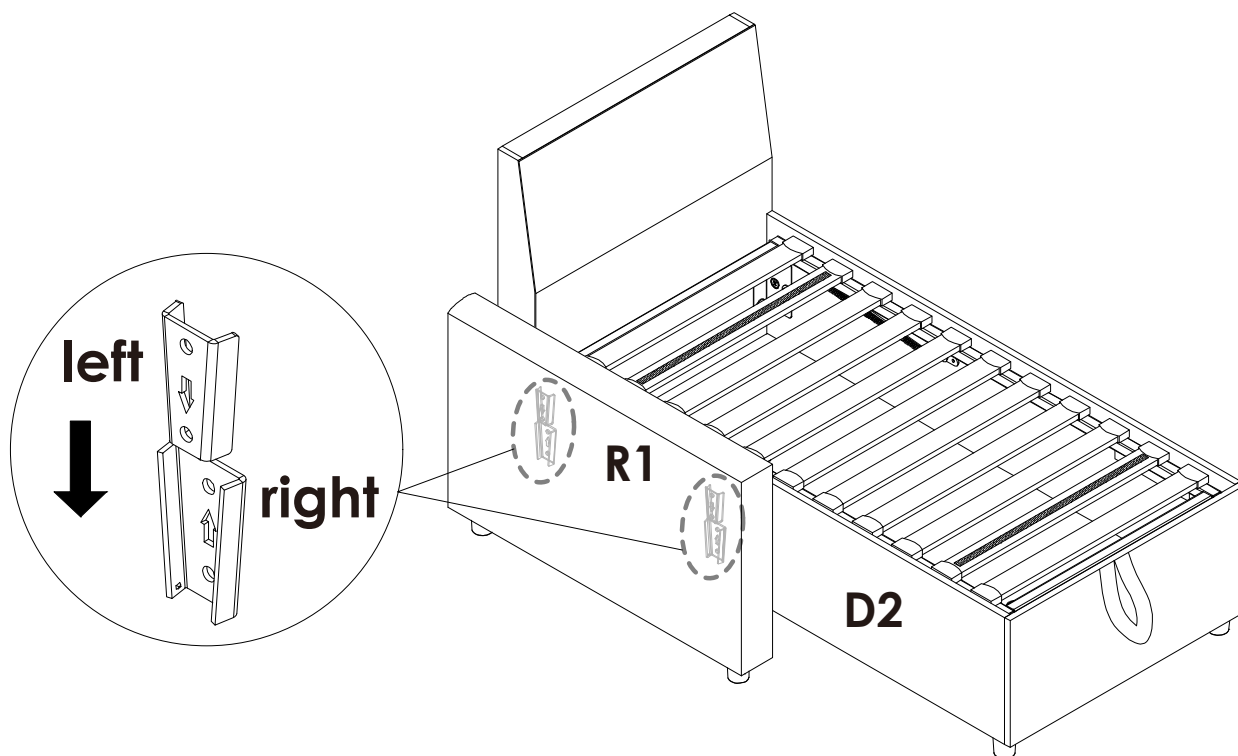

Assembly Option ① STEP 30

Please lift the board to easily connect the metal clip.

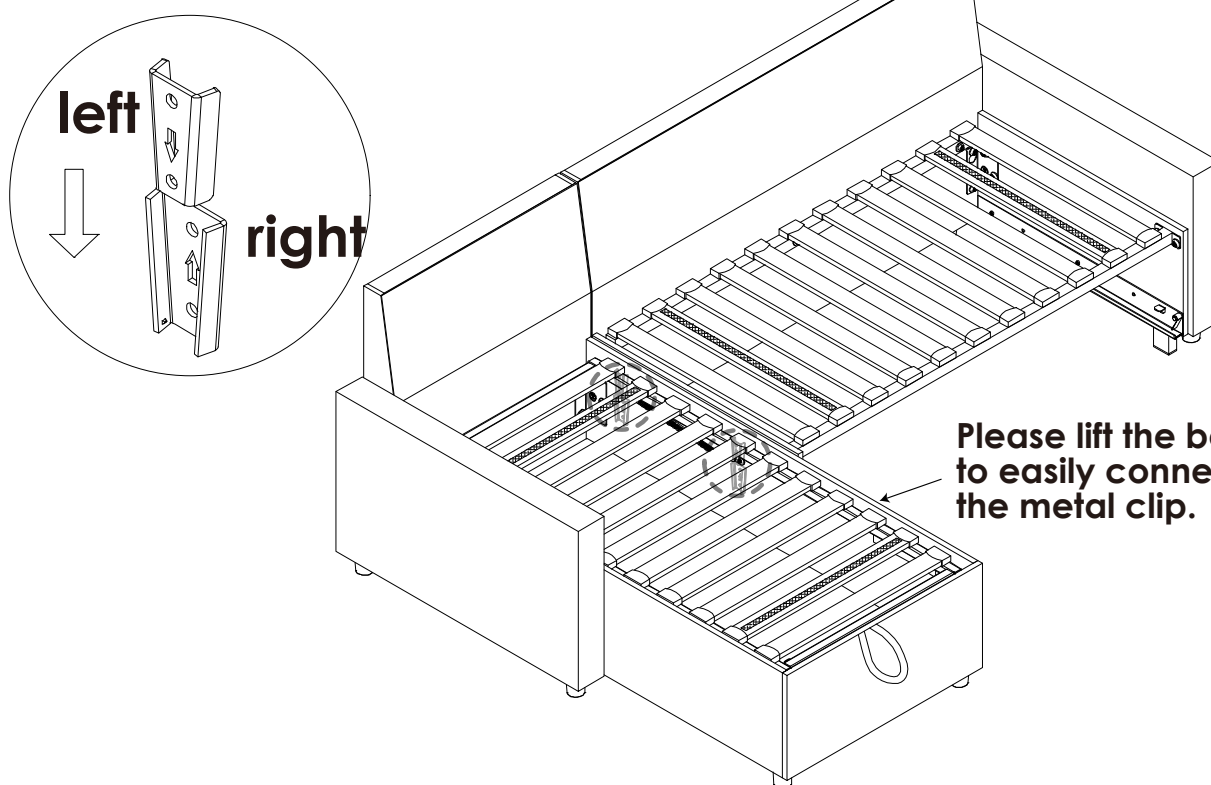

Assembly Steps(EN)

Assembly Option ①

STEP 31

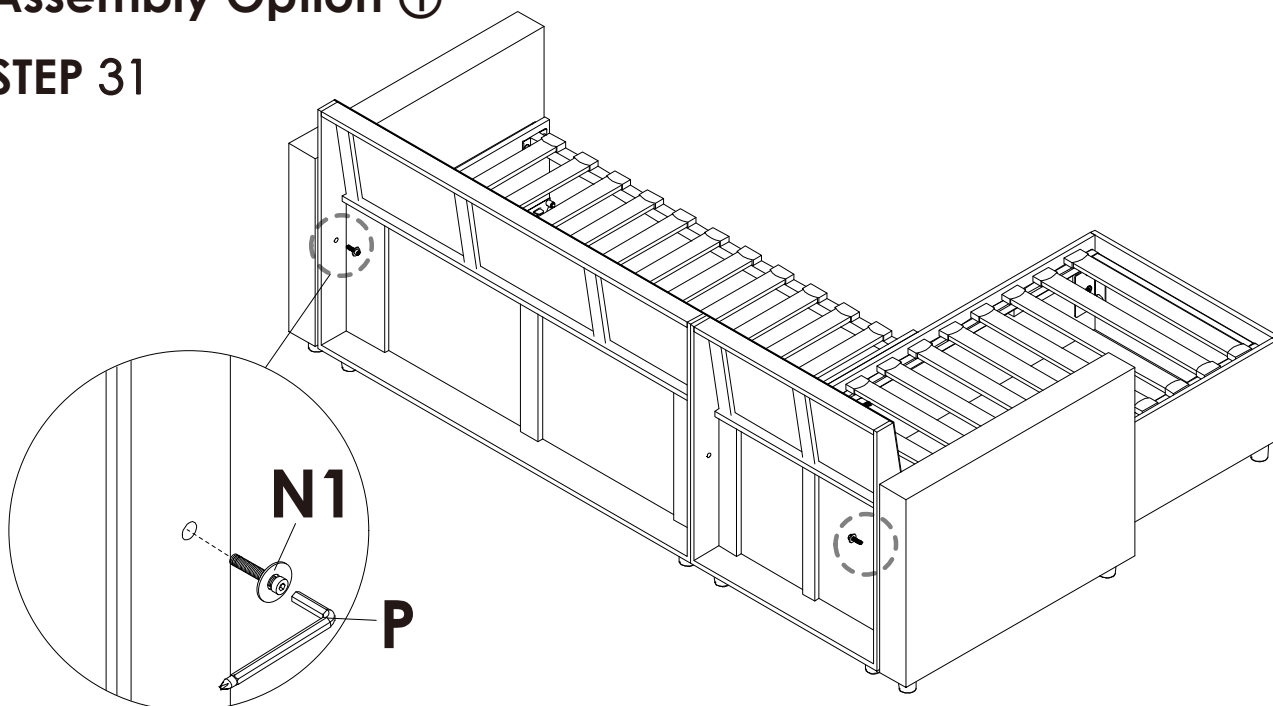

Secure with locking screws

	N1 x 2PCS
	P x 1PC

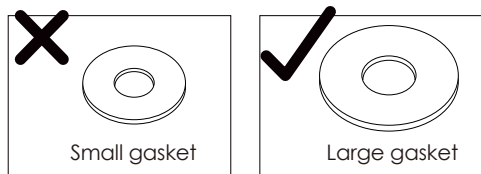

Assembly Option ①

STEP 32

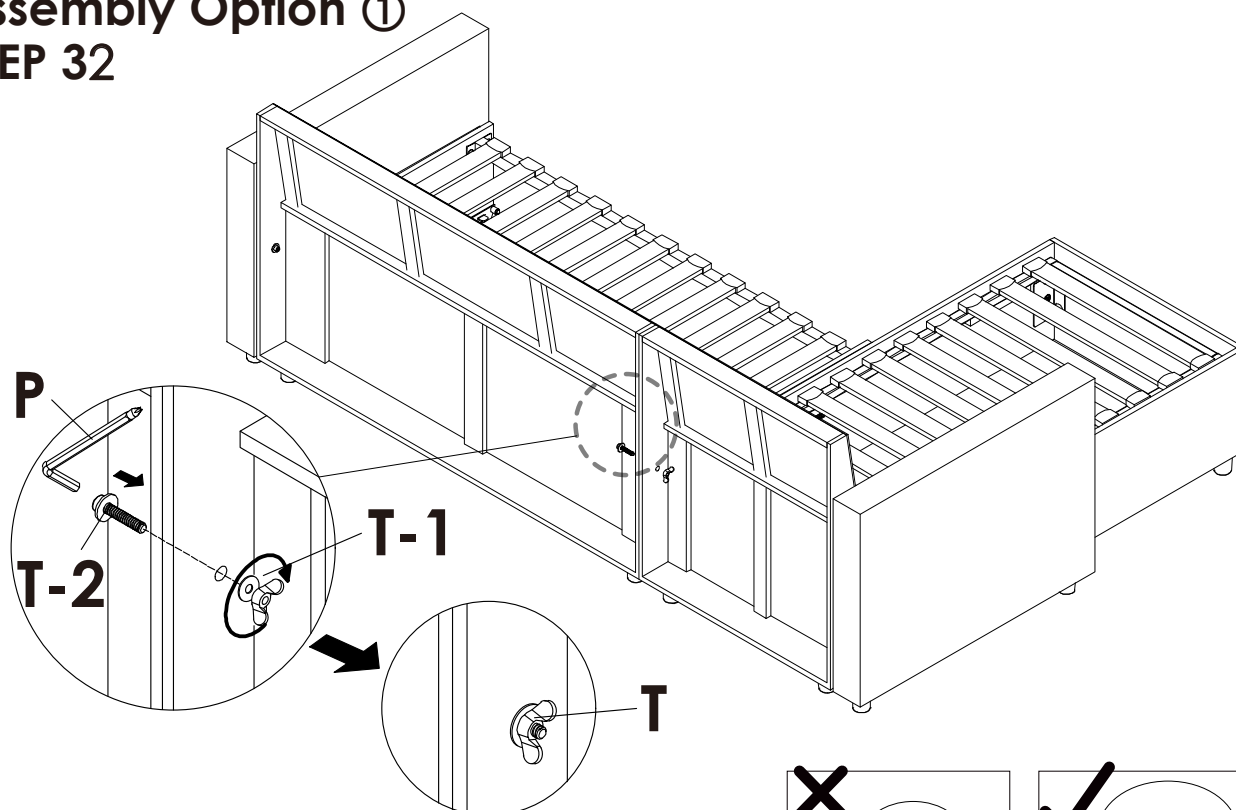

Screw through hole and tighten with butterfly nut.

	P x 1PC
	T x 1PC

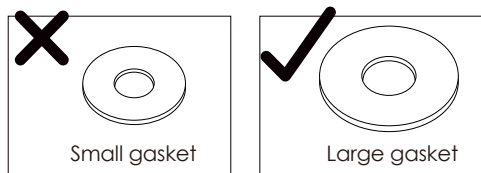

Assembly Steps(EN)

Assembly Option ①

STEP 33

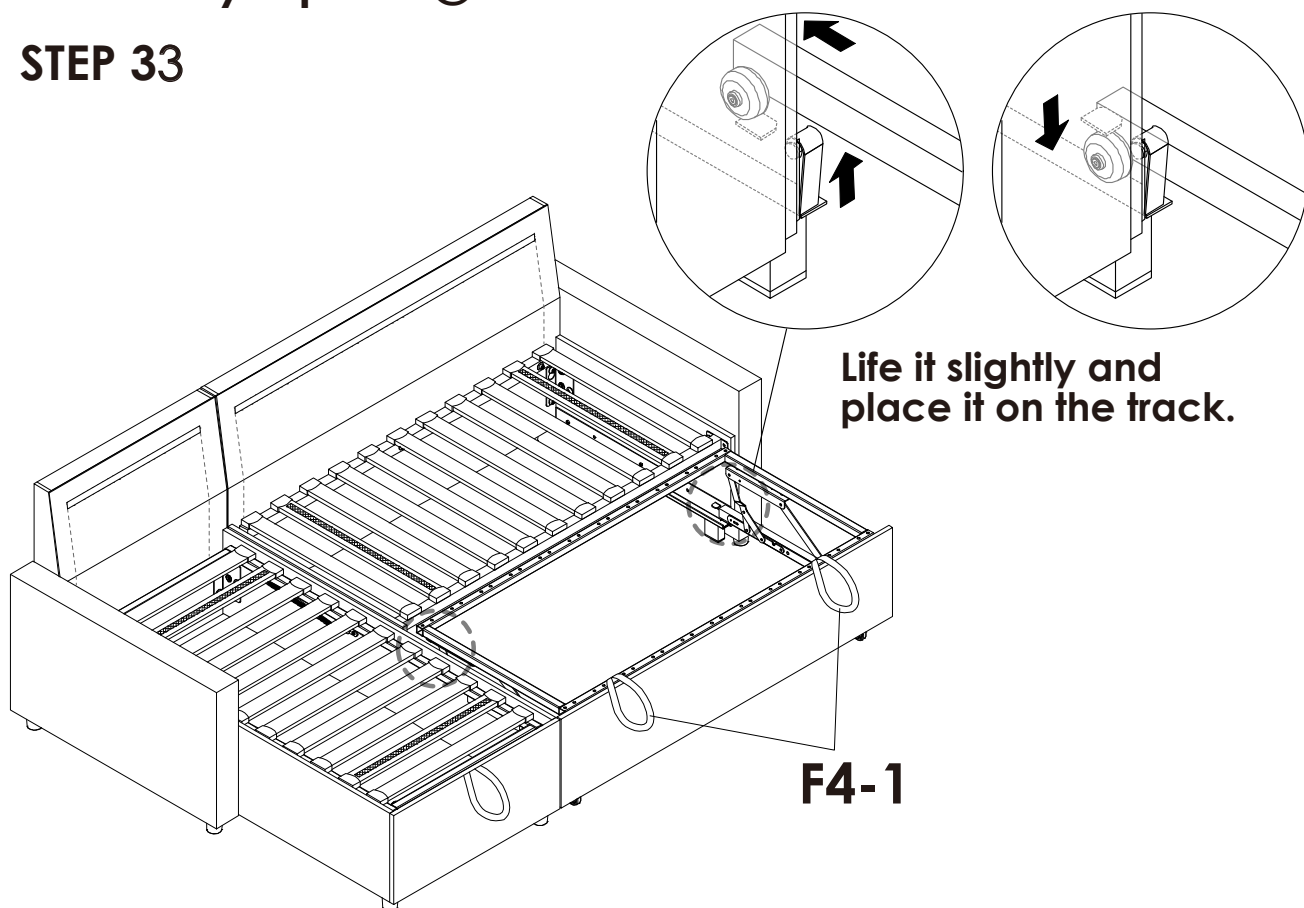

Assembly Option ①

STEP 34

Place the A1 in the second position and note that the Nylon Fastener side is facing up.

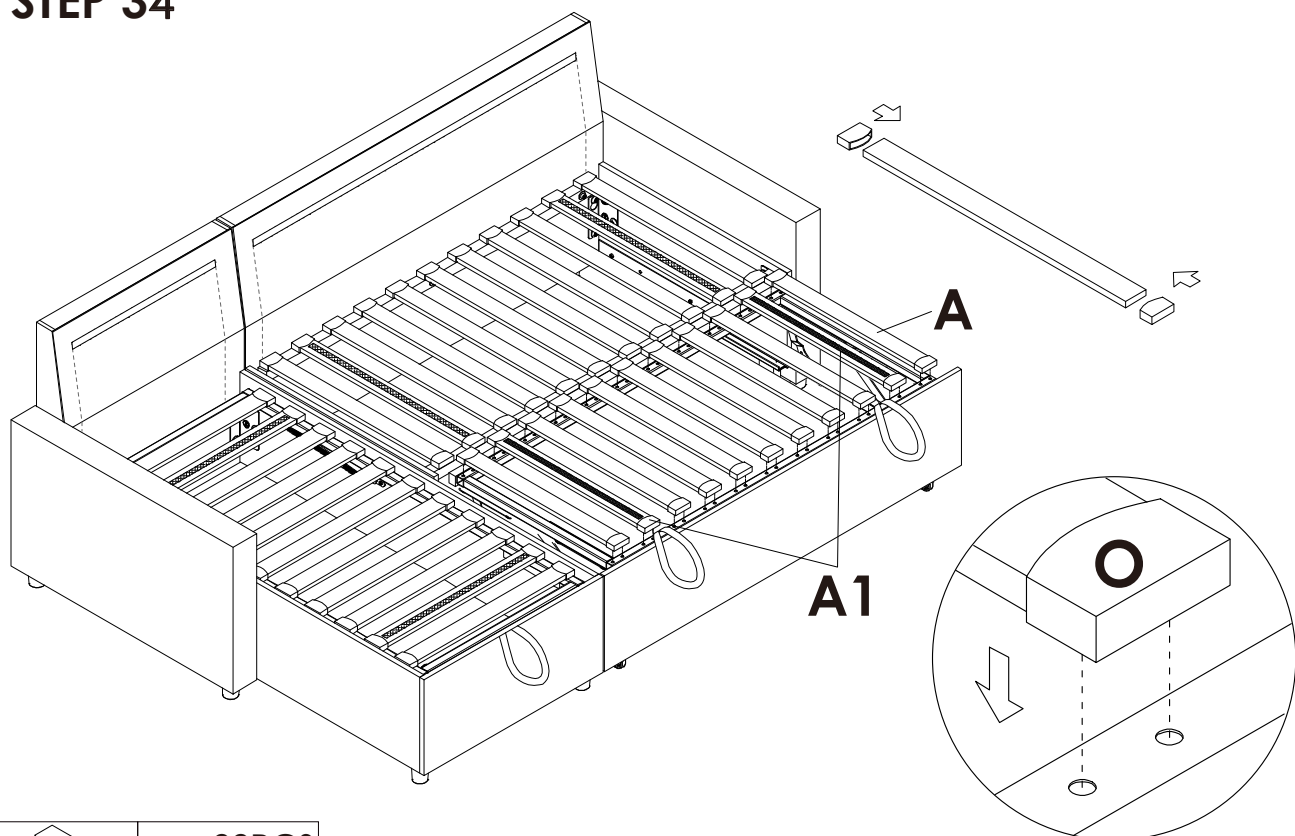

○ x 22PCS

Assembly Steps(EN)

Assembly Option ①

STEP 35

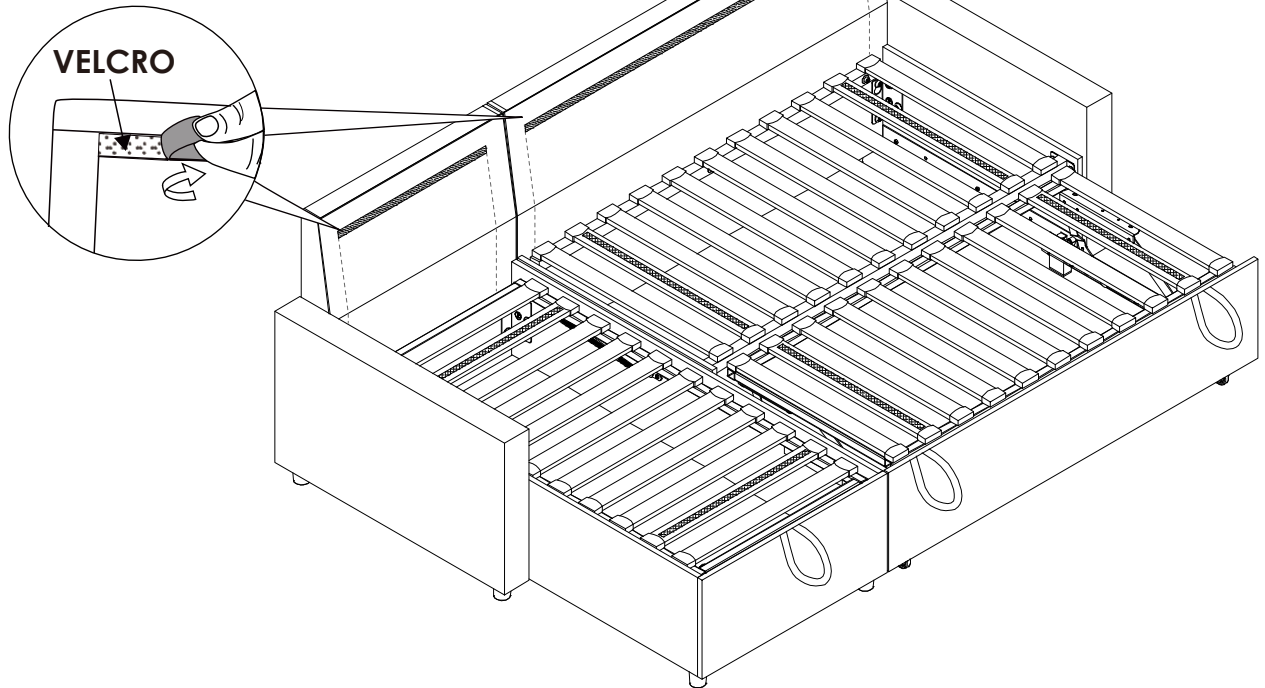

Assembly Option ①

STEP 36

If there is a slight bulge when you lift the F2 and then put it down for the first time, it is recommended that you adjust the position of the F2 or press it from both sides.

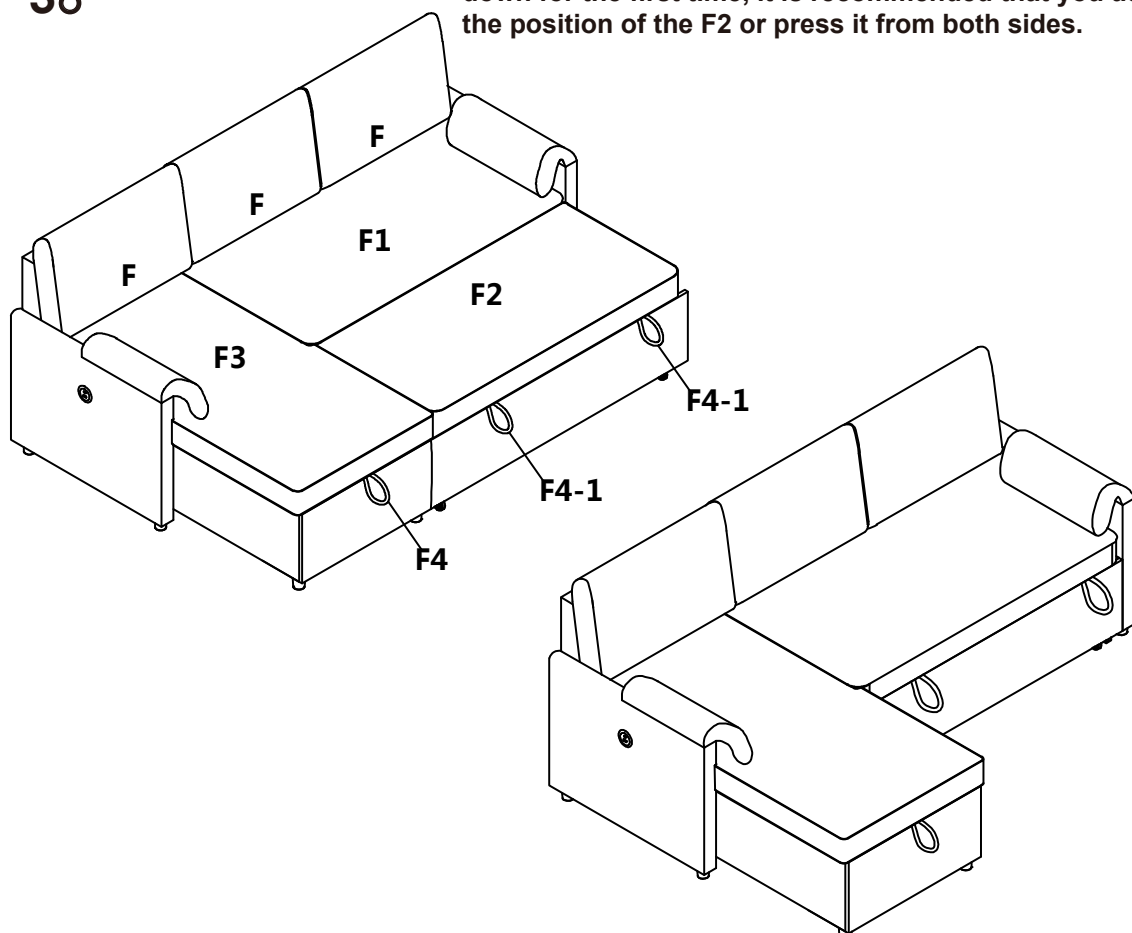

Assembly Steps(EN)

Assembly Option ② STEP 28

Please lift the board to easily connect the metal clip.

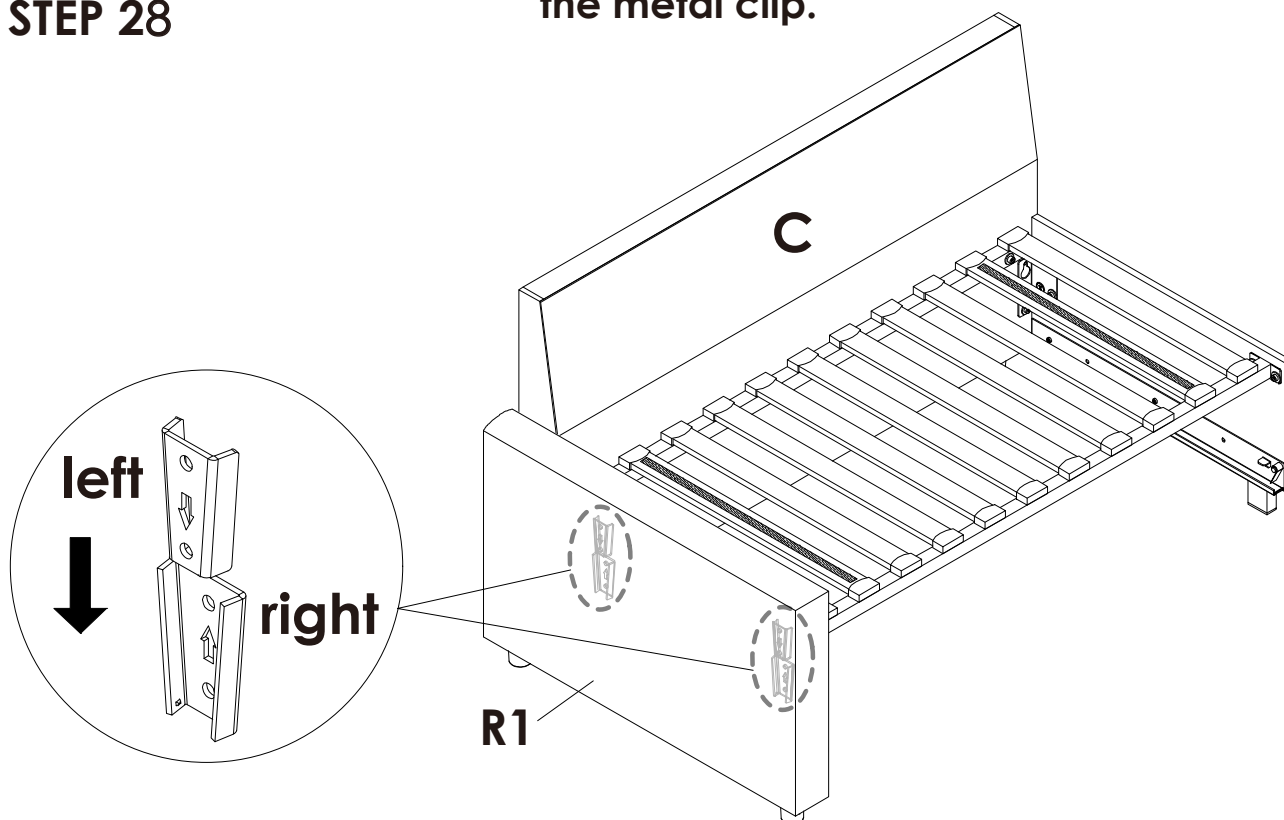

Assembly Option ② STEP 29

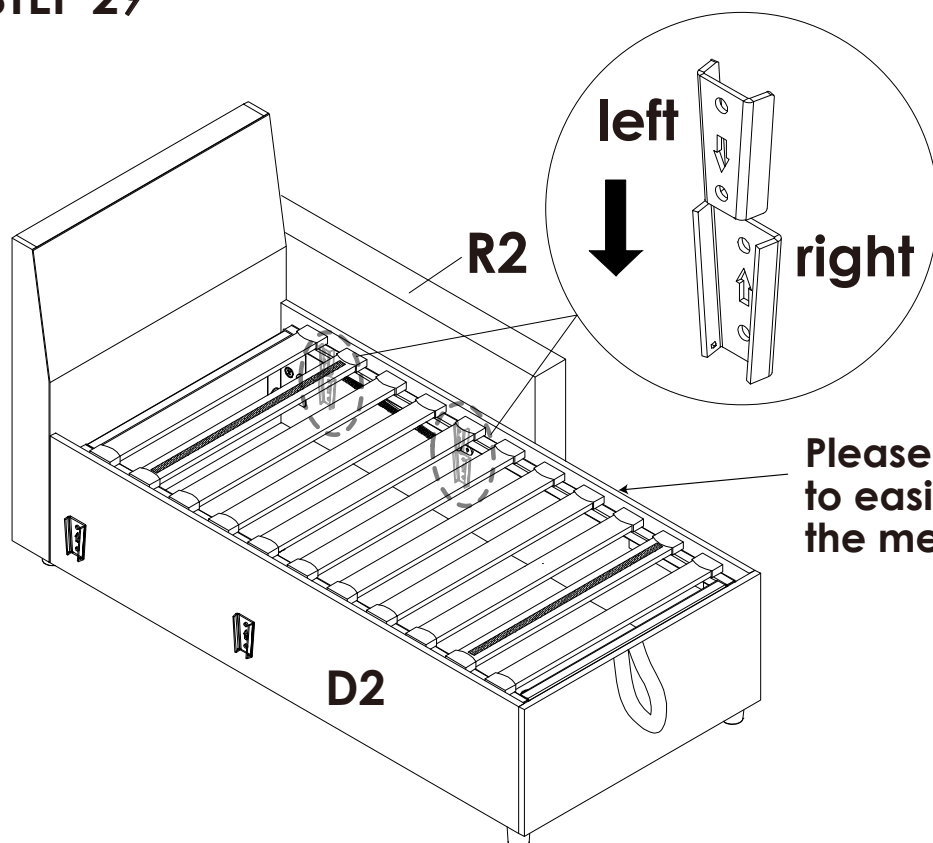

Please lift the board to easily connect the metal clip.

Assembly Steps(EN)

Assembly Option ②

STEP 30

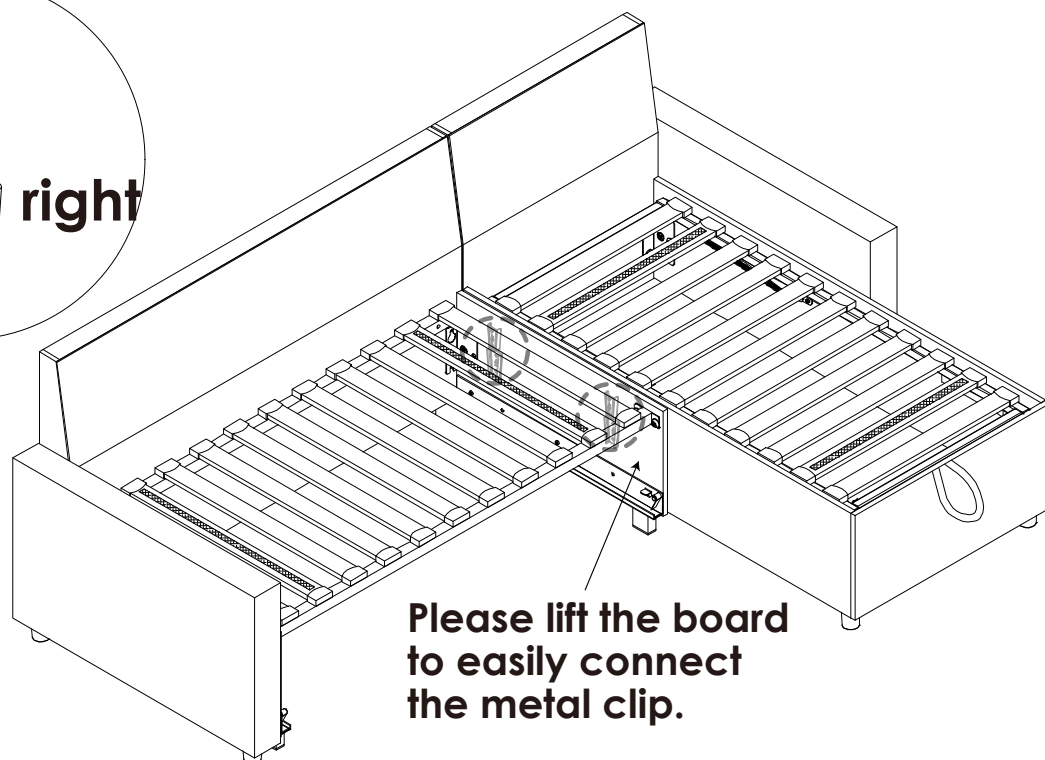
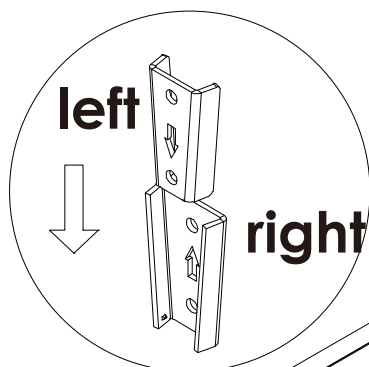

Assembly Option ②

STEP 31

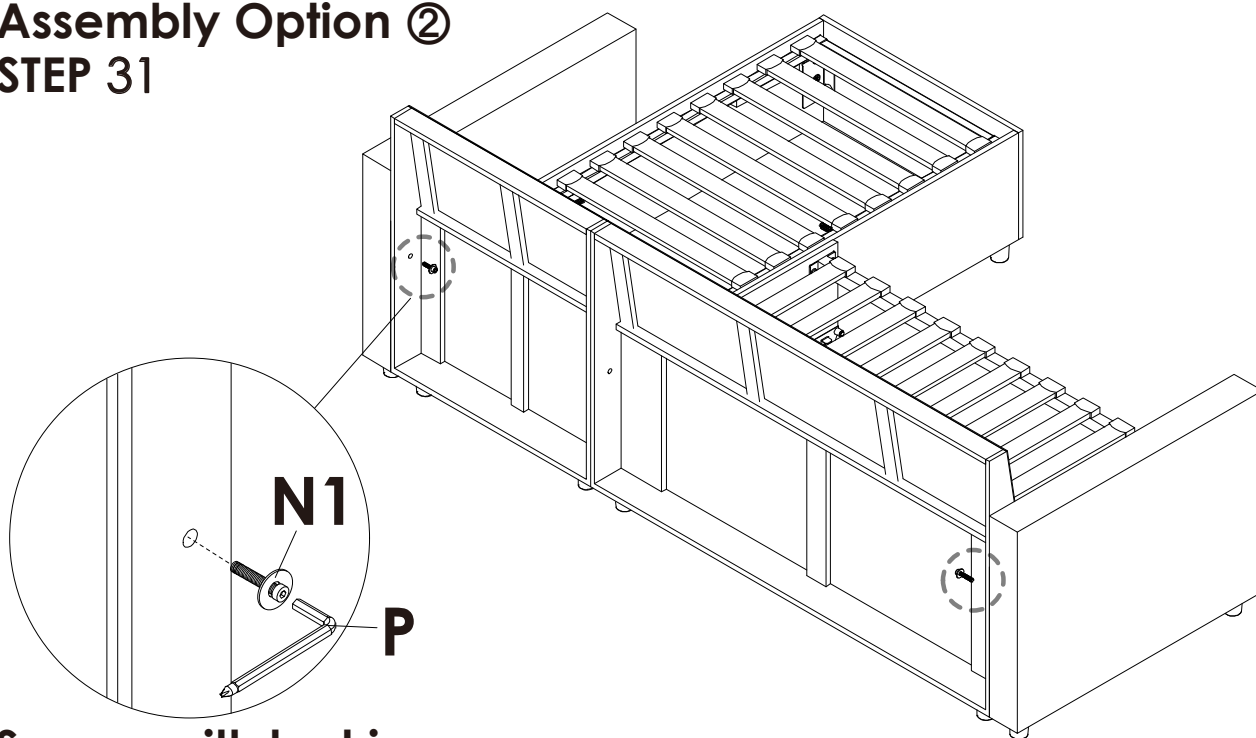

Secure with locking screws

	N1 x 2PCS
	P x 1PC

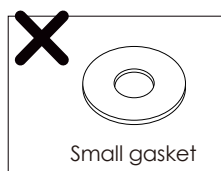



Assembly Steps(EN)

Assembly Option ②

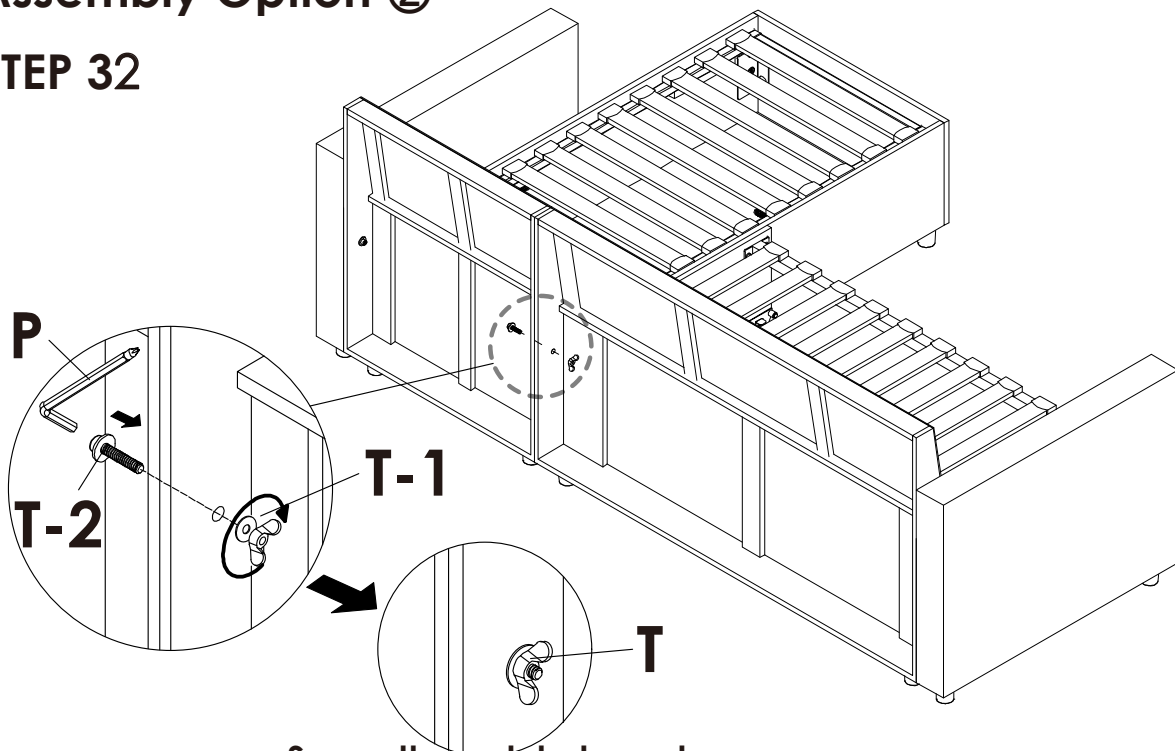
STEP 32



Screw through hole and tighten with butterfly nut.

	P x 1PC
	T x 1PC

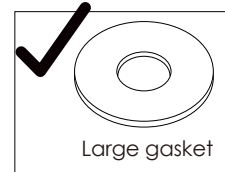
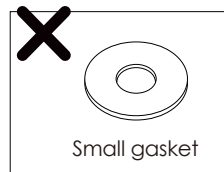

Assembly Option ②

STEP 33

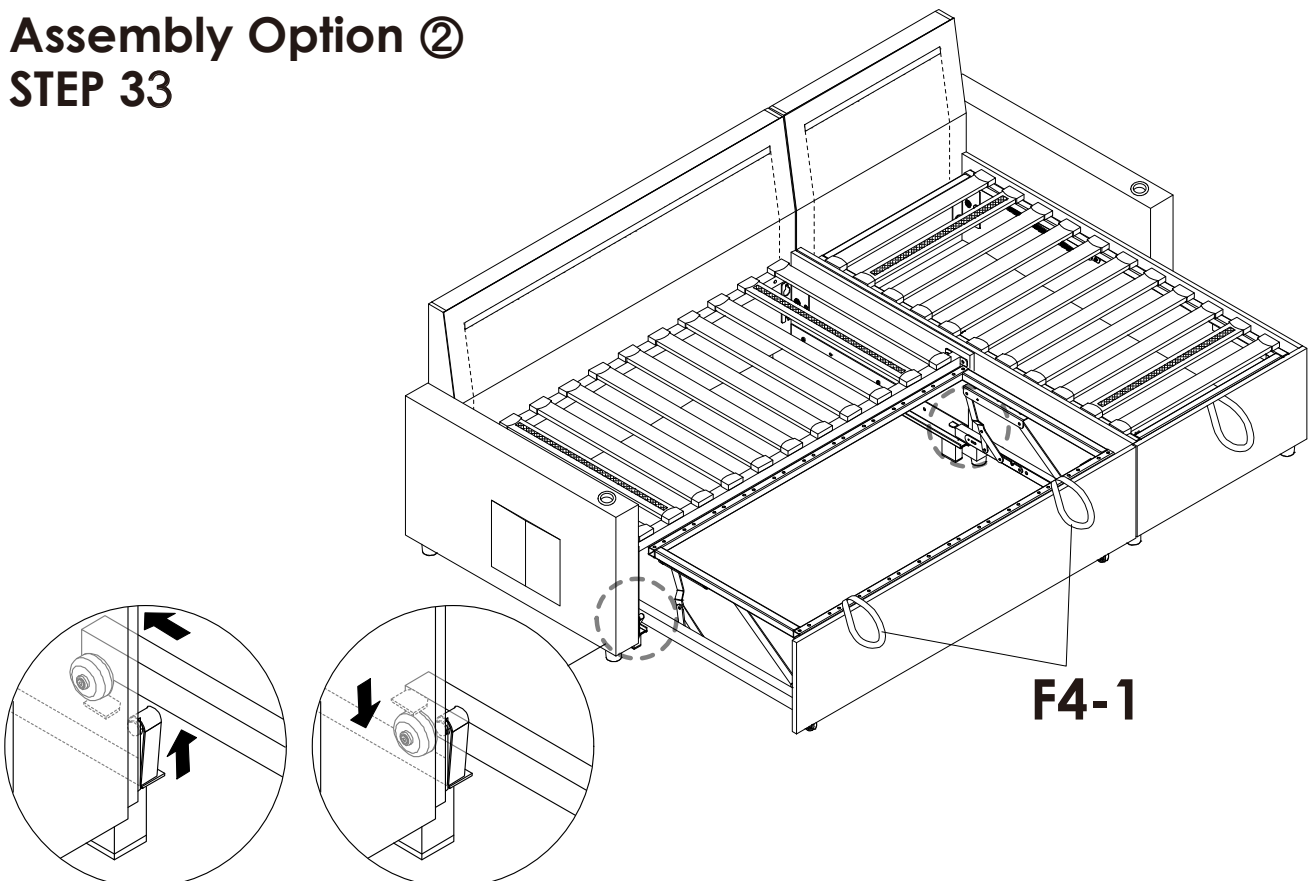

Life it slightly and place it on the track.

Assembly Steps(EN)

Assembly Option ②

STEP 34

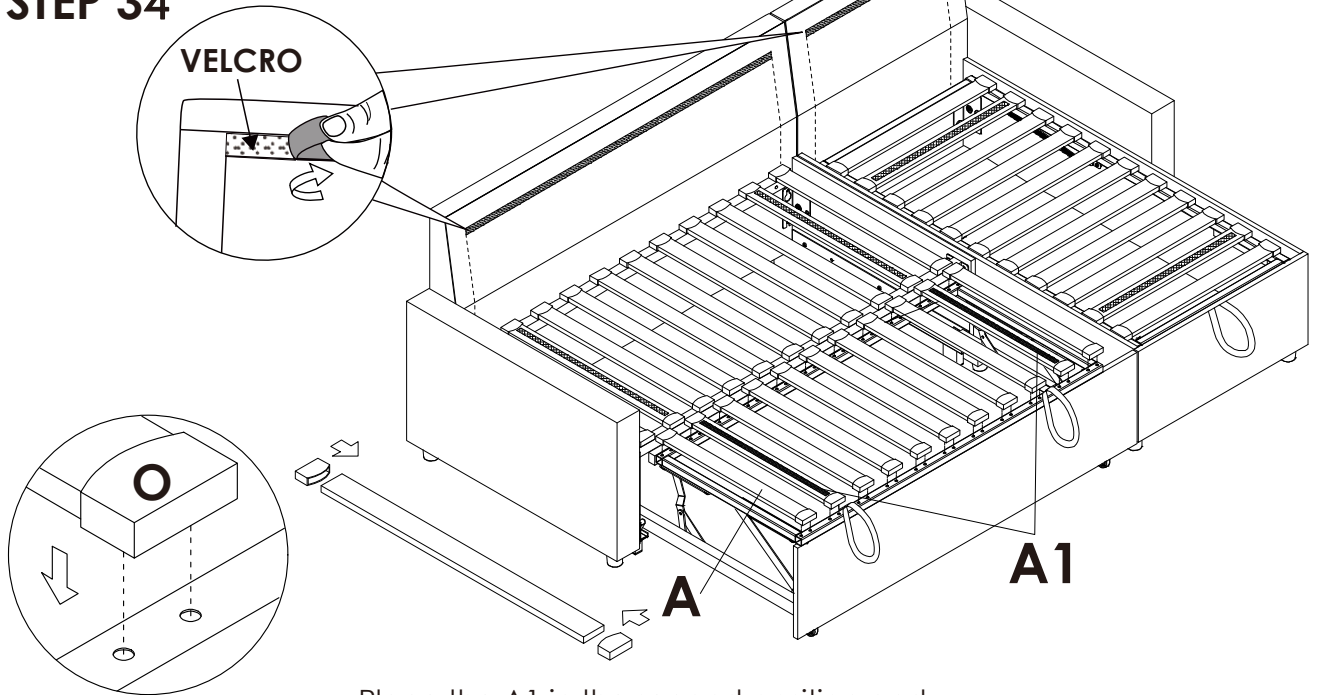

○ x 22PCS

Assembly Option ②

STEP 35

