

# ASSEMBLY INSTRUCTION

## MODEL : SIDE TABLE

Before you begin, please follow Assembly Instruction carefully. Follow them step by step.

### STEP 5

 (A) M6 X 40MM JCBC SCREW - 4 PCS

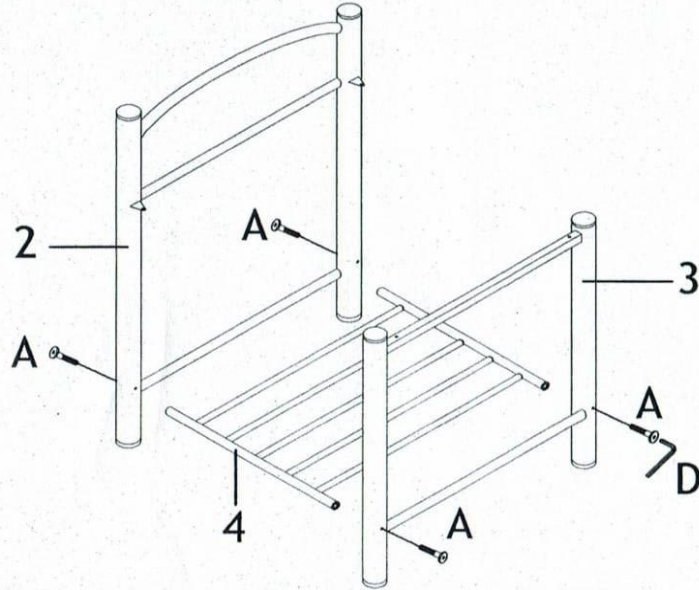

 (D) M4 ALLEN KEY - 1 PC

REQUIRED ASSEMBLY TOOLS :  
POZI SCREWDRIVER - 1PC

 (B) M4 X 16MM CSK SCREW - 2 PCS

 (C) M4 X 32MM CSK SCREW - 2 PCS

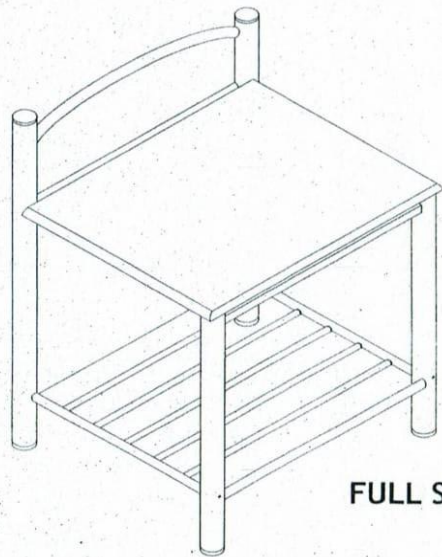
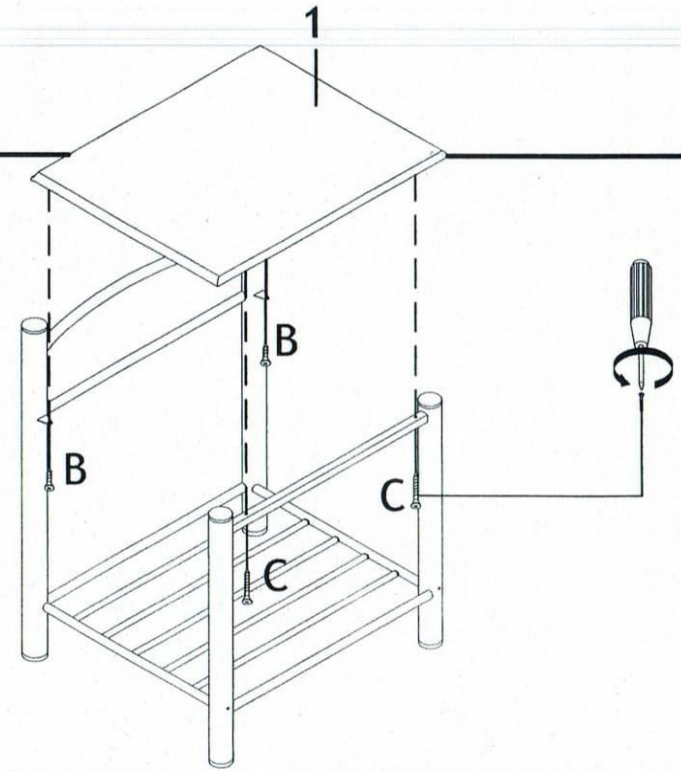

FULL SETUP

### HARDWARE LIST

 (A) M4 X 32MM CSK SCREW - 2 PCS

 (B) M4 X 16MM CSK SCREW - 2 PCS

 (C) M6 X 40MM JCBC SCREW - 4 PCS

 (D) M4 ALLEN KEY - 1 PC

### PART LIST

 (1) TABLE TOP X 1 PC

 (2) SIDE TABLE A X 1 PC

 (3) SIDE TABLE B X 1 PC

 (4) PART 1