

Assembly instructions

Montageanleitung

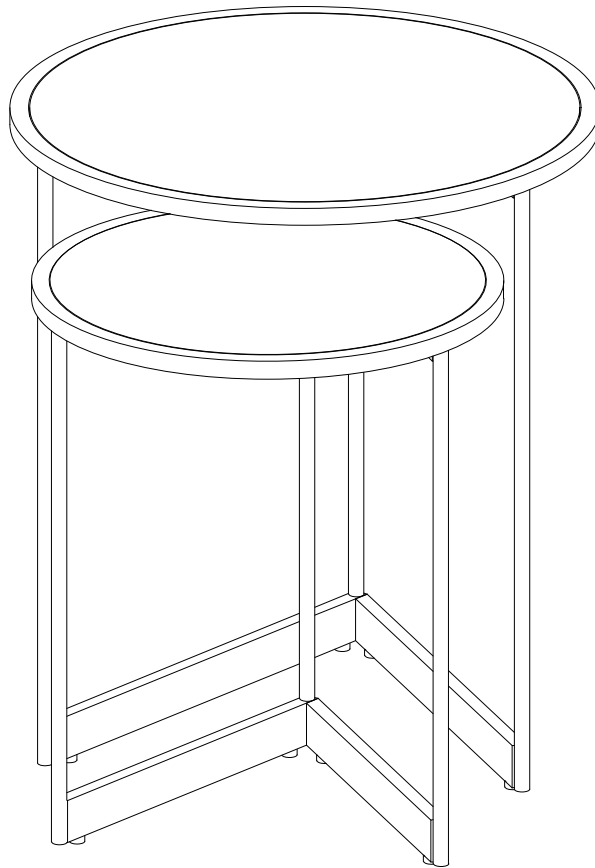

Werkzeug Phillips-schraubendreher
tool phillips head screwdriver



Montagedauer 30 Minuten
assembling time 30 minutes

Achtung!



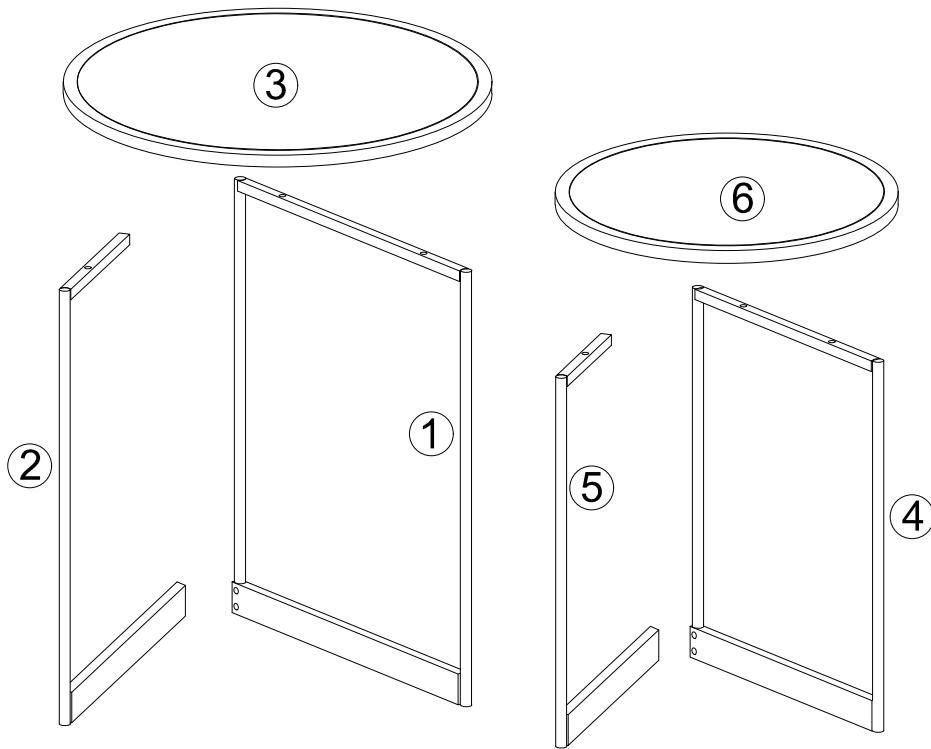

- 1 - Lesen Sie bitte sorgfältig unsere Montageanleitung, bevor Sie anfangen Ihr Produkt aufzubauen.
- 2 - Der Aufbau Ihres Produktes soll auf einer sauberen und glatten Oberfläche durchgeführt werden. Wir empfehlen Ihnen die Verpackungskartons zu nutzen, um den Boden, auf dem die Montage stattfinden wird, zu abdecken.
- 3 - Kontrollieren Sie bitte die Schrauben regelmäßig und bei Bedarf ziehen Sie erneut die Schrauben, die eventuell nicht mehr so fest sind.
- 4 - Vermeiden Sie bitte den Kontakt zwischen scharfer Gegenstände und Ihrer Möbeloberfläche.
- 5 - Bitte vermeiden Sie Stöße gegen Ihre Möbeloberfläche.

Attention!



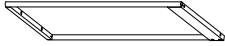

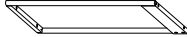
- 1 - Please read the assembly instructions very carefully before assembling your product.
- 2 - The product assembly has to be carried out on a clean and flat surface. We recommend the use of the packaging material (cartons/cardboards) to cover your room surface during assembly in order to protect the floor.
- 3 - The screws and bolts of your furniture have to be tightened periodically.
- 4 - Please avoid contact to sharp objects.
- 5 - Please avoid hitting the furniture surface.



Part List

			
①×1pc	②×1pc	③×1pc	④×1pc
			
⑤×1pc	⑥×1pc		

Hardware List

			
M6×18mm	M6×22mm		M4
Ⓐ×4pcs	Ⓑ×6pcs	Ⓒ×8pcs	Ⓓ×1pc

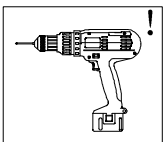

PLEASE BE CAREFUL DO NOT DAMAGE THE HOLE POSITION WHEN YOU USE POWER TOOLS !

Step 1

M6×18mm
A ×2PCS

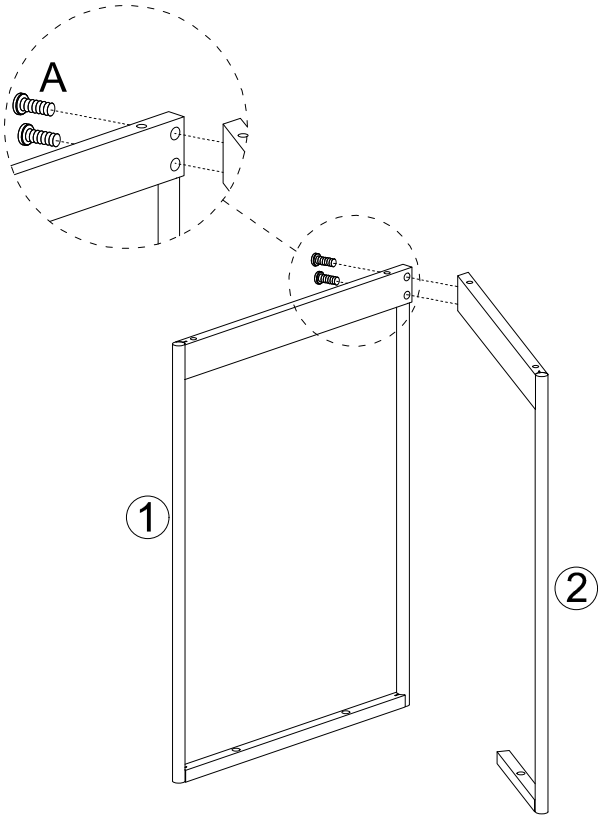

Step 2

M6×22mm
B ×3PCS

C ×4PCS

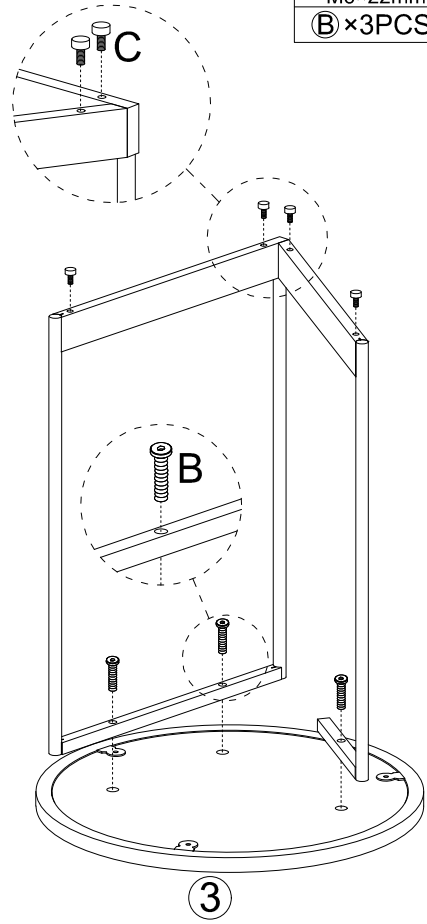

Step 3

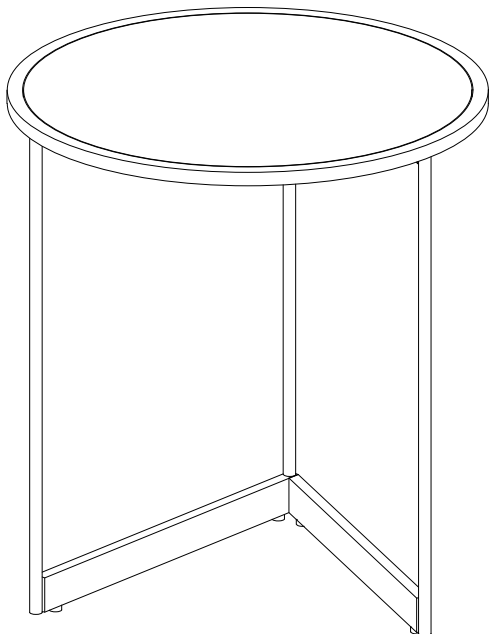

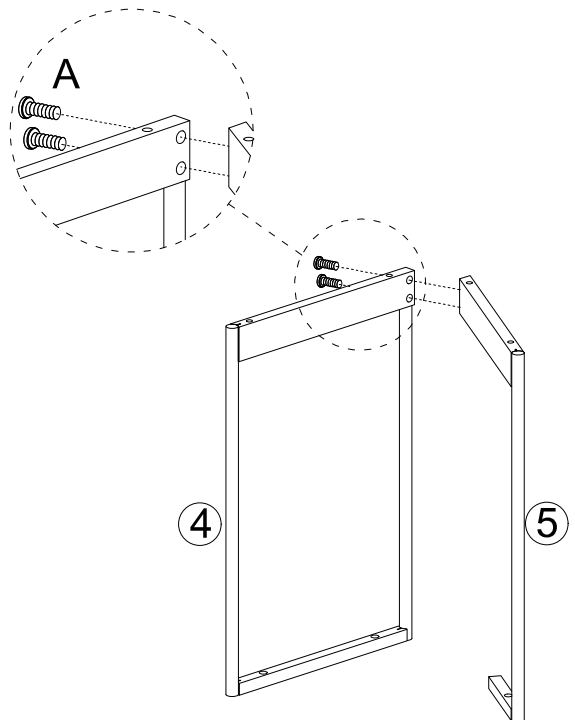

Step 4

M6×18mm
A ×2PCS

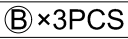

Step 5

 M6×22mm	 C ×4PCS
 B ×3PCS	

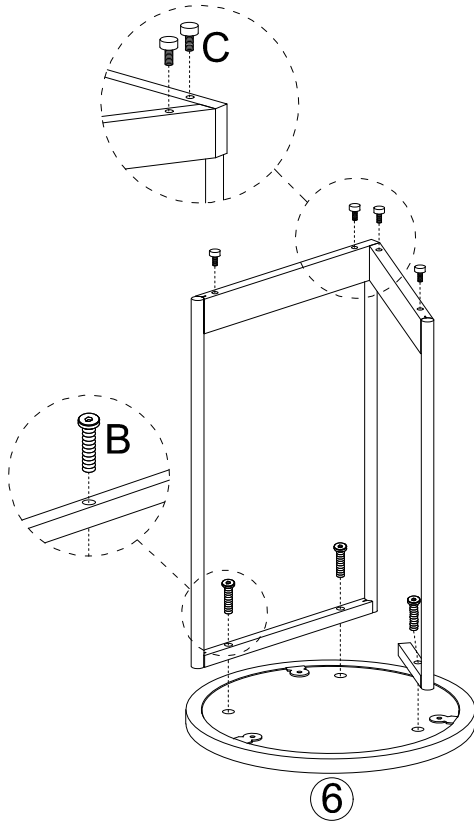

Step 6

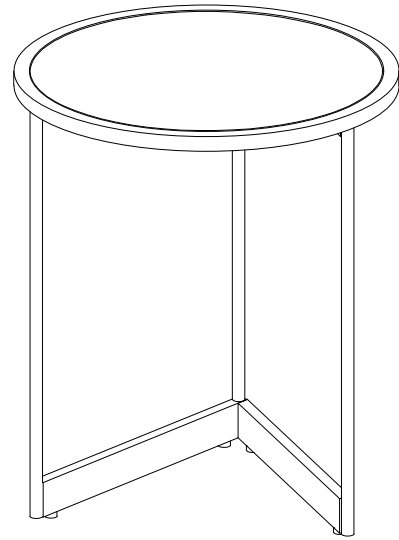

Step 7

