

# NOTICE

\*Please make sure that you have all parts indicated and they are in good condition before you begin assembly of this item. Refer to part list and hardware list below for guidance.

\*This item should be assembled on a soft surface to prevent scratching the finish during assembly.

\*This item may require periodic tightening.

\*If you are having difficulty, our friendly Customer Care team is always here to help. Please email

## PREPARATION

\*Before beginning assembly of product, make sure all parts are present. Compare parts with part contents list and hardware contents list.

\*If any part is missing or damaged, do not attempt to assemble the product.







\*Estimated Assembly Time: 30 minutes.

\*Tools Required for Assembly (included): Allen Key

## CARE AND MAINTENANCE

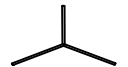
Always use felt pads under all articles to prevent discoloration or softening of the lacquer. Plastic and rubber bases on it can discolor wood. Wipe up spills immediately and avoid common hazards such as hot dishes, harsh solvents and abrasives. Cleaning should be done with a soft lint free cotton cloth dampened with water or furniture polish. On highly used surfaces we recommend applying a quality pastewax which should be used on a regular basis to provide additional protection from scratches and spills. How often you apply the wax depends on how much wear the furniture receives.

### Part List and Hardware List

PIECE	DESCRIPTION	PICTURE	QUANTITY
A	Panel		1X
B	leg		3X
C	Metal tube		1X
HW1	Socket Screws 6x0.5X45MM		6X
HW2	Flat washer 6mm		6X
HW3	Split Lock washer 6mm		6X
HW4	Allen key		1X

Product Dimensions: 35.43"D x 17.71"H

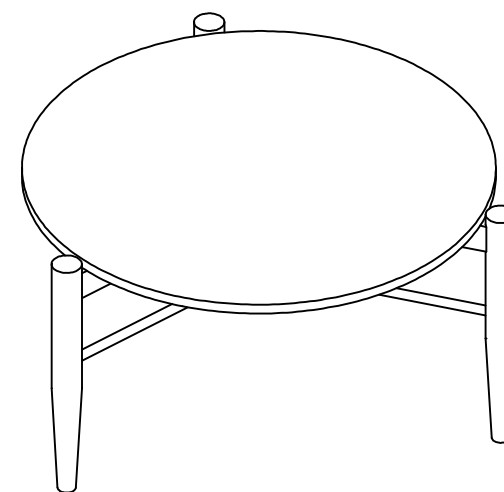

**⚠ WARNING ⚠**

Weight Capacity - 180 LBS

Warning : Do not stand on Table

Warning : Do not over torque bolts.

# PREPARATION

\*Before beginning assembly of product, make sure all parts are present. Compare parts with part contents list and hardware contents list.\*If any part is missing or damaged, do not attempt to assemble the product.

\*Estimated Assembly Time: 30 minutes.

\*Tools Required for Assembly (included): Allen Key

\*If you are having difficulty, our friendly Customer Care team is always here to help. Please email

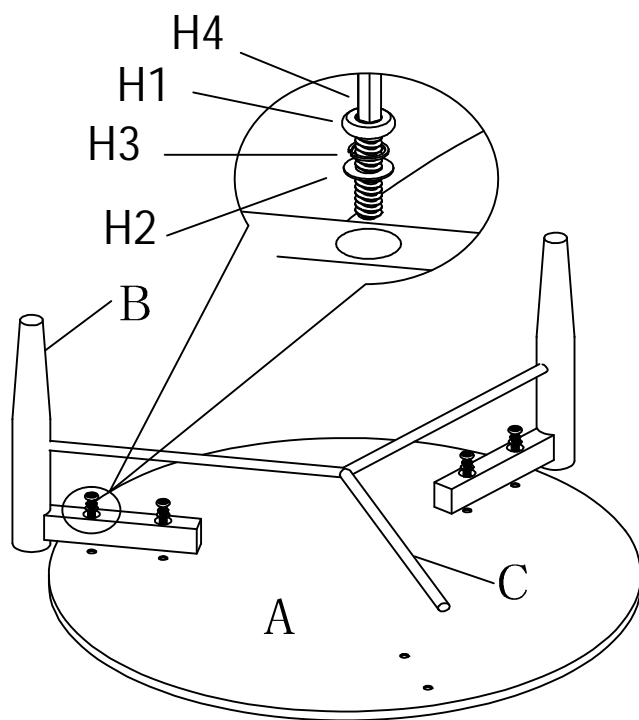

**STEP1:** Attach leg (B) to panel(A) using Allen bolt (H1)  
Spring washer (H3) and flat washer (H2), Tighten  
with allen key (H4). Attach metal tube(C) to leg(B).

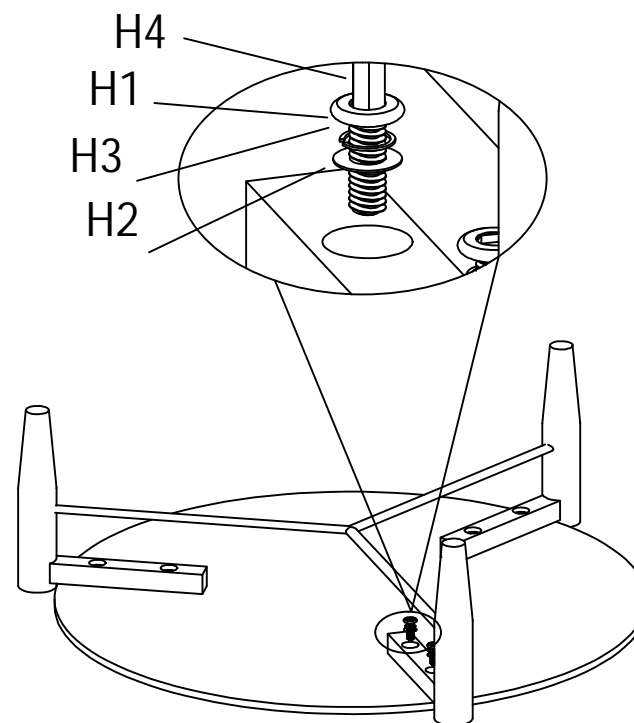

**STEP2:** Attach leg (B) to panel(A) using Allen bolt (H1)  
Spring washer (H3) and flat washer (H2), Tighten  
with allen key (H4). Stand table upright. Assembly is complete.