

HEAVY DUTY A-FRAME METAL SWING SET

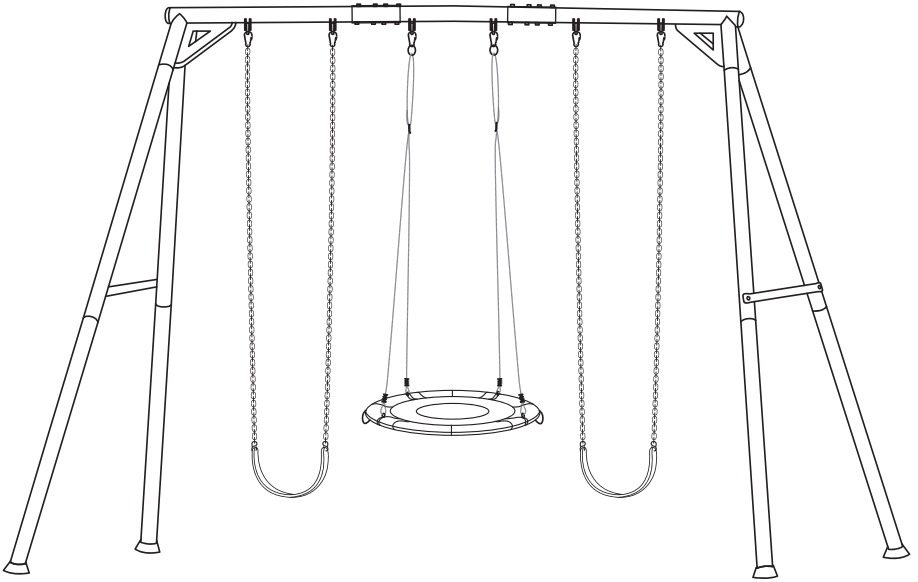

Please read the user manual carefully before use, and retain it for future reference.

CONTENTS

- 01** OPERATION INSTRUCTIONS AND WARNING
- 02** SAFE PLAY ZONE
- 03** PRODUCT STRUCTURE
- 04** PARTS LIST
- 06** ASSEMBLY INSTRUCTIONS
- 16** MAINTENANCE AND CARE



OPERATION INSTRUCTIONS AND WARNING

Before use, prepare a level surface with the proper Safe Play Zone. Follow the warning and operation instructions during use.

- Ensure there are no missing pieces before assembly and each use.
- Check the package and ensure no small parts have fallen out during shipment.
- The product is not intended for public use.
- Always keep safety in mind during assembly and use.
- Ensure proper and complete assembly, use and supervision. Always give adult supervision when used by children.
- The maximum weight is 600 lb. Instruct children to sit in the center of the swings with their full weight on the seats.
- Do Not allow children to use the swing set until properly assembled.
- Do Not move the swing set while it is in use.
- Do Not twist swing chains or ropes or loop them over the swing beam.
- Do Not allow children to swing empty seats.
- Do Not allow children to get off the swing seat while it is in motion.
- Do Not allow children to use the swing set while it is wet.
- Do Not attach items to the swing set that are not designed for use with the equipment, such as but not limited to, jump ropes, clotheslines, pet leashes and cables.
- Do Not add extra length to the chains or ropes. The chains or ropes provided are designed for the swinging element(s).
- Check and make sure all of the fasteners are secured before each use.
- Place the swing set no less than 6.6ft (2m) from any structure or obstruction such as a fence, garage, house, overhanging branches, laundry or electrical wires.

The following chart explains the fall height in feet from which a life-threatening head injury would not be expected.

Critical Heights in Feet (m) of Tested Materials

Material	Uncompressed Depth			Compressed Depth
	6" (152mm)	9" (228mm)	12" (304mm)	To 9" (228mm)
Wood Chips	7' (2.13m)	10'-12' (3.0m-3.6m)	11' (3.35m)	10' (3.05m)
Double-Shredded Bark Mulch	6' (1.83m)	10'-12' (3.0m-3.6m)	11' (3.35m)	7' (2.13m)
Engineered Wood Fibers	6' (1.83m)	7' (2.13m)	> 12' (3.66m)	6' (1.83m)
Fine Sand	5' (1.52m)	5' (1.52m)	9' (2.74m)	5' (1.52m)
Coarse Sand	5' (1.52m)	5' (1.52m)	6' (1.83m)	4' (1.22m)
Fine Gravel	5' (1.52m)	7' (2.13m)	10' (3.05m)	6' (1.83m)
Medium Gravel	5' (1.52m)	5' (1.52m)	6' (1.83m)	5' (1.52m)
Shredded Tires	10'-12' (3.0m-3.6m)	N/A	N/A	N/A

SAFE PLAY ZONE

NOTE:

- Place the swing set on a level, well-drained ground, not less than 6.6 ft (2 m) from any structure or obstruction such as a fence, garage, house, overhanging branches, laundry or electrical wires.
- Provide enough room for safe use.
- Separate active and quiet activities from each other. For example, locate sandboxes away from the swing.
- Do not install the swing set over concrete, asphalt, packed earth or other hard surfaces.
- Create a site free of obstacles that could cause injuries. Such as low overhanging tree branches, overhead wires, tree stumps and/or roots, large rocks, bricks and concrete.

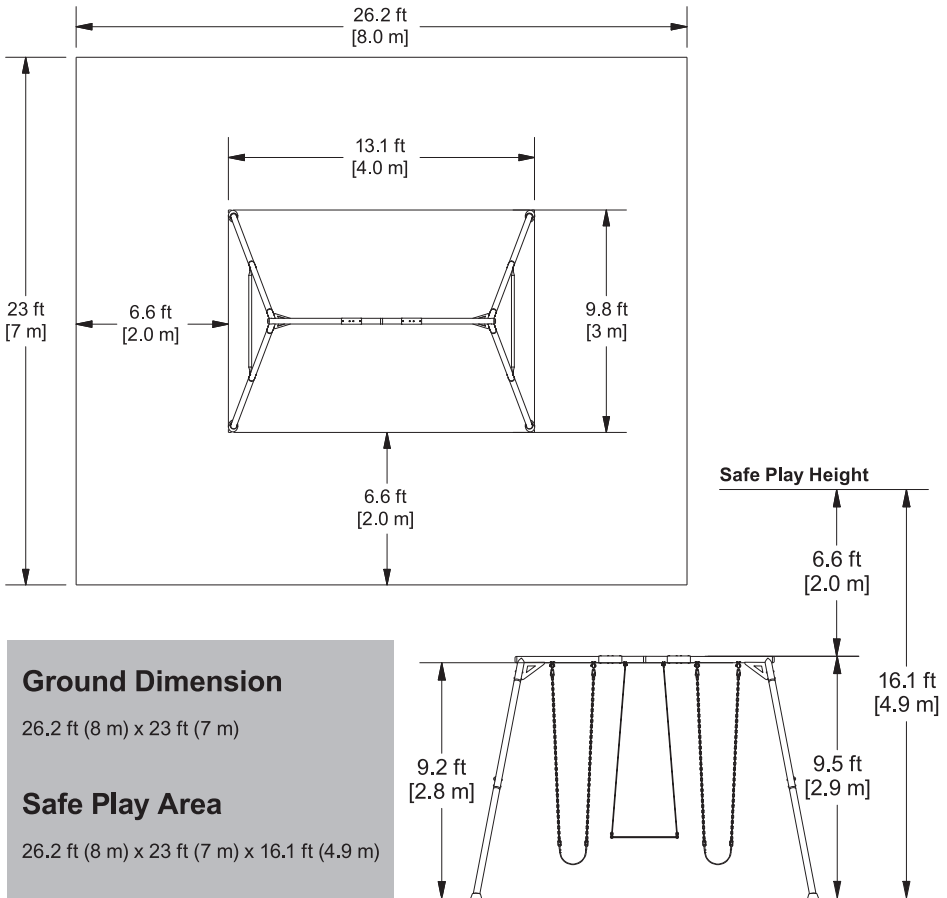

PRODUCT STRUCTURE

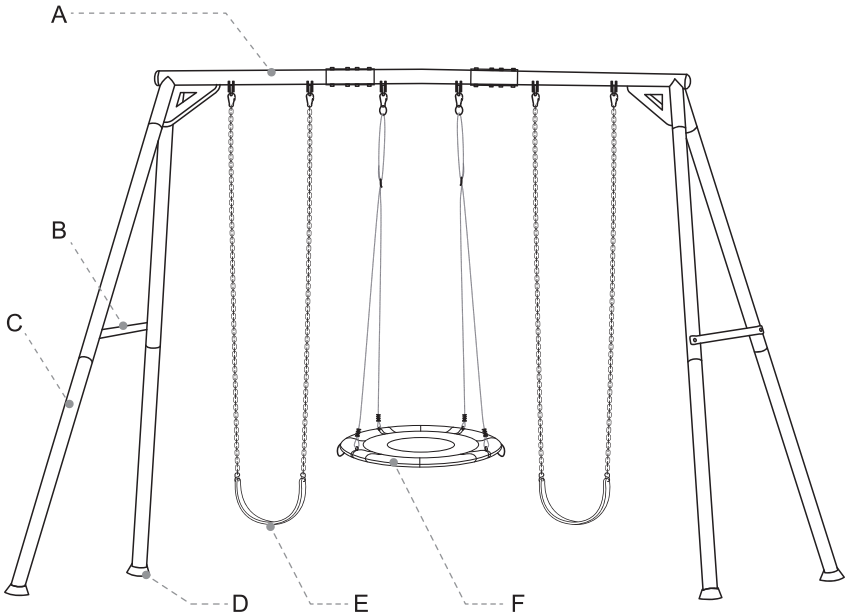

A. Swing beam

B. Cross bar for frame leg

C. Frame leg

D. Anchored feet

E. Belt swing

F. Saucer swing

SPECIFICATIONS

Product Name

Heavy Duty A-Frame Metal Swing Set

Main Material

Metal











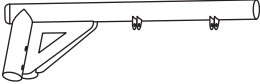

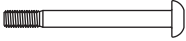

Weight Limit

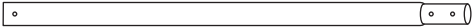



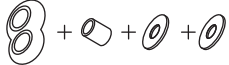





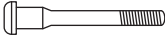



600 lb

Recommended Age of Use

3+ years

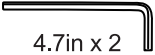
PARTS LIST

NO.	Part Name	Picture	QTY
1	End Swing Beam		2
2	Middle Swing Beam		1
3	End Plug for Beam		2
3-1	Bolt for Beam		8
3-2	Nut Cap		8
3-3	Washer		8
4	Upper Frame Leg		4
5	Lower Frame Leg		4
6	Cross Bar for Frame Leg		2
7	Casing Tube		2
8	Swing Anchored Feet		4
9	Hanger Set		6
10	Ground Stake		4
11	Iron Bar		1
12	Bolt for Ground Stake		4(set)

13	3" Bolt		4
14	2.8" Bolt		12
15	Nut		16
16	1.5" Bolt for Hanger		6
17	Nut for Hanger		6
18	Belt Swing with Chain		2(set)
19	Saucer Swing Seat		1
20	Iron Tube with Foam		4
21	Swing Rope with Eye Bolt		2(set)
22	Carabiner		6(set)
23	Allen Wrench	 4.7in x 2  3.3in x 1	3
24	T-spanner		1
25	Spanner		1

Tools You May Need (not included)

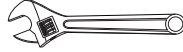





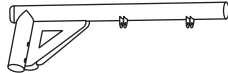
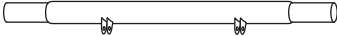

ASSEMBLY INSTRUCTIONS

Step 1: Swing Beam Assembly

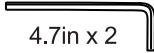
NOTE: The assembly is required at least two adults.

Tools and Parts Required:

NO.	Part Name	Picture	QTY
1	End Swing Beam		2
2	Middle Swing Beam		1
3	End Plug for Beam		2
7	Casing Tube		2
23	Allen Wrench		2
3-1	Bolt for Beam		8
3-2	Nut Cap		8
3-3	Washer		8



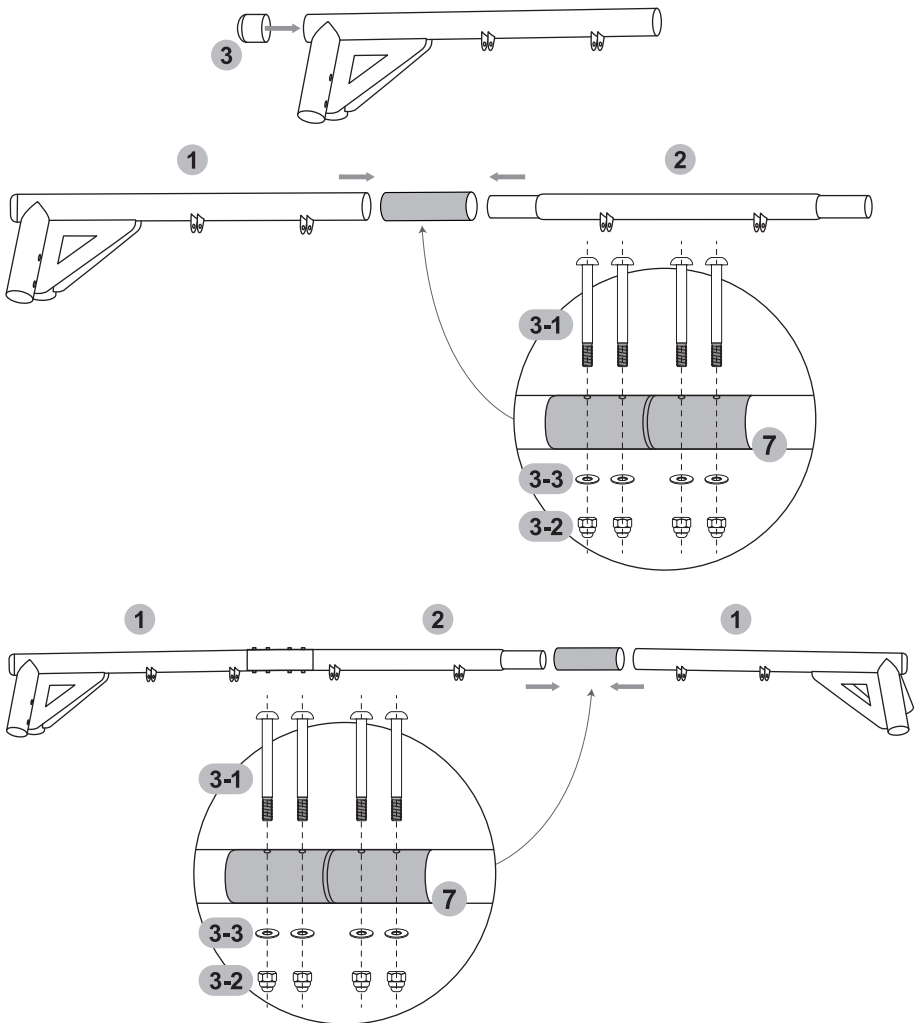

1. Plug the two **3** end plugs into the two **1** end beam frames.
2. Flip the **2** middle beam and one **1** end beam over with the hanger connections facing up as shown. Keep the **2** and **1** on a level, connect them with the **7** casing tube and align holes, and secure them with 4pcs bolts and 4pcs nuts.
3. Repeat to secure the other **1** end beam to the **2** middle beam as shown in the following figure.

! Do Not fully tighten bolts at this time.

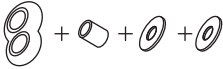
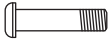

Step 2: Swing Hanger to Swing Beam

Tools and Parts Required:

NO.	Part Name	Picture	QTY
9	Hanger Set		6
16	1.5" Bolt for Hanger		6
17	Nut for Hanger		6
23	Allen Wrench	 3.3in x 1	1
25	Spanner		1

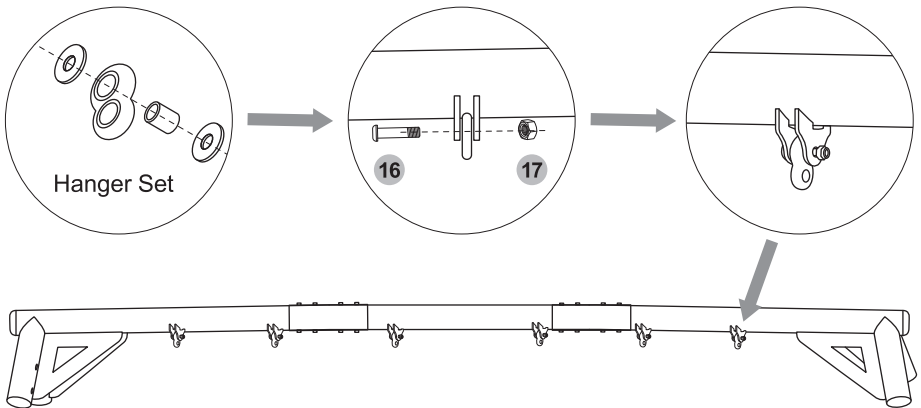

Install the **9** hanger set to the swing beam, and secure with the **16** 1.5" bolt and the **17** nut as shown in the following figure.

 Do Not fully tighten bolts at this time.

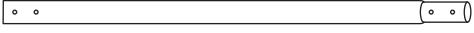

Step 3: Leg Assembly

Tools and Parts Required:

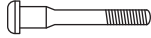
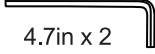
NO.	Part Name	Picture	QTY
4	Upper Frame Leg		4
5	Lower Frame Leg		4
14	2.8" Bolt		4
15	Nut		4
23	Allen Wrench		2

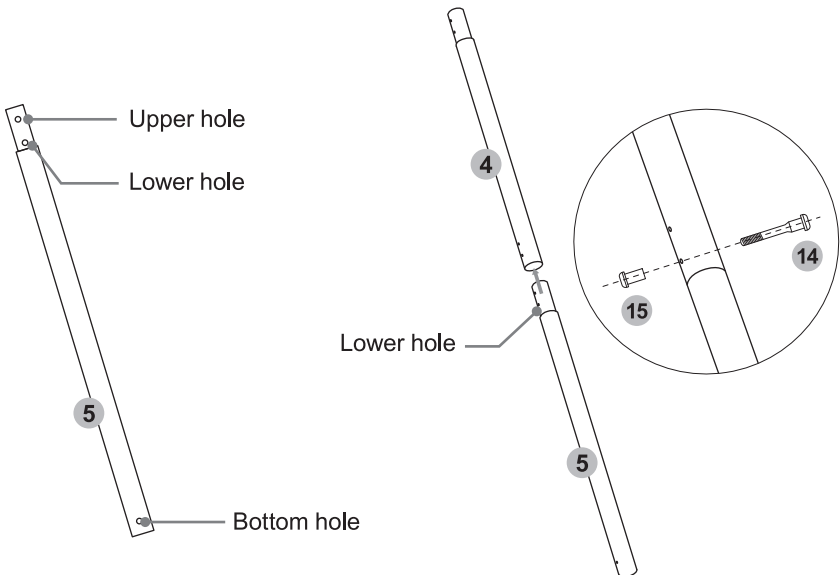

1. Connect one 4 upper frame leg to one 5 lower frame leg, and secure them with the 14 2.8" bolt and 15 nut through the lower hole as shown in the following figure.
2. Repeat to connect the other three 4 upper legs and 5 lower legs.

 Do Not fully tighten bolts at this time.

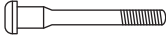
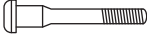

Step 4: Leg to Swing Beam & Cross Bar Assembly

Tools and Parts Required:

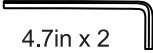
NO.	Part Name	Picture	QTY
6	Cross Bar for Frame Leg		2
13	3" Bolt		4
14	2.8" Bolt		8
15	Nut		12
23	Allen Wrench		2



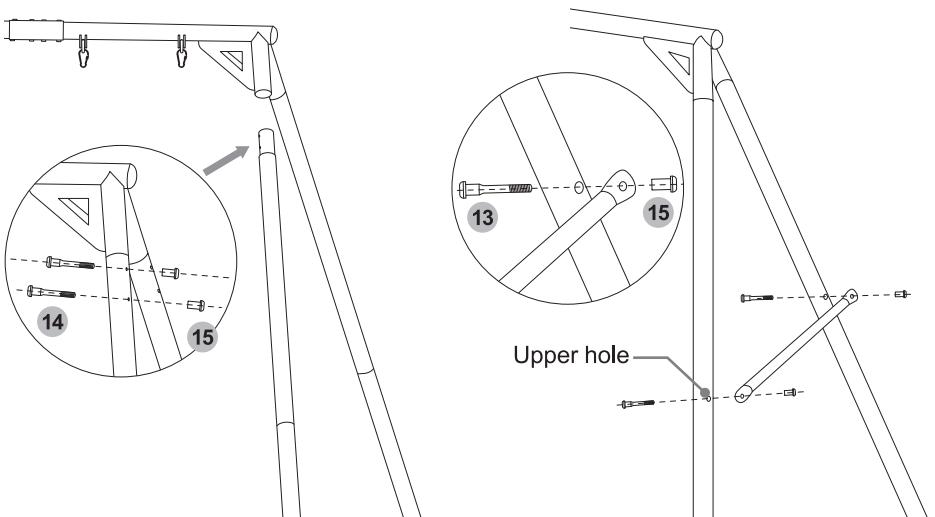

1. Connect the assembled frame leg to the swing beam, and secure them with the **14** 2.8" bolt and **15** nut as shown in the following figure.
2. Use the **6** cross bar to secure two adjacent legs with the **13** 3" bolt and **15** nut through the upper hole of the **5** lower frame leg.

 Do Not fully tighten bolts at this time.



Step 5: Final Check and Tighten

Tools and Parts Required:

NO.	Part Name	Picture	QTY
8	Swing Anchored Feet		4
10	Ground Stake		4
11	Iron Bar		1
12	Bolt for Ground Stake		4(set)
24	T-spanner		1

1. Use the **11** iron bar to insert the **10** ground stake into the ground at an angle of 30~45° to the ground.
2. Install the **8** anchored feet to the swing frame leg with the **10** ground stake and **12** bolt set.
3. Tighten all fasteners at this time.

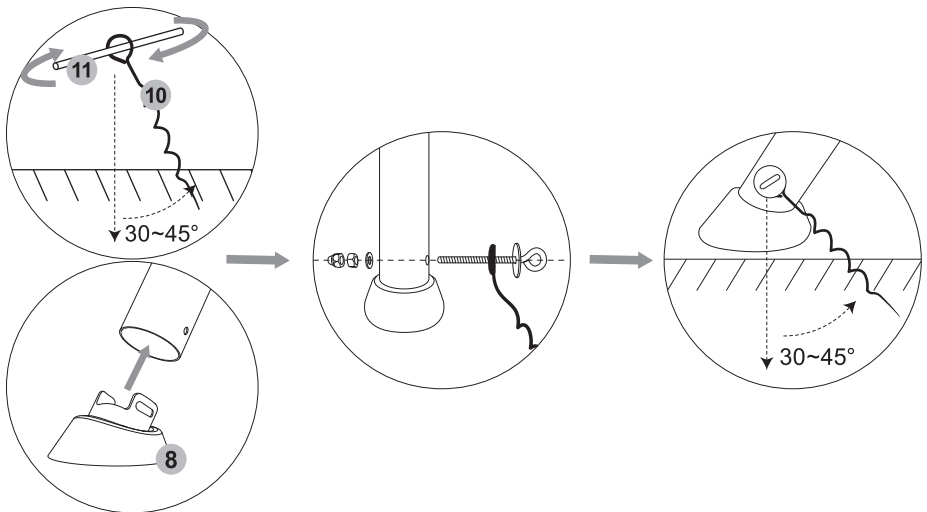

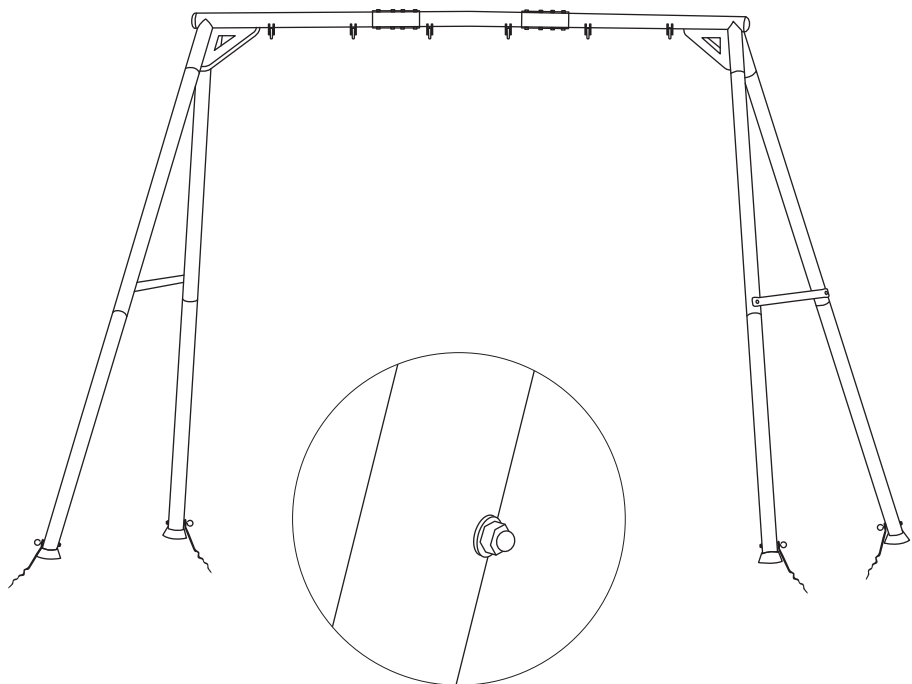



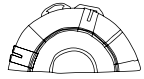

Tighten all fasteners

Sept 6: Swing Assembly

Tools and Parts Required:

NO.	Part Name	Picture	QTY
18	Belt Swing with Chain		2(set)
19	Saucer Swing Seat		1
20	Iron Tube with Foam		4
21	Swing Rope with Eye Bolt		2(set)
22	Carabiner		6(set)
24	T-spanner		1

Belt swing assembly: connect the chains of the belt swing to the 22 carabiner.

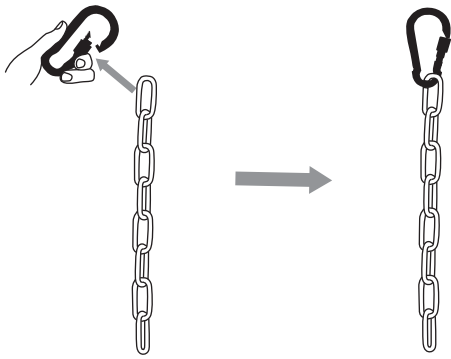

Saucer swing assembly:

1. Insert 4 **20** iron tubes into the **19** swing seat.
2. Connect the adjacent iron tubes two by two to form a circle.
3. Cover it up with the hook & loop, then insert the bolt on the **21** swing rope into the hole at the joint.
4. Put the washer and nut onto the bolt, and tighten with the **24** spanner until 3-4 threads of bolts are exposed, then put the nut cap onto the bolt and tighten it.
5. Unlock the **22** carabiner, and connect it to the swing rope.

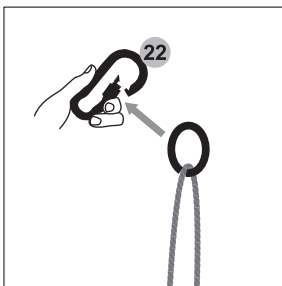
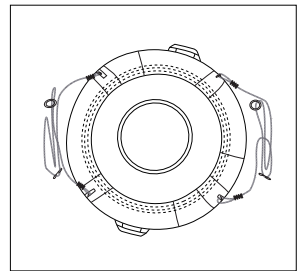
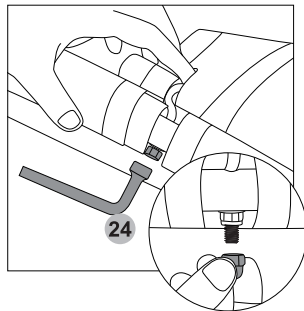
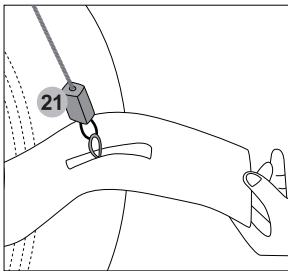
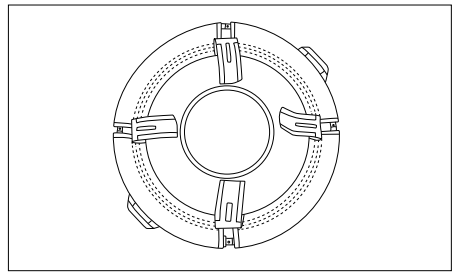
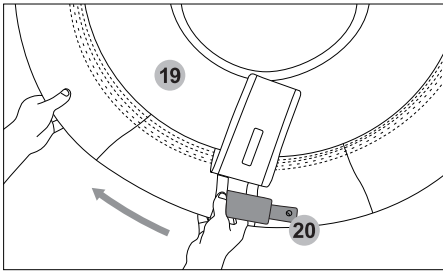

Step 7: Hanging Swings to Swing Beam

Attach the swings assembled in step 6 to the swing hangers as shown in the following figure.

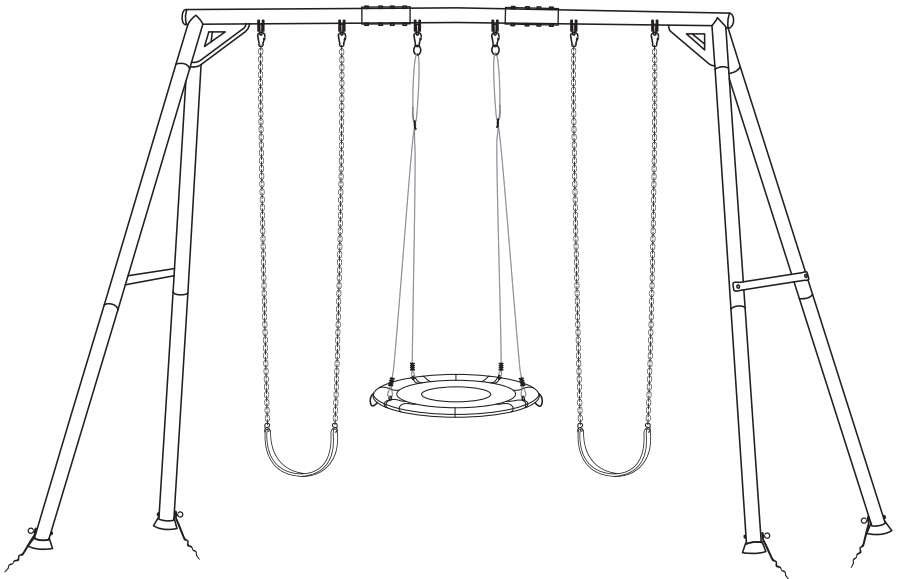
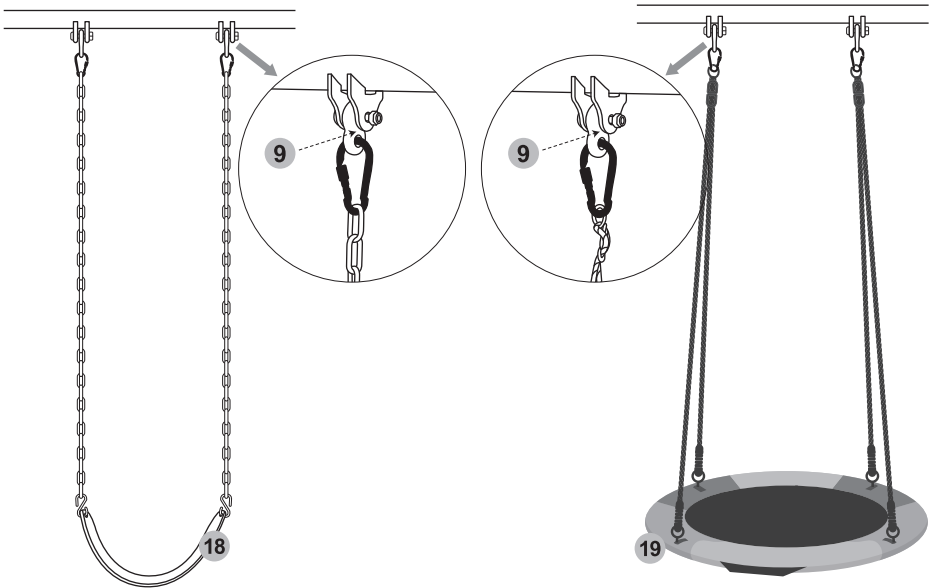

MAINTENANCE AND CARE

Routine checks and maintenance are required for the safe use of the swing set.

Saucer swing assembly:

- Tighten all fasteners.
- Lubricate all metallic moving parts if necessary.
- Check all protective coverings on bolts, tubes, bars and corners. Replace them if they are loose, cracked or missing.
- Check all moving parts for wear, rust or other deterioration, including swing seats, ropes, and chains. Replace if necessary.
- Check metal parts for rust. If found, sand and repaint with a non-lead paint that complies with the 16 CFR 1303.
- Reinstall any plastic parts that have been removed for the cold season, such as swing seats or any other items.
- Rake and inspect the depth of protective surfacing materials to avoid compaction and to maintain appropriate depth. Replace if necessary. (See page 1)

Twice a month during play season:

- Tighten all fasteners.
- Check all protective coverings on bolts, tubes, bars, and corners. Replace them if they are loose, cracked or missing.
- Rake and check the depth of protective surfacing materials to avoid compaction and to maintain appropriate depth. Replace if necessary. (See page 1)
- Once a month during play season:
 - Lubricate all metallic moving parts if necessary.
 - Check all moving parts for wear, rust or other deterioration, including swing seats, ropes and chains. Replace if necessary.

At the end of each play season or when the temperature drops below 40F (5C):

- Remove plastic swing seats and other items, and take them indoors or do not use them.
- Rake and check the depth of protective surfacing materials to avoid compaction and to maintain appropriate depth. Replace if necessary. (See page 1)
- If the warning sticker is illegible, destroyed, or removed, contact customer service for help.

Disposal of the swing set: make sure that no unreasonable hazards will exist at the time the swing set is discarded, and follow all local disposal requirements.