

# User's Manual

---

## Sofa

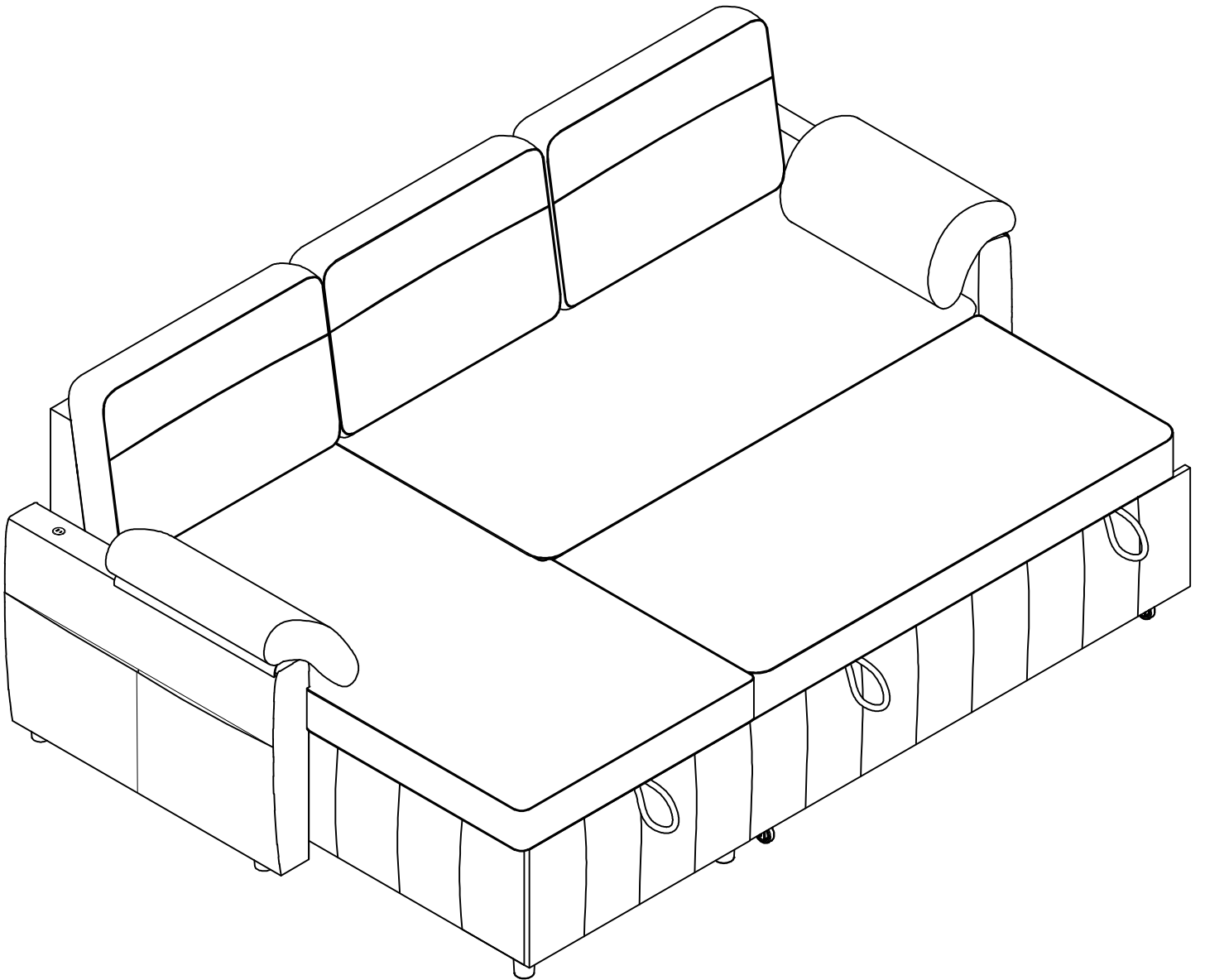

## **EN | ES**

If you have any questions, please contact us. Replacement for missing or damaged parts will be shipped ASAP!

## **EN | ES**

Si tiene alguna pregunta, por favor contáctenos. ¡El reemplazo de piezas faltantes o dañadas se enviará lo antes posible!

## Attention:

1. Please install other parts first, and then open the compressed backrest and seat cushion.
2. Be careful not to scratch the product when opening the compressed package.
3. The sponge is expected to recover in 48 hours, and you can speed up the recovery by patting the backrest.

### Assembly Option ①

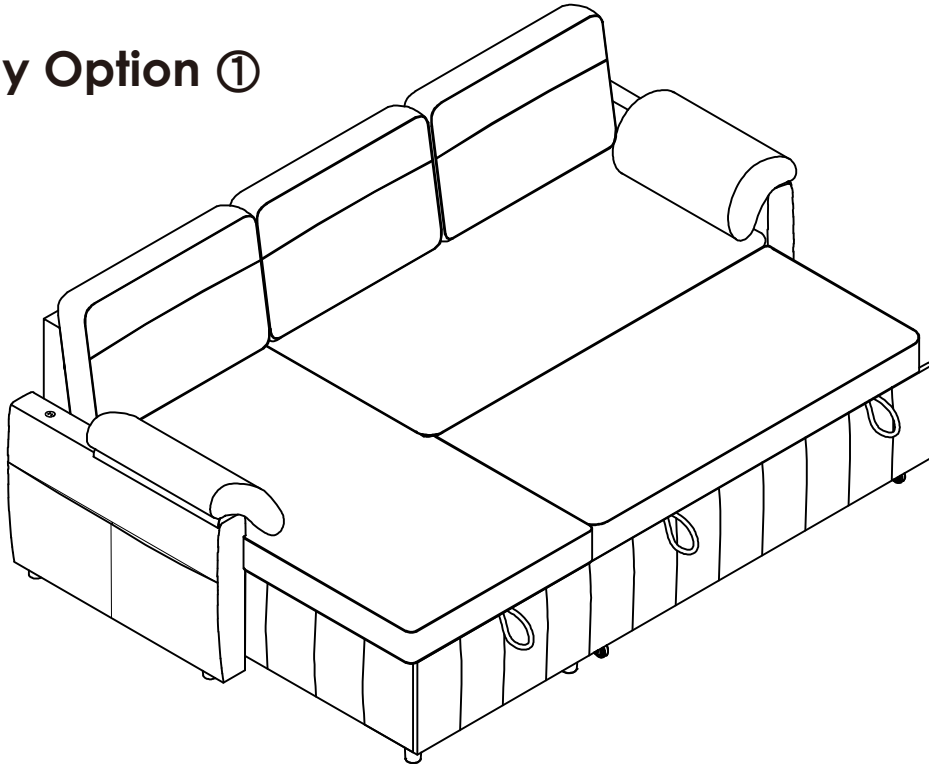

### Assembly Option ②

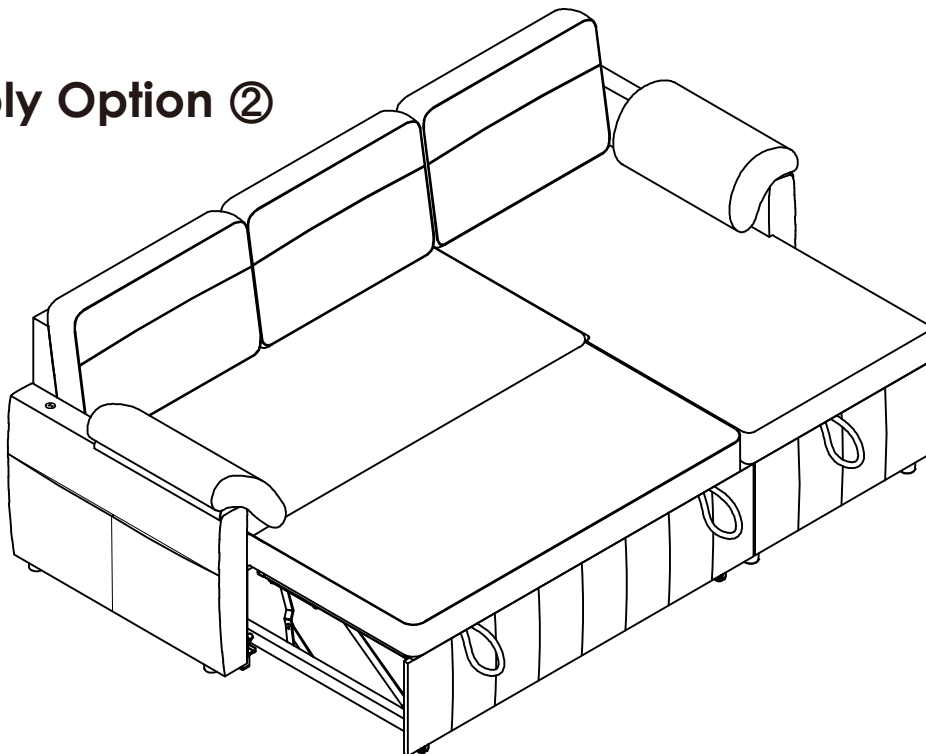

# Main Structure Accessories

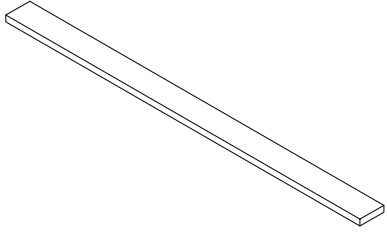
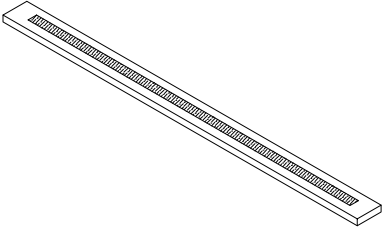
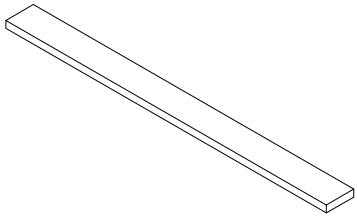
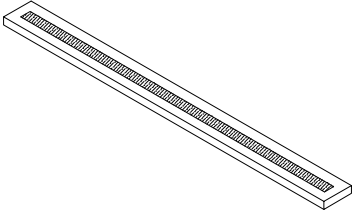
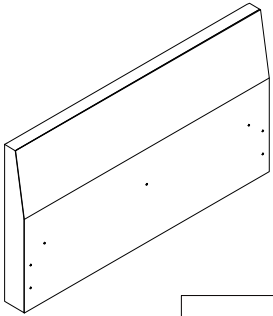
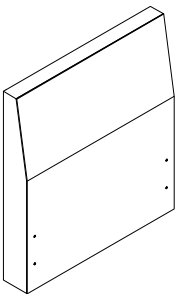
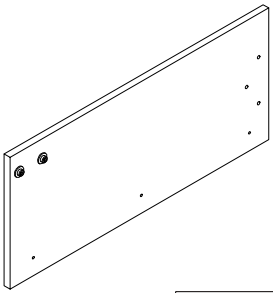
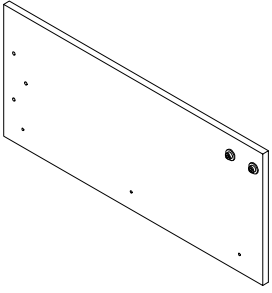
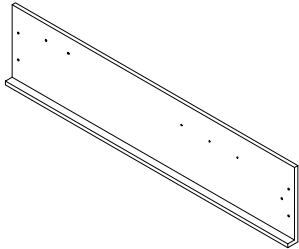
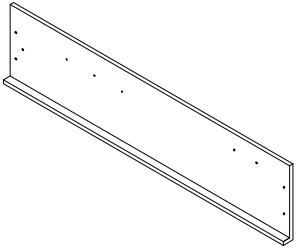
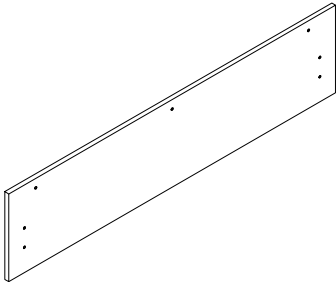
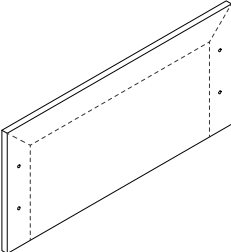
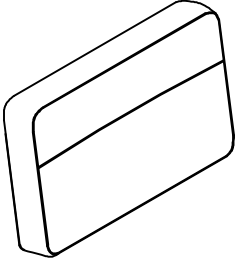
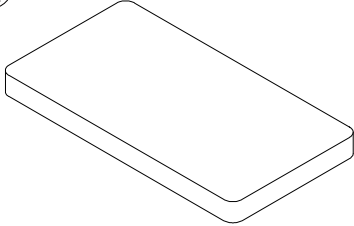
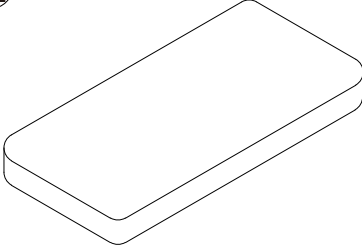
<p><b>A</b></p>  <p>18PCS</p>	<p><b>A1</b></p>  <p>4PCS</p>	<p><b>B</b></p>  <p>9PCS</p>
<p><b>B1</b></p>  <p>2PCS</p>	<p><b>C</b></p>  <p>1PC</p>	<p><b>C1</b></p>  <p>1PC</p>
<p><b>D</b></p>  <p>1PC</p>	<p><b>D1</b></p>  <p>1PC</p>	<p><b>D2</b></p>  <p>1PC</p>
<p><b>D3</b></p>  <p>1PC</p>	<p><b>E</b></p>  <p>1PC</p>	<p><b>E1</b></p>  <p>1PC</p>
<p><b>F</b></p>  <p>3PCS</p>	<p><b>F1</b></p>  <p>1PC</p>	<p><b>F2</b></p>  <p>1PC</p>

# Main Structure Accessories

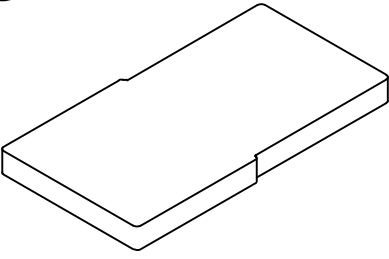
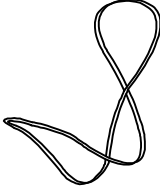
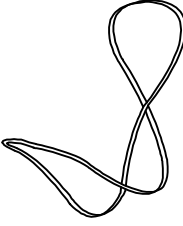
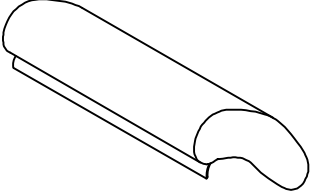
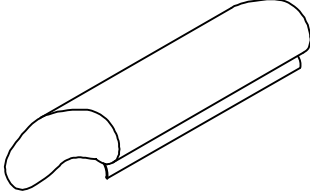
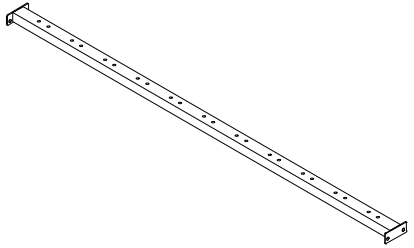
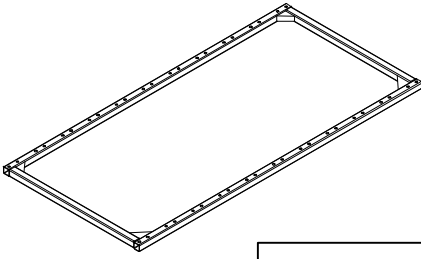
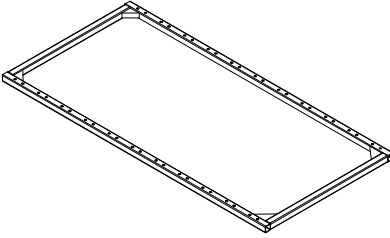
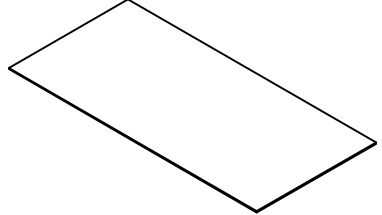
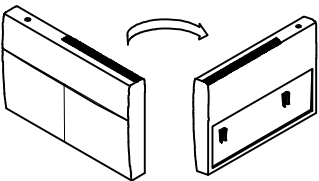
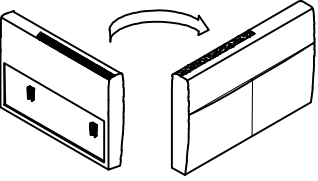
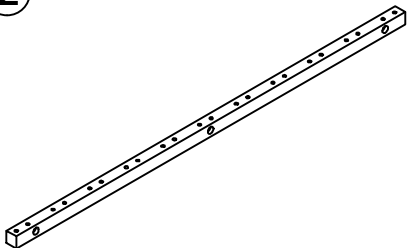
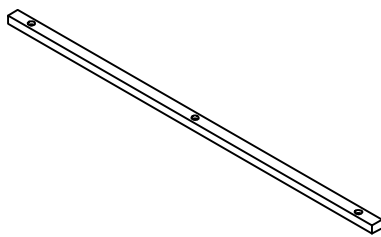
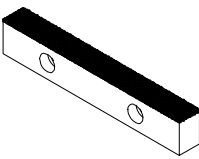
<p><b>F3</b></p>  <p>1PC</p>	<p><b>F4</b></p>  <p>short</p> <p>1PC</p>	<p><b>F4 -1</b></p>  <p>long</p> <p>2PCS</p>
<p><b>F5-R1</b></p>  <p>1PC</p>	<p><b>F5-R2</b></p>  <p>1PC</p>	<p><b>G</b></p>  <p>1PC</p>
<p><b>H</b></p>  <p>1PC</p>	<p><b>H1</b></p>  <p>1PC</p>	<p><b>Q</b></p>  <p>1PC</p>
<p><b>R1</b></p>  <p>1PC</p>	<p><b>R2</b></p>  <p>1PC</p>	<p><b>Z</b></p>  <p>1PC</p>
<p><b>Z1</b></p>  <p>1PC</p>	<p><b>Z2</b></p>  <p>2PCS</p>	

## Structural Accessories

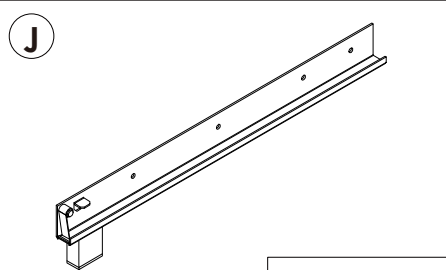
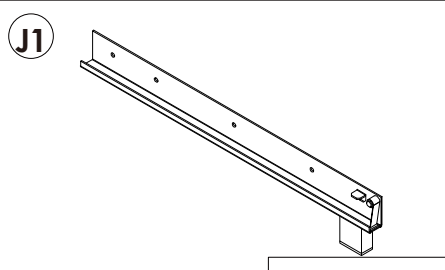
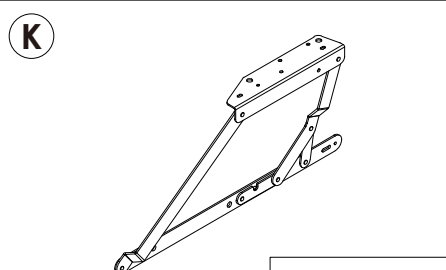
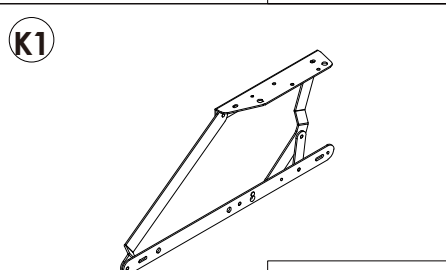
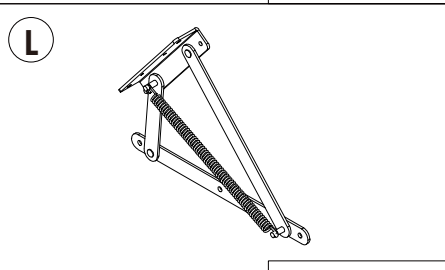
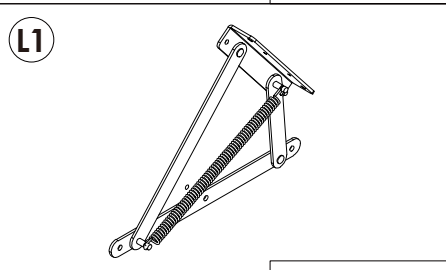
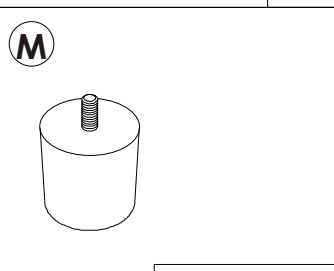
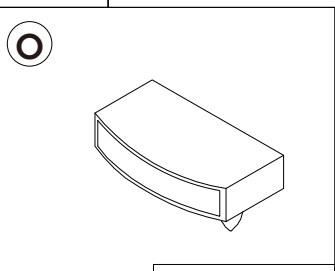
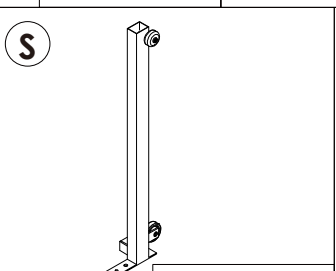
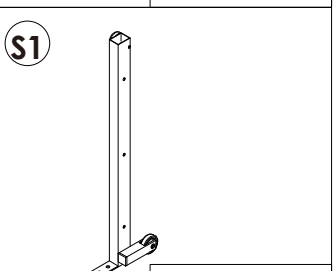
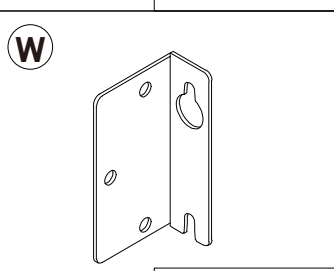
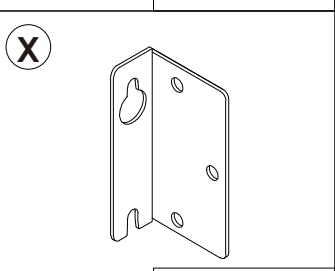
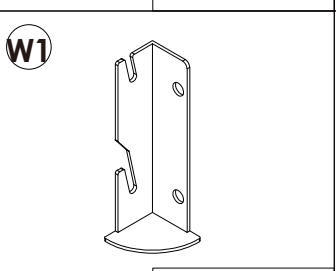
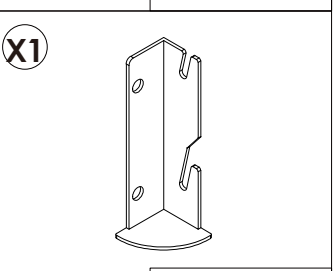
<p><b>J</b></p>  <p>1PC</p>	<p><b>J1</b></p>  <p>1PC</p>	<p><b>K</b></p>  <p>1PC</p>	
<p><b>K1</b></p>  <p>1PC</p>	<p><b>L</b></p>  <p>1PC</p>	<p><b>L1</b></p>  <p>1PC</p>	
<p><b>M</b></p>  <p>10PCS</p>	<p><b>O</b></p>  <p>66+3PCS</p>	<p><b>S</b></p>  <p>1PC</p>	<p><b>S1</b></p>  <p>1PC</p>
<p><b>W</b></p>  <p>2PCS</p>	<p><b>X</b></p>  <p>2PCS</p>	<p><b>W1</b></p>  <p>1PC</p>	<p><b>X1</b></p>  <p>1PC</p>

## Hardware Parts

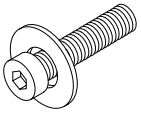
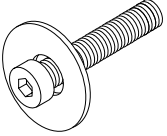
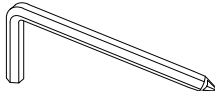
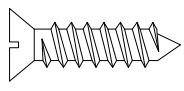
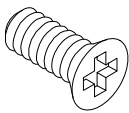
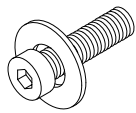
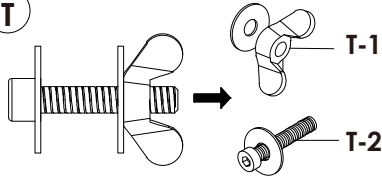
<p><b>N</b> Small gasket</p>  <p>M8×30mm 10+2PCS</p>	<p><b>N1</b> Large gasket</p>  <p>M8×45mm 2PCS</p>	<p><b>P</b></p>  <p>1PC</p>	<p><b>U</b></p>  <p>M5×14mm 8+1PCS</p>
<p><b>V</b></p>  <p>M6×17mm 20+1PCS</p>	<p><b>Y</b></p>  <p>M8×18mm 6PCS</p>	<p><b>T</b></p>  <p>M8×50mm 1SET</p>	

# Main Structure Accessories

CHAISE

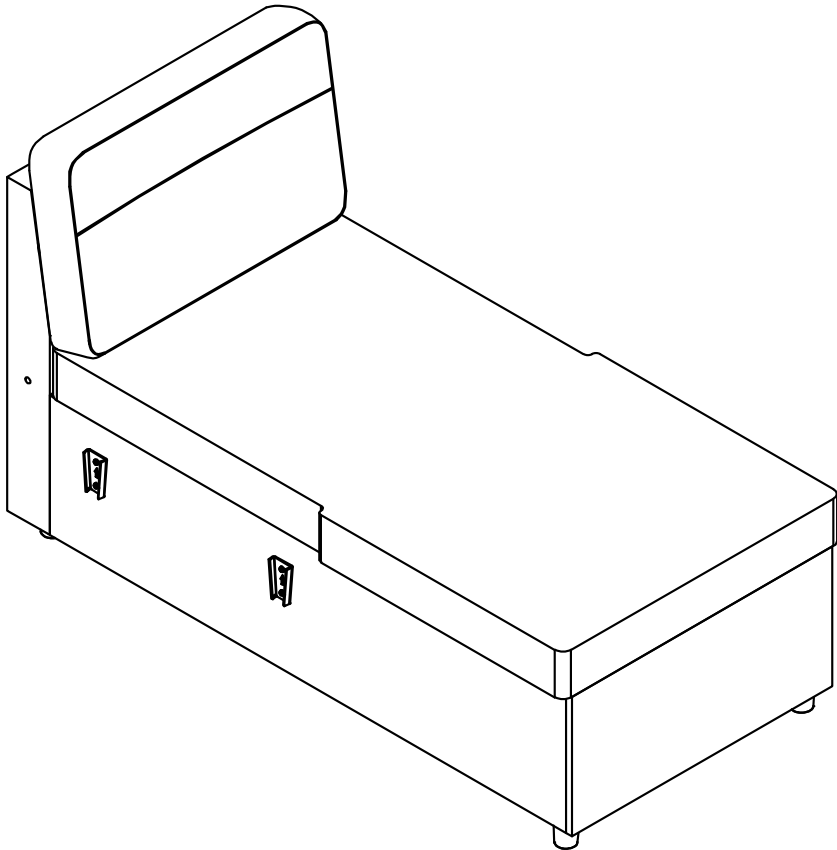
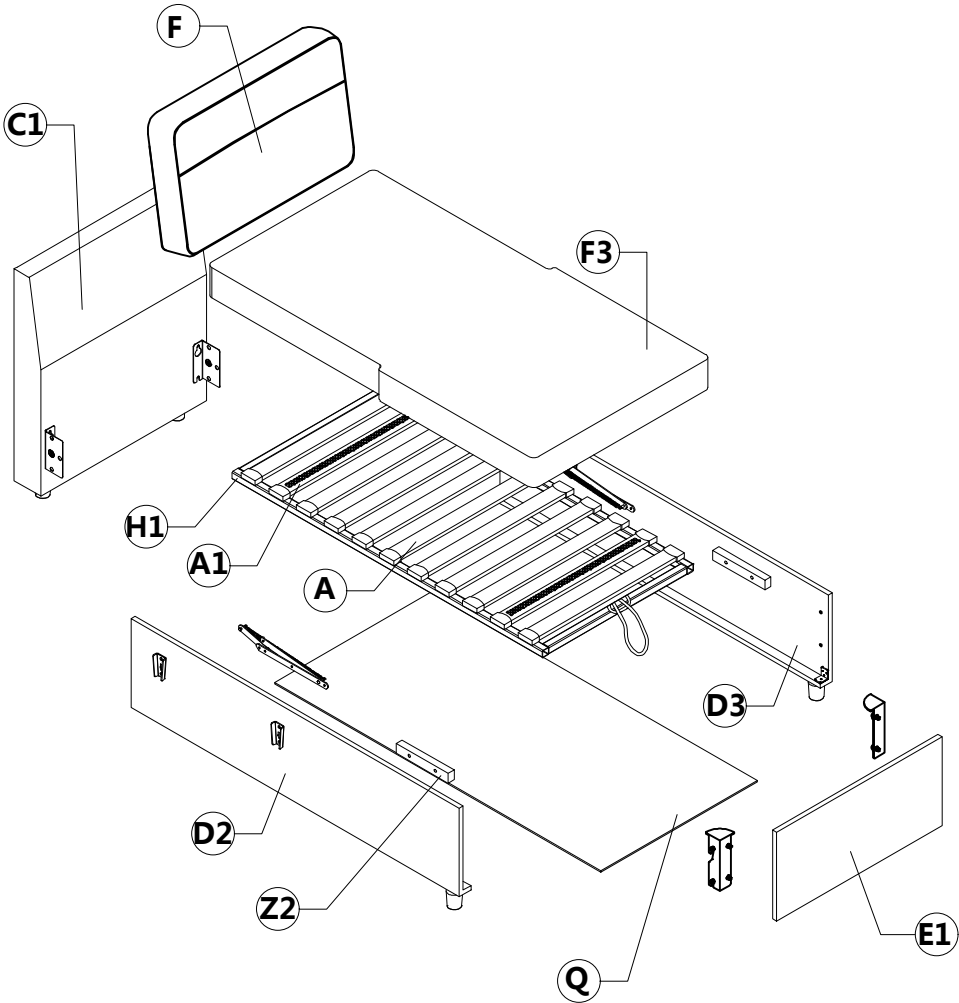



# Assembly Steps(EN)

## STEP 1

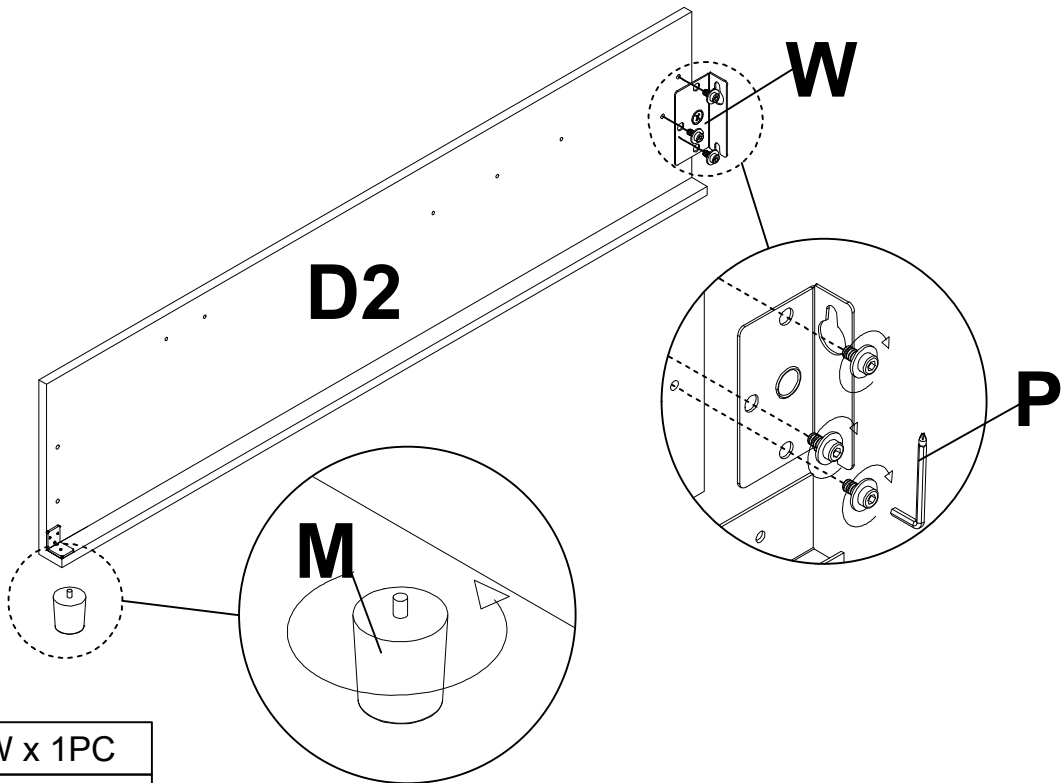
Loosen the screws first, and then lock the hanging piece (W)  
Pay attention to the opening up on the side near the foot post





	W x 1PC
	P x 1PC

## STEP 2

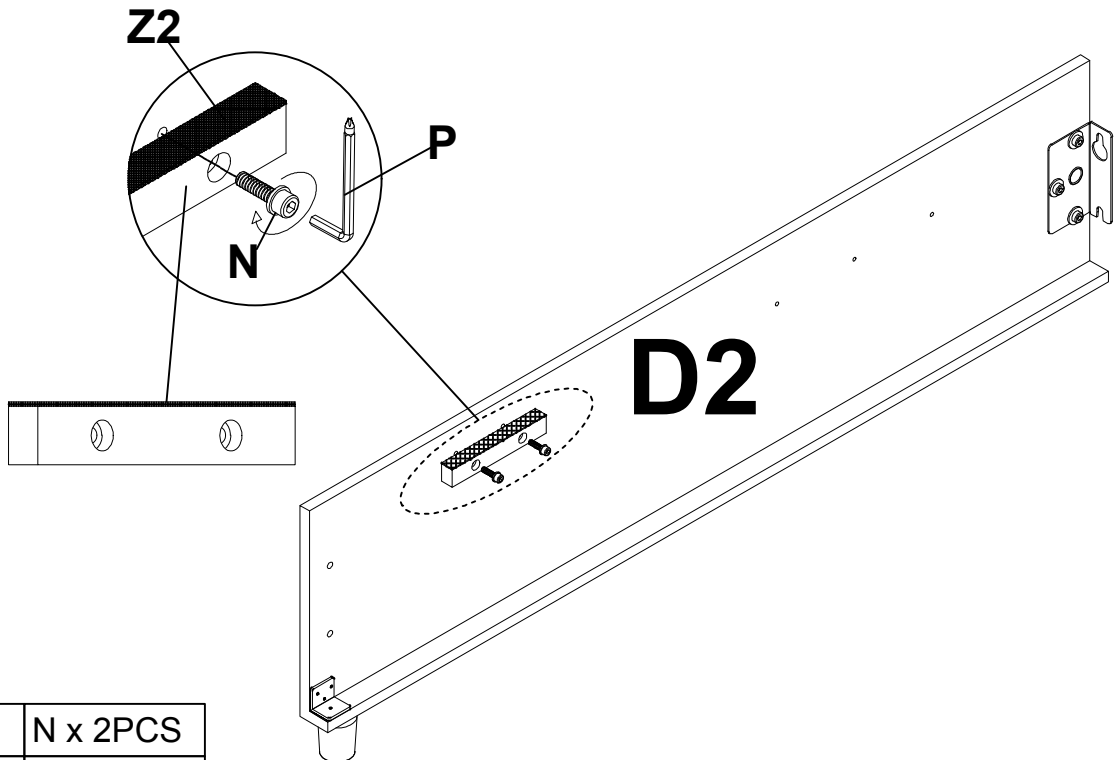
Note that the countersink hole faces outward  
and the EVA non-slip sticker faces upward when installing





	N x 2PCS
	P x 1PC

## Assembly Steps(EN)

### STEP 3

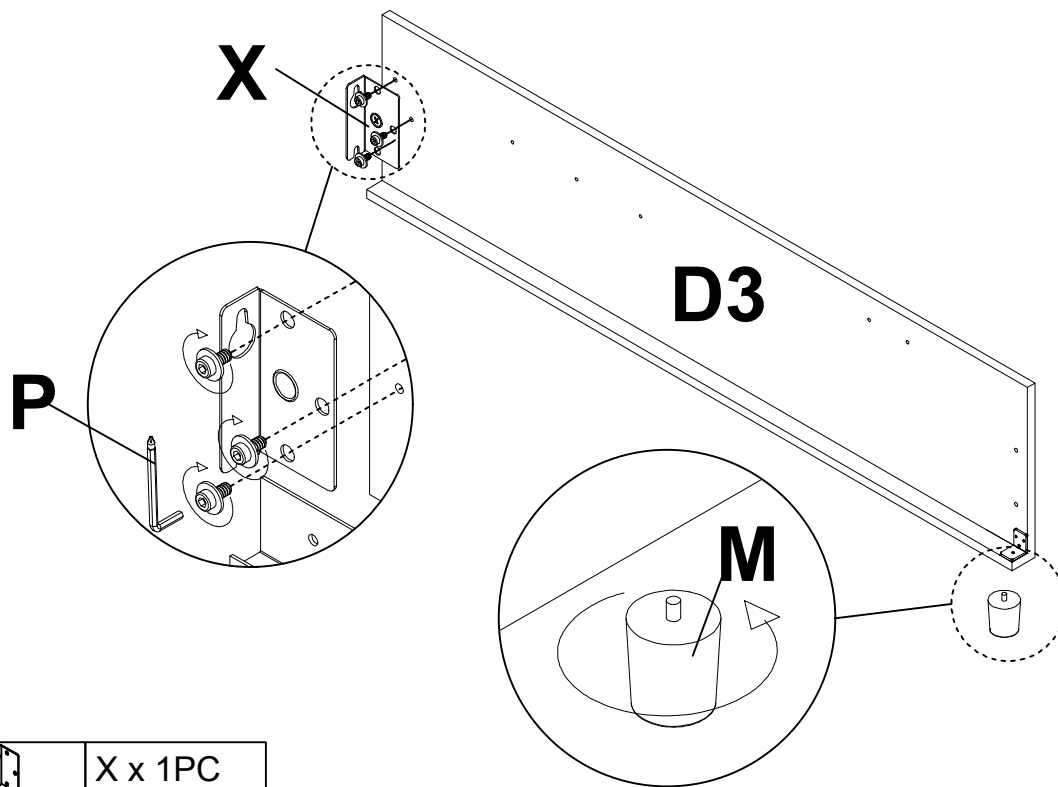
Loosen the screws first, and then lock the hanging piece  
Pay attention to the opening up on the side near the foot post





	X x 1PC
	P x 1PC

### STEP 4

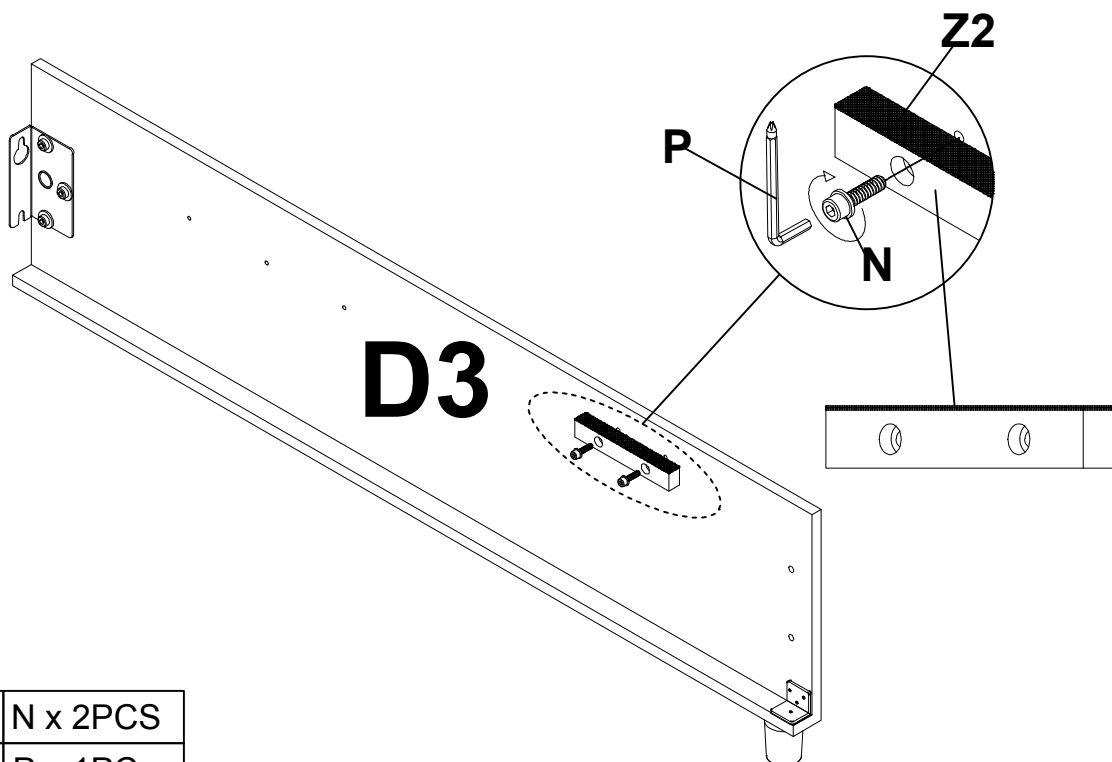
Note that the countersink hole faces outward  
and the EVA non-slip sticker faces upward when installing



	N x 2PCS
	P x 1PC

## Assembly Steps(EN)

### STEP 5

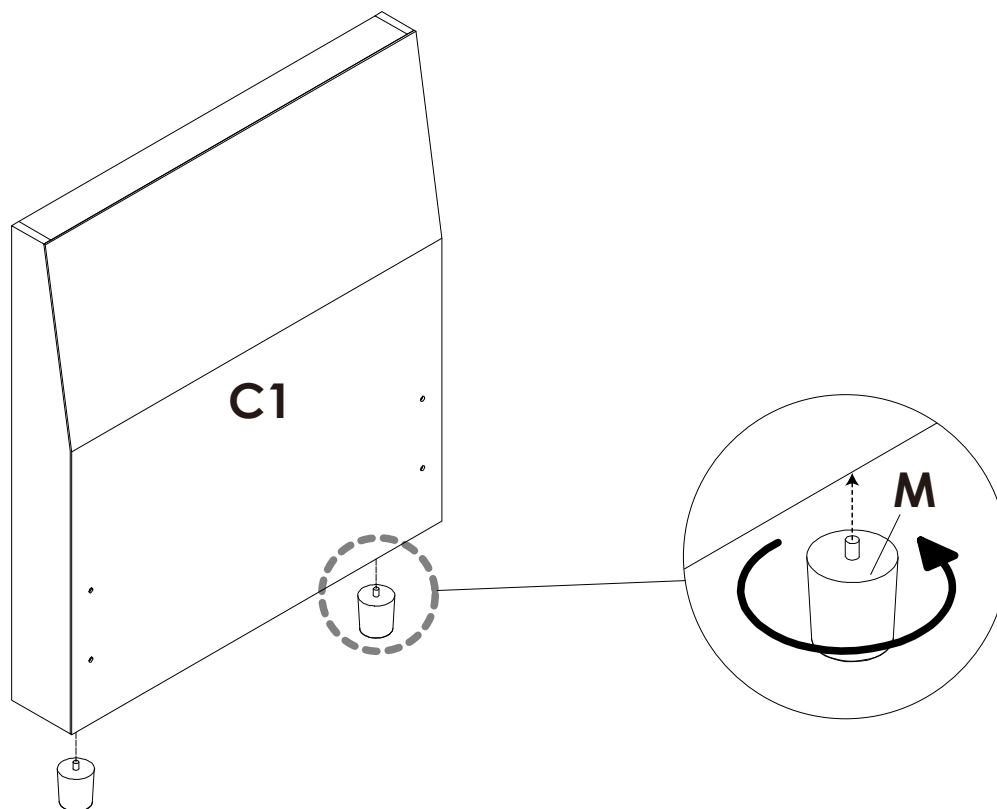

### STEP 6

First loosen the screws, install the mounting plate, and then lock the screws.

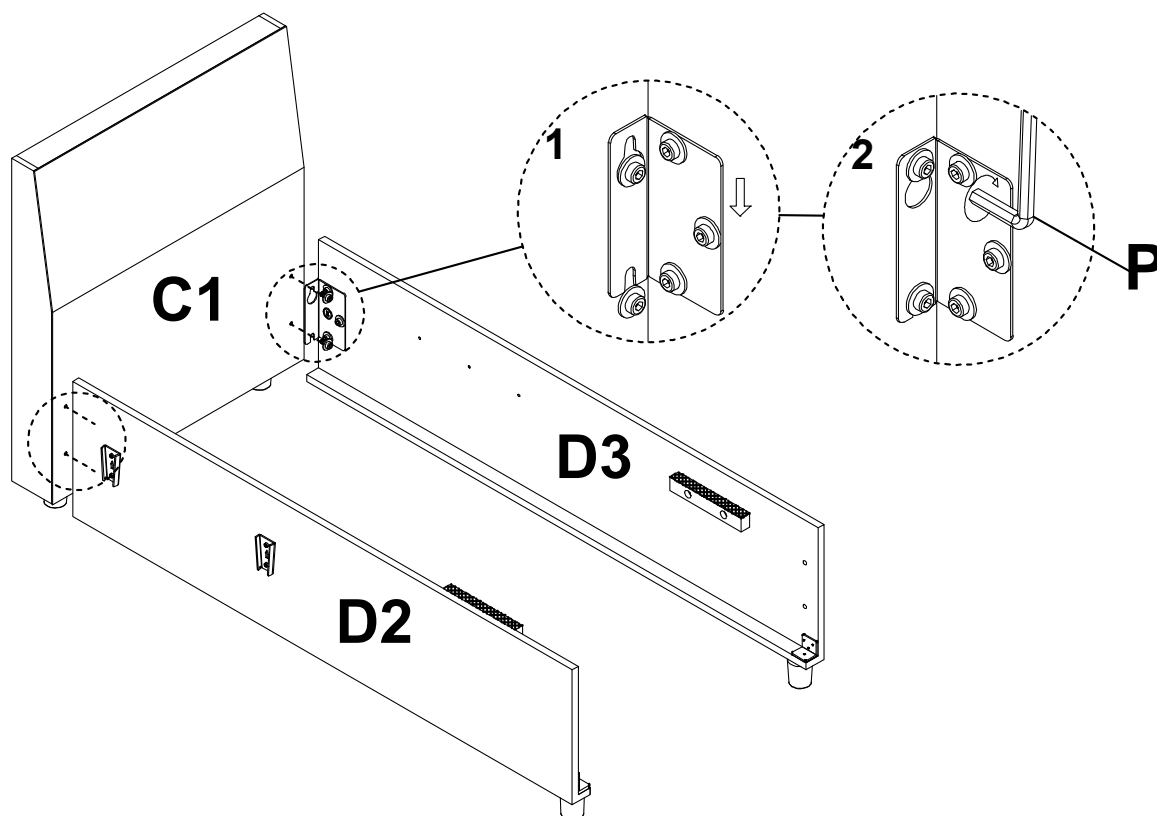

**P** x 1PC

# Assembly Steps(EN)

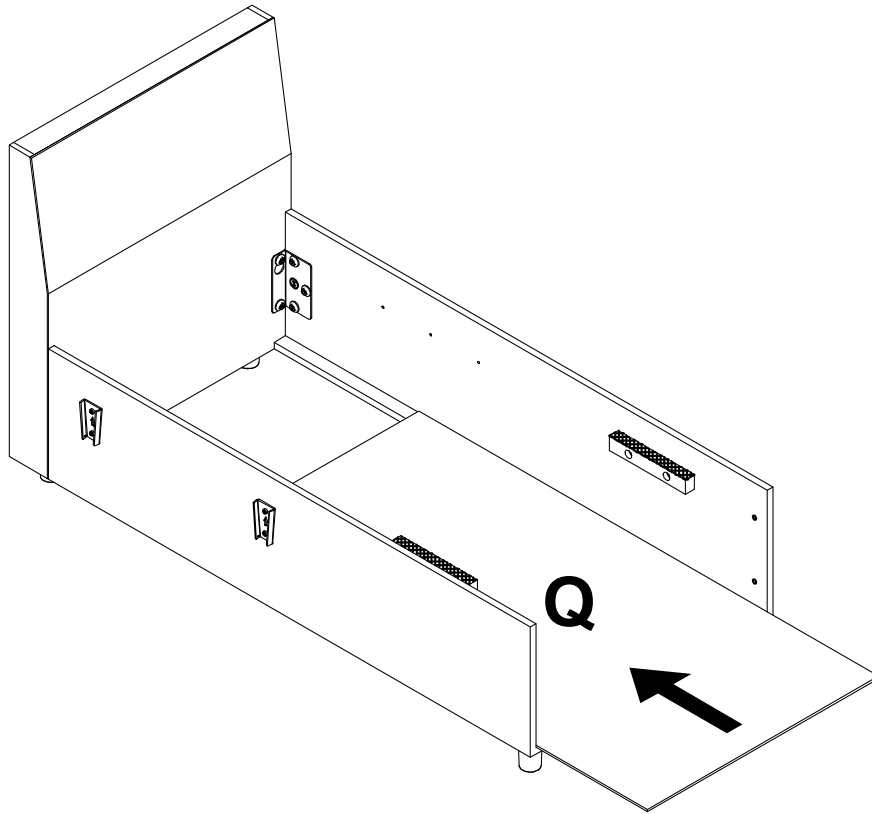

## STEP 7

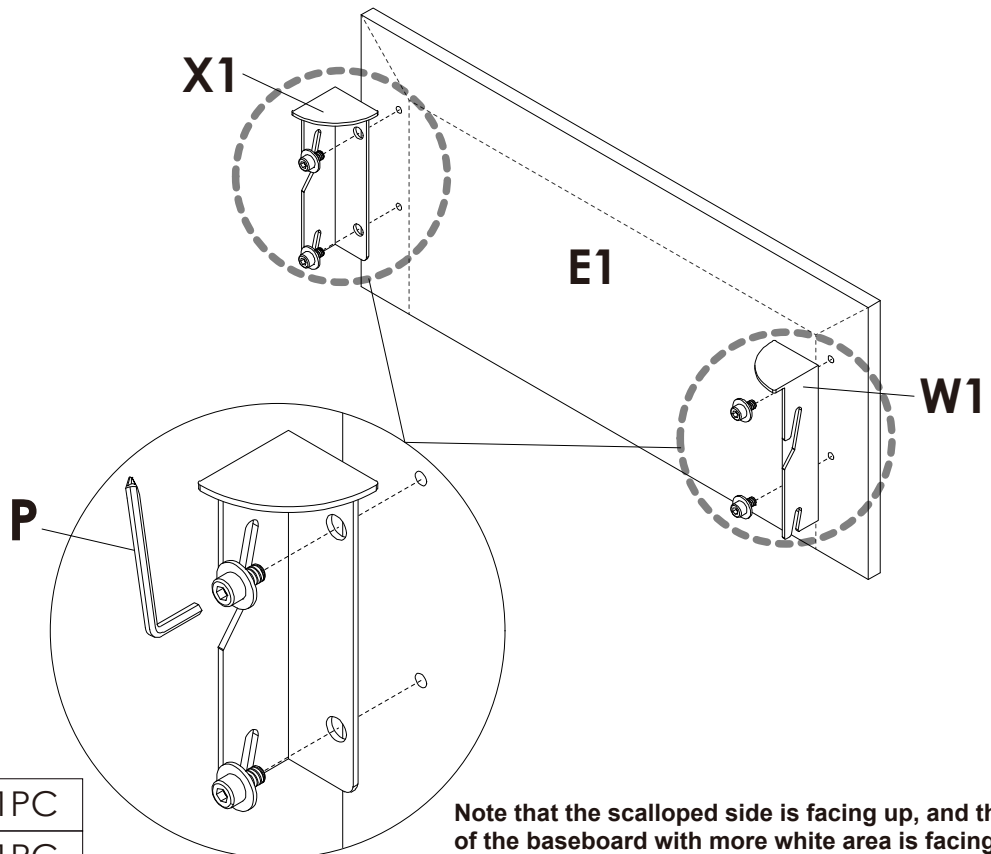

## STEP 8



Note that the scalloped side is facing up, and the side of the baseboard with more white area is facing up.

	<b>W1</b> x 1PC
	<b>X1</b> x 1PC
	<b>P</b> x 1PC

# Assembly Steps(EN)

## STEP 9

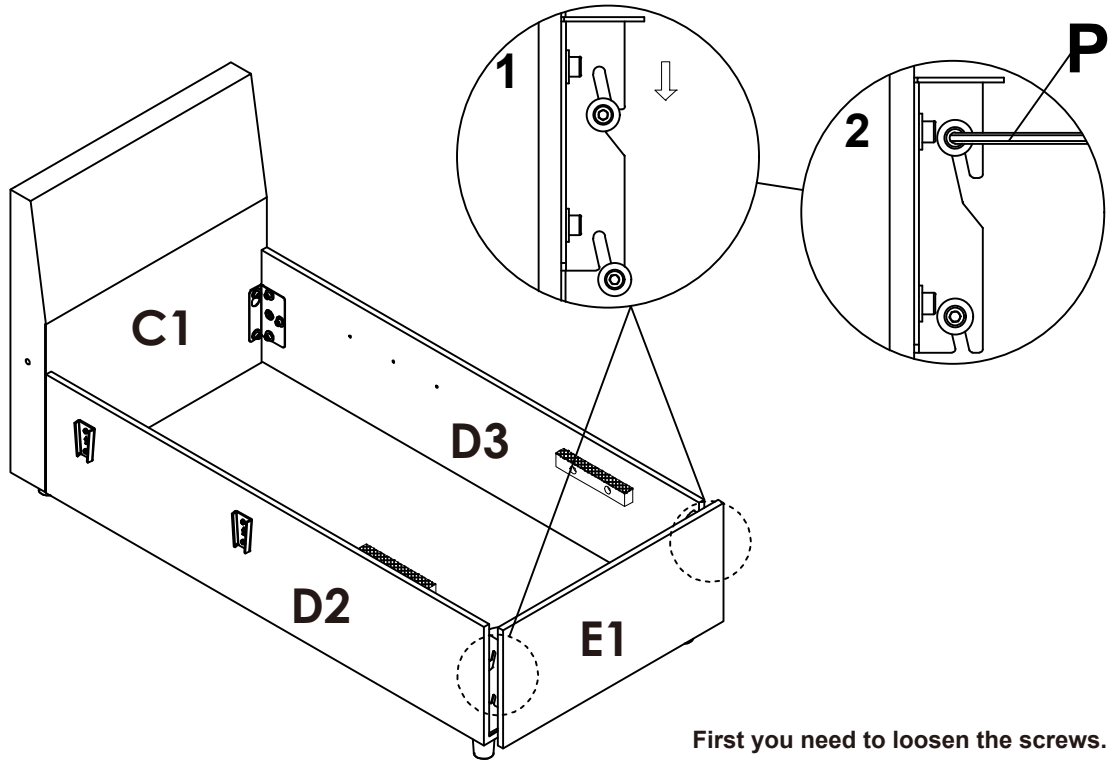

First you need to loosen the screws.



P x 1PC

## STEP 10

Note: The accessories should be distinguished between left and right, and the screws should be tightened after installation.

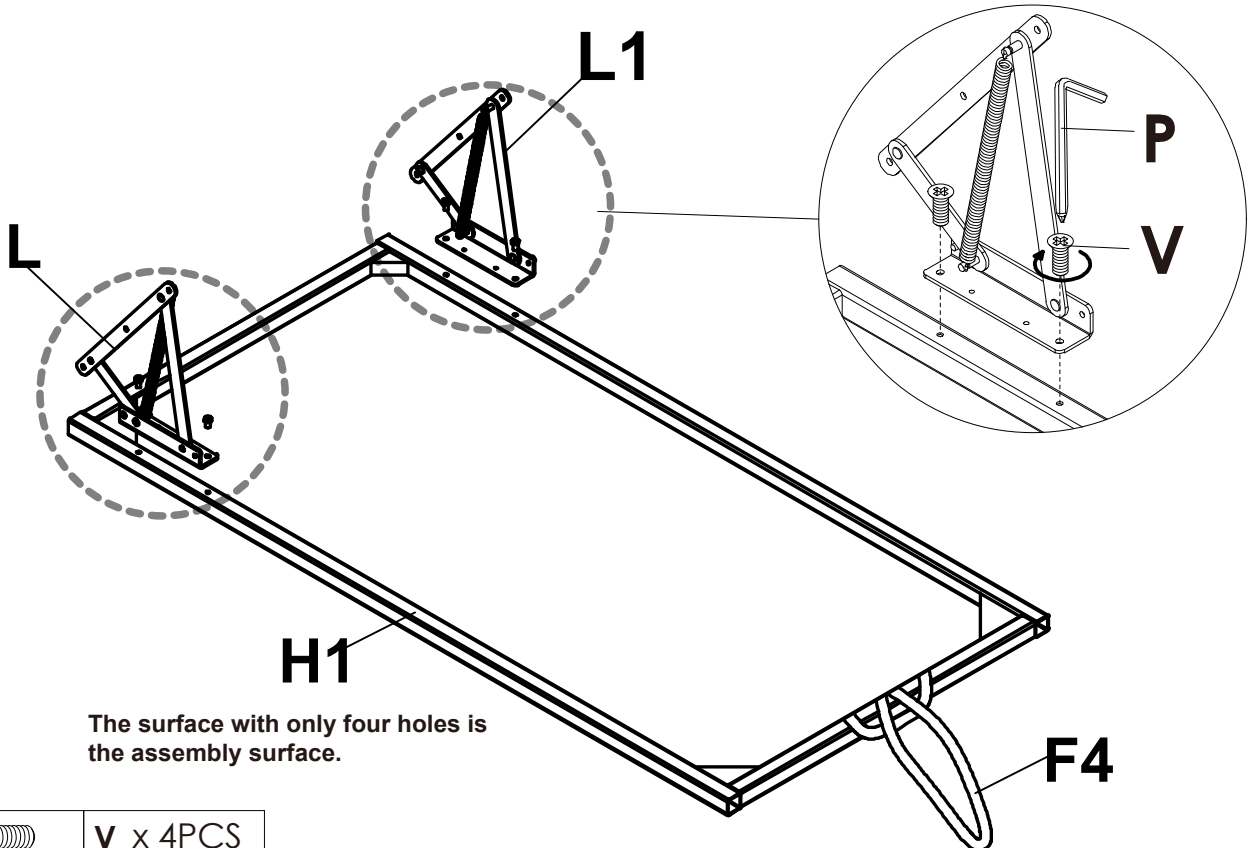

The surface with only four holes is the assembly surface.



V x 4PCS



P x 1PC

# Assembly Steps(EN)

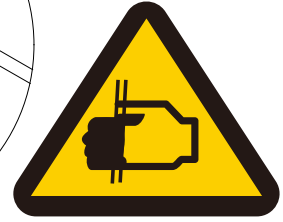
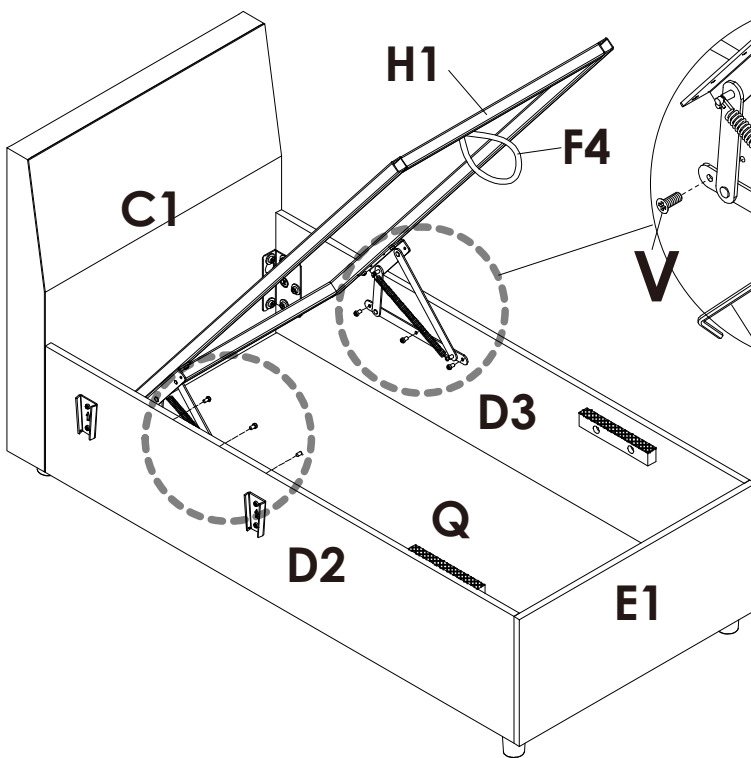

## STEP 11

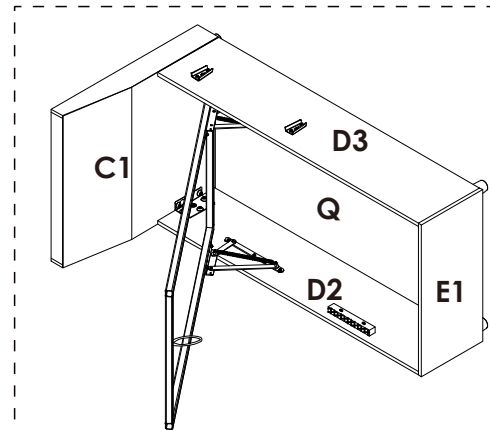

WARNING:HANDS PINCHING



Note:Easier to install when tilted

	V x 6PCS
	P x 1PC

## STEP 12

Place the **A1** in the second position and note that the Nylon Fastener side is facing up

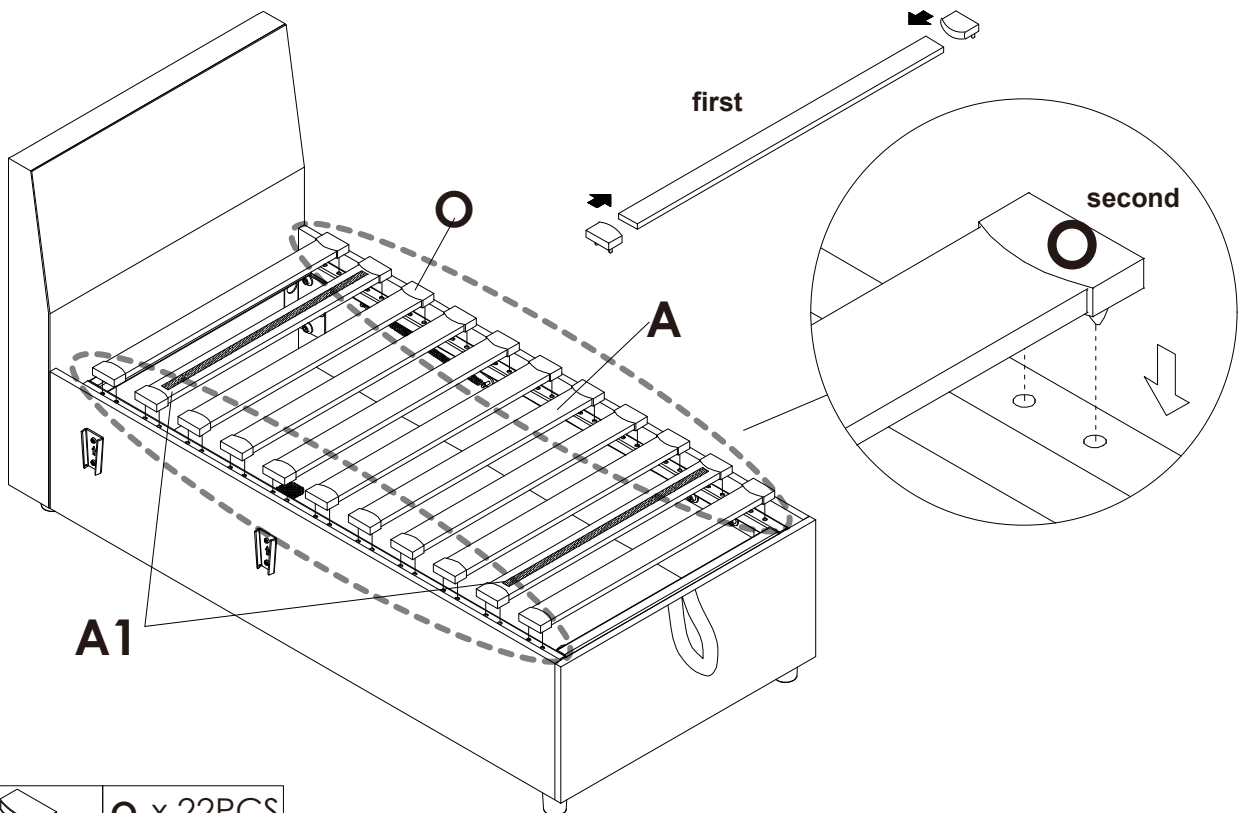

	O x 22PCS
---	-----------

# Main Structure Accessories

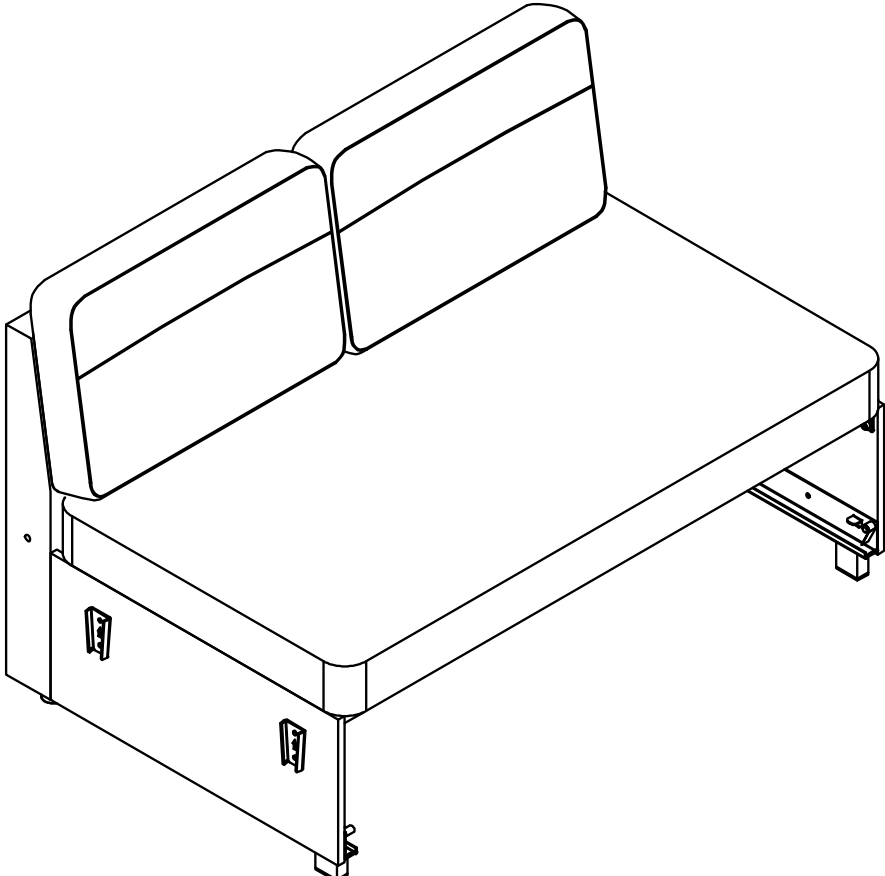
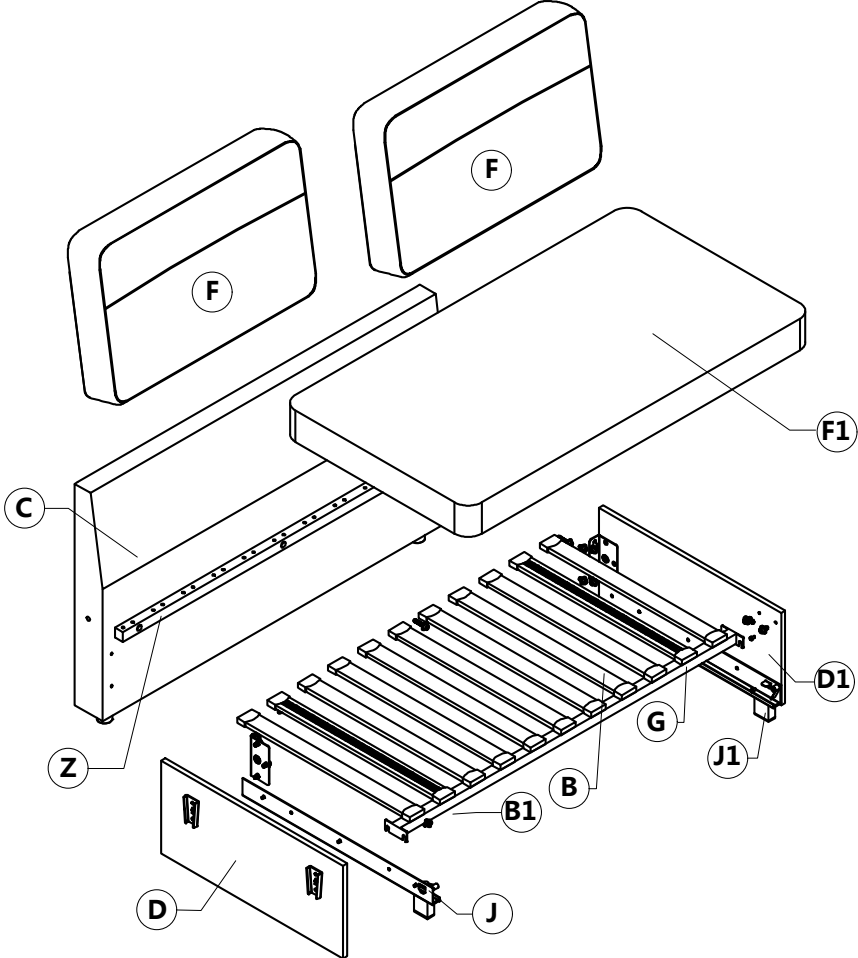

TWO SEATS

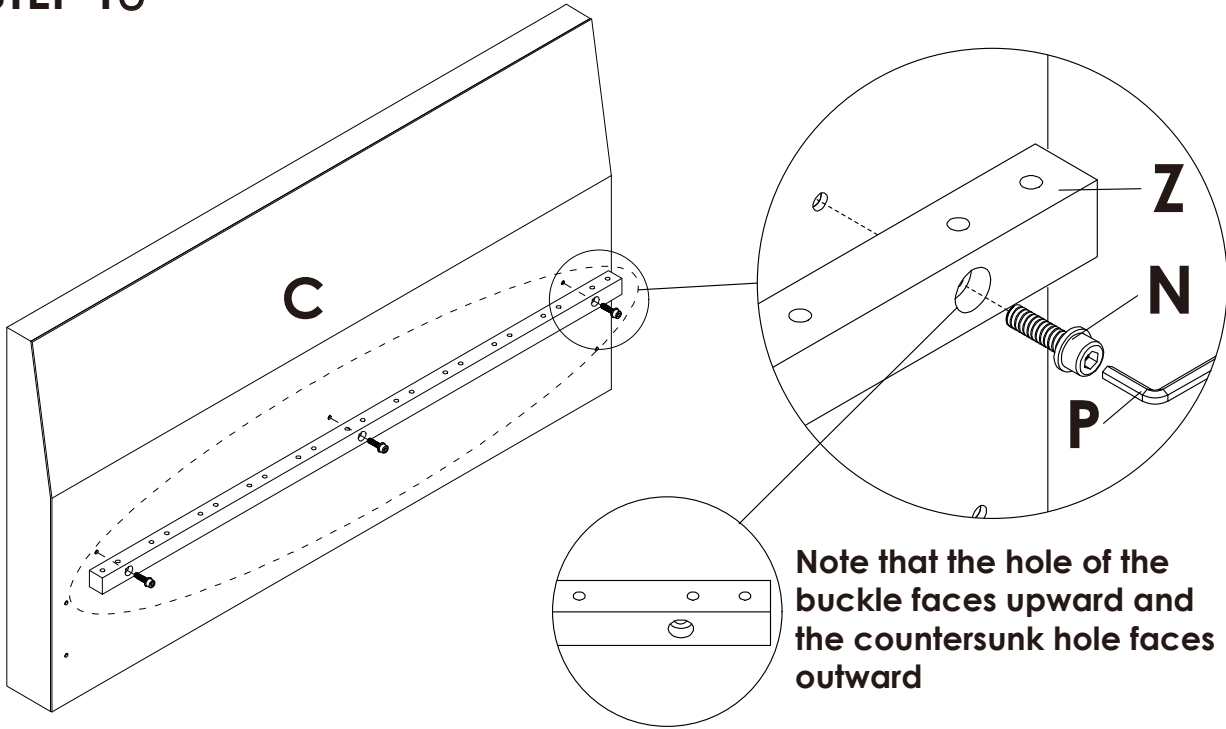

# Assembly Steps(EN)

## STEP 13



	N x 3PCS
	P x 1PC

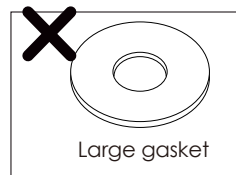
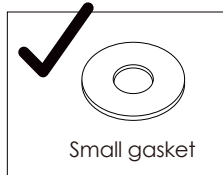

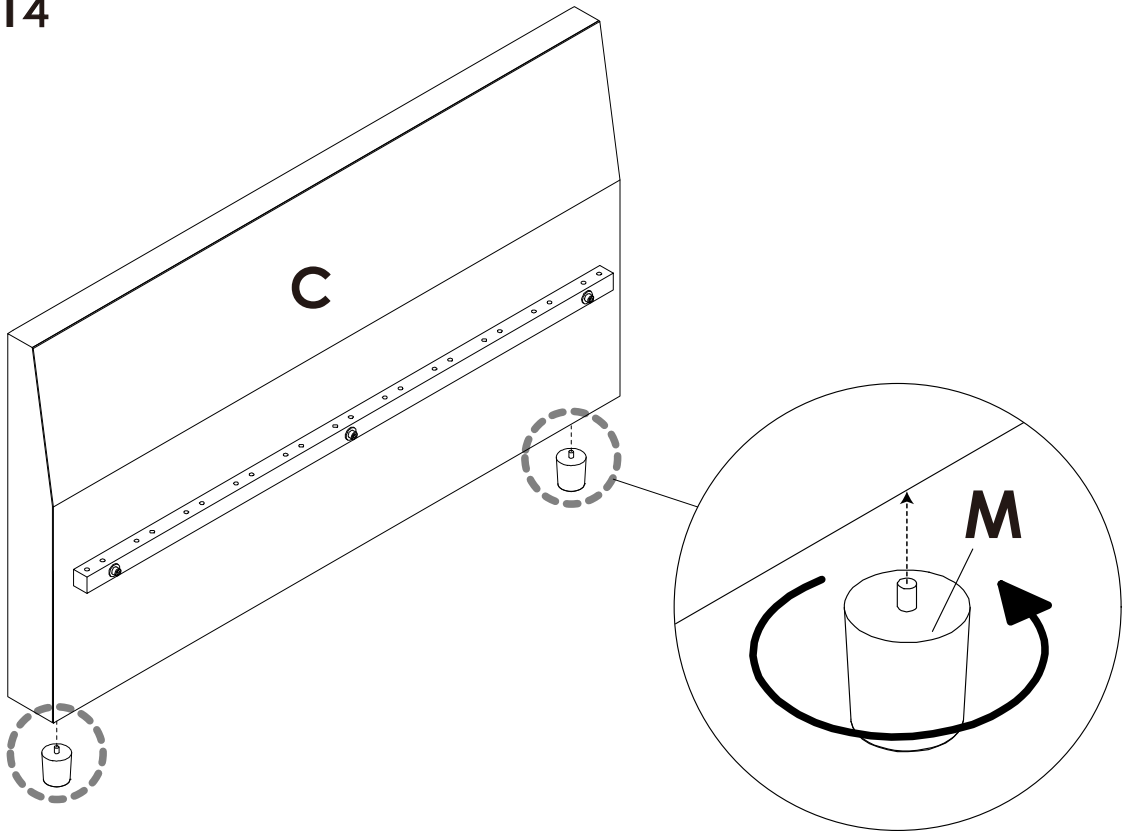

## STEP 14

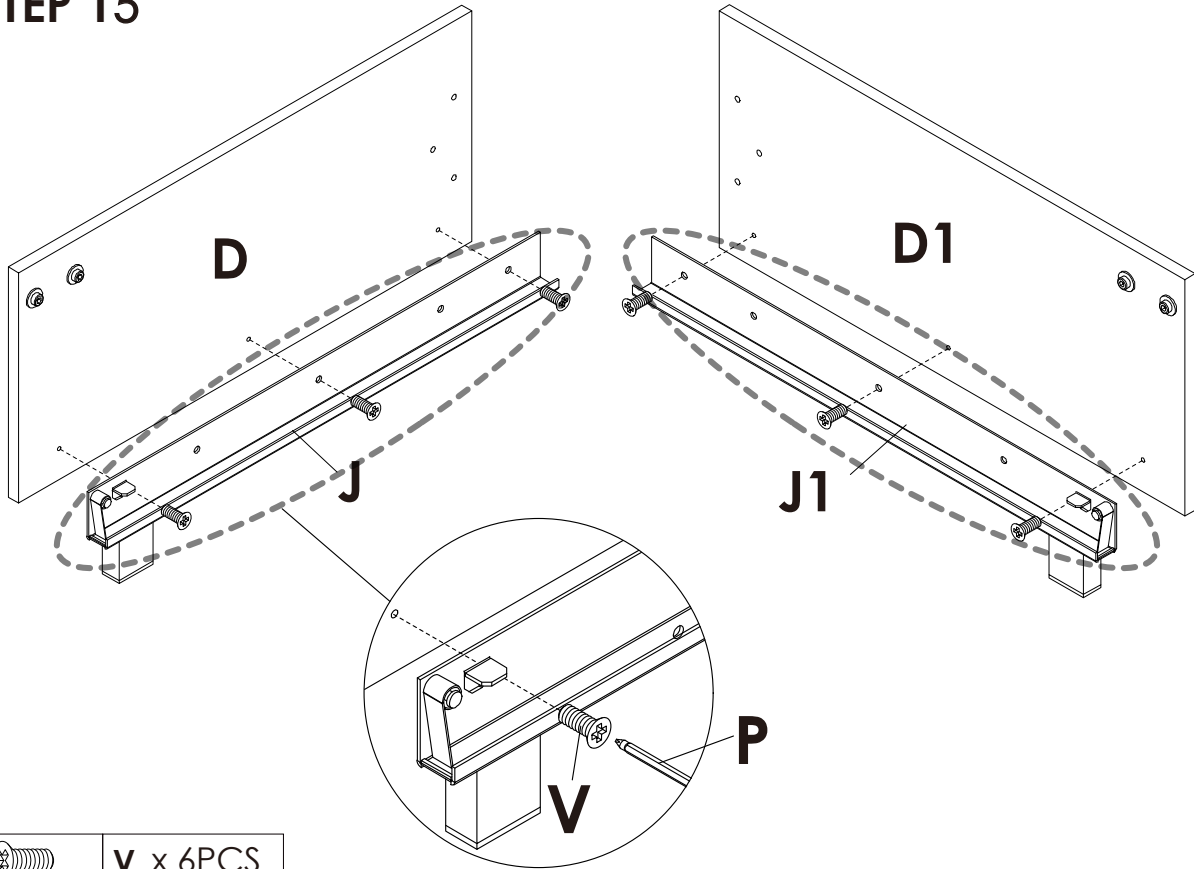

# Assembly Steps(EN)

## STEP 15





	V x 6PCS
	P x 1PC

## STEP 16

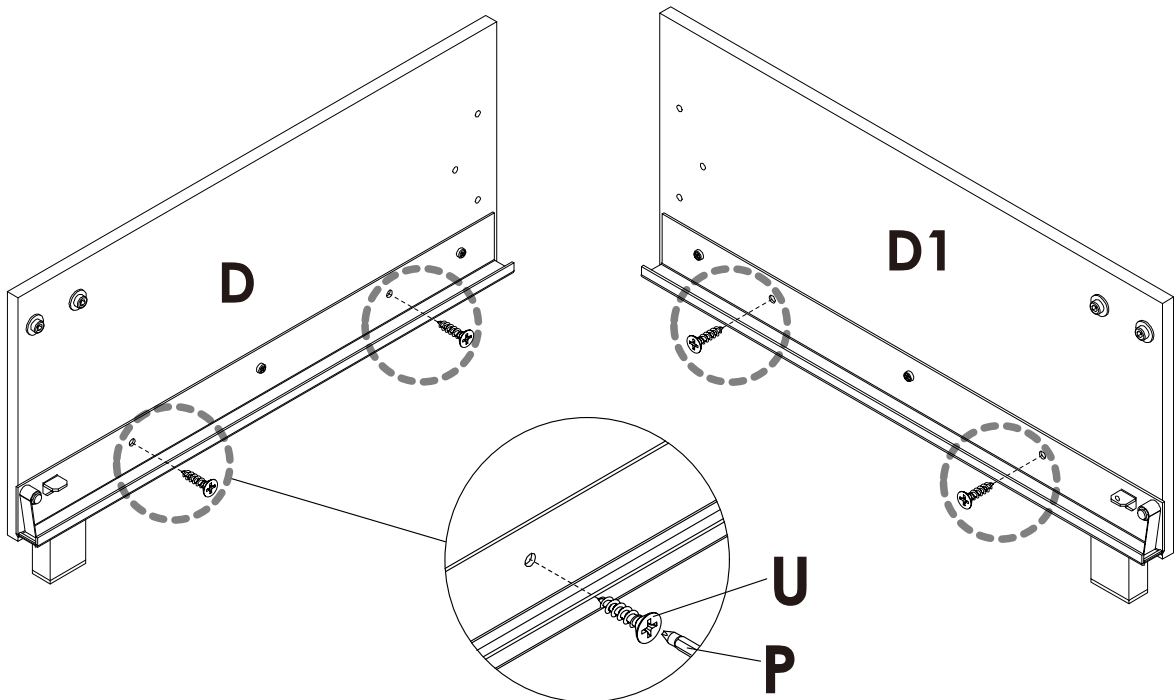
Reinforcing lock with self-tapping screws







	U x 4PCS
	P x 1PC

**Tips:** Self-tapping screw is an auxiliary reinforcement function, you can choose to reinforce or not.

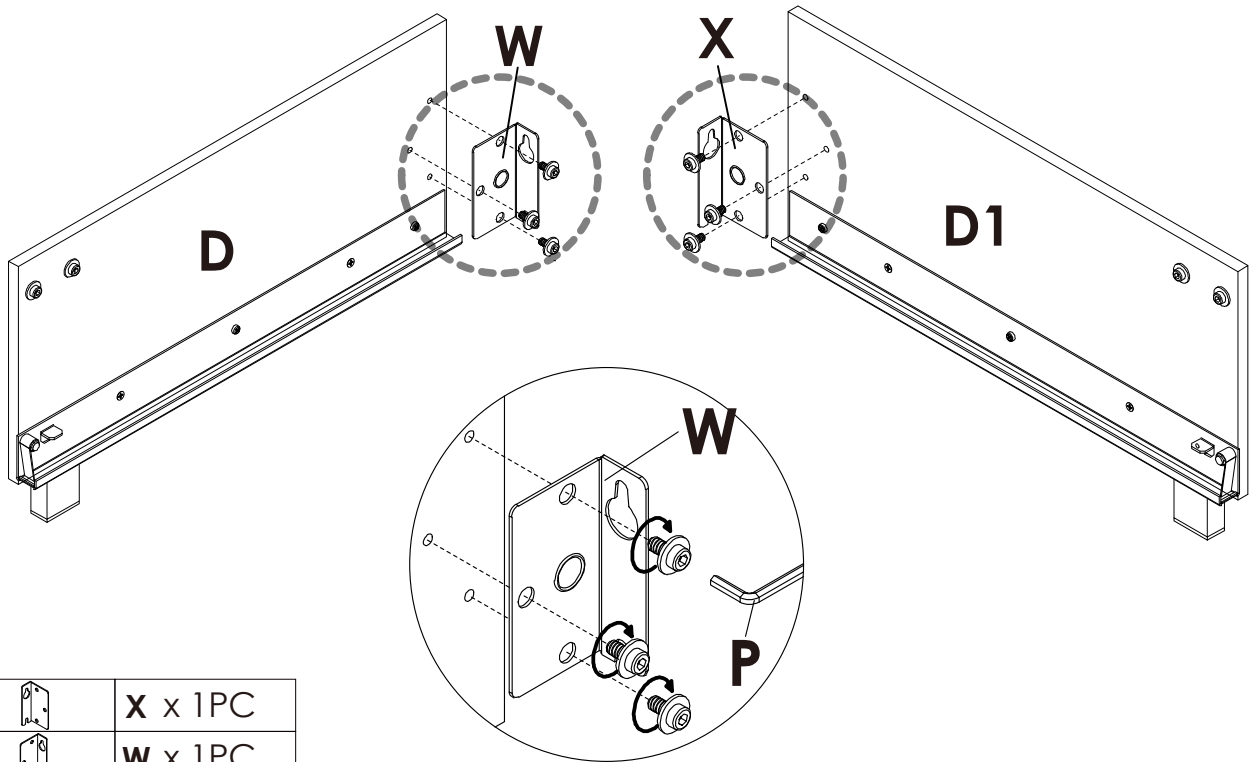
## Assembly Steps(EN)

**STEP 17** First, loosen the screws properly for a better fit.



	X x 1PC
	W x 1PC
	P x 1PC

**STEP 18** There are 2 screws on the left and right bottom of the C board. It is recommended to loosen half of them and then install the mounting plate, and then lock the screws.

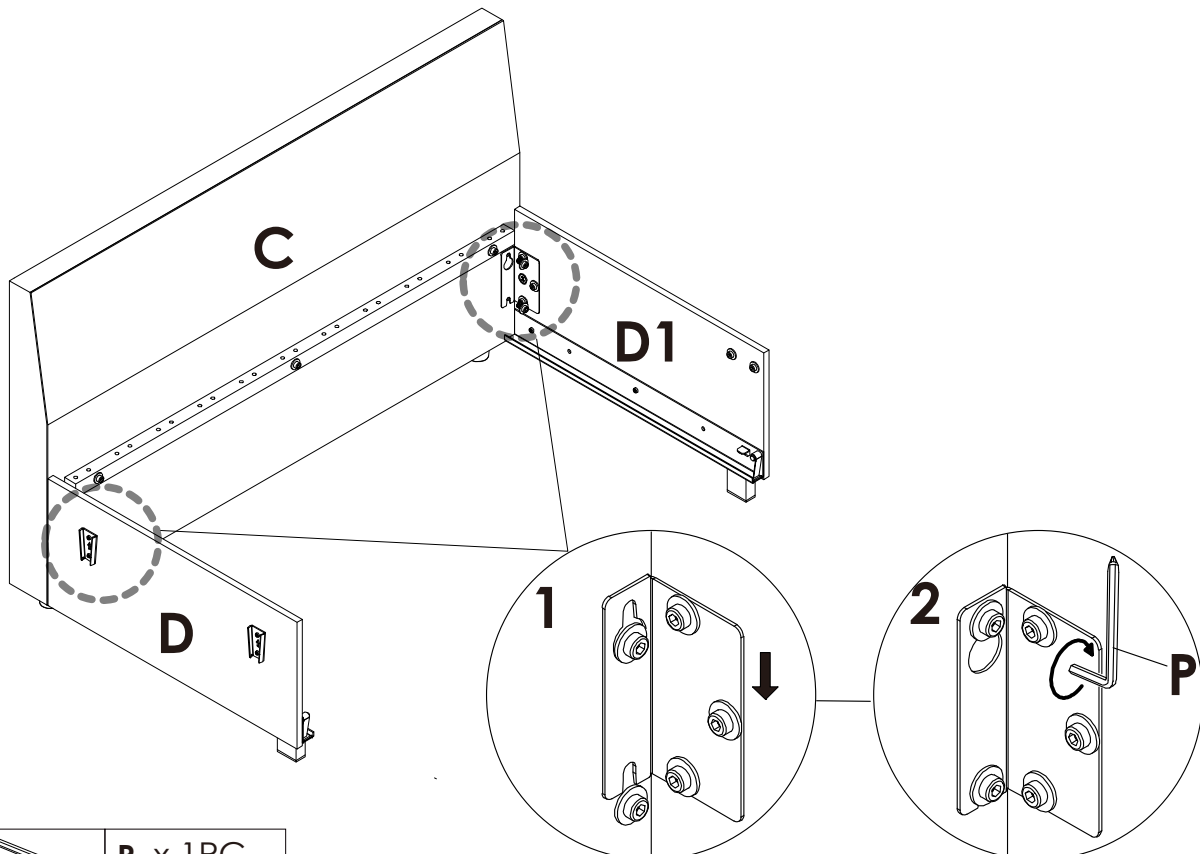

	P x 1PC
---	---------

## Assembly Steps(EN)

**STEP 19** First, loosen the screws properly for a better fit.

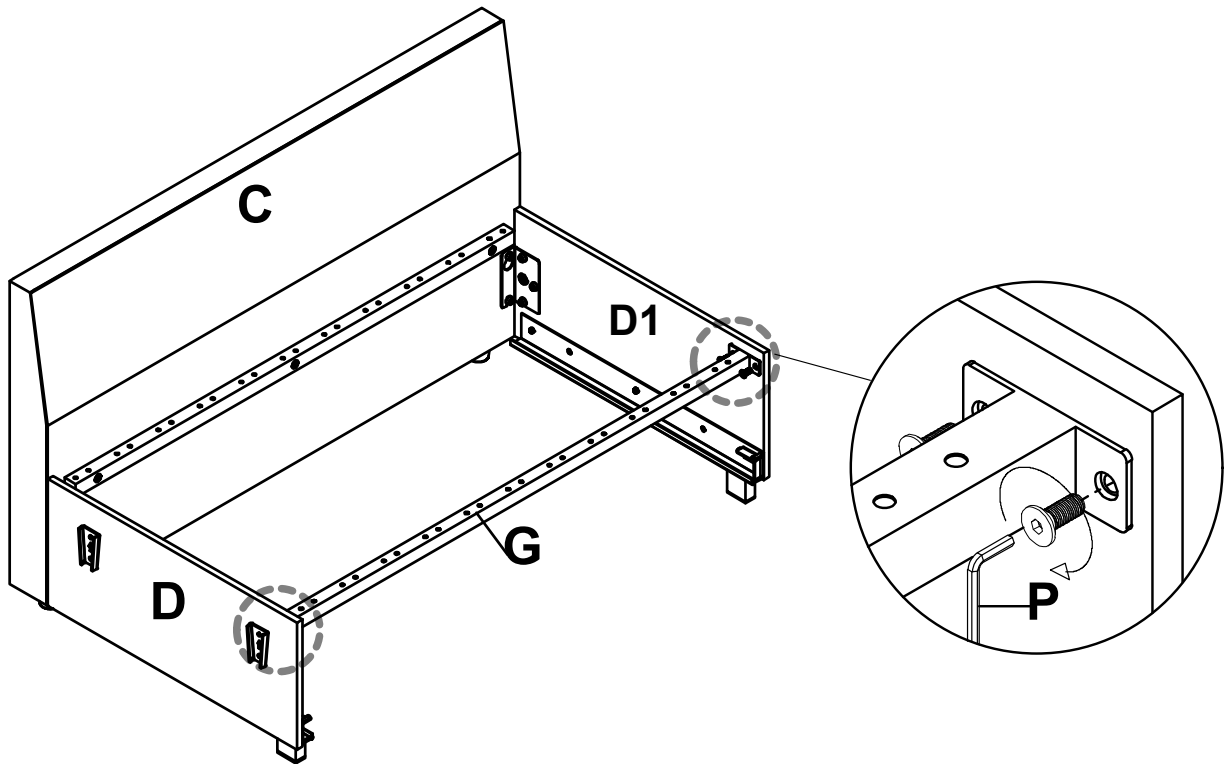

P x 1PC

**STEP 20** Place the **B1** in the second position and note that the Velcro side is facing up

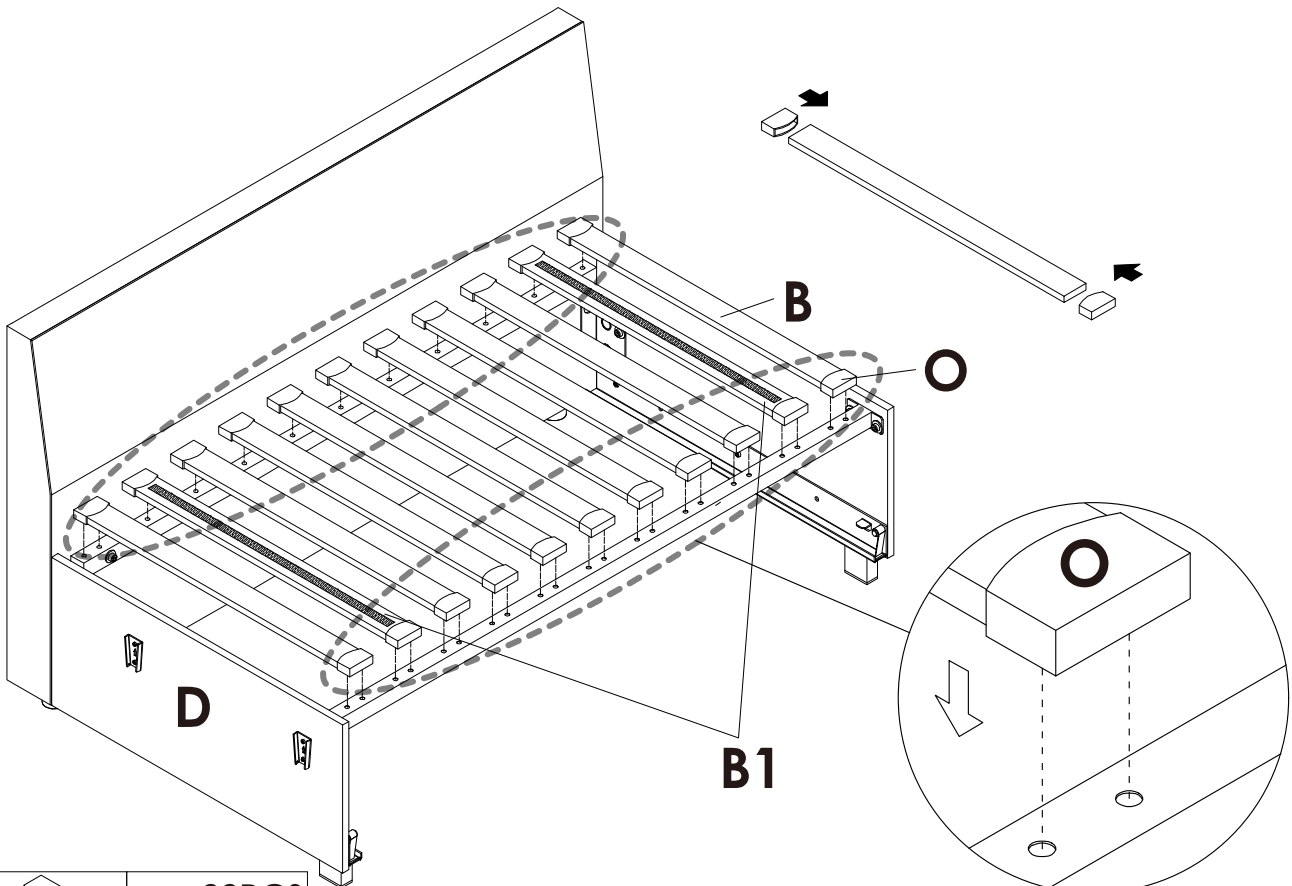

O x 22PCS

# Main Structure Accessories

## PULL-OUT

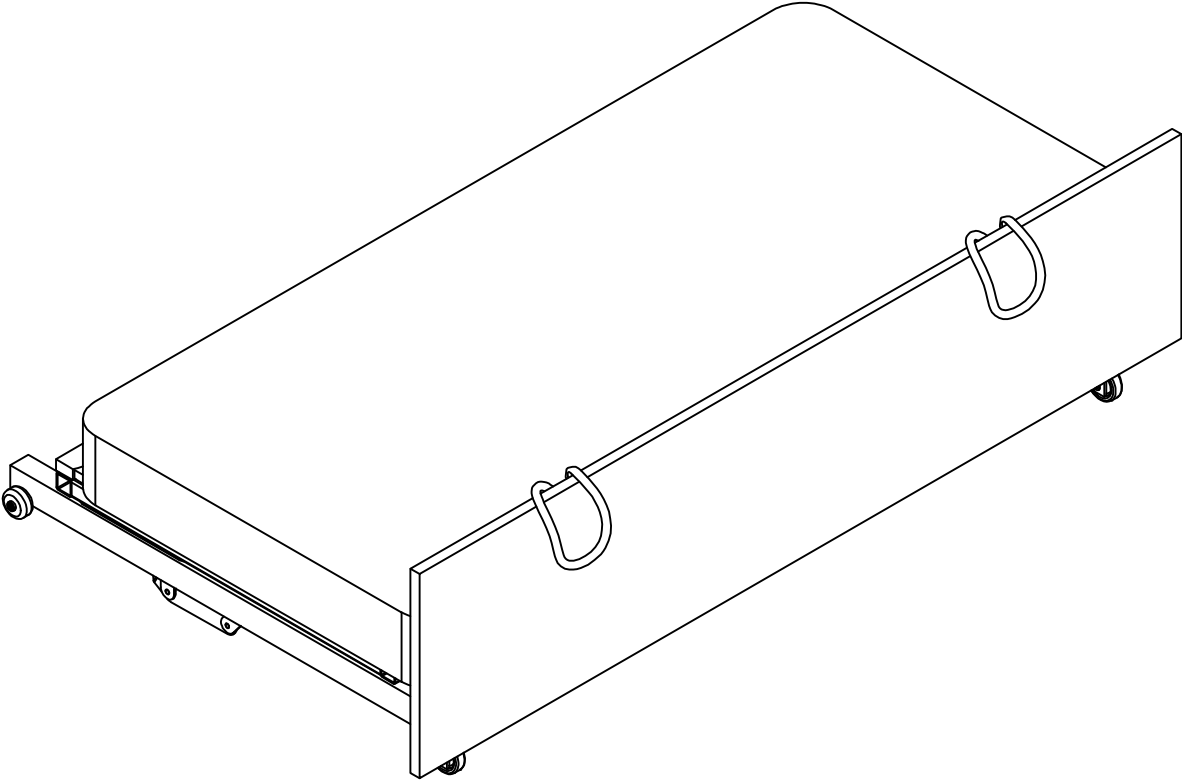
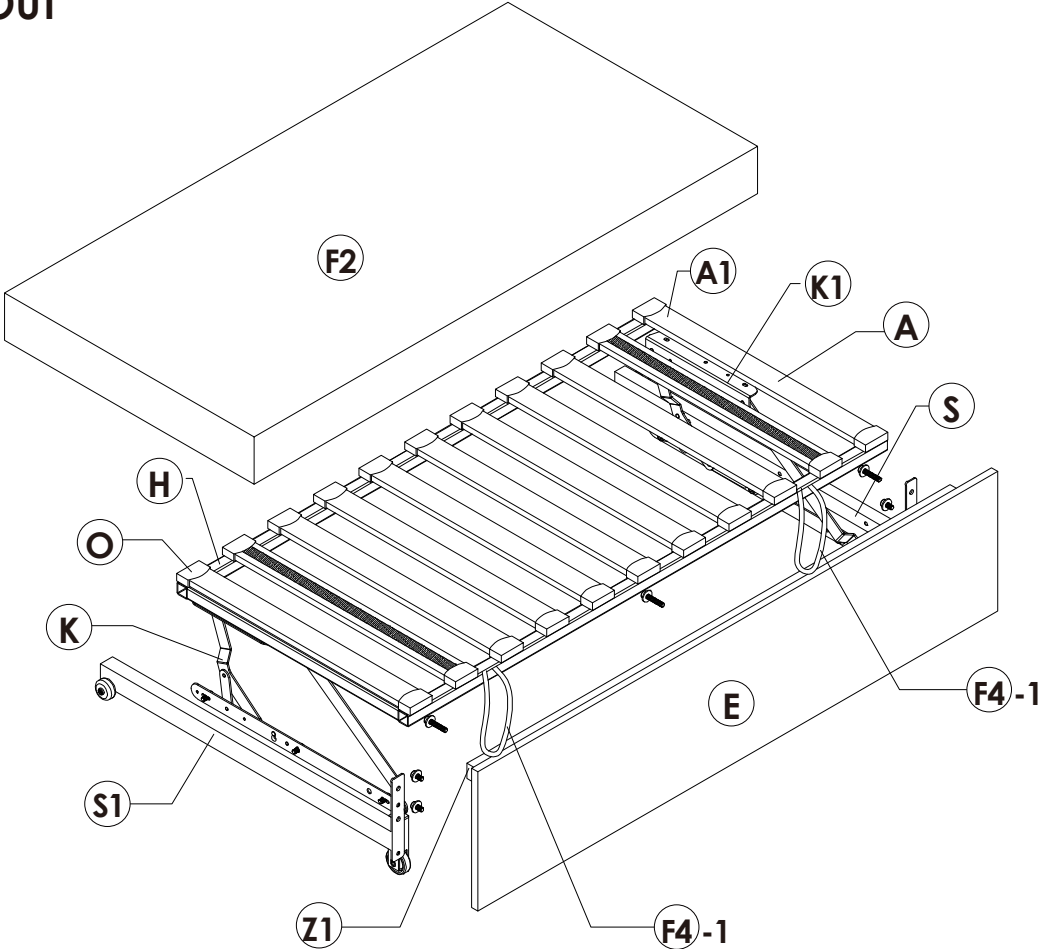

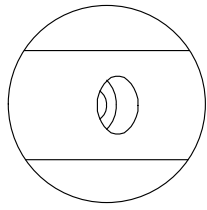

## Assembly Steps(EN)

### STEP 21

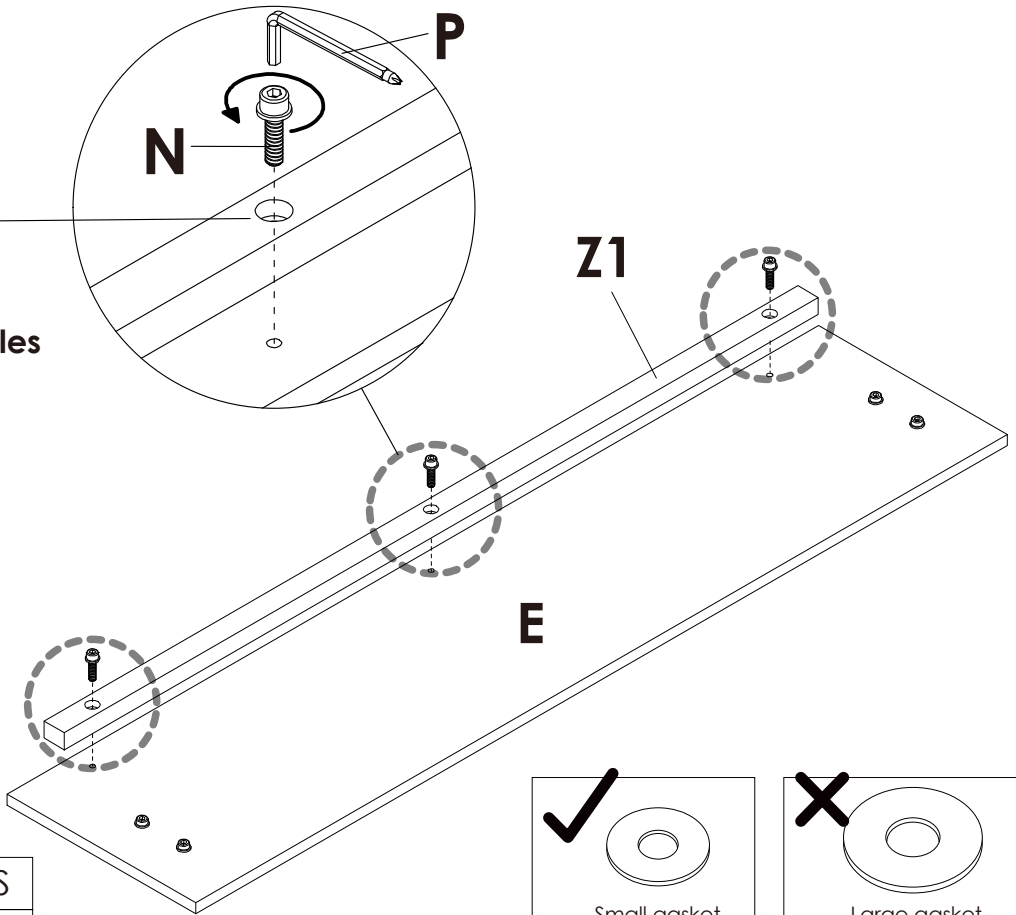

Countersunk holes  
face outward.



	<b>N</b> x 3PCS
	<b>P</b> x 1PC

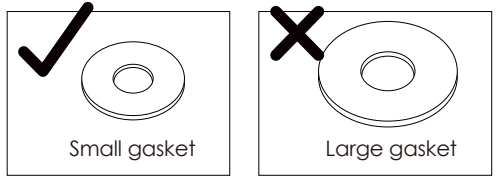

### STEP 22

First, loosen the screws properly for a better fit.

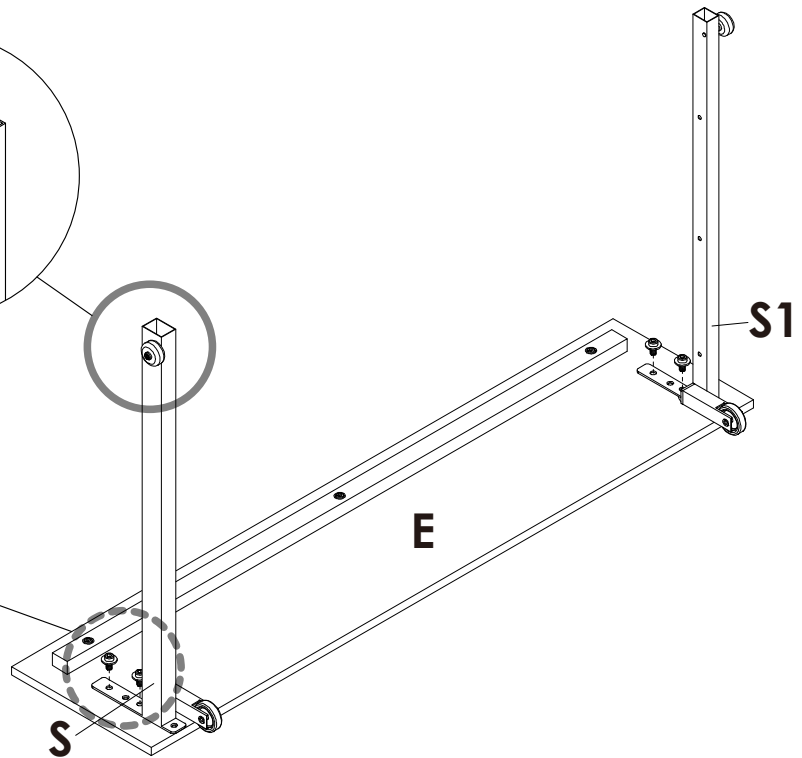
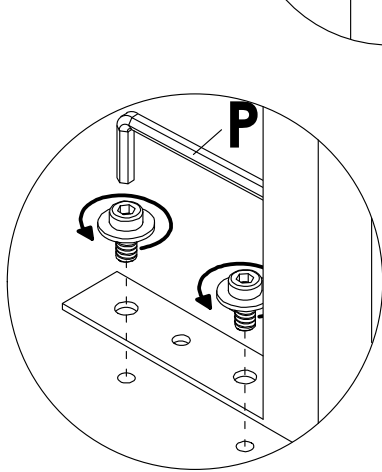
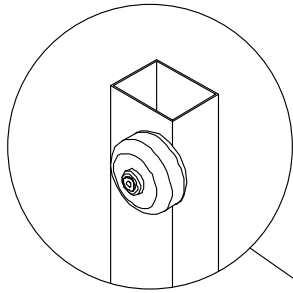



	<b>P</b> x 1PC
---	----------------

# Assembly Steps(EN)

## STEP 23

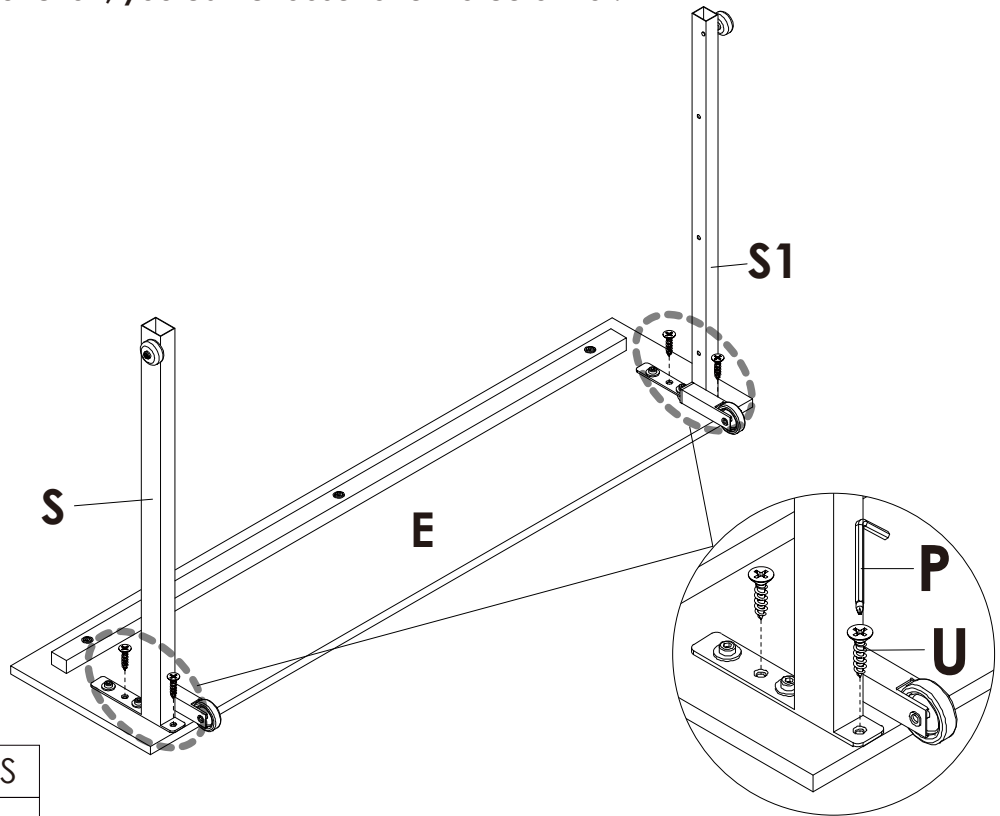

Tips: Self-tapping screw is an auxiliary reinforcement function, you can choose to reinforce or not.

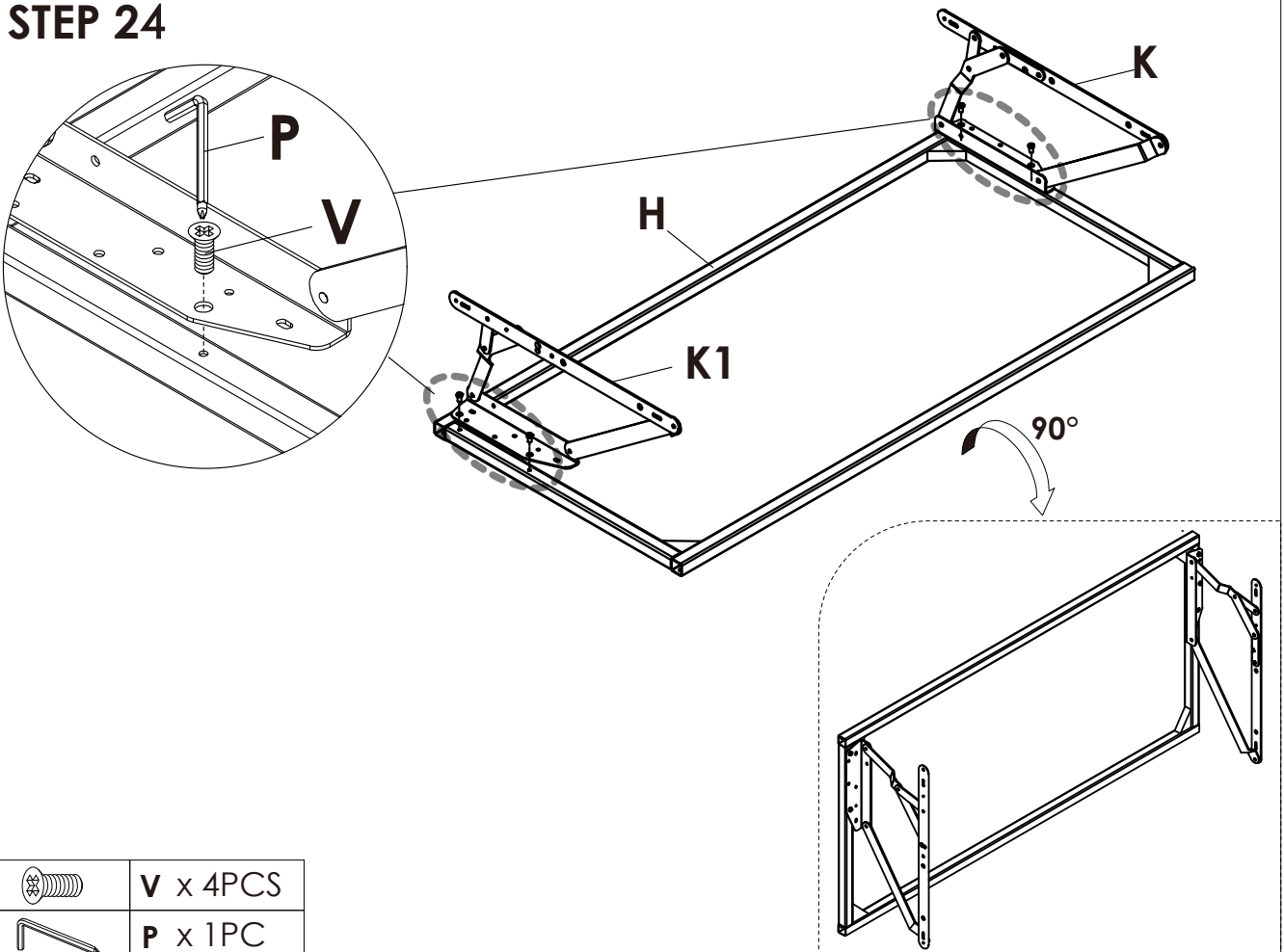

	U x 4PCS
	P x 1PC

## STEP 24





	V x 4PCS
	P x 1PC

# Assembly Steps(EN)

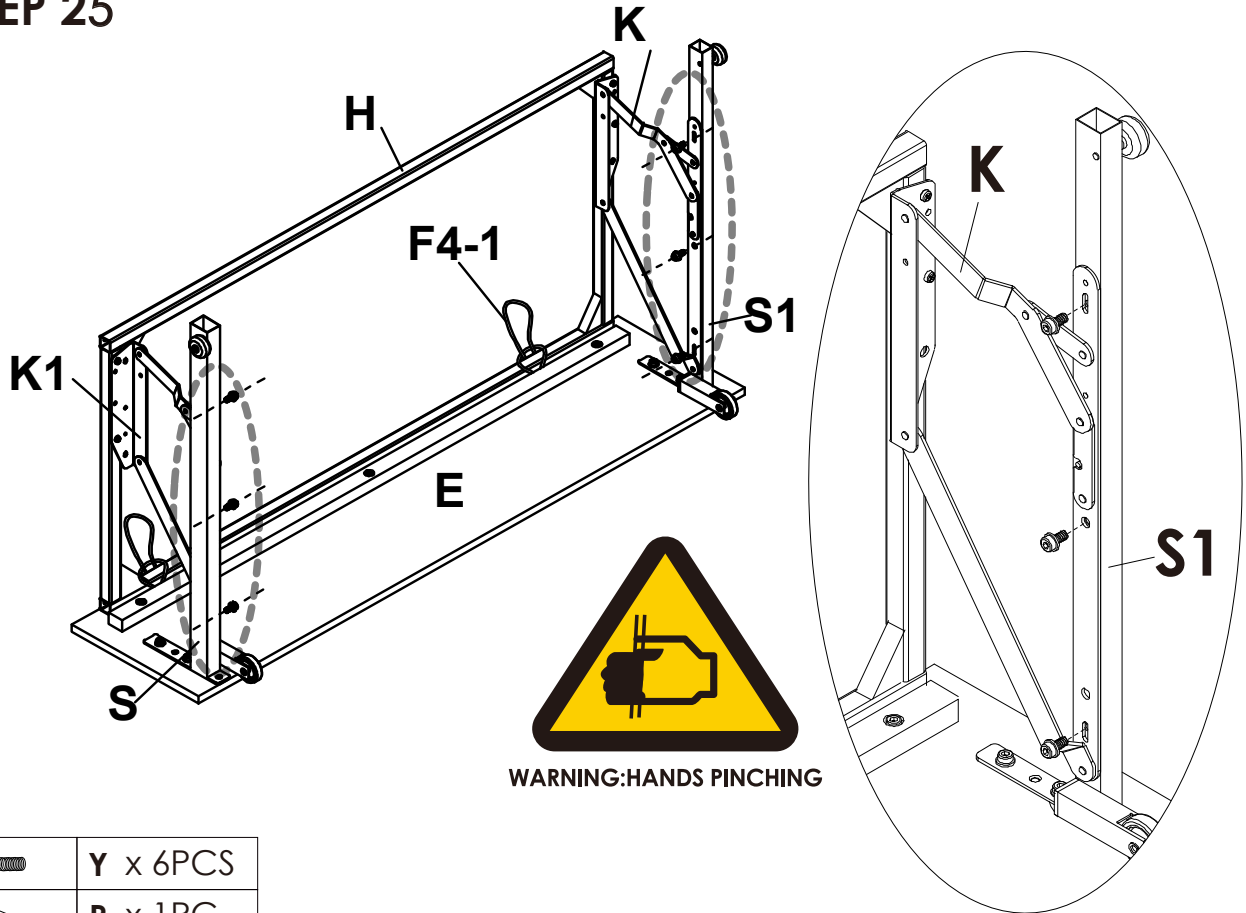
## STEP 25



	Y x 6PCS
	P x 1PC

## STEP 26

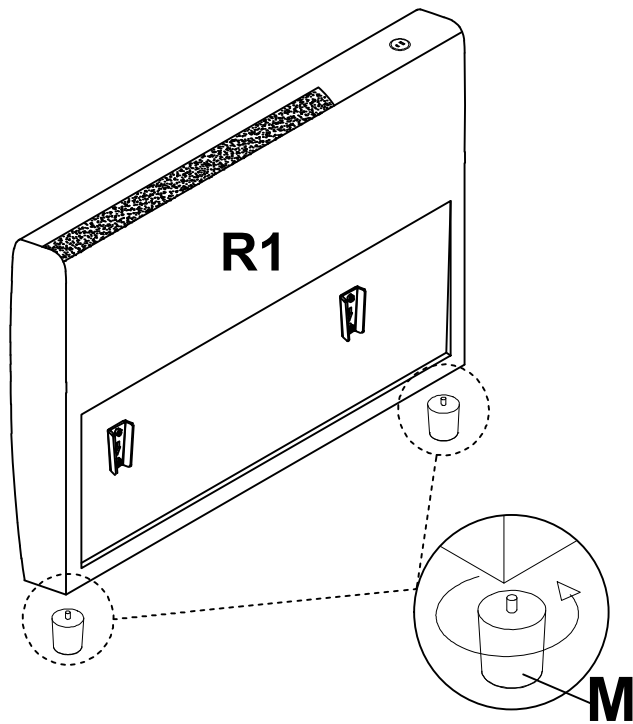

## Assembly Steps(EN)

### STEP 27

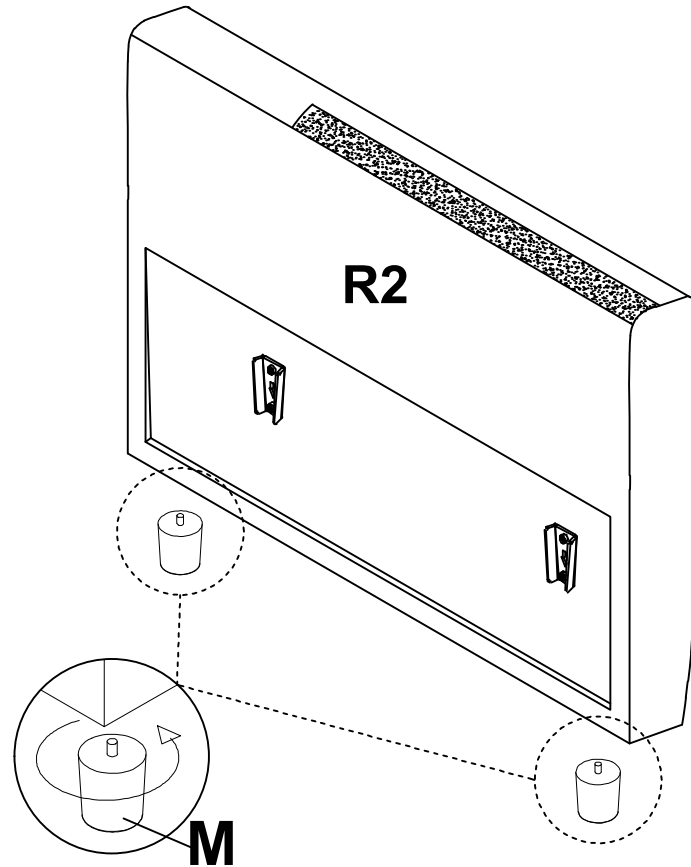

### Assembly Option ① STEP 28

It is recommended that two people install it, one person lifts the C board and connects.

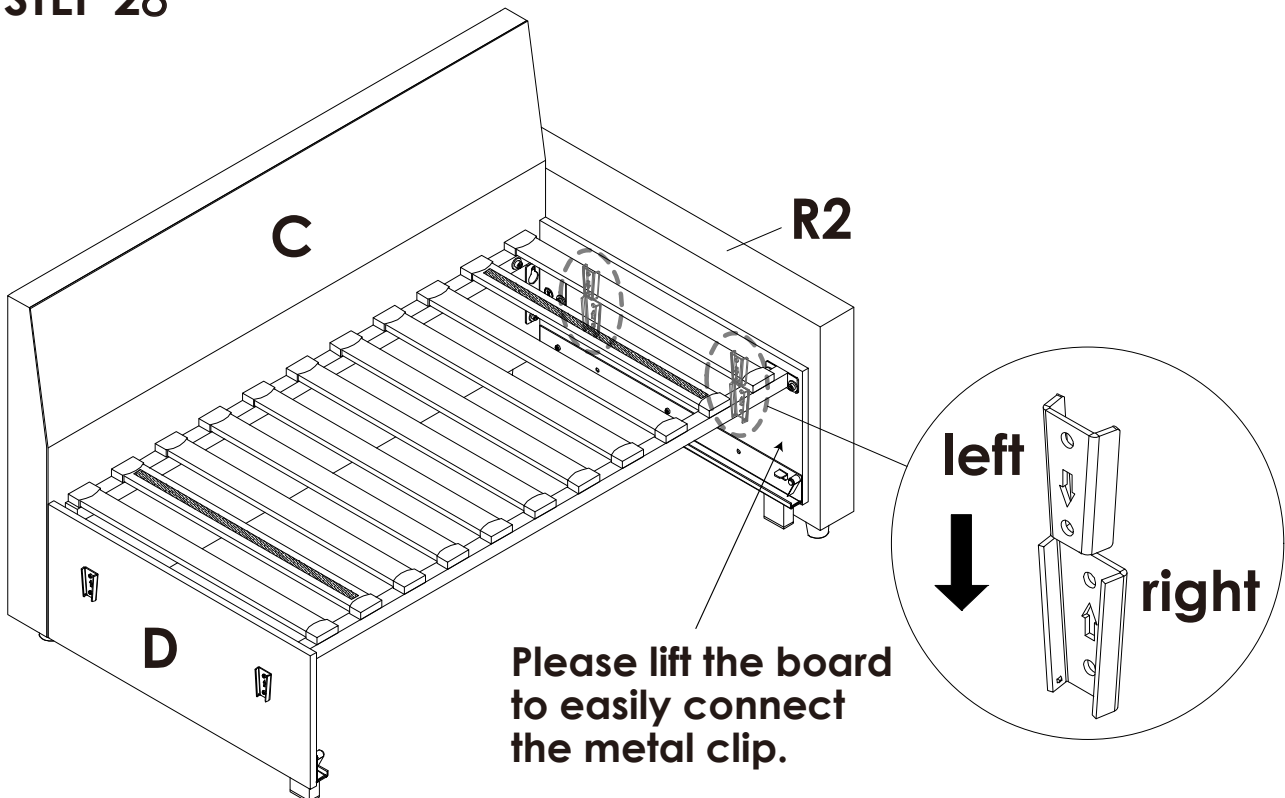

## Assembly Steps(EN)

### Assembly Option ① STEP 29

Please lift the board to easily connect the metal clip.

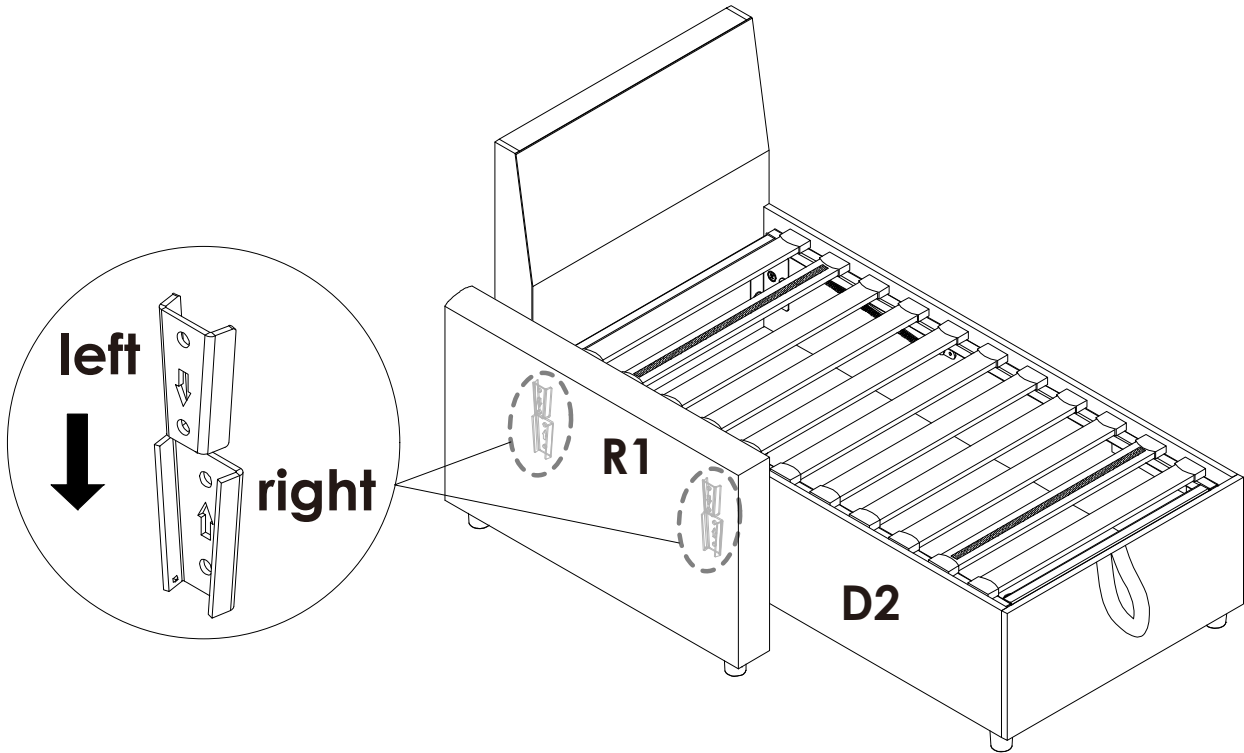

### Assembly Option ① STEP 30

Please lift the board to easily connect the metal clip.

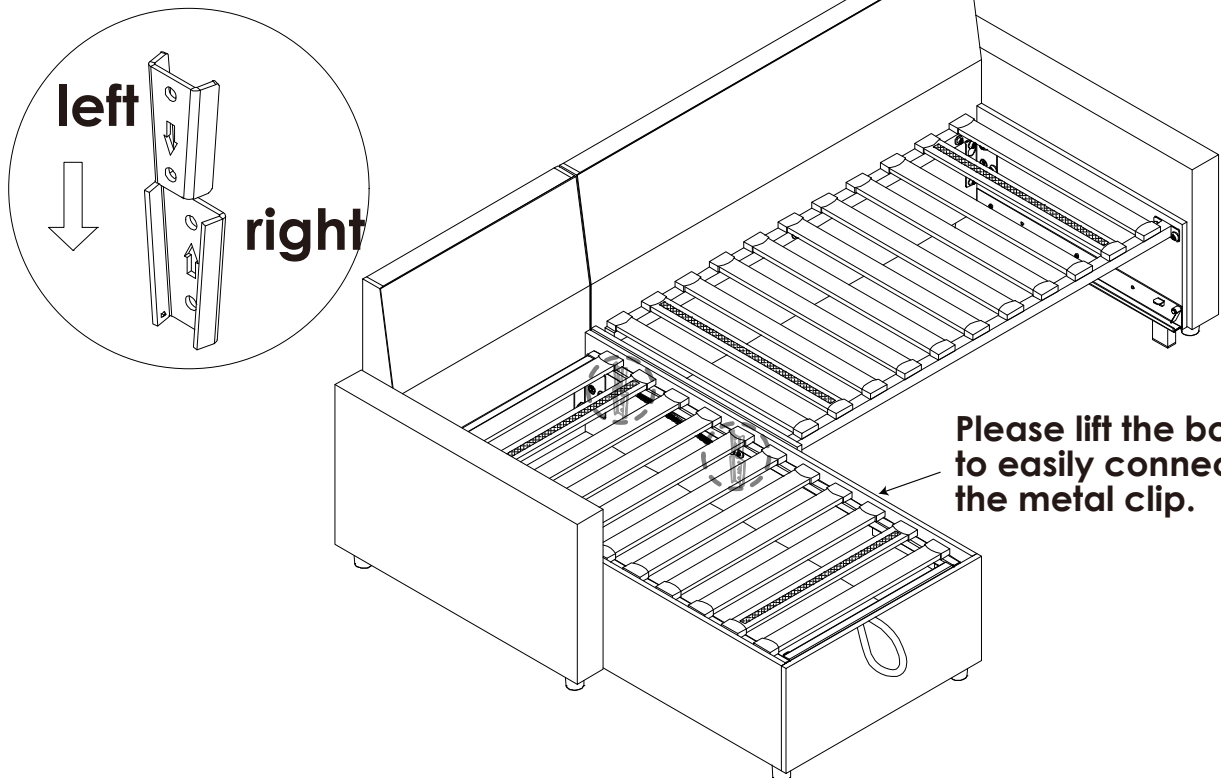

# Assembly Steps(EN)

## Assembly Option ①

### STEP 31

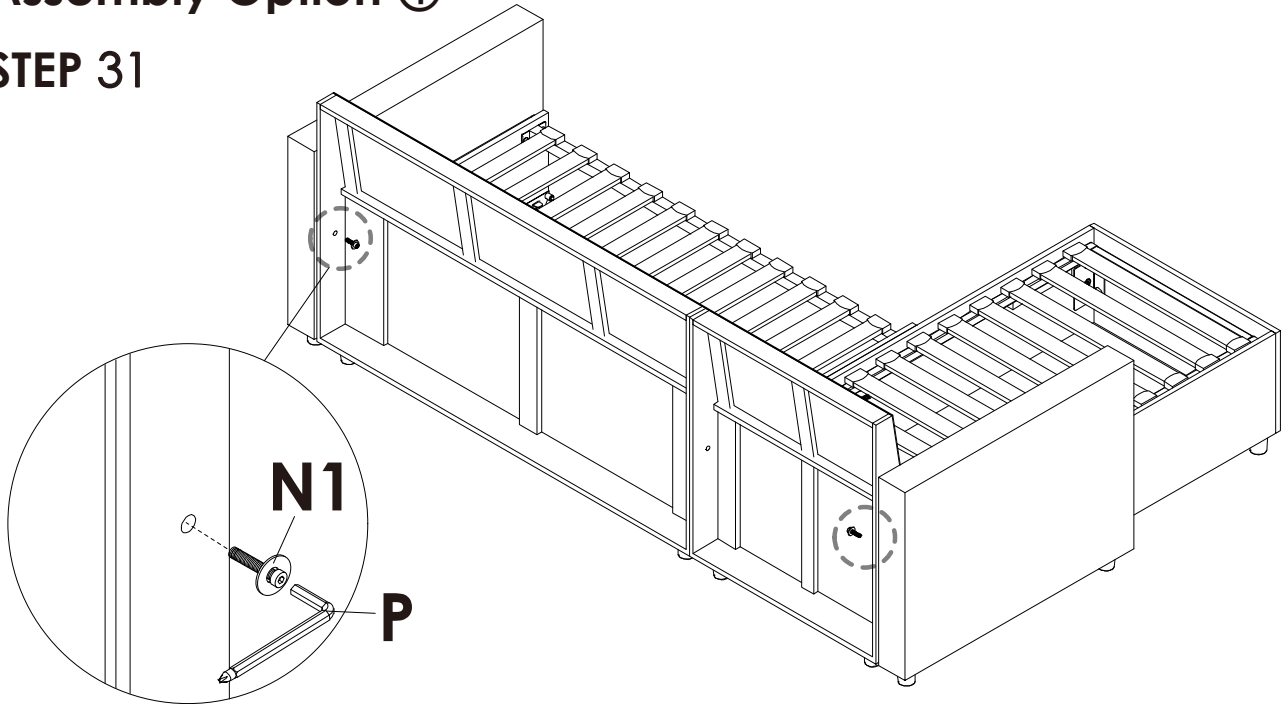

Secure with locking screws

	N1 x 2PCS
	P x 1PC

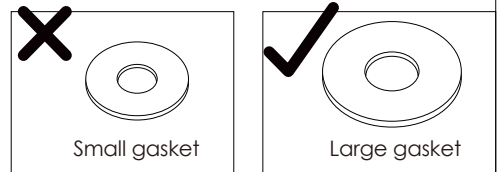

## Assembly Option ①

### STEP 32

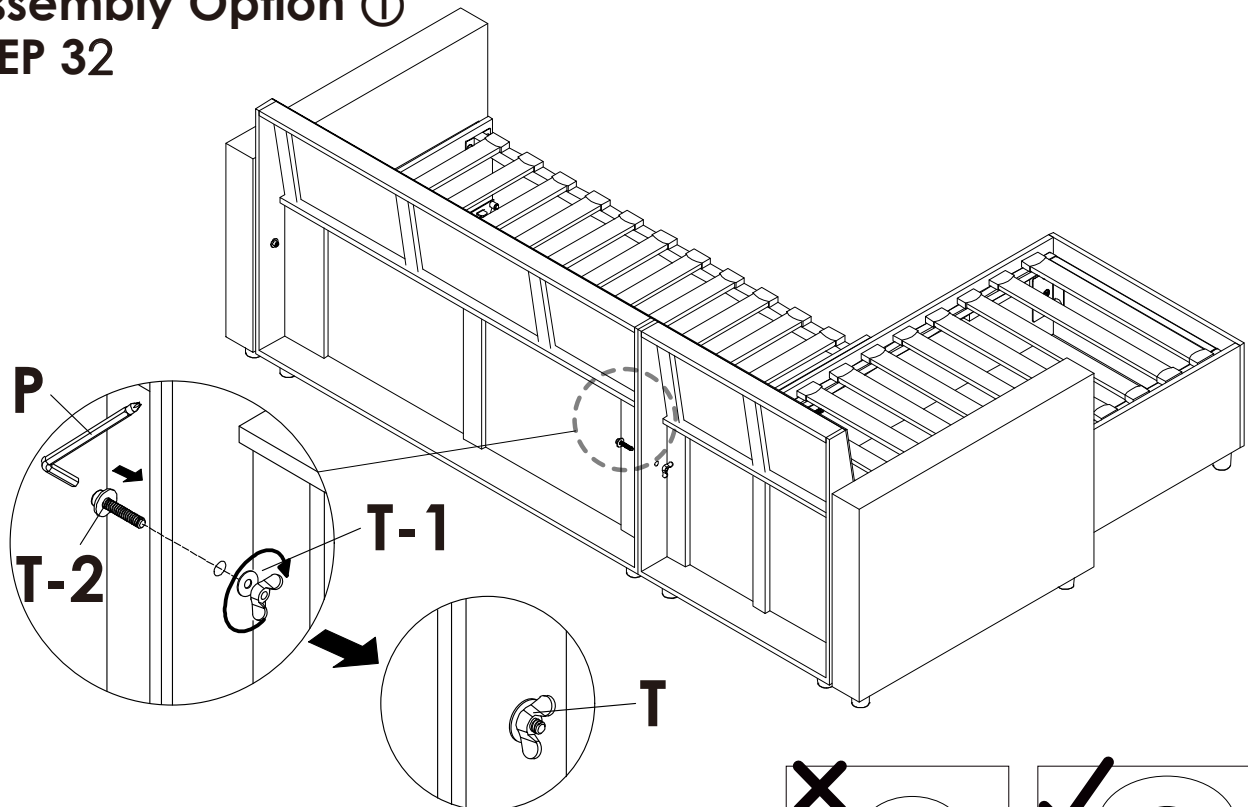

	P x 1PC
	T x 1PC

Screw through hole and tighten with butterfly nut.

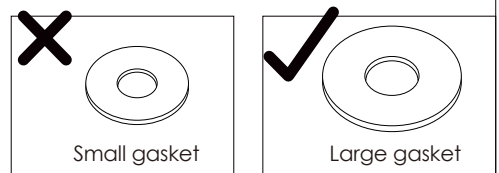

## Assembly Steps(EN)

### Assembly Option ①

#### STEP 33

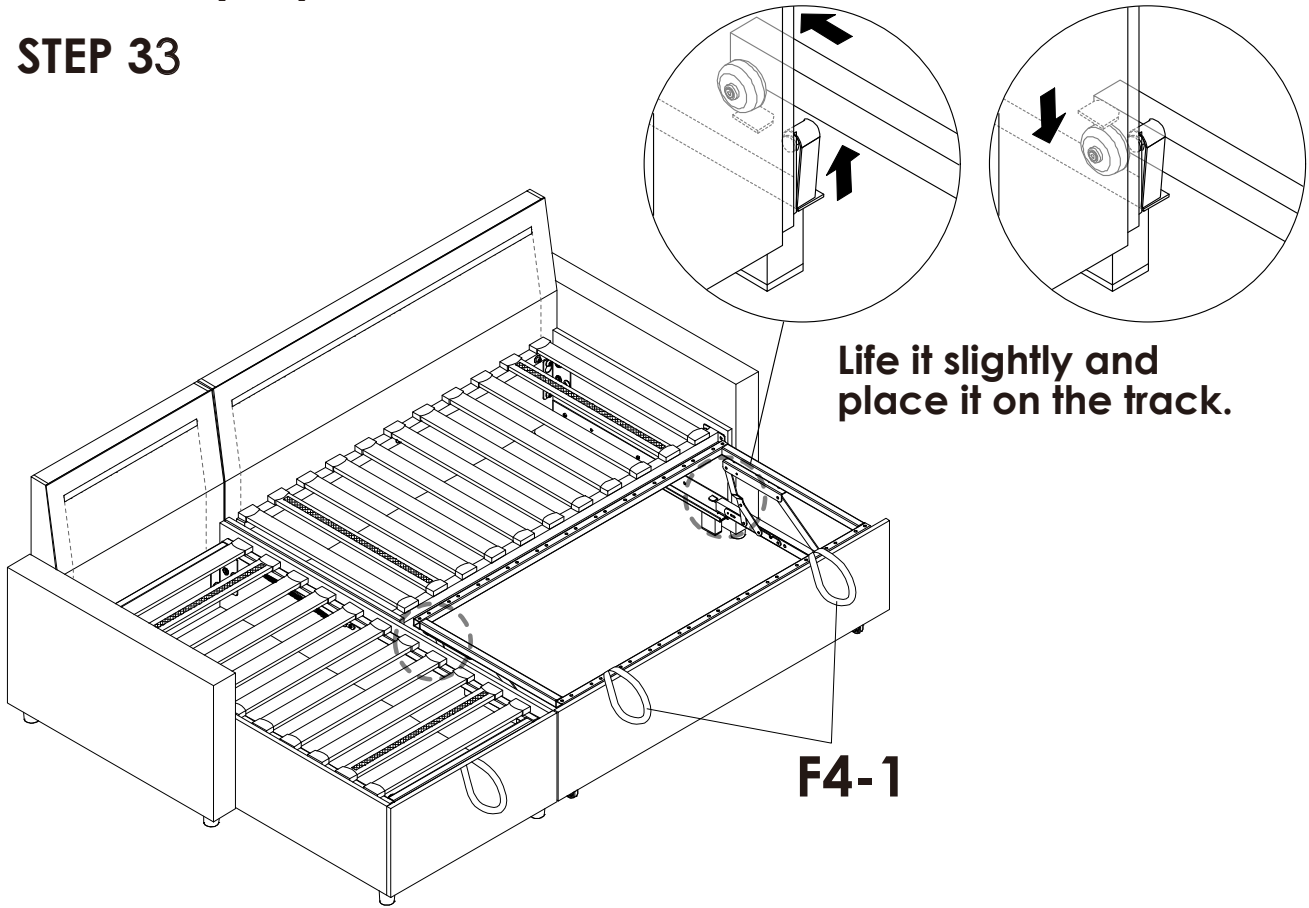

### Assembly Option ①

#### STEP 34

Place the A1 in the second position and note that the Nylon Fastener side is facing up.

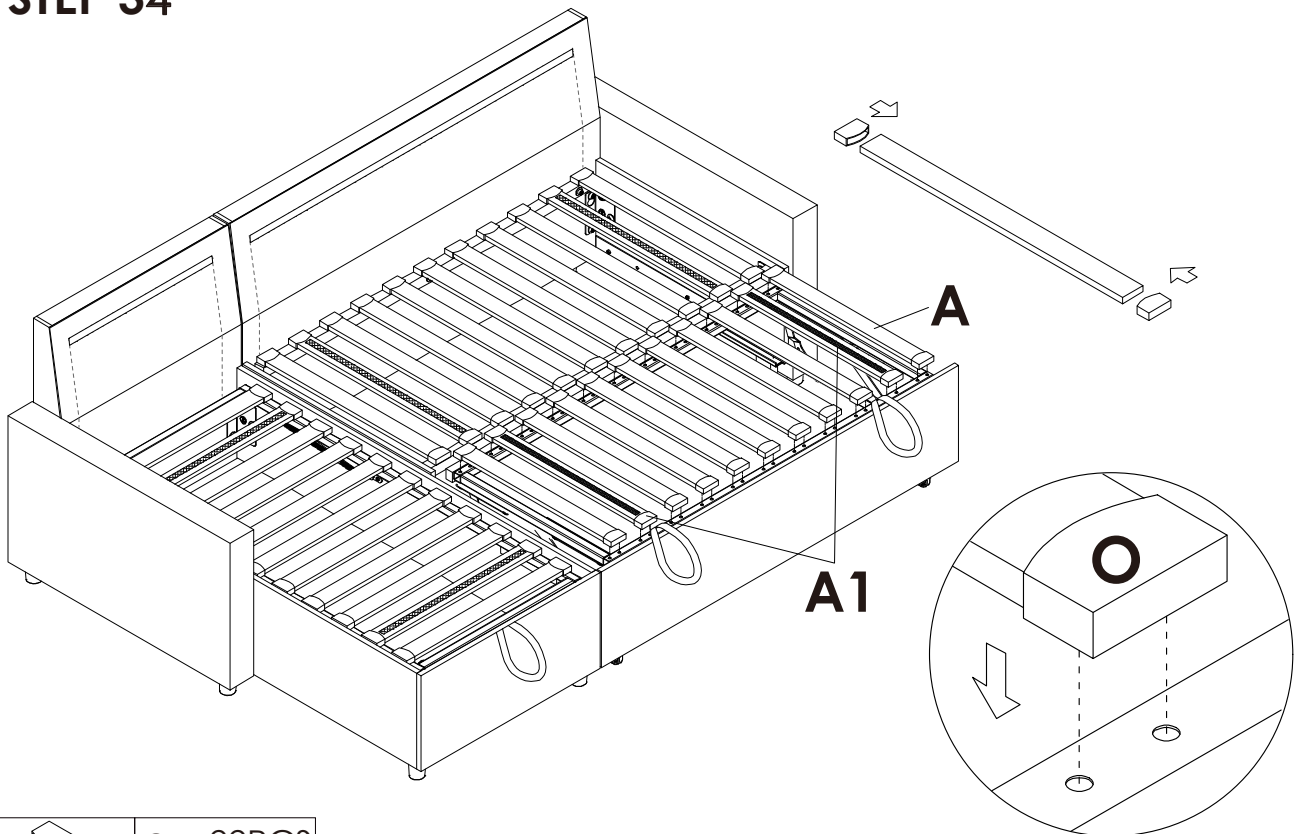

O x 22PCS

## Assembly Steps(EN)

### Assembly Option ①

#### STEP 35

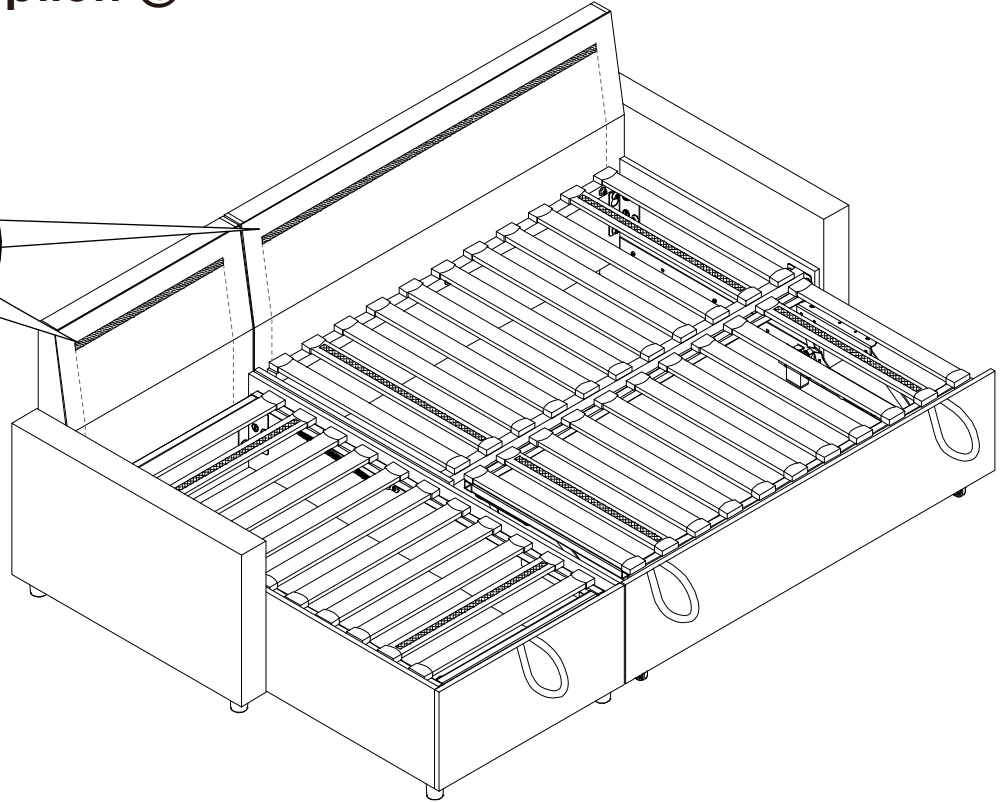
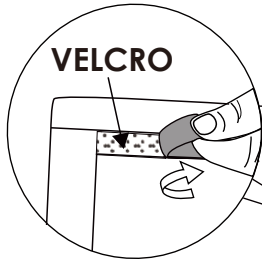

### Assembly Option ①

#### STEP 36

If there is a slight bulge when you lift the F2 and then put it down for the first time, it is recommended that you adjust the position of the F2 or press it from both sides.

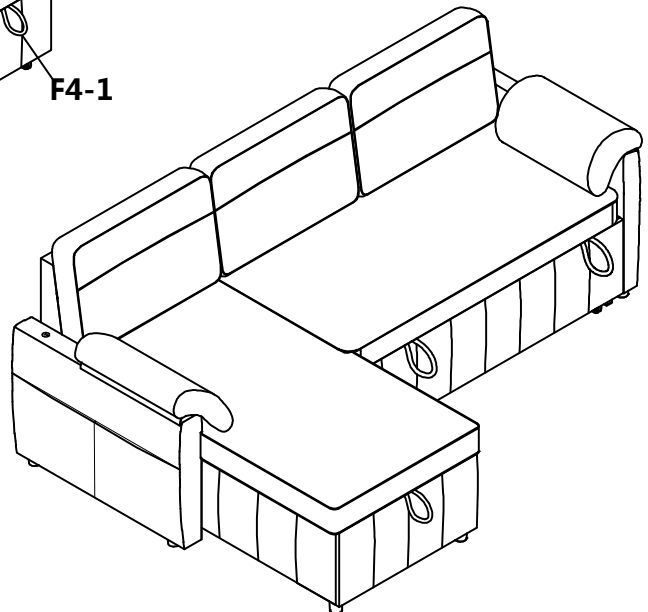
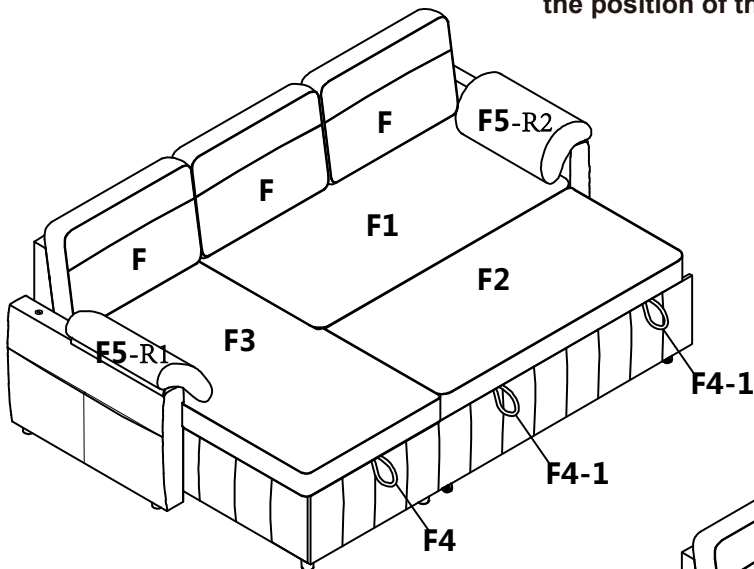

## Assembly Steps(EN)

### Assembly Option ② STEP 28

Please lift the board to easily connect the metal clip.

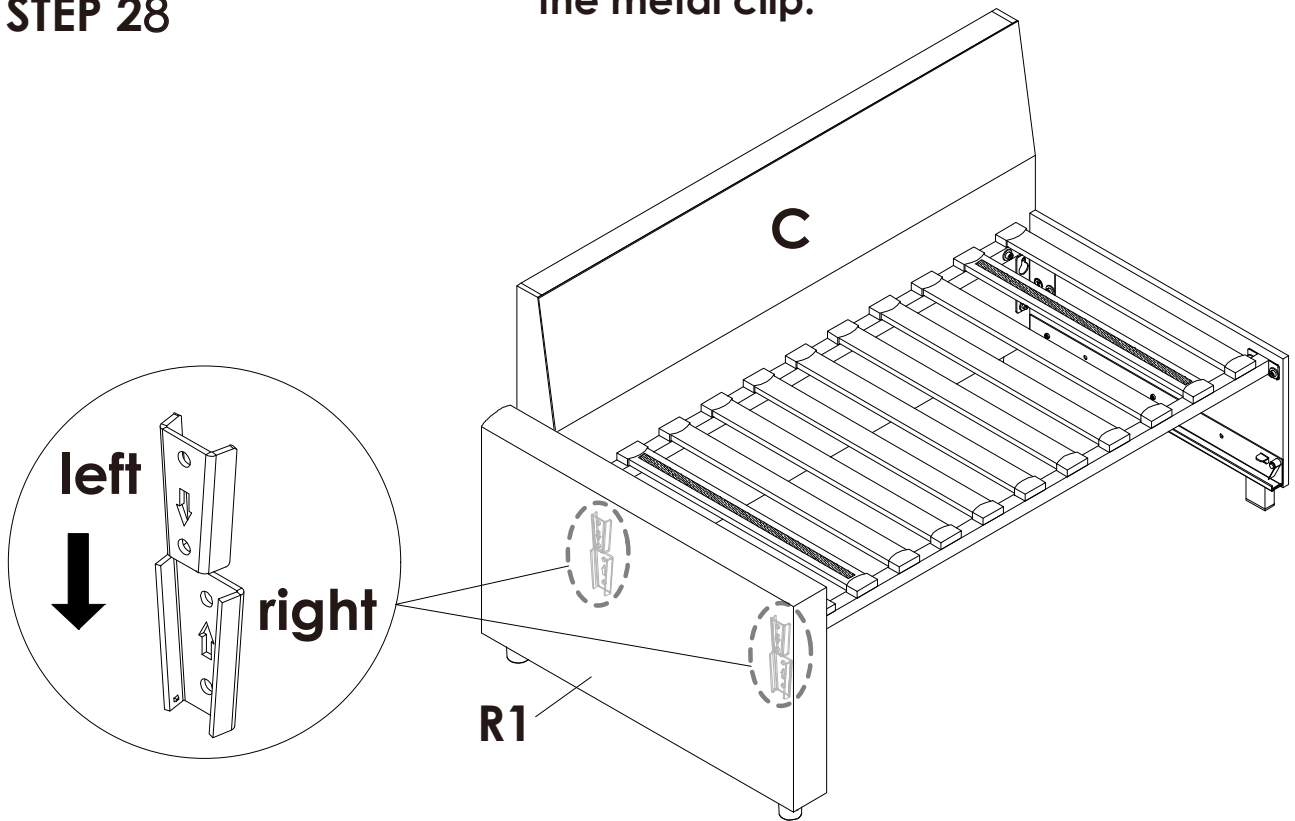

### Assembly Option ② STEP 29

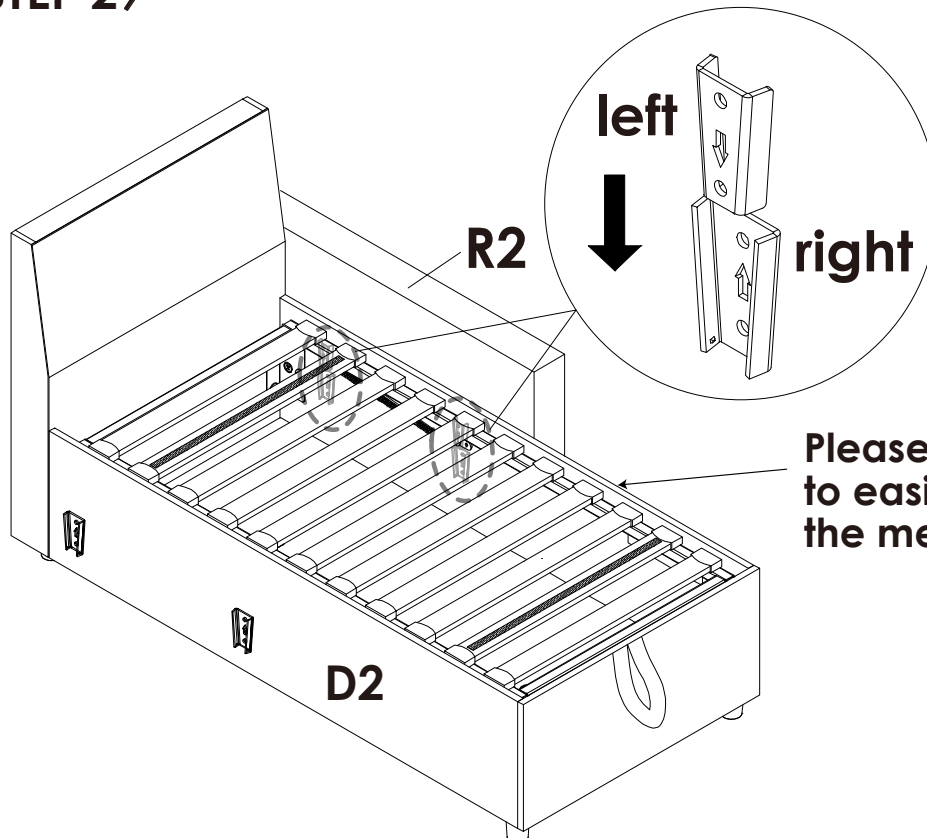

Please lift the board to easily connect the metal clip.

## Assembly Steps(EN)

### Assembly Option ②

#### STEP 30

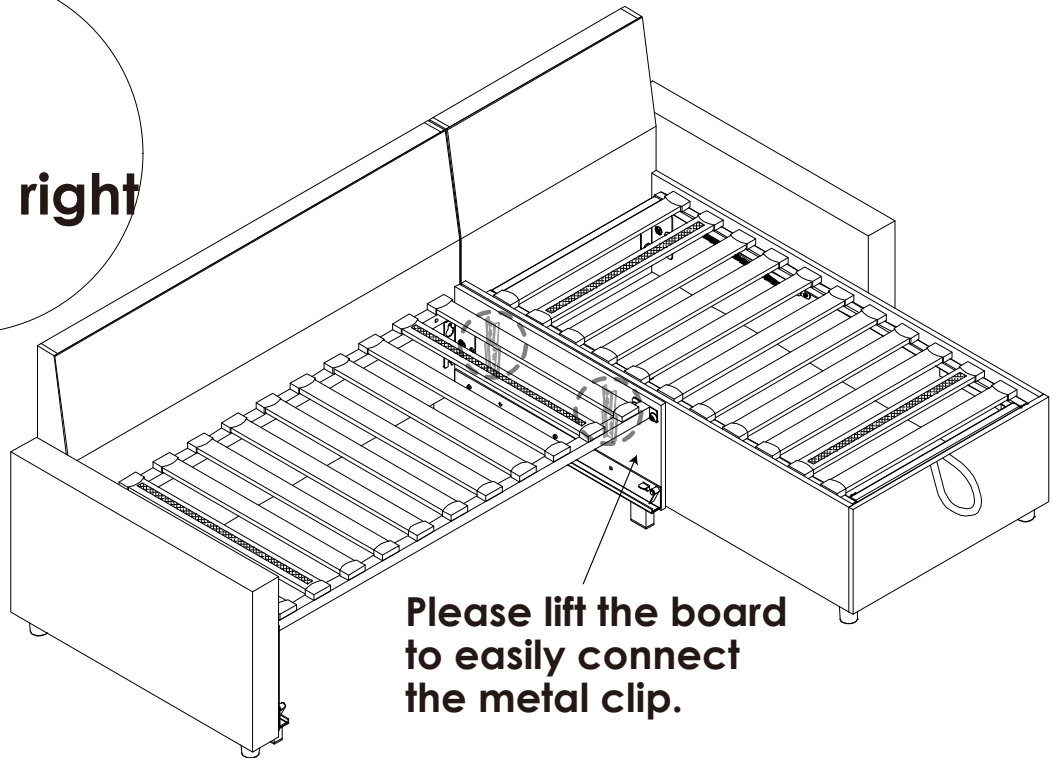
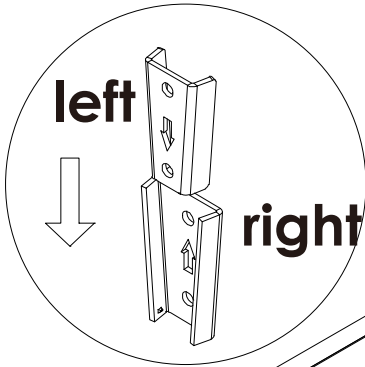

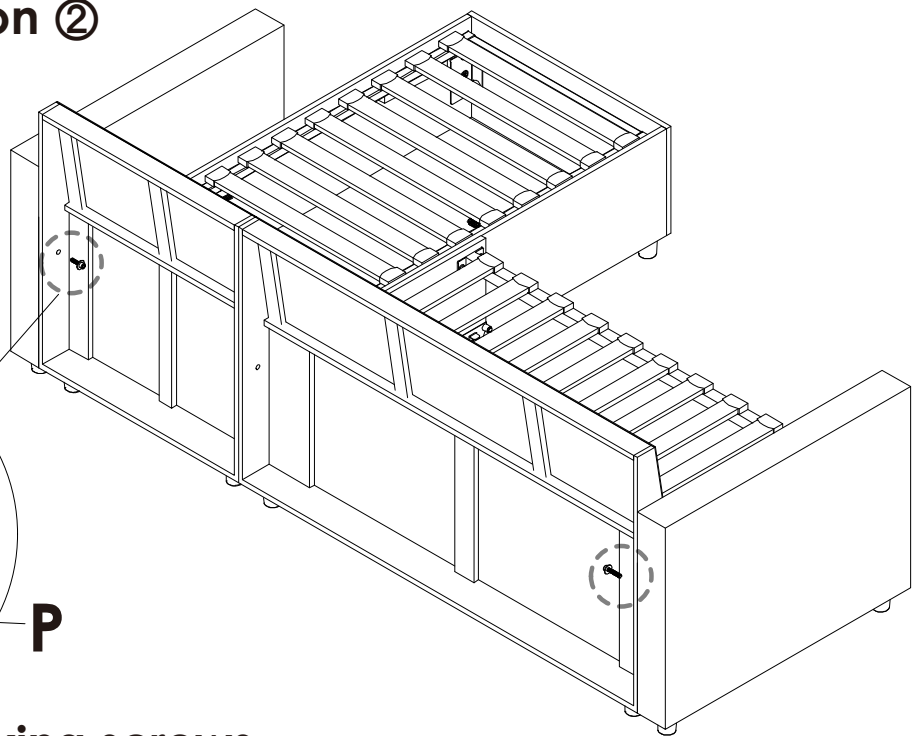
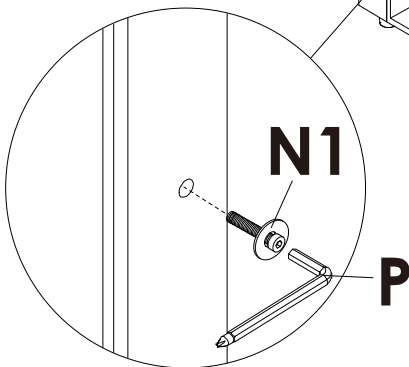

### Assembly Option ②

#### STEP 31



Secure with locking screws

	N1 x 2PCS
	P x 1PC

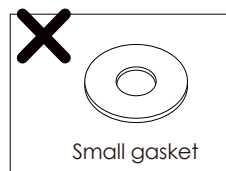

Small gasket

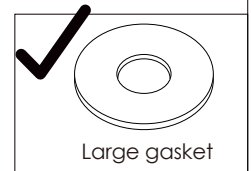

Large gasket



# Assembly Steps(EN)

## Assembly Option ②

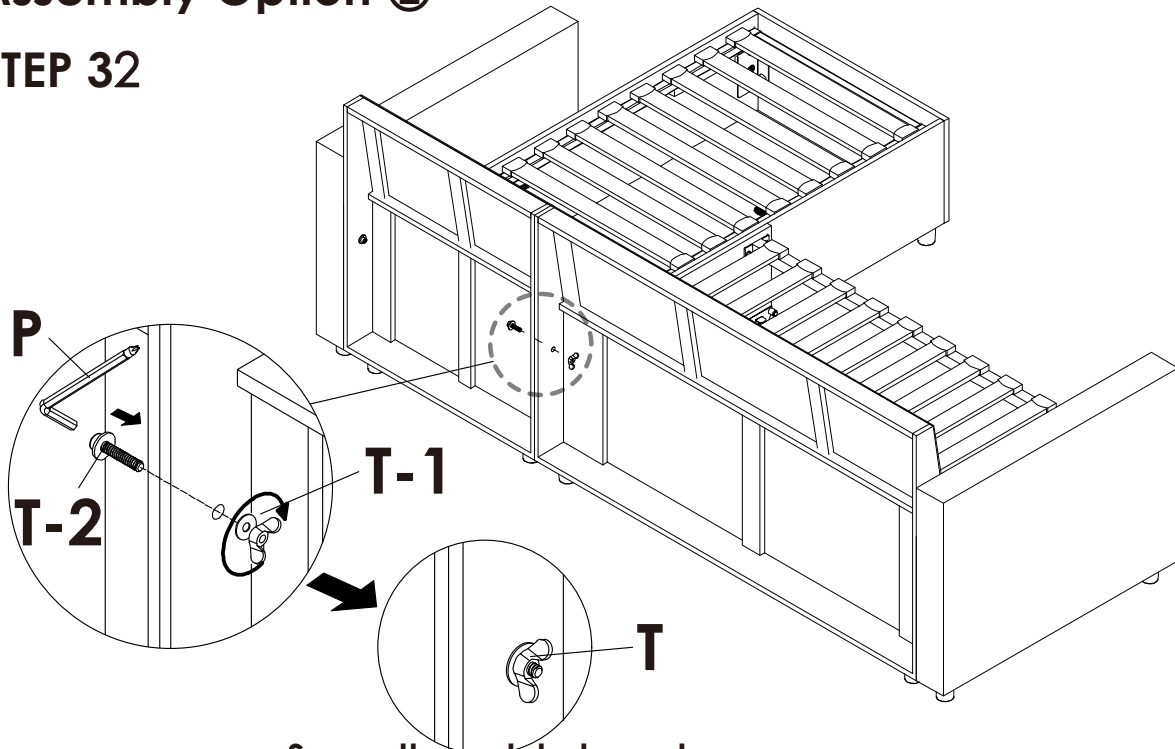
### STEP 32



Screw through hole and tighten with butterfly nut.

	P x 1PC
	T x 1PC

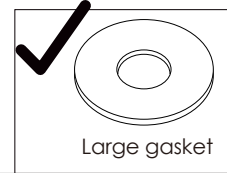
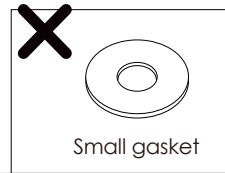

## Assembly Option ②

### STEP 33

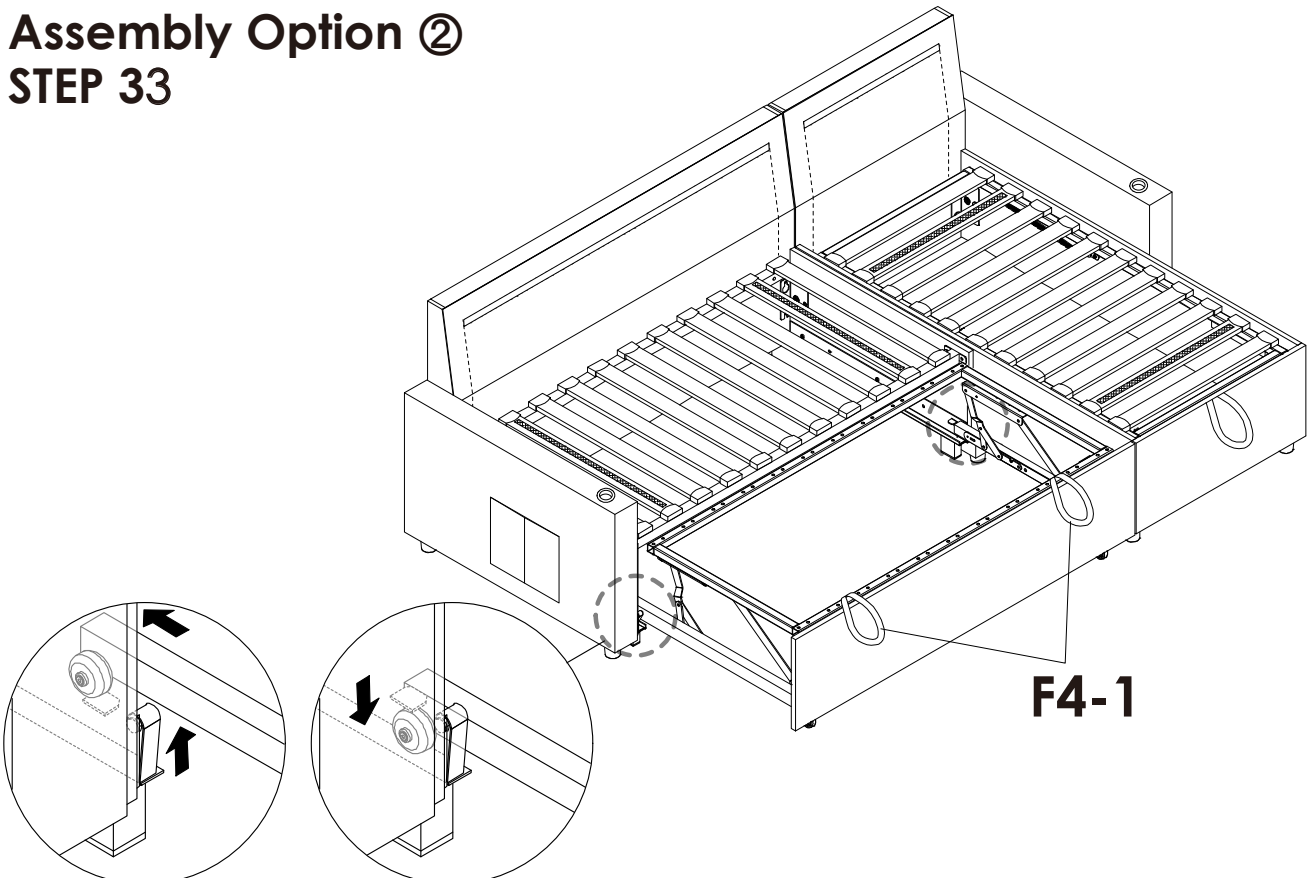

Life it slightly and place it on the track.

## Assembly Steps(EN)

### Assembly Option ②

#### STEP 34

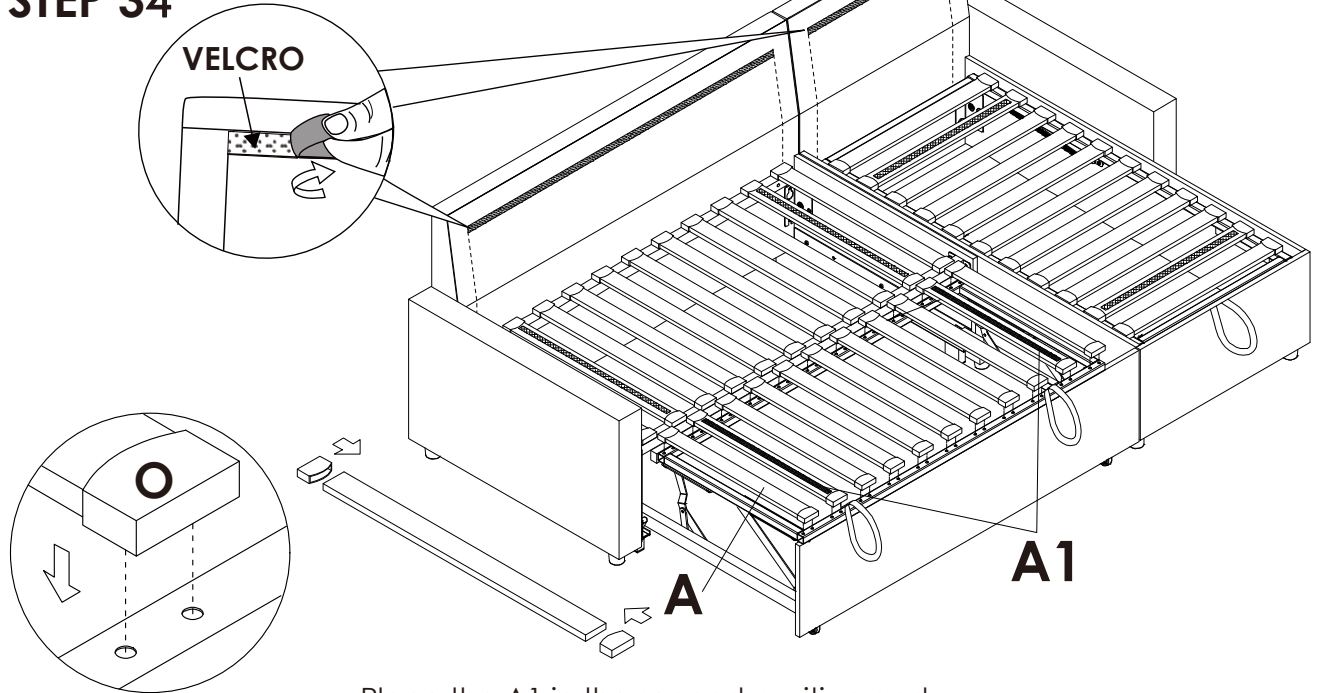

Place the A1 in the second position and note that the Nylon Fastener side is facing up.



○ x 22PCS

### Assembly Option ②

#### STEP 35

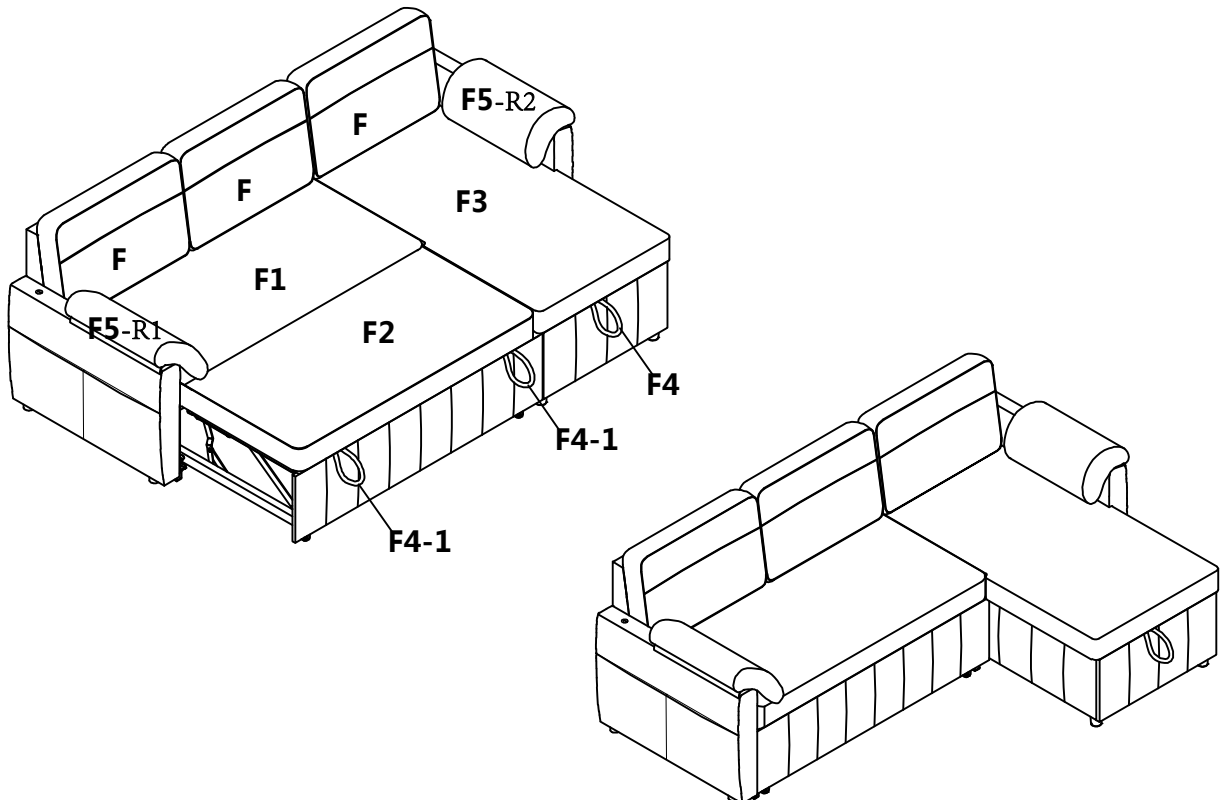

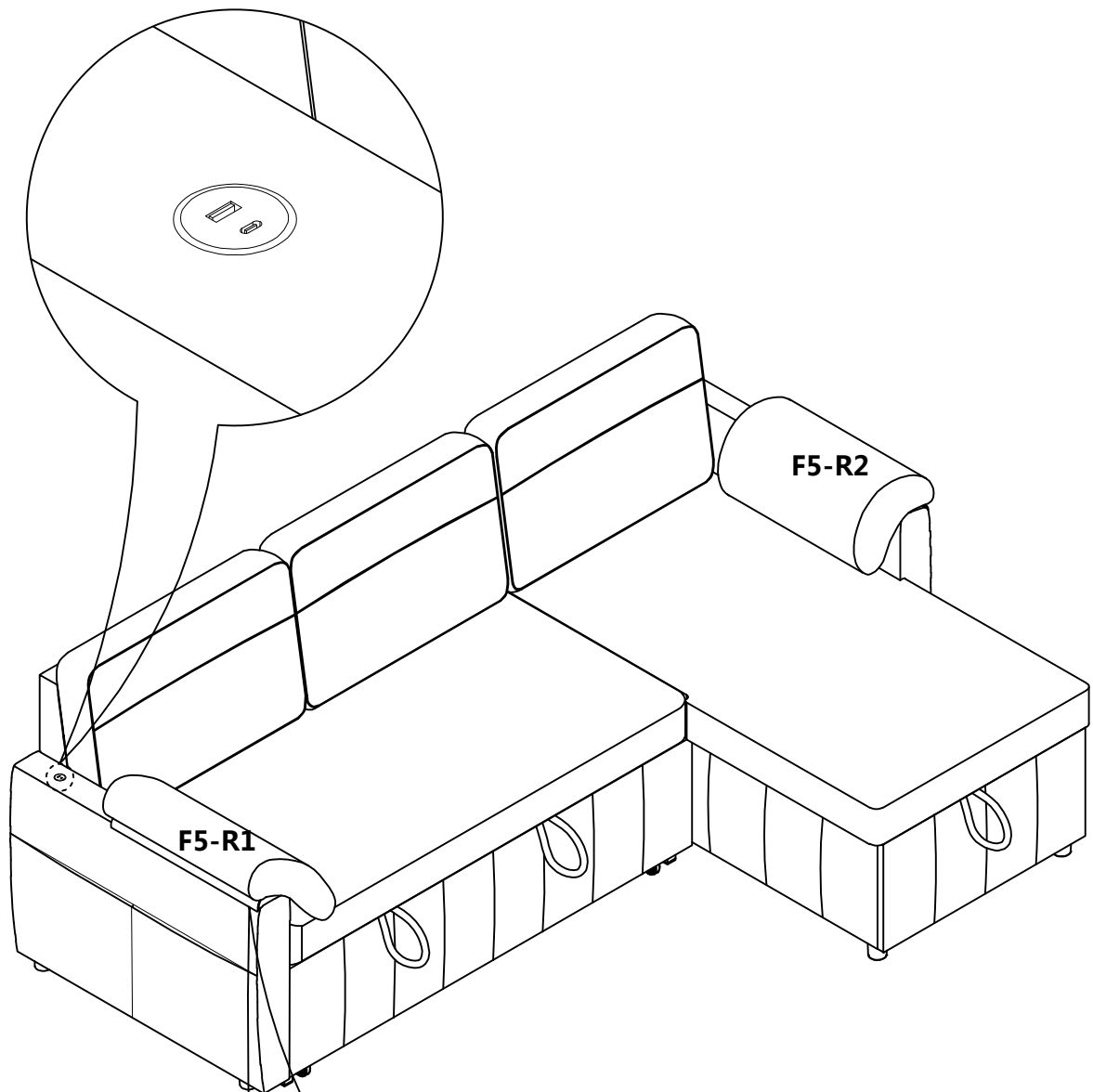

Insert the zipper head and tighten the zipper

