

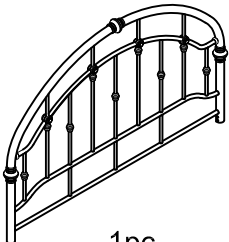

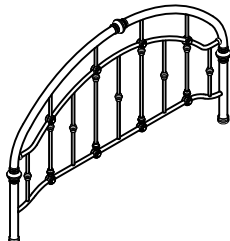







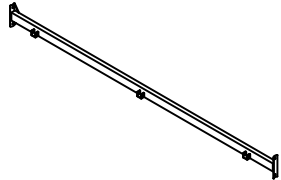
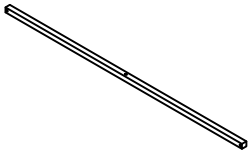
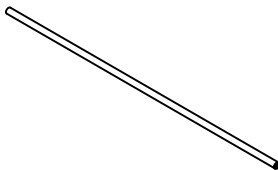

ASSEMBLY INSTRUCTION

ROUND TOP SHAPE FULL SIZE BED

A Headboard  1pc	B Footboard  1pc	C Extension Leg  2pcs	D Side rail  2pcs
E Slats  3pcs	F Cross bar  2pcs	G Support Leg  3pcs	H Bolt 1/4", 13mm  4pcs
I Bolt 1/4", 22mm  4pcs	J Bolt 1/4", 44mm  9pcs	K Bolt 1/4", 57mm  8pcs	L Flat Washer  23pcs
M Nut  10pcs	N Allen Wrench  1pc	O Wrench  1pc	

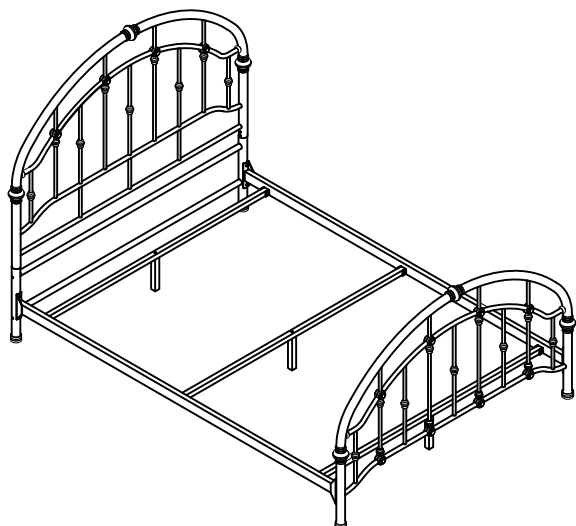

This page lists all the contents included in the box. Please take the time to identify the hardware as well as the individual components to this product. As you unpack and prepare for assembly, place the contents on a carpeted or padded area to protect them from damage.

1

Assemble the cross bar (F) to the extension leg (C) with 4 bolt (K) and fastened using allen wrench (N).

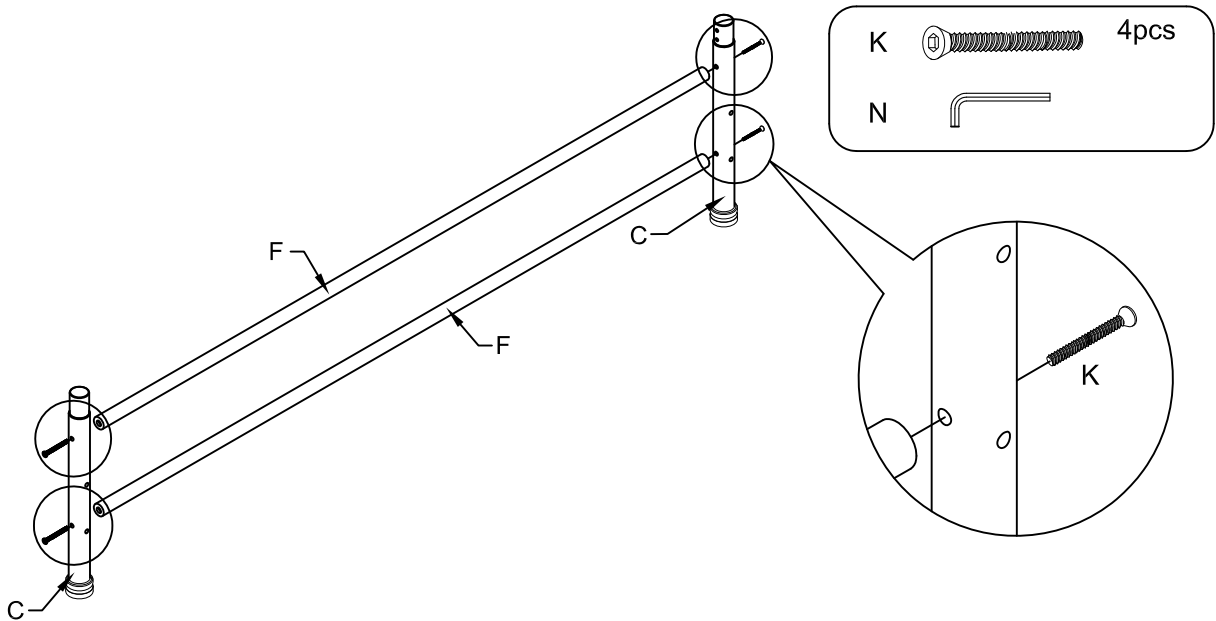

2

Assemble the headboard (A) to the extension leg (C) with 4 bolt (H) and fastened using allen wrench (N).

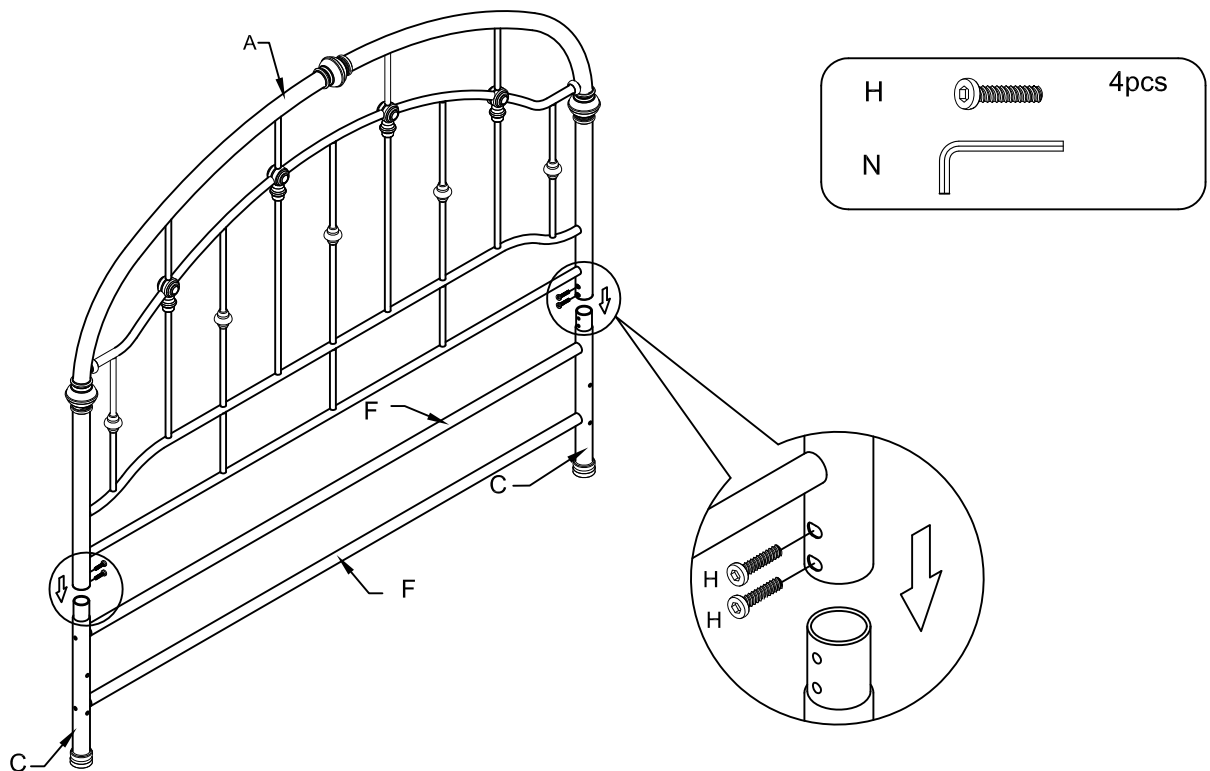

3

Attach side rail (D) to the headboard (A) and assemble each end with 2 bolt (K), 2 flat washer (L), 2 nut (M) then fastened using wrench (O) but do not tighten them completely until the footboard is also assemble. Next, attach footboard (B) to the other ends of side rail (D) and assemble each with 2 bolt (I), 2 flat washer (L), then fastened using allen wrench (N) now, tighten all the bolts and nuts completely.

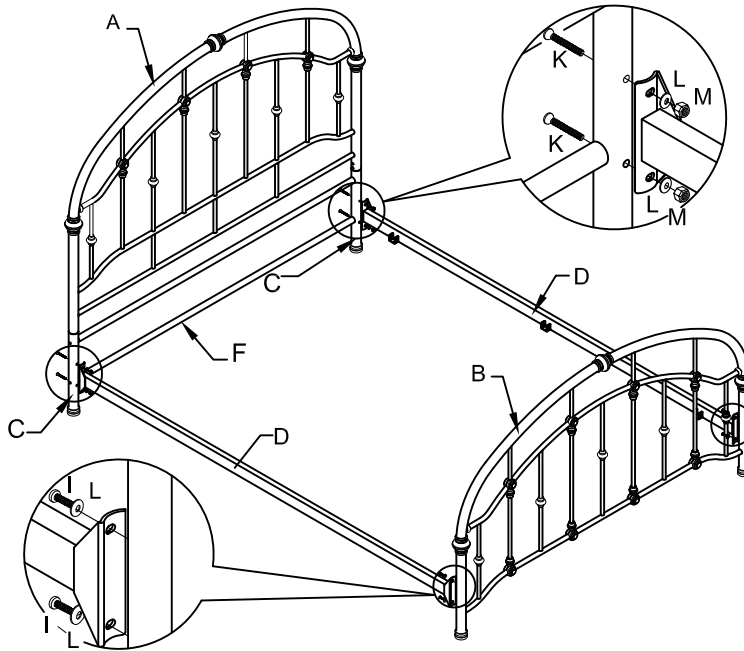

K		4pcs
I		4pcs
L		8pcs
M		4pcs
N		
O		

4

Assemble the support leg (G) to the slat (E) with 1 flat washer (L) and 1 bolt (J) for each the support leg, then fastened using allen wrench (N).

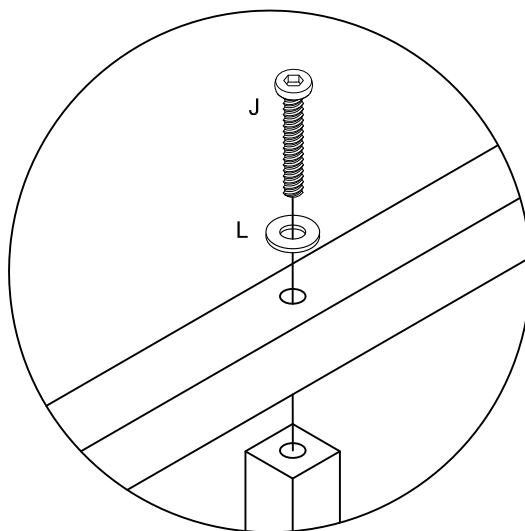

J		3pcs
L		3pcs
N		

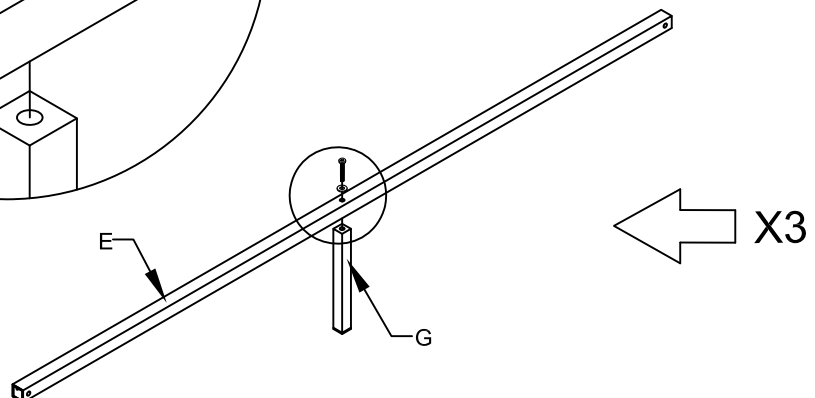

5

Assemble the slat E to the side rail (D) with 2 flat washer(L), 1 nut (M) and 1 bolt (J) for two ends of each slat, then fastened using allen wrench (N) and wrench (O).

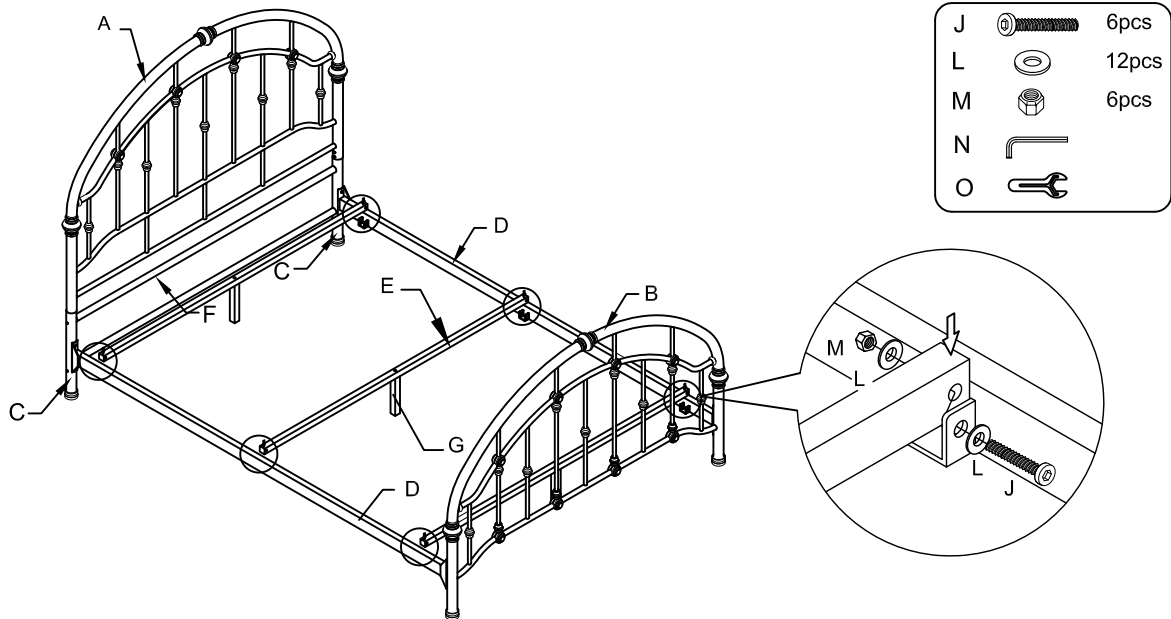
**6**

Assemble completed as below drawing.

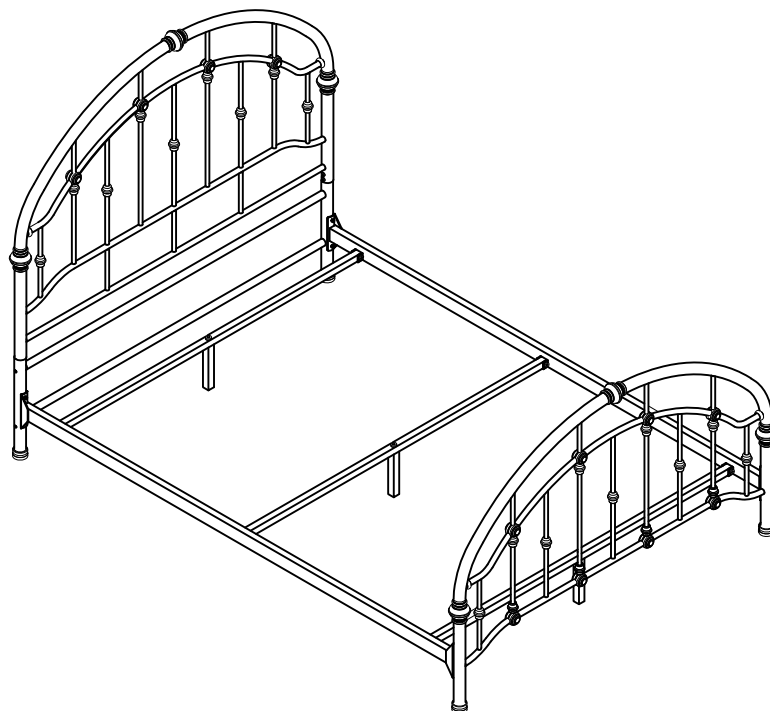

Cleaning & Care

Treat surface with care. Surface is resistant to scratches but is not scratch resistant. Clean surfaces with a dry or damp soft cloth. Do not use abrasive cleaners. Hardware may loosen over time. Periodically check that all connections are tight.