

**ASSEMBLY INSTRUCTIONS**  
**COASTER FINE FURNITURE**

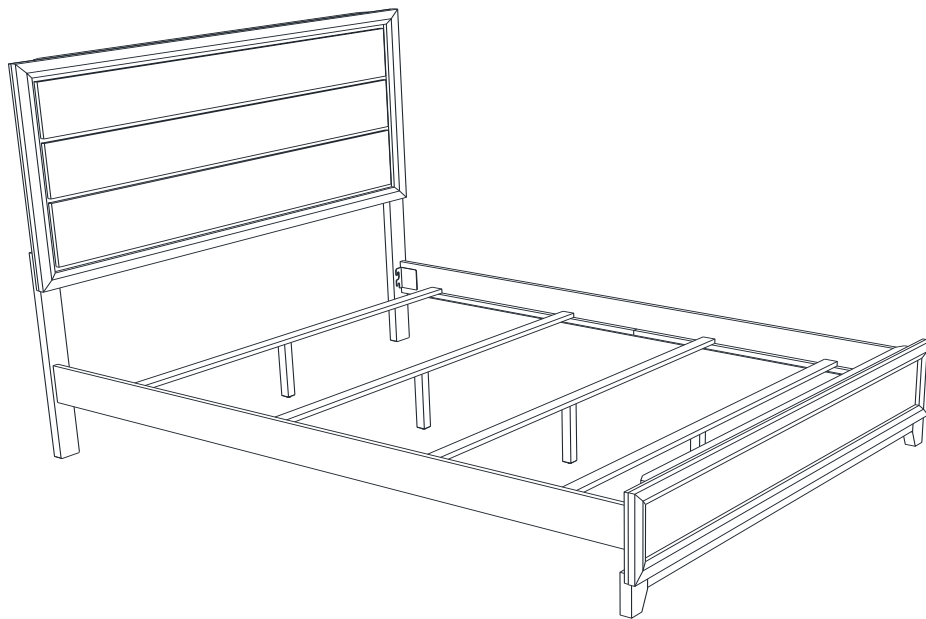

*Fine Furniture for every stage of life*

**212421Q (B1&B2)**  
***Queen Bed***

REVISION 0 : 10/16/2017  
REVISION 1 : 08/09/2018  
REVISION 2 : 08/28/2018  
REVISION 3 : 01/02/2019  
REVISION 4 : 12/13/2019

# ITEM: 212421Q (B1&B2)



## ASSEMBLY INSTRUCTIONS

### ASSEMBLY TIPS:

1. Remove hardware from box and sort by size.
2. Please check to see that all hardware and parts are present prior to start of assembly.
3. Please follow attached instructions in the same sequence as numbered to assure fast & easy assembly.



### WARNING!

1. Don't attempt to repair or modify parts that are broken or defective. Please contact the store immediately.
2. This product is for home use only and not intended for commercial establishments.



ASSEMBLY TIME

20 MINUTES

## PARTS IDENTIFICATION

### B1 ( BOX 1 )

A HEADBOARD PANEL

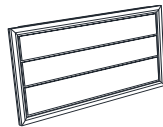

1PC

B FOOTBOARD

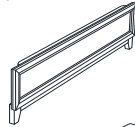

1PC

C RIGHT HEADBOARD LEG

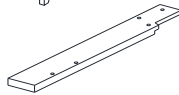

1PC

D LEFT HEADBOARD LEG

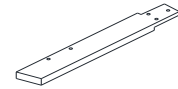

1PC

E BED SLAT

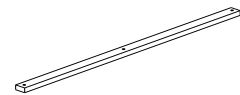

4PCS

F BED SLAT SUPPORT WITH LEVELER

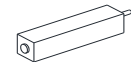

4PCS

### B2 ( BOX 2 )

G BED RAIL



2PCS

HB 212421Q(B1) FROM BOX 1 HEADBOARD COMPLETE



1PC

B 212421Q(B1) FROM BOX 1 FOOTBOARD

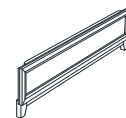

1PC

## HARDWARE IDENTIFICATION

### Z-B1 (BOX 1) - HARDWARE PACK IS LOCATED IN 212421Q (B1)

1 BOLT (M6 x 30mm - BLK)

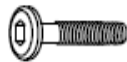

6PCS

2 LOCK WASHER (1/4" - BLK)



6PCS

3 FLAT WASHER (1/4"ID x 13mm - BLK)



6PCS

4 SMALL ALLEN WRENCH (M4 x 60mm - BLK)



1PC

5 BIG ALLEN WRENCH (M5 x 65mm - BLK)



1PC

6 FLAT HEAD SCREW (M4 x 32mm - RBW)



8PCS

### NOTE:

Phillips head screw driver is required in the assembly process; however, manufacturer does not provide this item.

# ITEM: 212421Q (B1&B2)



## ASSEMBLY INSTRUCTIONS

### STEP 1

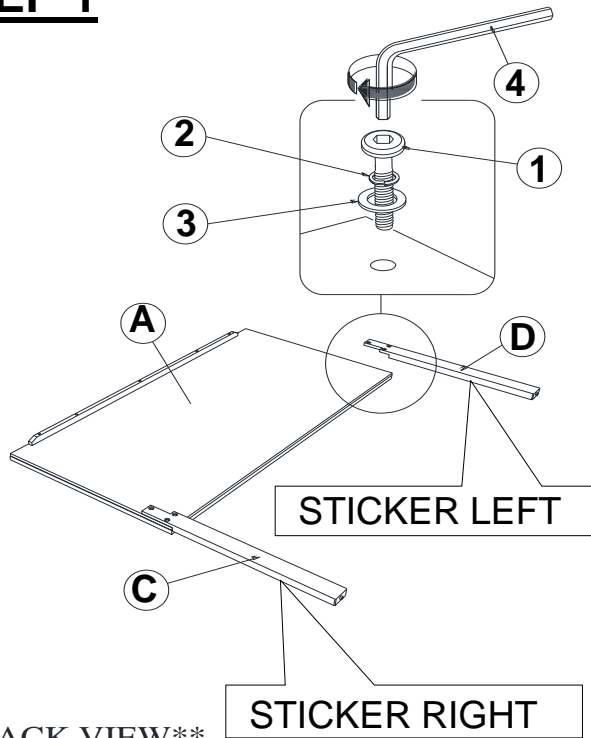

\*\*BACK VIEW\*\*

Note: Please take note of the marking sticker ( L & R ) on the headboard legs.

### STEP 2

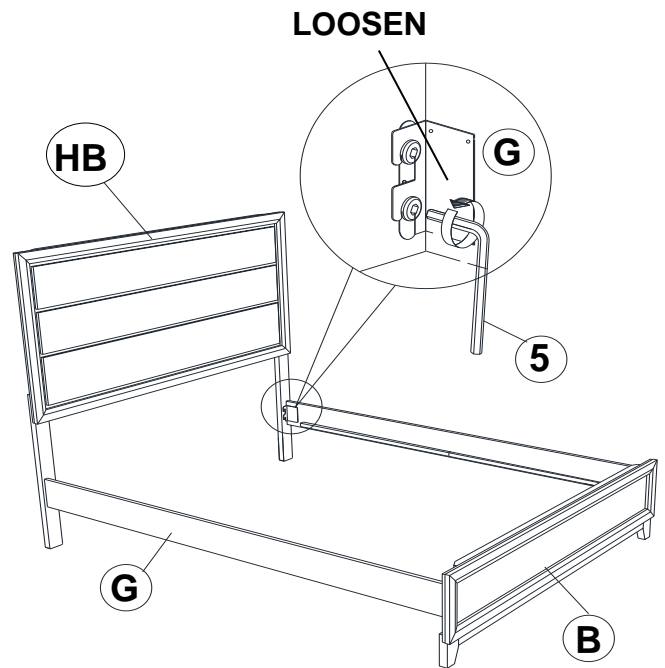

### STEP 3

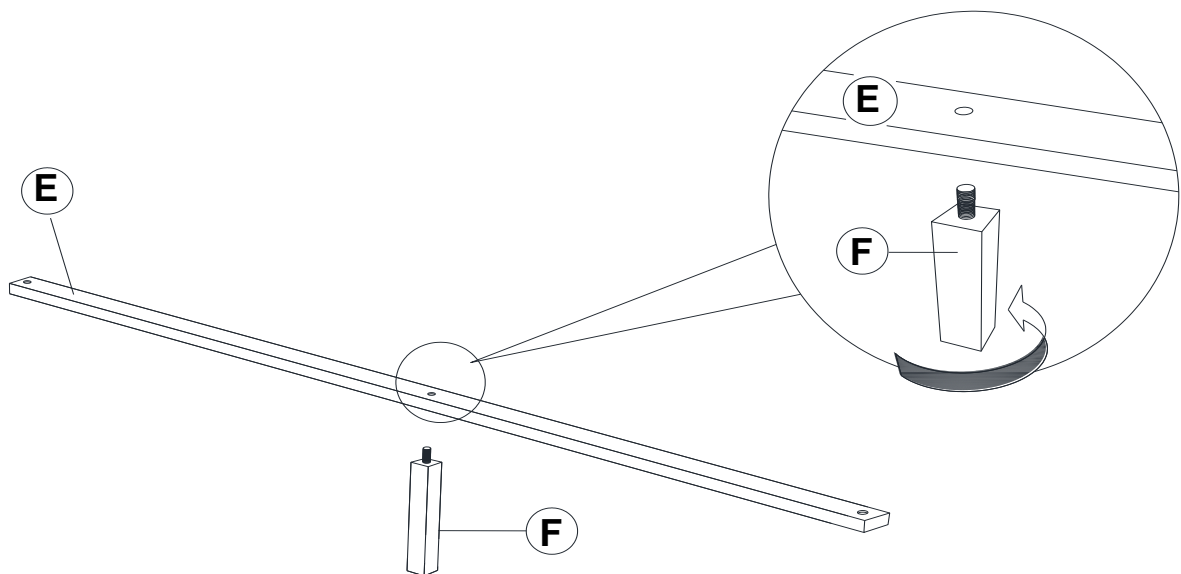

# ITEM: 212421Q (B1&B2)



## ASSEMBLY INSTRUCTIONS

### STEP 4

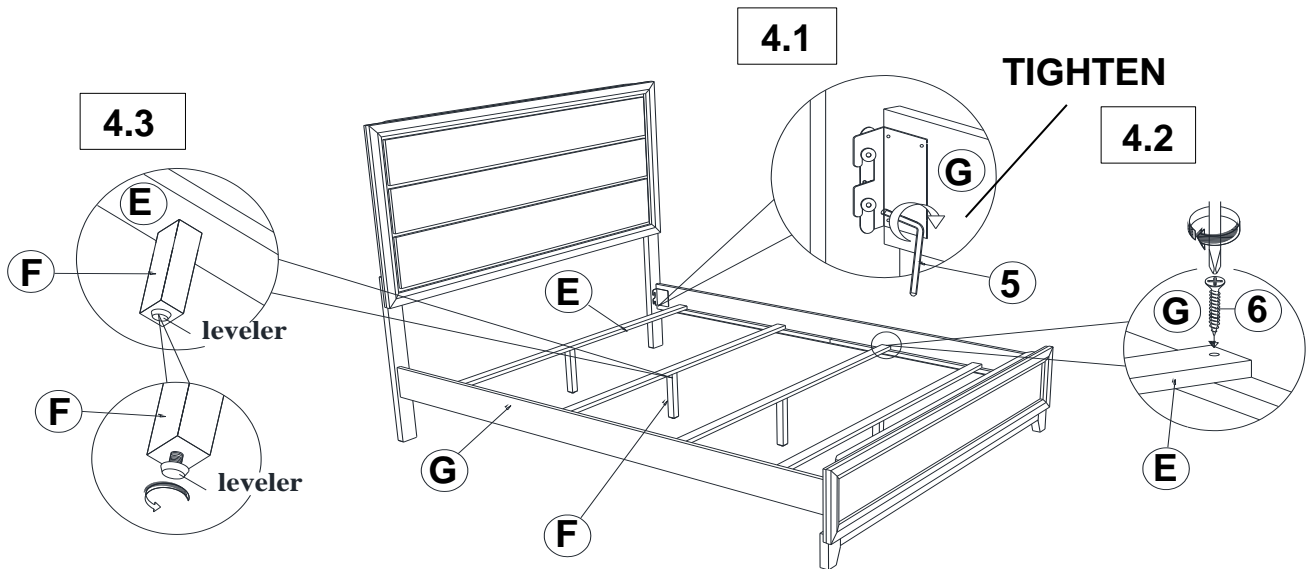

### STEP 5 COMPLETE

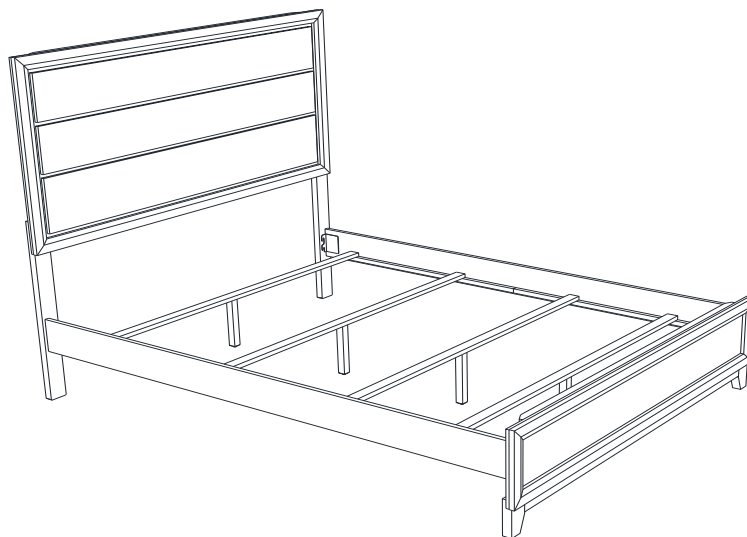

# ITEM: 212421Q (B1&B2)



Inner Size : 60.75"W X 81.00"D

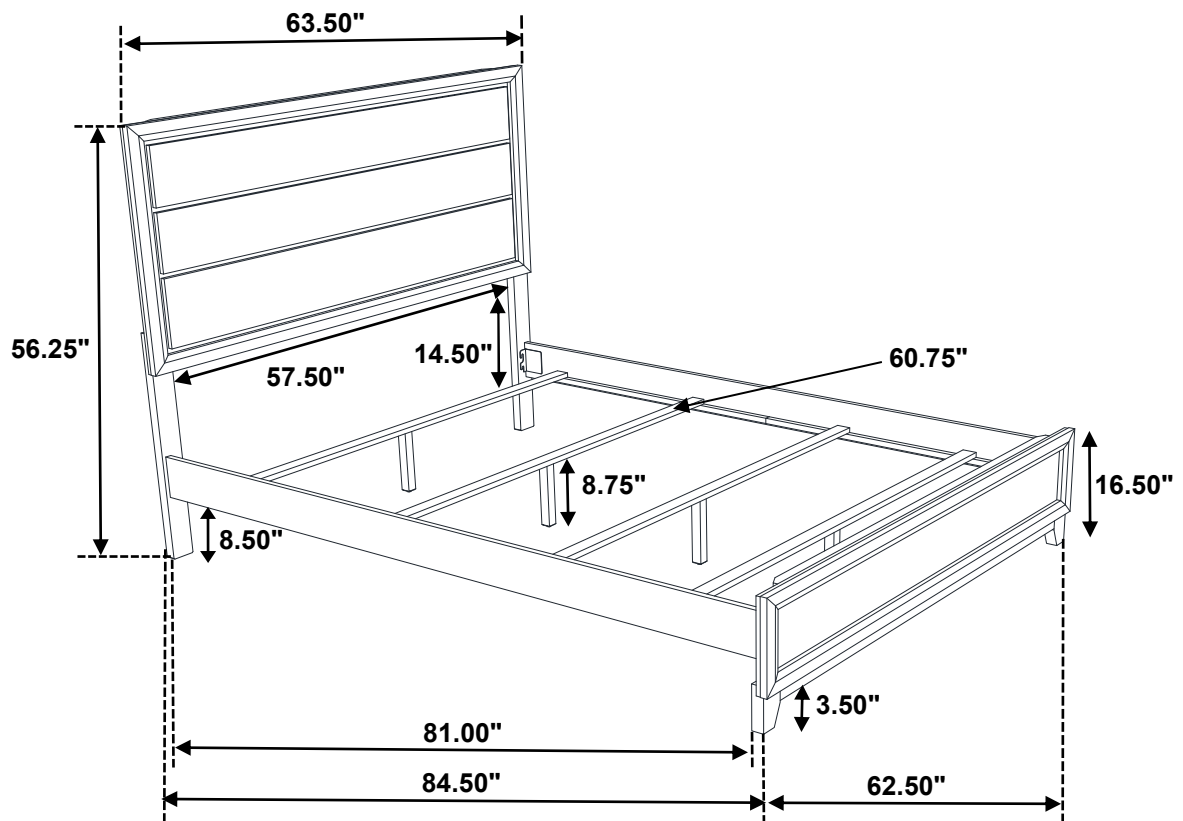

Note : Dimension tolerance  $\pm 5\%$

*ASSEMBLY INSTRUCTIONS*  
*COASTER FINE FURNITURE*



*Fine Furniture for every stage of life*

**212422**  
***Nightstand***

REVISION 0 : 10/16/2017  
REVISION 1 : 12/26/2017  
REVISION 2 : 08/09/2018  
REVISION 3 : 01/02/2019  
REVISION 4 : 12/13/2019

ITEM: **212422**



## ASSEMBLY INSTRUCTIONS

### ASSEMBLY TIPS:

1. Remove hardware from box and sort by size.
2. Please check to see that all hardware and parts are present prior to start of assembly.
3. Please follow attached instructions in the same sequence as numbered to assure fast & easy assembly.



### WARNING!

1. Don't attempt to repair or modify parts that are broken or defective. Please contact the store immediately.
2. This product is for home use only and not intended for commercial establishments.



ASSEMBLY TIME

5 MINUTES

## PARTS IDENTIFICATION

A NIGHTSTAND

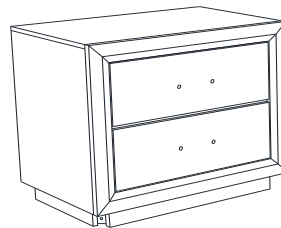

1PC

B LEG



4PCS

## HARDWARE IDENTIFICATION

1 BOLT  
(M6 x 50mm - BLK)

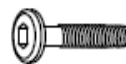

4PCS

2 LOCK WASHER  
(1/4" - BLK)



4PCS

3 FLAT WASHER  
(1/4" ID x 19mm - BLK)



4PCS

4 ALLEN WRENCH  
(M4 x 60mm - BLK)



1PC

### NOTE:

Phillips head screw driver is required in the assembly process; however, manufacturer does not provide this item.

ITEM: **212422**

**ASSEMBLY INSTRUCTIONS**

**STEP 1**

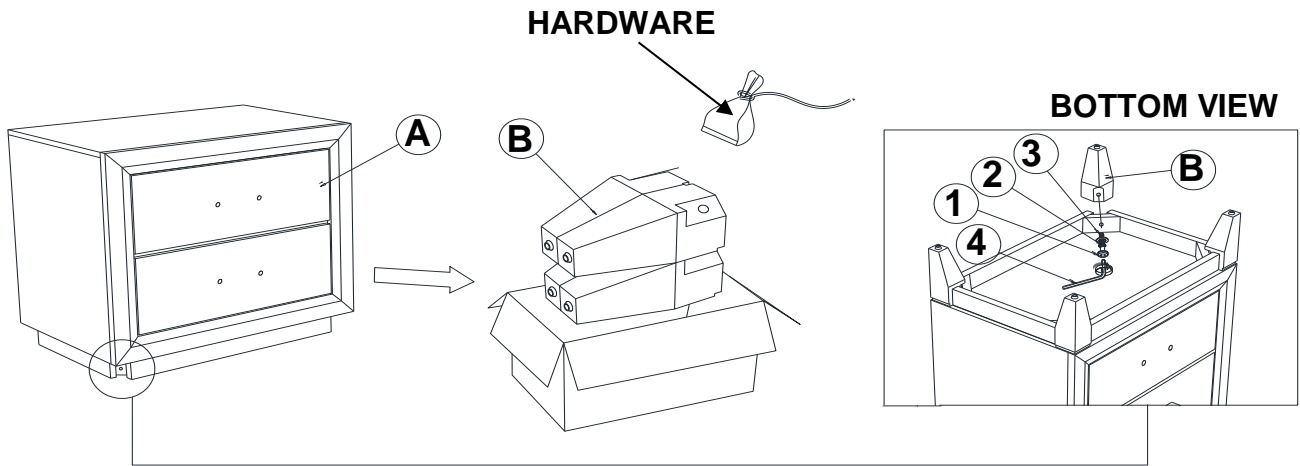

**STEP 2**

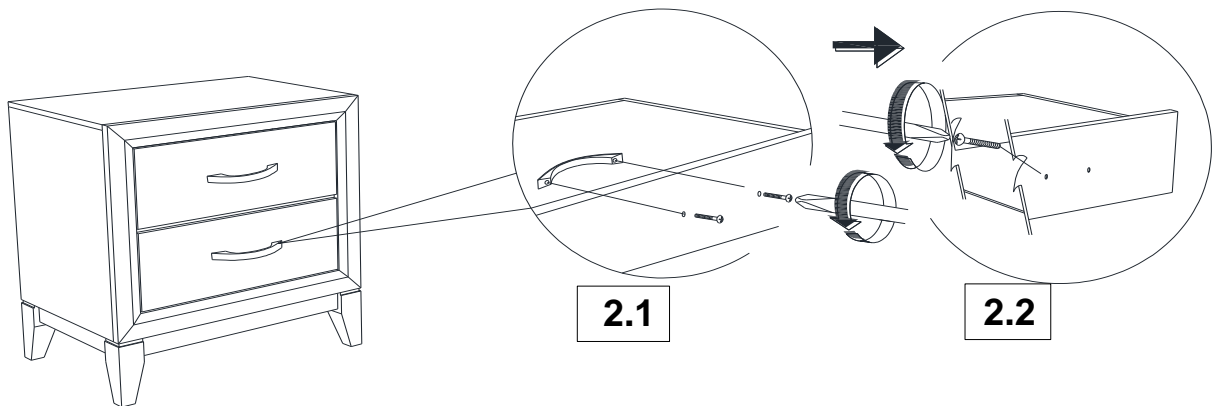

**STEP 3**  
**COMPLETE**

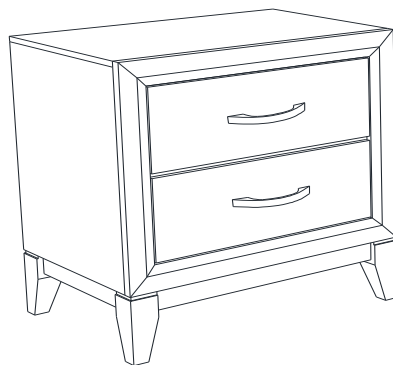

ITEM:212422



Inner Size of Drawer : 17.00"W x 12.50"D x 4.00"H x 0.25"T

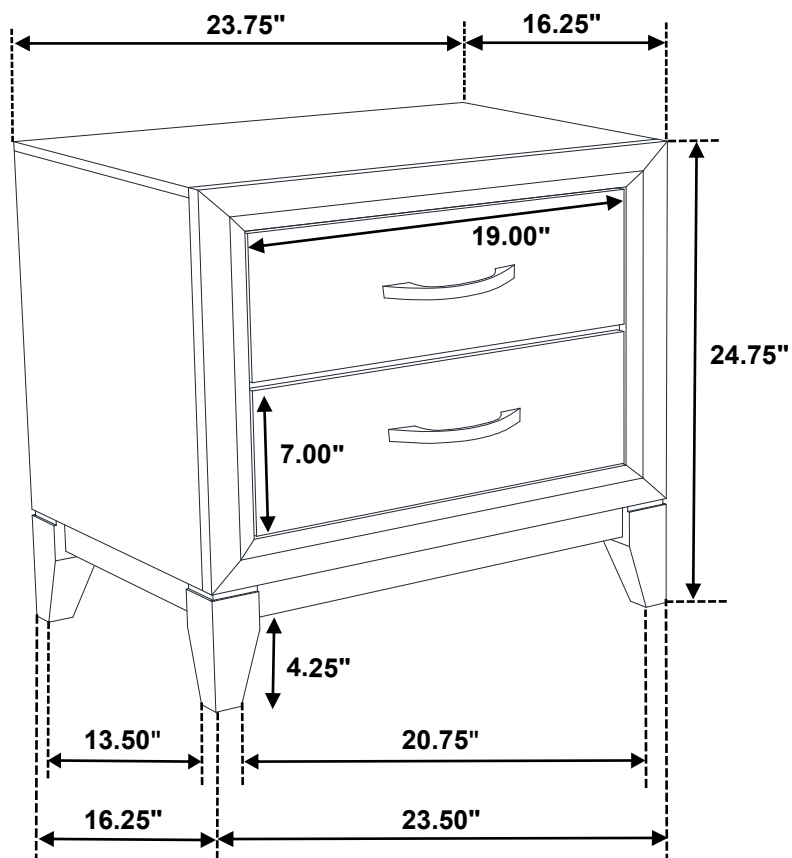

Note : Dimension tolerance  $\pm 5\%$

**ASSEMBLY INSTRUCTIONS**  
**COASTER FINE FURNITURE**



*Fine Furniture for every stage of life*

**212423**  
***Dresser***

REVISION 0 : 10/16/2017  
REVISION 1 : 12/26/2017  
REVISION 2 : 08/09/2018  
REVISION 3 : 01/02/2019  
REVISION 4 : 12/13/2019

ITEM:212423



## ASSEMBLY INSTRUCTIONS

### ASSEMBLY TIPS:

1. Remove hardware from box and sort by size.
2. Please check to see that all hardware and parts are present prior to start of assembly.
3. Please follow attached instructions in the same sequence as numbered to assure fast & easy assembly.



### WARNING!

1. Don't attempt to repair or modify parts that are broken or defective. Please contact the store immediately.
2. This product is for home use only and not intended for commercial establishments.



ASSEMBLY TIME

5 MINUTES

## PARTS IDENTIFICATION

A DRESSER

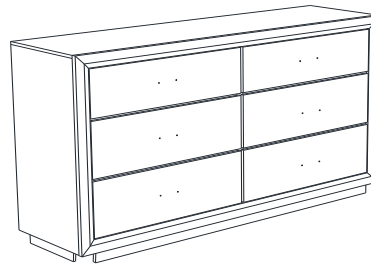

1PC

B LEG



4PCS

C CENTER SUPPORT LEG  
WITH LEVELER



1PC

## HARDWARE IDENTIFICATION

1 BOLT  
(M6 x 50mm - BLK)

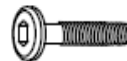

4PCS

2 LOCK WASHER  
(1/4" - BLK)



4PCS

3 FLAT WASHER  
(1/4"ID x 19mm - BLK)



4PCS

4 ALLEN WRENCH  
(M4 x 60mm - BLK)



1PC

### NOTE:

Phillips head screw driver is required in the assembly process; however, manufacturer does not provide this item.

ITEM: 212423

**ASSEMBLY INSTRUCTIONS**

**STEP 1**

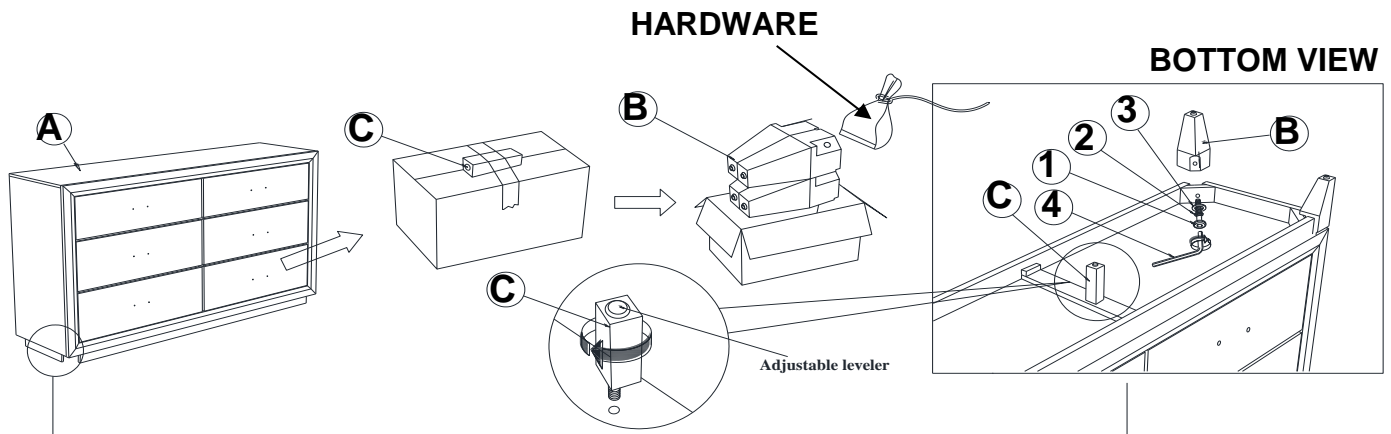

**STEP 2**

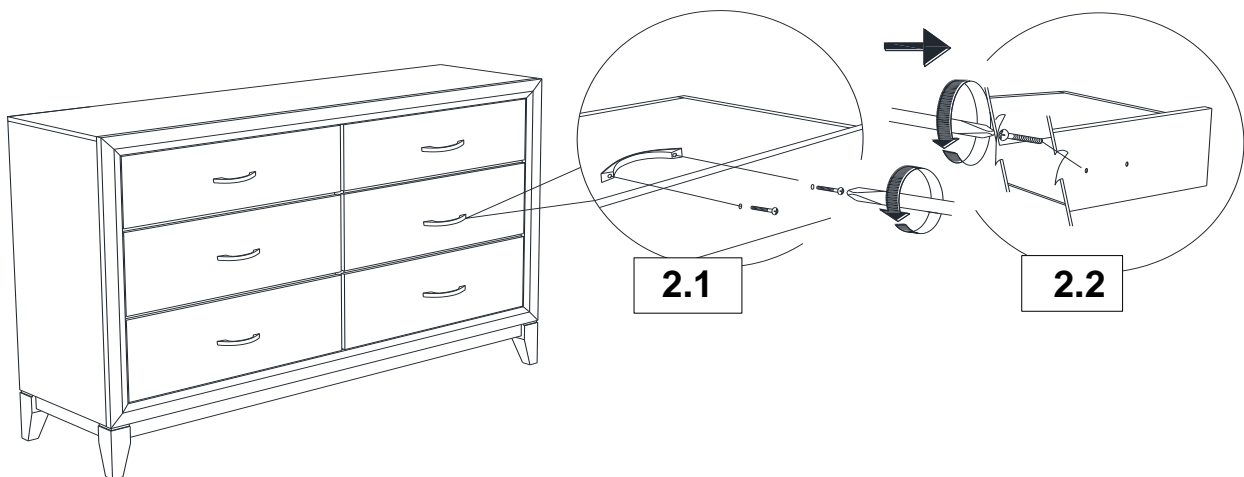

**STEP 3**  
**COMPLETE**



ITEM:212423



Inner Size of Drawer : 23.25"W x 12.50"D x 5.00"H x 0.25"H

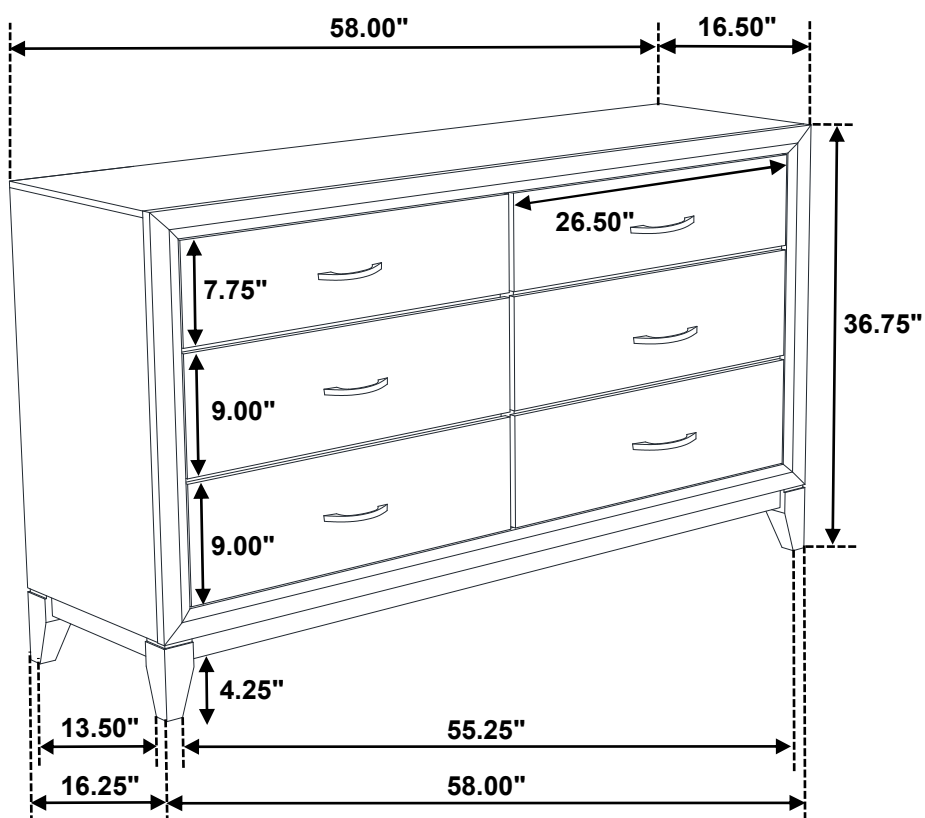

Note : Dimension tolerance  $\pm 5\%$

**ASSEMBLY INSTRUCTIONS**  
**COASTER FINE FURNITURE**



*Fine Furniture for every stage of life*

**212424**  
**Mirror**

REVISION 0 : 10/16/2017  
REVISION 1 : 08/09/2018  
REVISION 2 : 08/29/2018  
REVISION 3 : 01/02/2019  
REVISION 4 : 12/13/2019

# ITEM:212424



## ASSEMBLY INSTRUCTIONS

### ASSEMBLY TIPS:

1. Remove hardware from box and sort by size.
2. Please check to see that all hardware and parts are present prior to start of assembly.
3. Please follow attached instructions in the same sequence as numbered to assure fast & easy assembly.



### WARNING!

1. Don't attempt to repair or modify parts that are broken or defective. Please contact the store immediately.
2. This product is for home use only and not intended for commercial establishments.



ASSEMBLY TIME

10 MINUTES

## PARTS IDENTIFICATION

A MIRROR

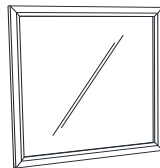

1PC

B DRESSER FROM  
BOX ITEM #212423

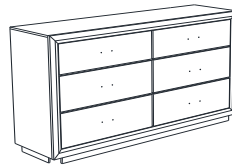

1PC

C MIRROR SUPPORT  
(PACK WITH MIRROR)

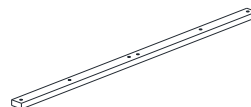

2PCS

## HARDWARE IDENTIFICATION

1 FLAT HEAD SCREW  
(M4 x 32mm - RBW)

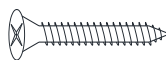

12PCS

### NOTE:

Phillips head screw driver is required in the assembly process; however, manufacturer does not provide this item.

ITEM: **212424**

**ASSEMBLY INSTRUCTIONS**

**STEP 1**

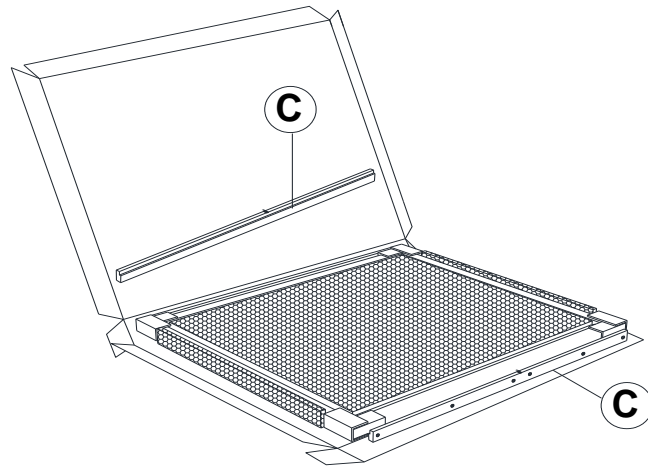

**STEP 2**

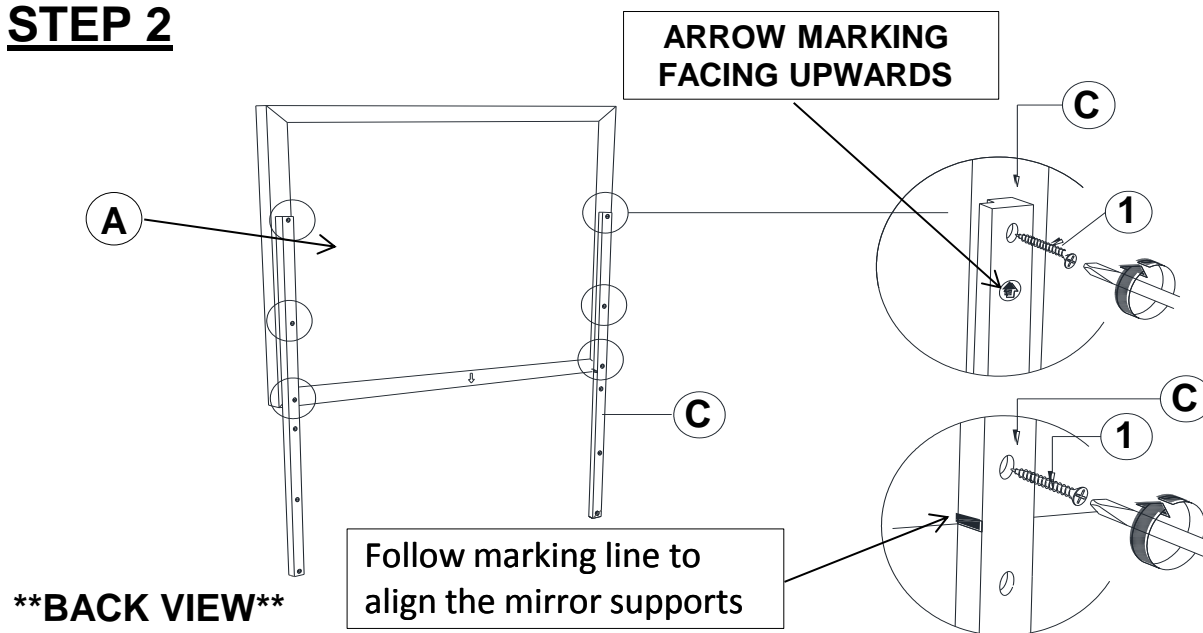

**STEP 3**

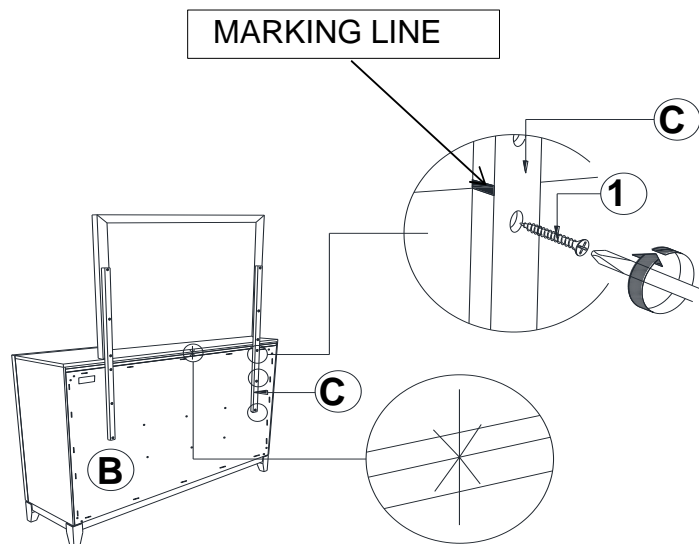

**STEP 4**  
**COMPLETE**

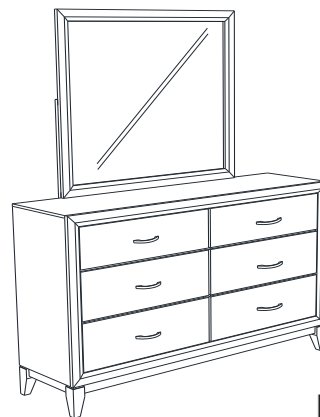

REMARK:  
ARROW MARKING MUST BE ALIGNED



ITEM:212424

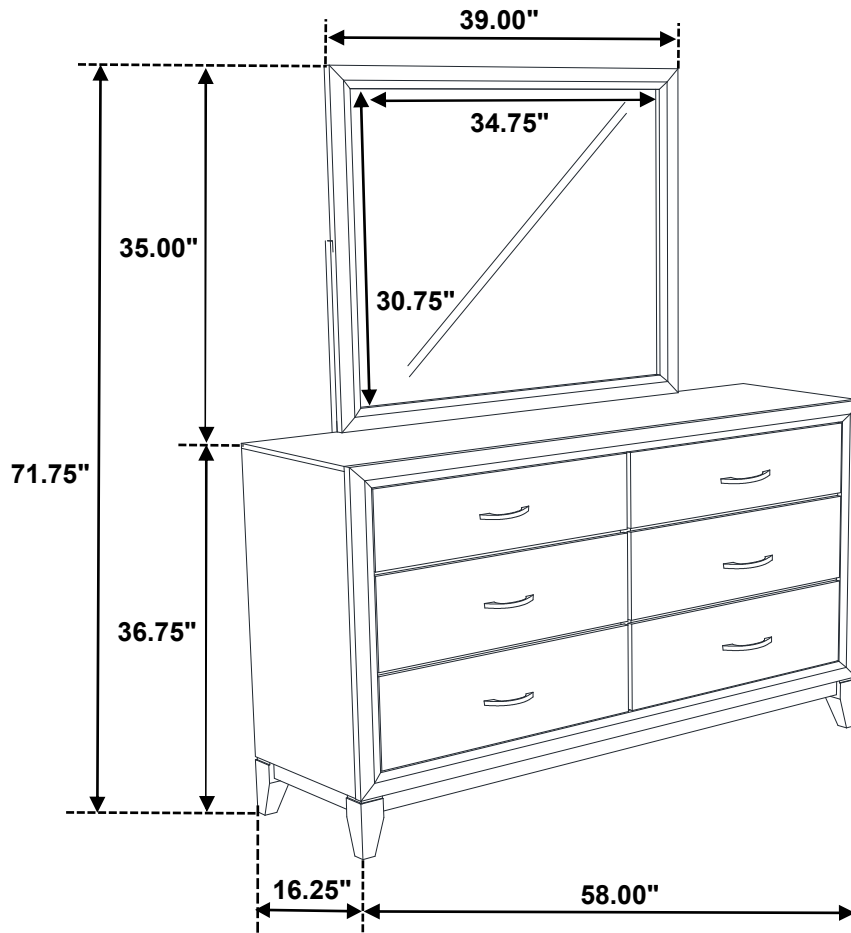

Note : Dimension tolerance  $\pm 5\%$

*ASSEMBLY INSTRUCTIONS*  
*COASTER FINE FURNITURE*



*Fine Furniture for every stage of life*

**212425**  
***Chest***

REVISION 0 : 10/16/2017  
REVISION 1 : 12/26/2017  
REVISION 2 : 08/09/2018  
REVISION 3 : 01/02/2019  
REVISION 4 : 12/13/2019

# ITEM:212425



## ASSEMBLY INSTRUCTIONS

### ASSEMBLY TIPS:

1. Remove hardware from box and sort by size.
2. Please check to see that all hardware and parts are present prior to start of assembly.
3. Please follow attached instructions in the same sequence as numbered to assure fast & easy assembly.



### WARNING!

1. Don't attempt to repair or modify parts that are broken or defective. Please contact the store immediately.
2. This product is for home use only and not intended for commercial establishments.



**ASSEMBLY TIME**

**5 MINUTES**

## PARTS IDENTIFICATION

A

CHEST



1PC

B

LEG



4PCS

## HARDWARE IDENTIFICATION

1

**BOLT**  
(M6 x 50mm - BLK)



4PCS

2

**LOCK WASHER**  
(1/4" - BLK)



4PCS

3

**FLAT WASHER**  
(1/4"ID x 19mm - BLK)



4PCS

4

**ALLEN WRENCH**  
(M4 x 60mm - BLK)



1PC

### NOTE:

Phillips head screw driver is required in the assembly process; however, manufacturer does not provide this item.

ITEM:212425

**ASSEMBLY INSTRUCTIONS**

**STEP 1**

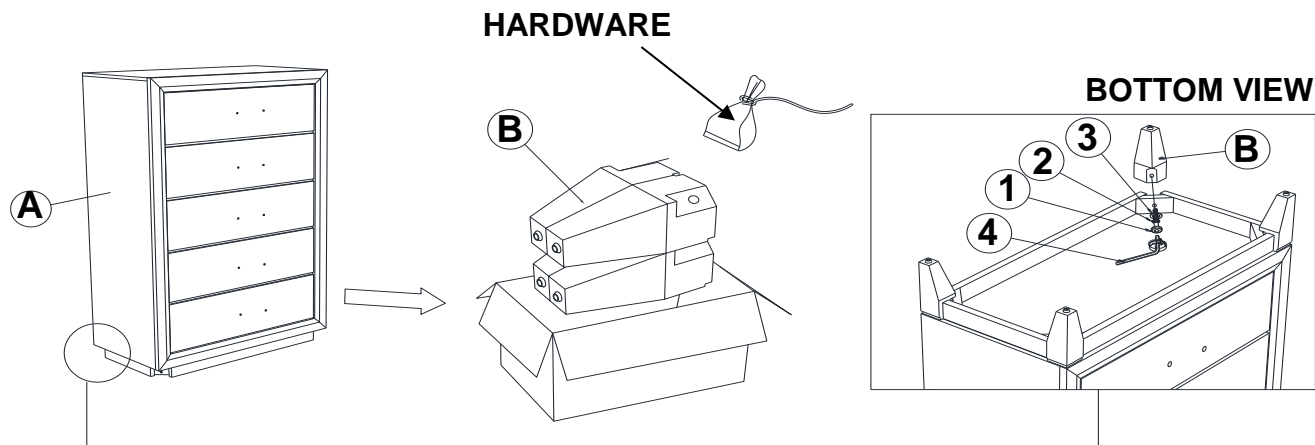

**STEP 2**

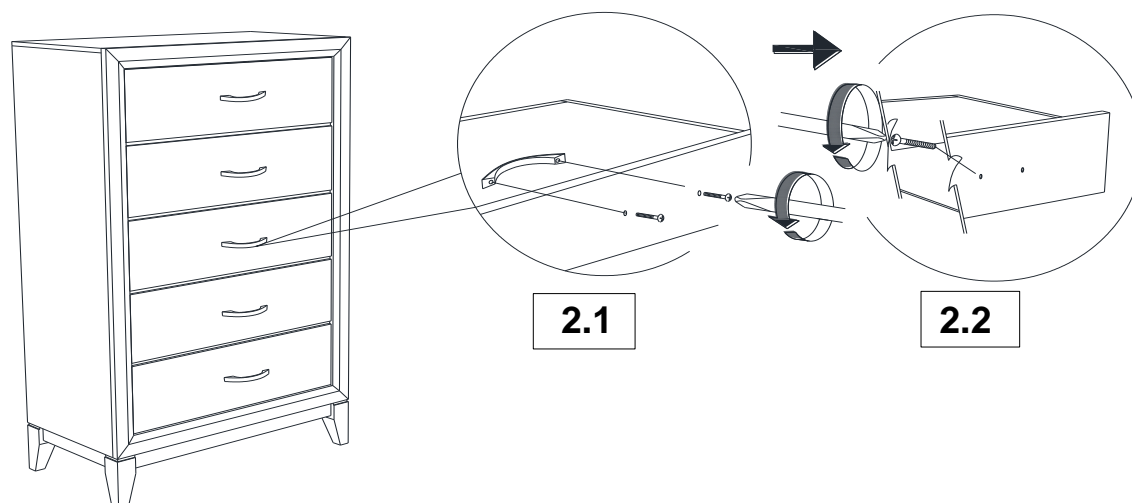

**STEP 3**  
**COMPLETE**



ITEM:212425



Inner Size of Drawer : 23.25"W x 12.50"D x 5.00"H x 0.25"T

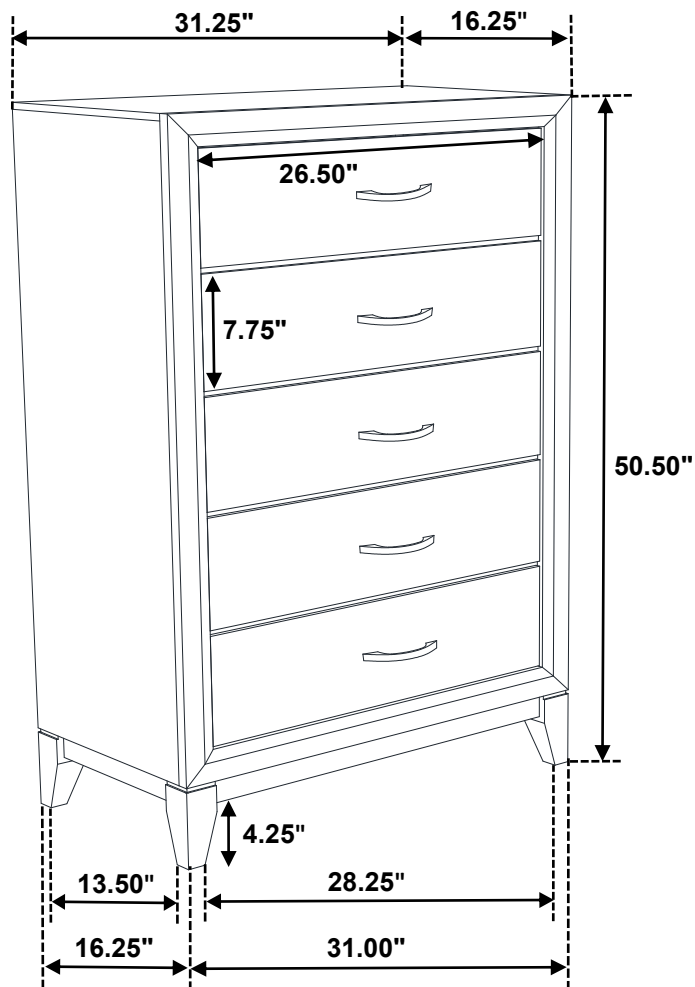

Note : Dimension tolerance  $\pm 5\%$