

# ASSEMBLY INSTRUCTION

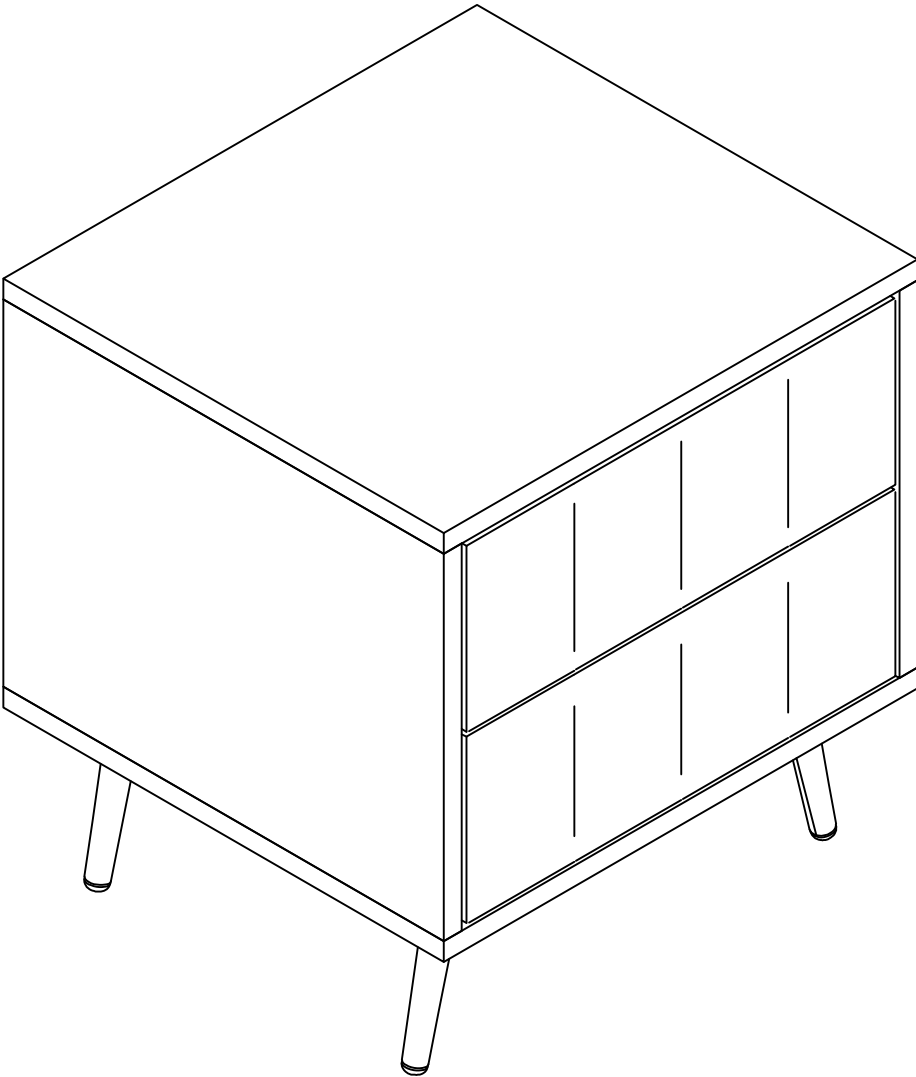

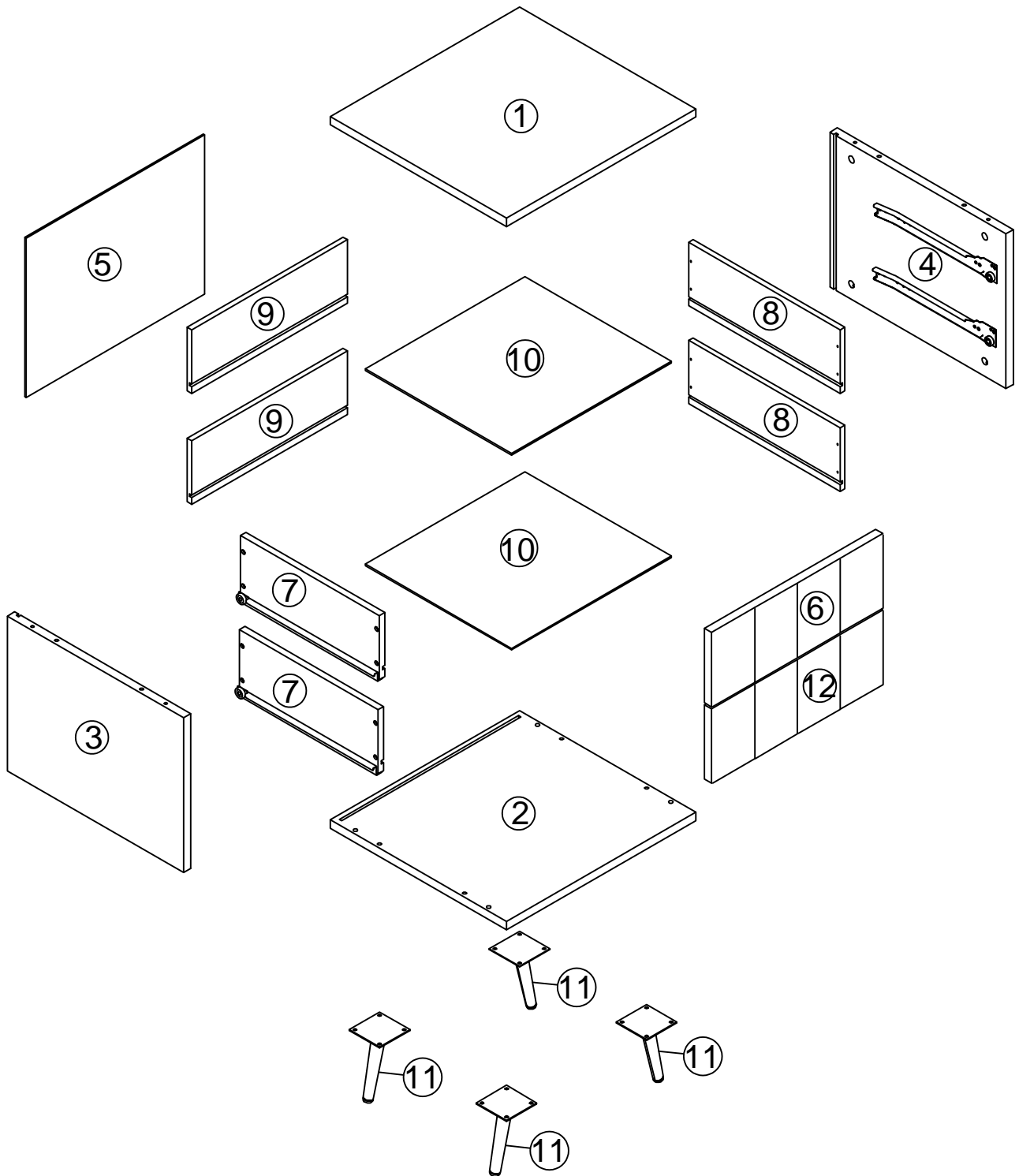



# ASSEMBLY INSTRUCTION

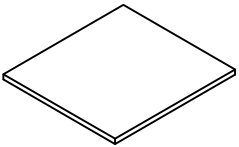
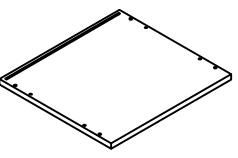
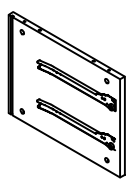
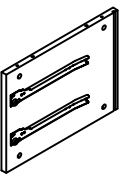
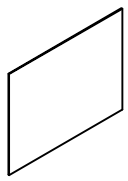
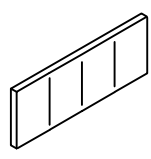
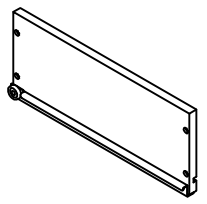
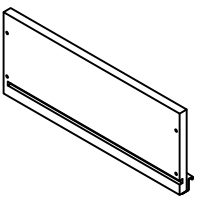
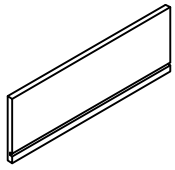
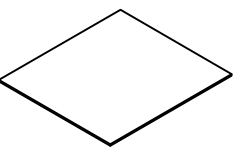
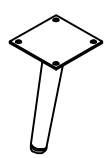
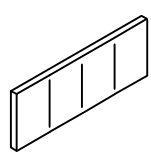

# Part List

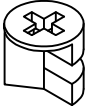
<p>1</p>  <p>Top Panel - 1pc</p>	<p>2</p>  <p>Bottom Panel - 1pc</p>	<p>3</p>  <p>Side Panels - 2pcs</p>
<p>4</p>  <p>Side Panels - 2pcs</p>	<p>5</p>  <p>Back Panel - 1pc</p>	<p>6</p>  <p>Upper-Drawers - Font Panel - 1pc</p>
<p>7</p>  <p>Drawers - Side Panels - 2pcs</p>	<p>8</p>  <p>Drawers - Side Panels - 2pcs</p>	<p>9</p>  <p>Drawers - Back Panels - 2pcs</p>
<p>10</p>  <p>Drawers - Bottom Panels - 2pcs</p>	<p>11</p>  <p>Metal Legs - 4pcs</p>	<p>12</p>  <p>Lower drawer- Font Panel - 1pc</p>

# Hardware List

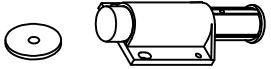
<b>A</b>  Link 1 -8Pcs	<b>B</b>  Link 2 -8Pcs	<b>C</b>  Ø8 x 30 mm Wood Dowel 8pcs
<b>D</b>  M4 x 30 mm Wood Screws 16pcs	<b>E</b>  M4 x 15 mm Wood Screws 26 pcs	<b>F</b>  Open latch - 2pcs

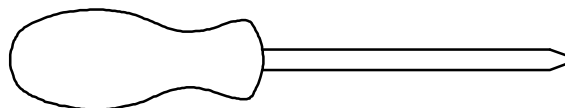



**Assembly Tools Required (Not Included)**

# STEP 1-1: Following below illustration:

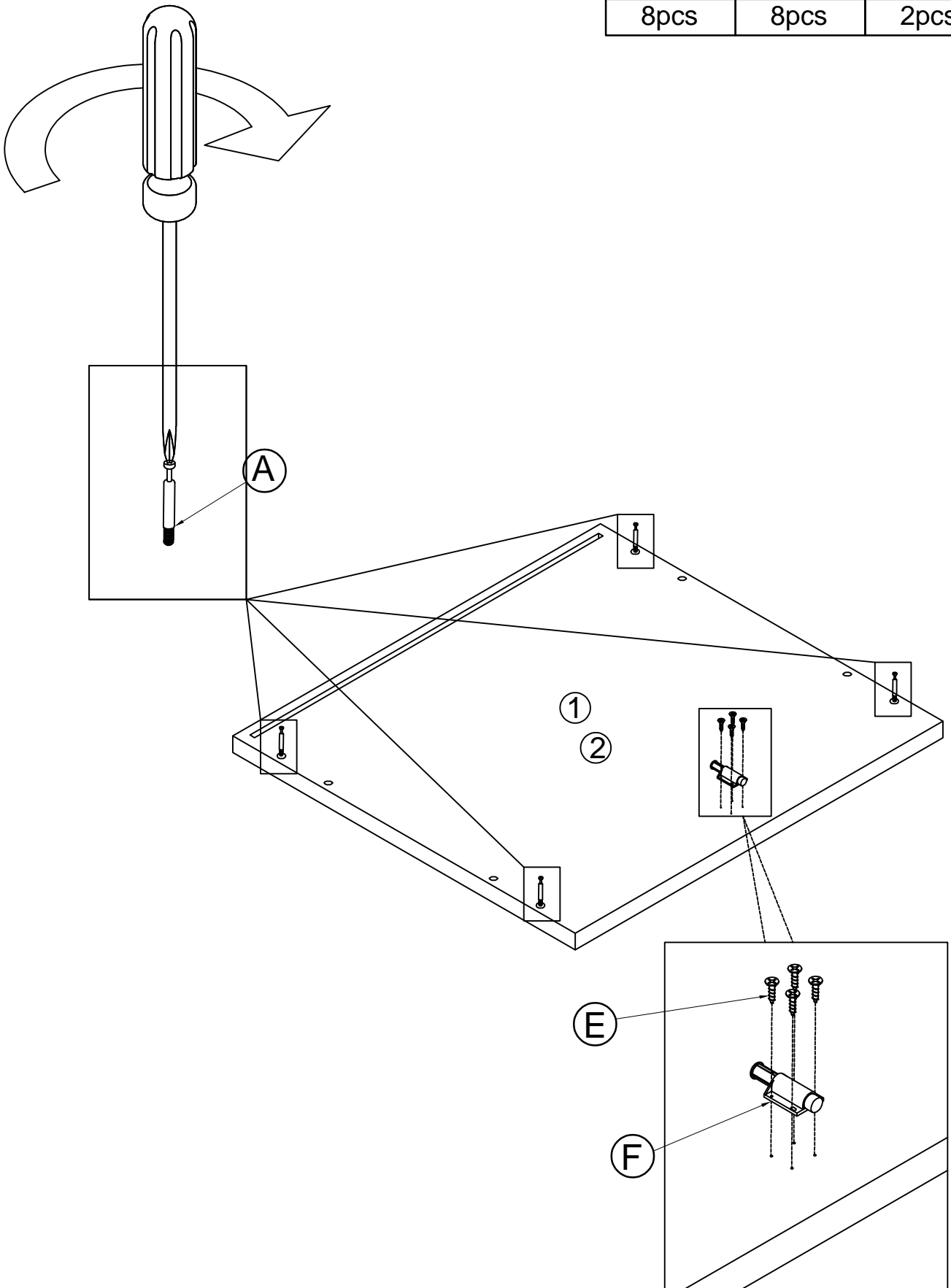
A	E	F
8pcs	8pcs	2pcs



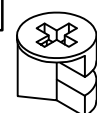

# STEP 2: Following below illustration:

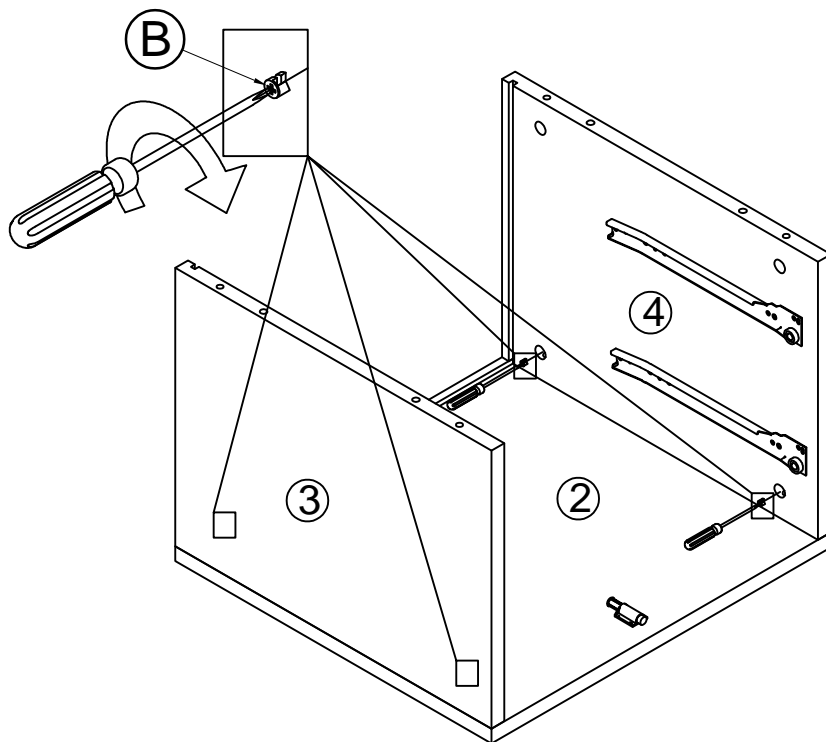
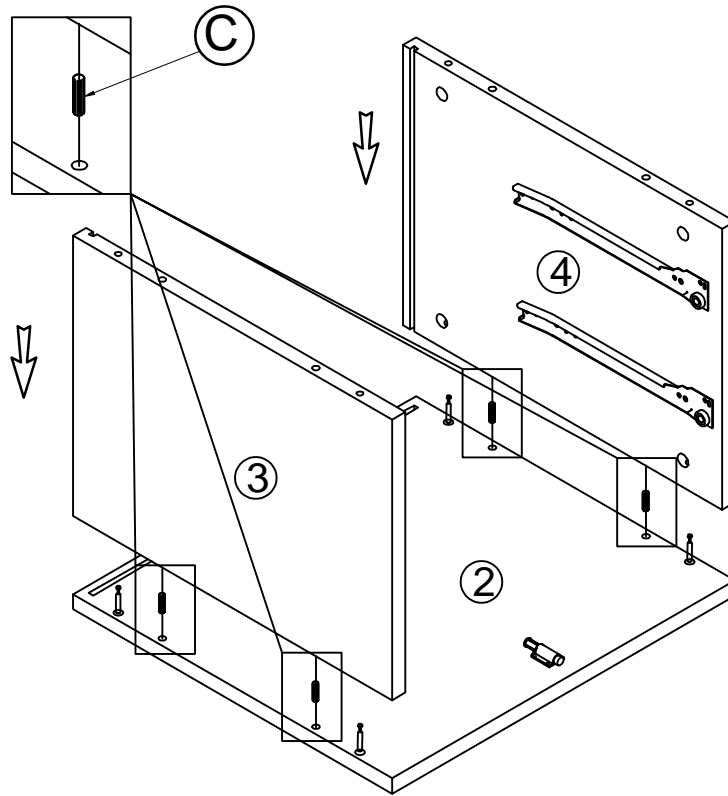
<b>B</b> 	<b>C</b> 
4pcs	4pcs



**STEP 3:** Following below illustration:

<b>B</b> 	<b>C</b> 
4pcs	4pcs

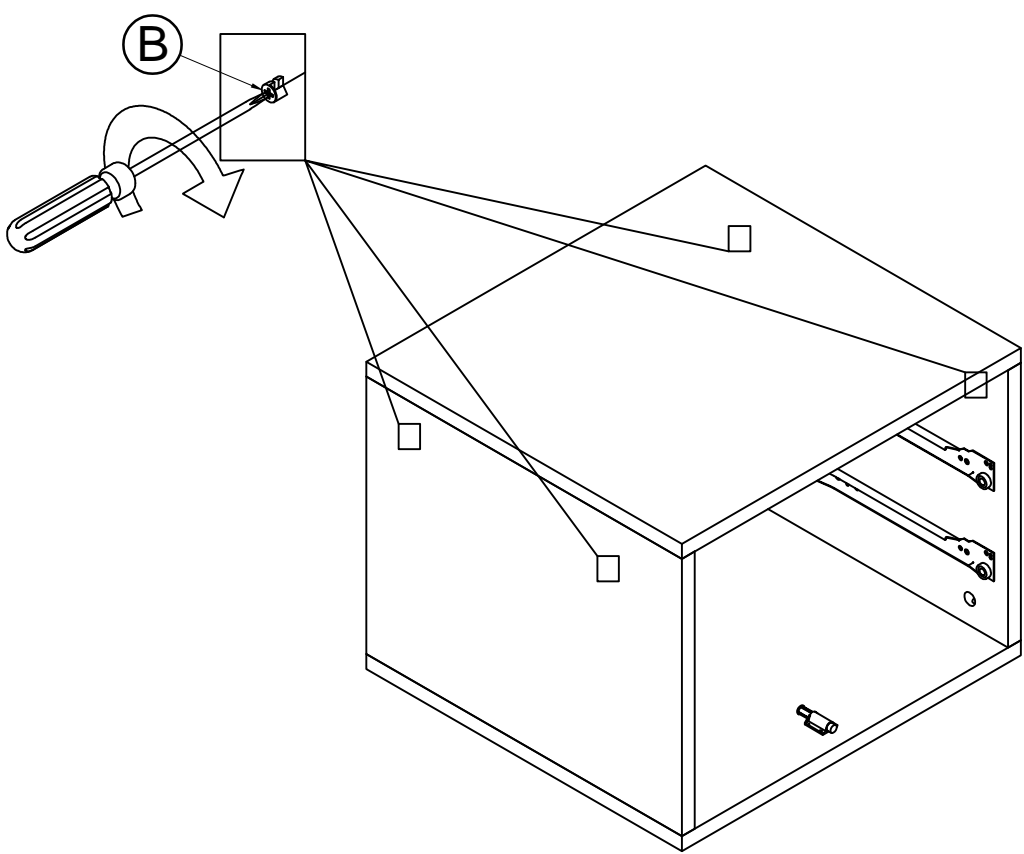
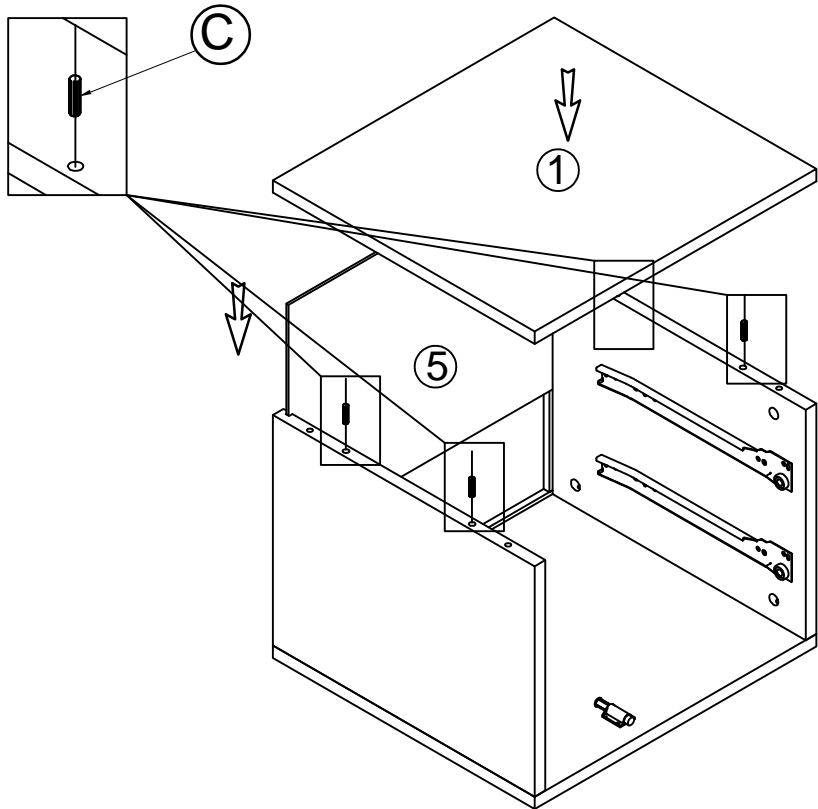

**STEP 4:** Following below illustration:

**E**



16 pcs

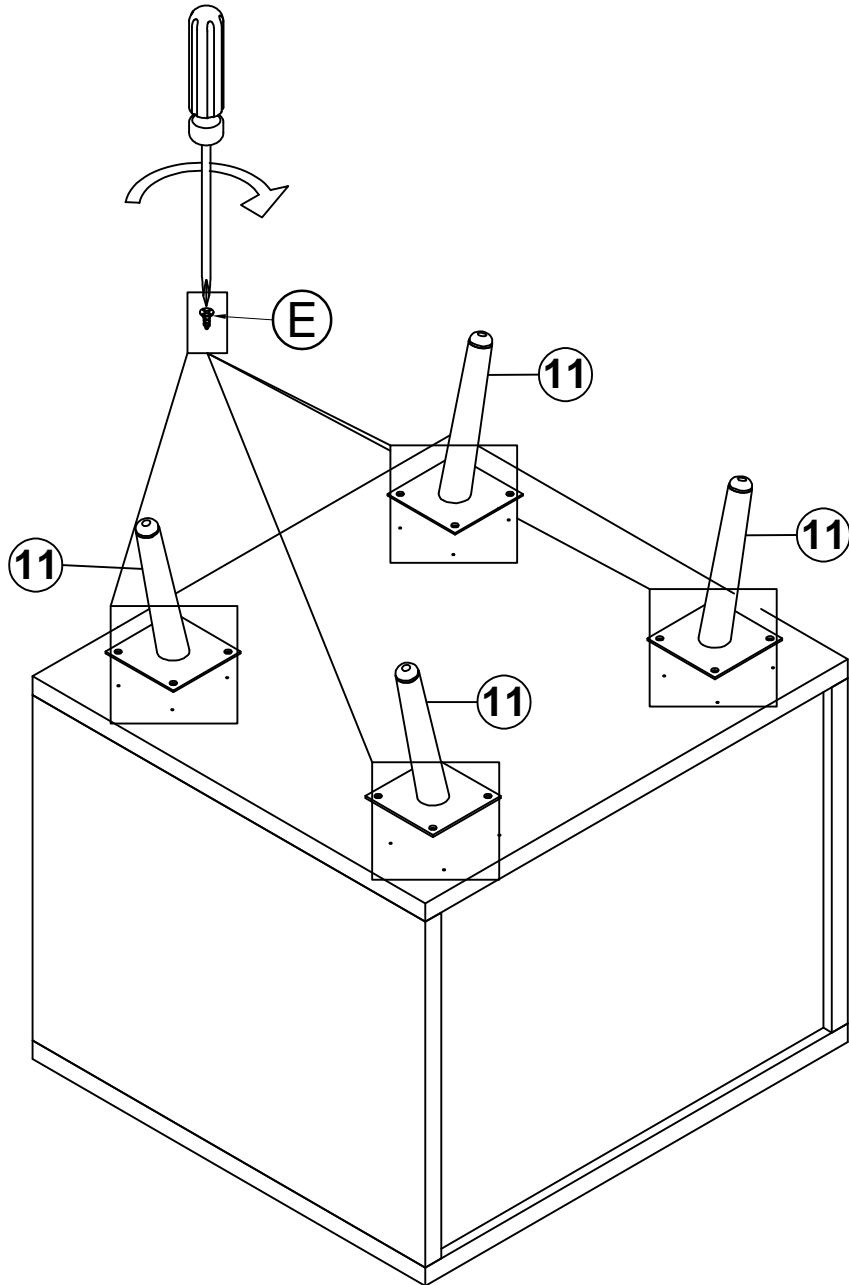

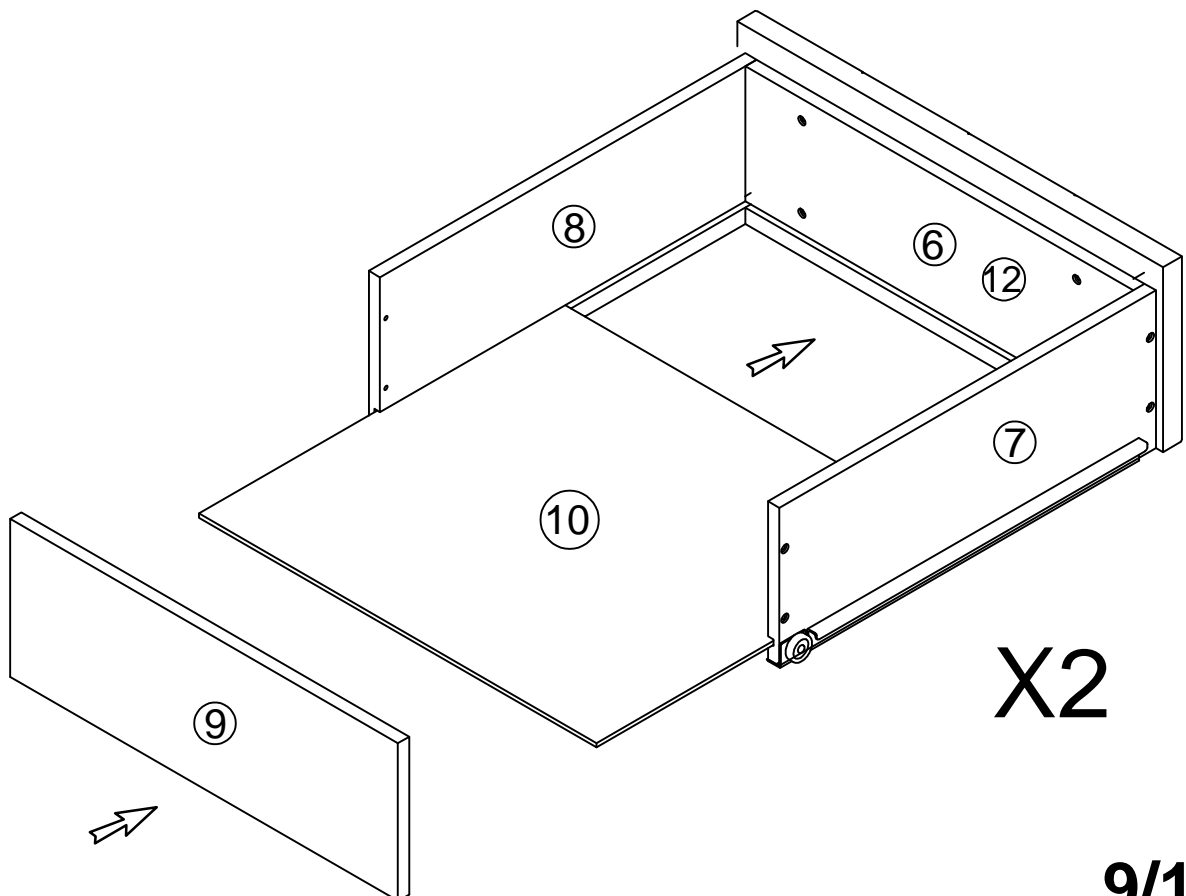
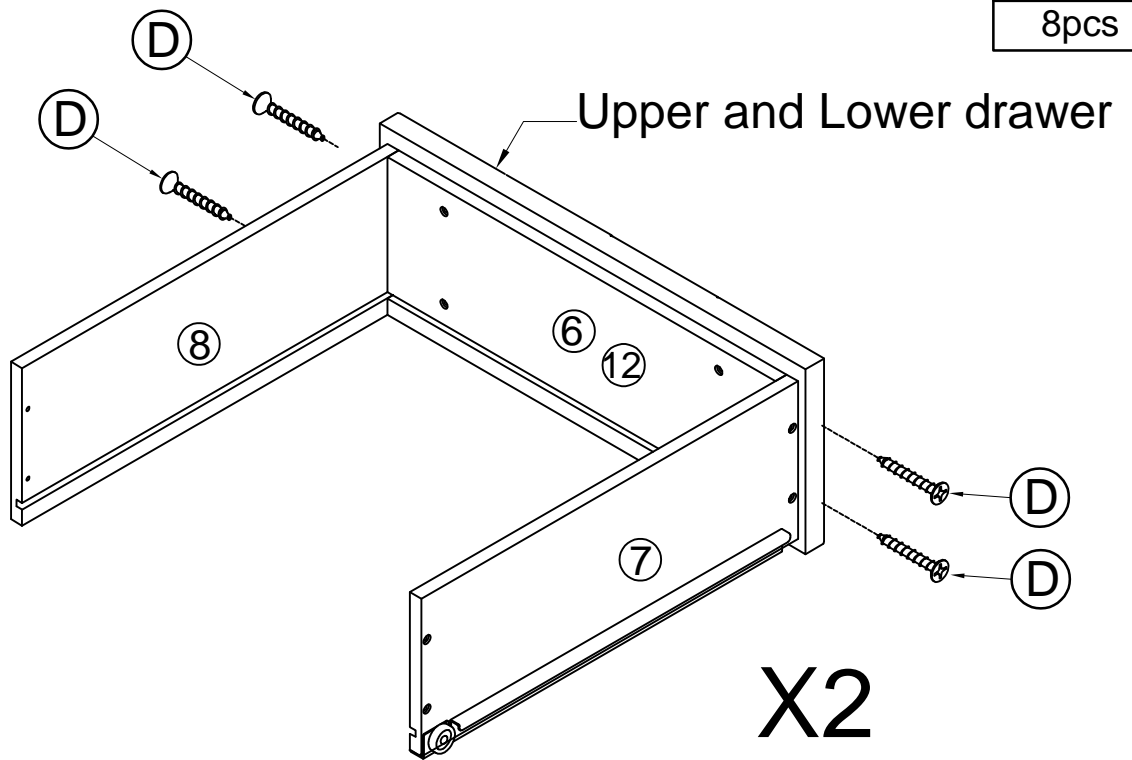

**STEP 5:** Following below illustration:

D	
8pcs	

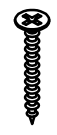

# STEP 6: Following below illustration:

<b>E</b>		<b>F</b>		<b>D</b>	
2 pcs		2 pcs		8 pcs	

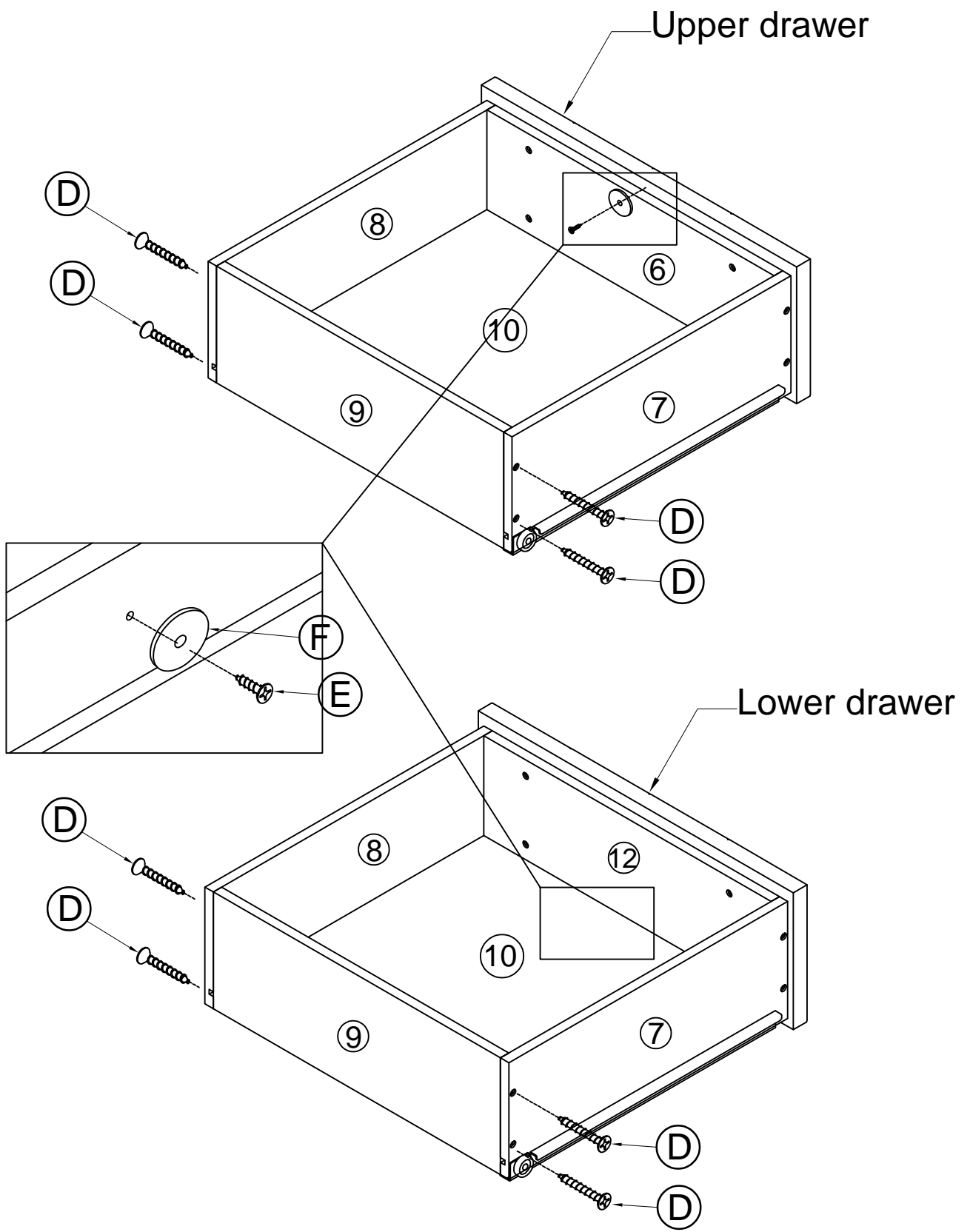

**STEP 7:** Following below illustration:

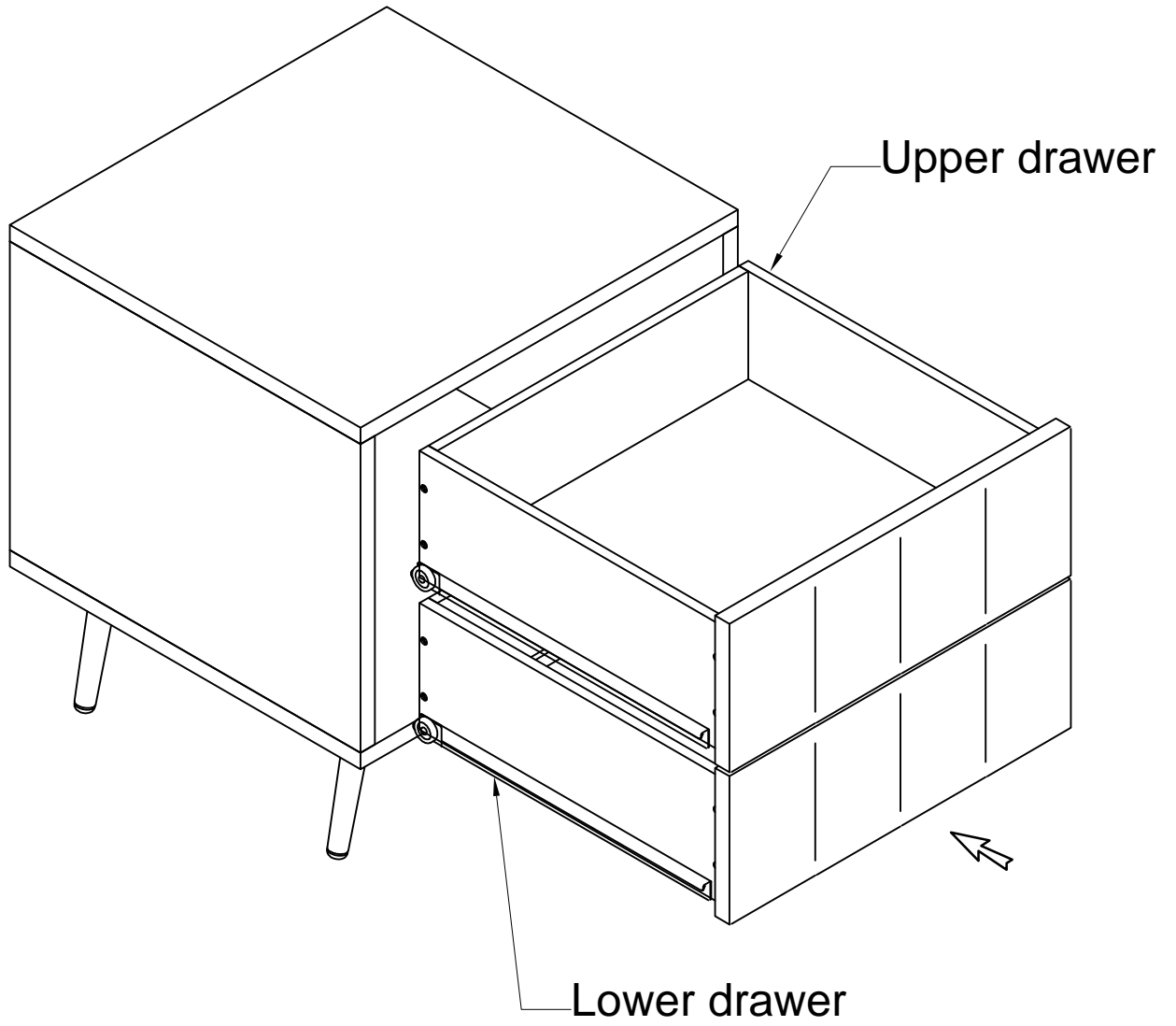

FINISH

