

ASSEMBLY INSTRUCTIONS

Instructions de montage

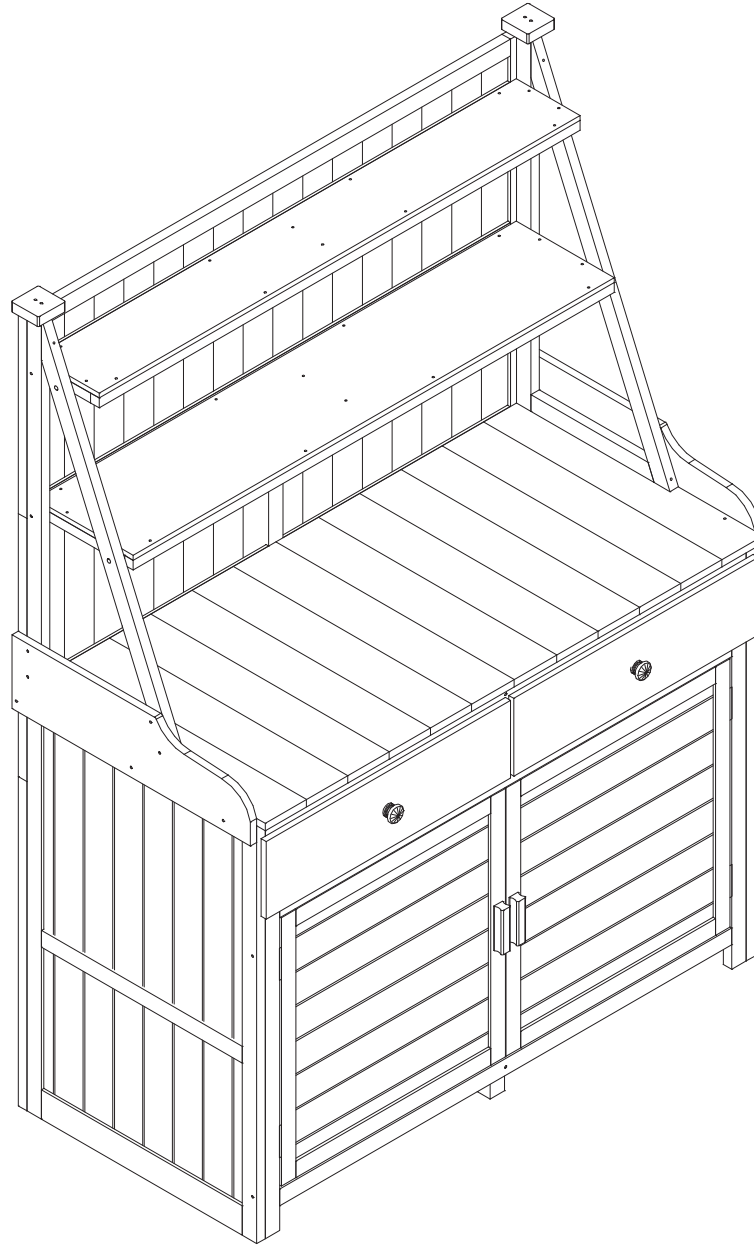

IMPORTANT NOTE :

- ① PLACE ALL PARTS ON A CLEAN AND SMOOTH SURFACE SUCH AS A RUG OR CARPET TO AVOID THE PARTS FROM BEING SCRATCHED.
- ② BEFORE YOU BEGIN, KINDLY FOLLOW THE ASSEMBLY INSTRUCTIONS STEP BY STEP.
- ③ DO NOT TIGHTEN ALL SCREWS AND BOLTS UNTIL THIS ITEM IS FULLY SET-UP.

NOTE IMPORTANTE:



- ① placez toutes les pièces sur une SURFACE propre et lisse telle qu'un tapis ou un tapis pour éviter les pièces d'être rayées.
- ② avant de commencer, veuillez suivre les instructions d'assemblage étape par étape.
- ③ Ne serrez pas toutes les vis et les boulons tant que cet article n'est pas entièrement installé.

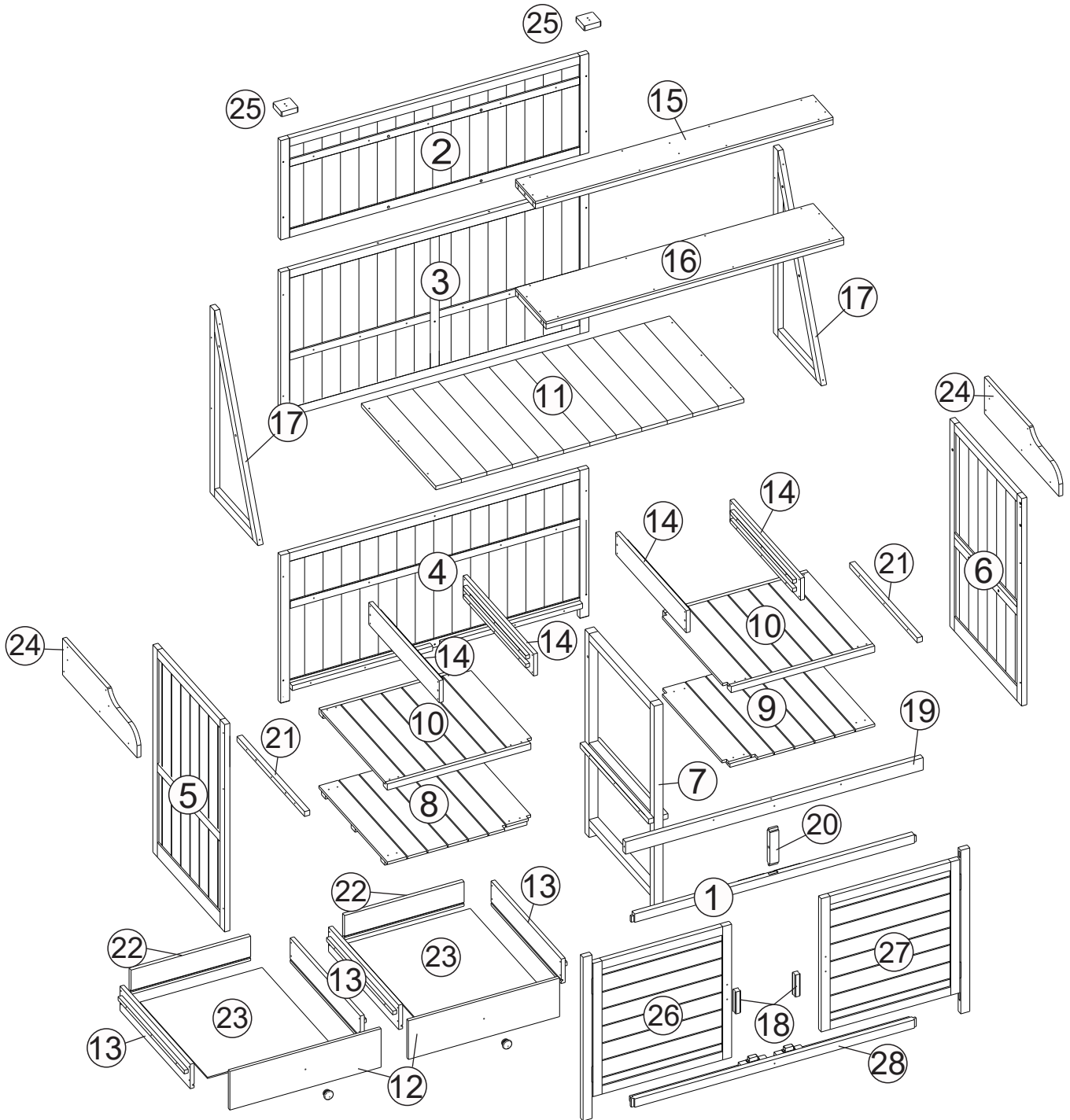





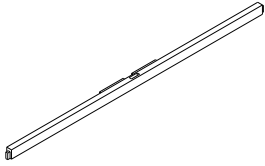
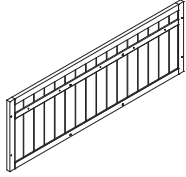
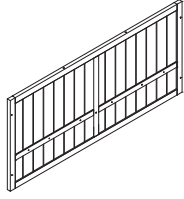
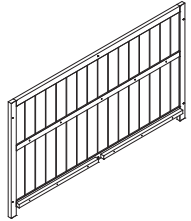
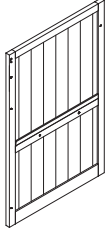
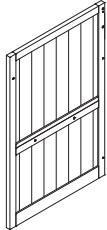
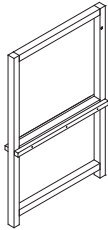
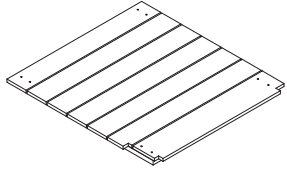
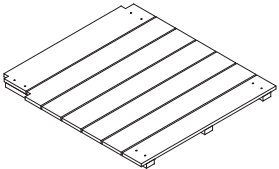
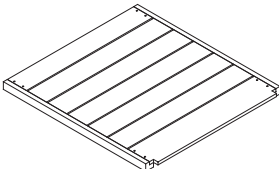
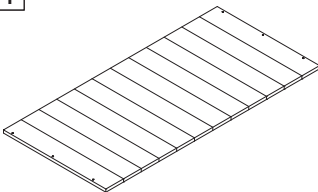
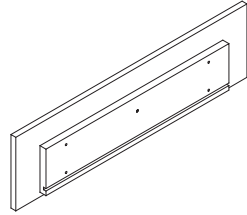
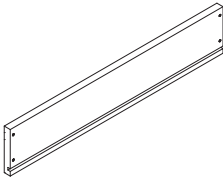
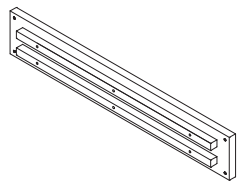
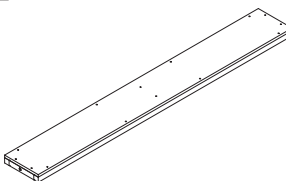
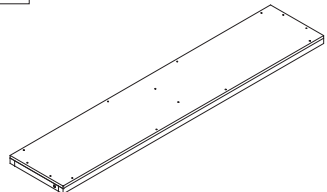
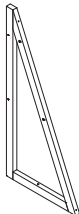

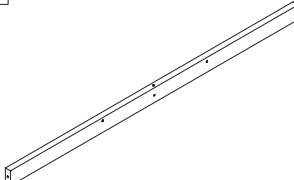
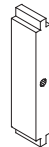
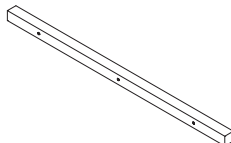
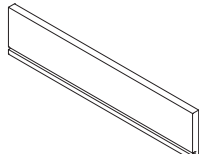
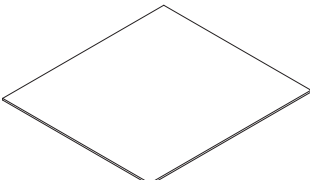
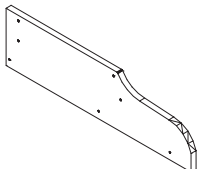
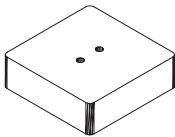
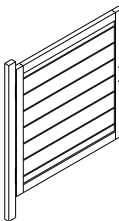
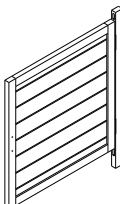
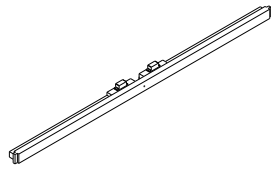

Detail View Vue détaillée

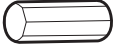

Hardware list
Liste du matériel

Part List
Liste des pièces

1 	2 	3 	4 
Upper bar of front pane- 1pc	Upper back panel- 1pc	Middle back panel- 1pc	Lower back panel- 1pc
5 	6 	7 	8 
Left panel - 1pc	Right panel - 1pc	Middle panel - 1pc	Bottom panel 1 - 1pc
9 	10 	11 	12 
Bottom panel 2 - 1pc	Shelves - 2pcs	Table top - 1pc	Front part of drawer - 2pcs
13 	14 	15 	16 
Side part of drawer - 4pcs	Support plate of drawer - 4pcs	Upper storage board - 1pc	Lower storage board - 1pc
17 	18 	19 	20 
Triangular support part - 2pcs	Handle - 2pcs	Horizontal bar of front panel - 1pc	Vertical bar of front panel- 1pc
21 	22 	23 	24 
Slat of support - 2pcs	Back part of drawer - 2pcs	Bottom of drawer - 2pcs	Side panel of table - 2pcs
25 	26 	27 	28 
Wood block - 2pcs	Left door of front panel- 1pc	Right door of front panel- 1pc	Lower bar of front panel - 1pc

A  φ3.5x60 Ph zinc screws 8+1pcs	B  φ3.5x40 Ph zinc screws 26+1pcs	C  φ3.0x38 Ph zinc screws 14+1pcs	D  φ3.0x30 Ph zinc screws 56+1pcs
E  Wood dowel 16pcs	F  M6*45 Ph zinc bolt 8+1pcs	G  M4*30 Ph zinc bolt 2+1pcs	H  Door Knob 2pcs
I  φ3.5x16 Ph zinc screws-4+1pcs	J  Angle steel-2pcs	K  Ground nail-2pcs	

ASSEMBLY TOOLS REQUIRED(NOTINCLUDED)
 Outils d'assemblage requis (non inclus)



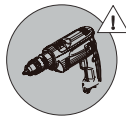

PLEASE BE CAREFUL DO NOT DAMAGE THE HOLE POSITION WHEN YOU USE POWERTOOLS!
 Veuillez faire attention à ne pas endommager la position du trou lors de l'utilisation d'outils électriques!

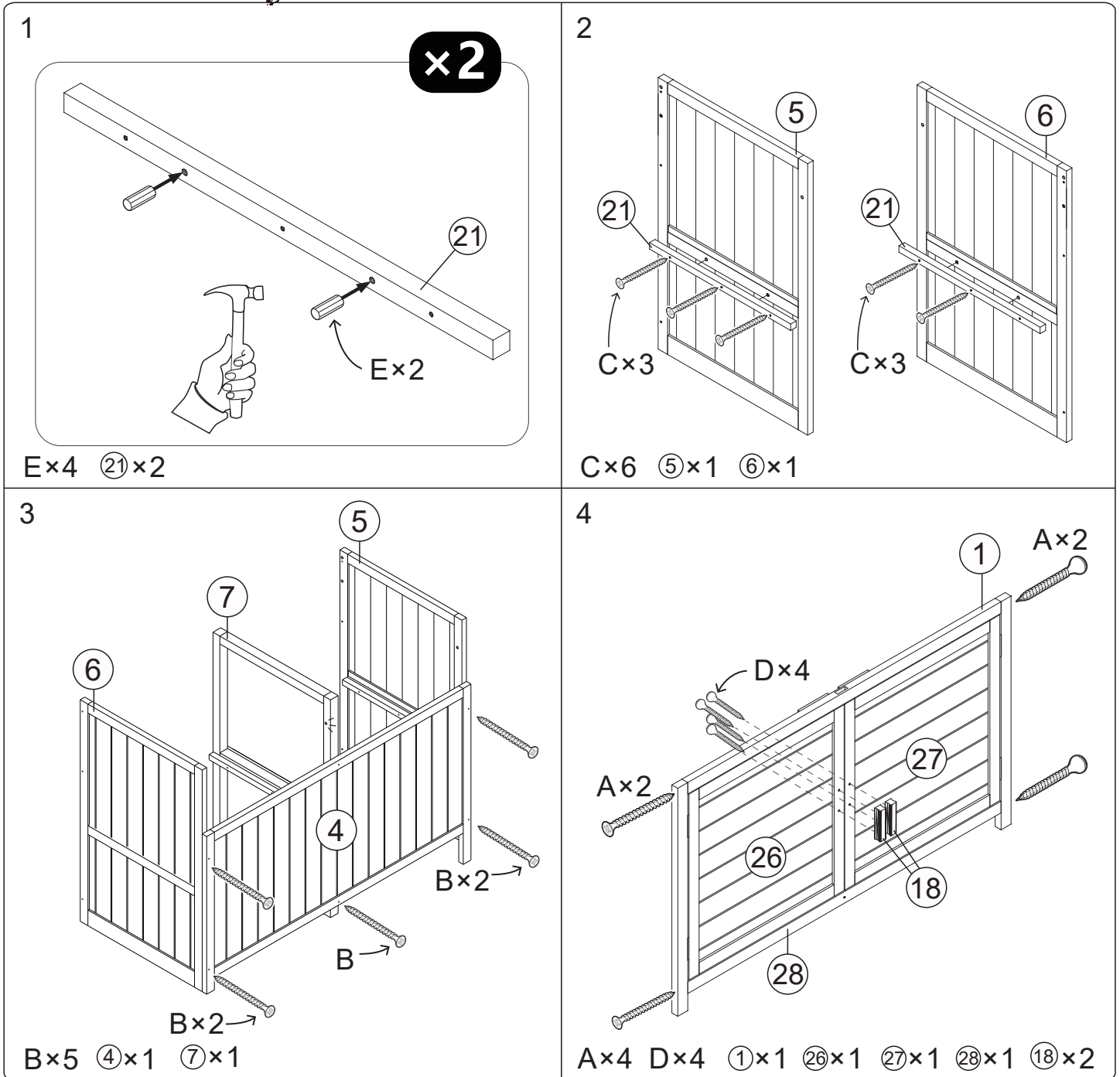

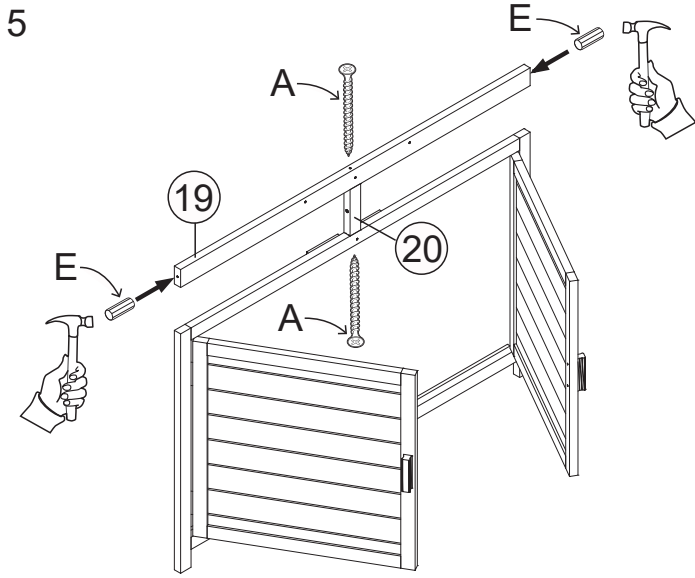

A×2 E×2 19×1 20×1

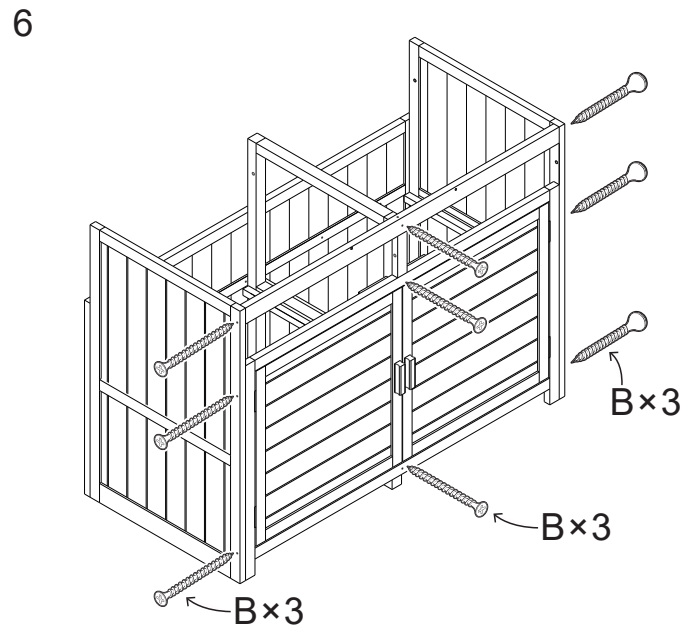

B×9

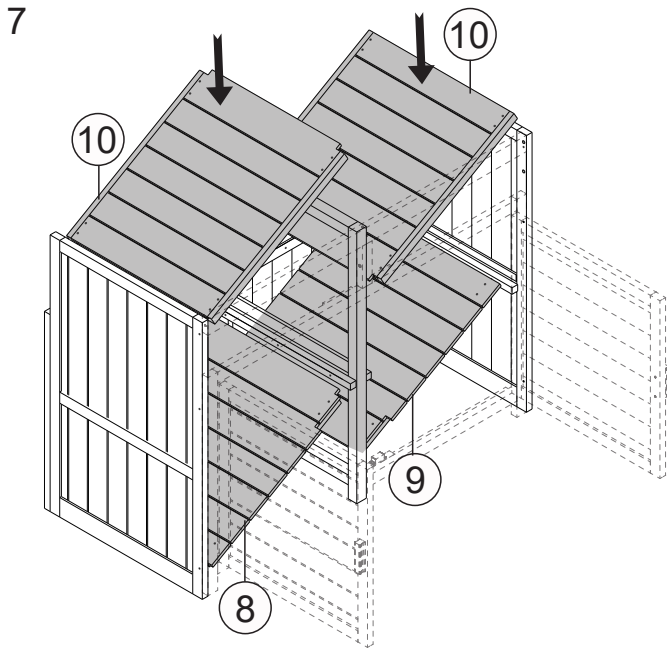

8×1 9×1 10×2

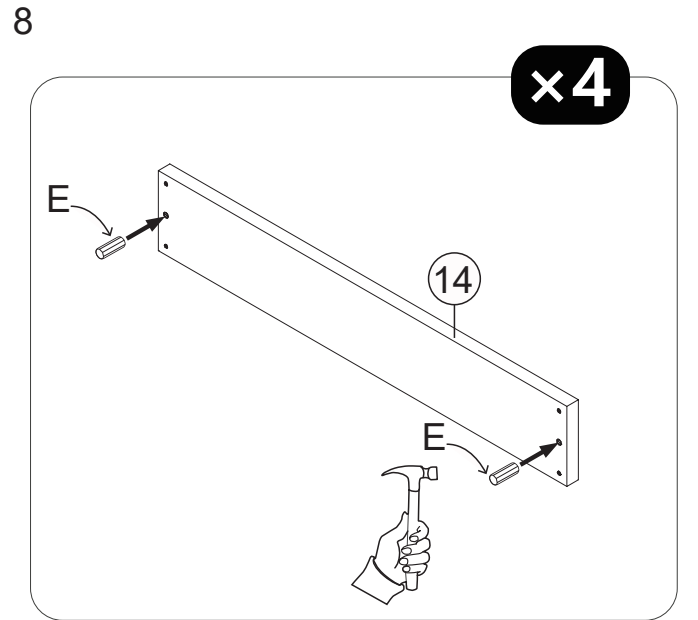

E×8 14×4

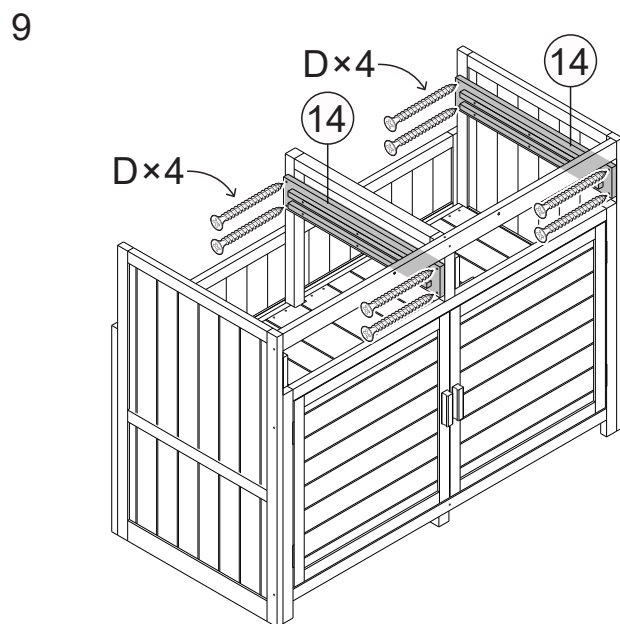

B×1 D×16

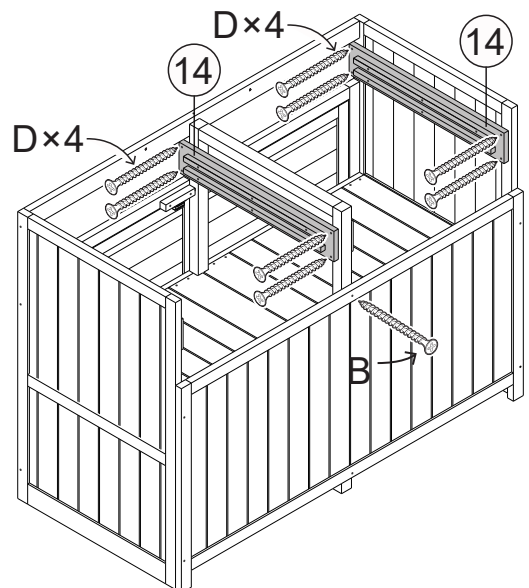

10

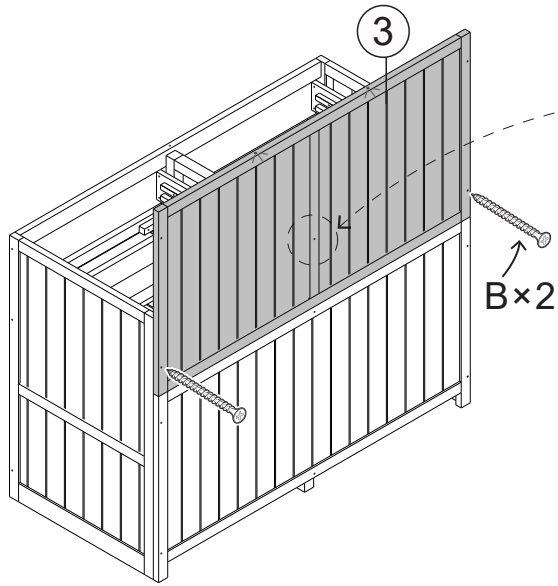

Bx2 ③x1

11

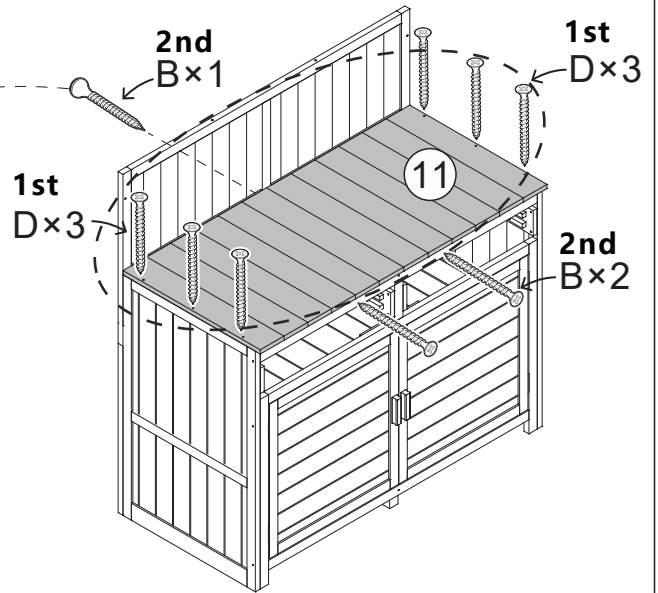

Bx3 Dx6 ⑪x1

12

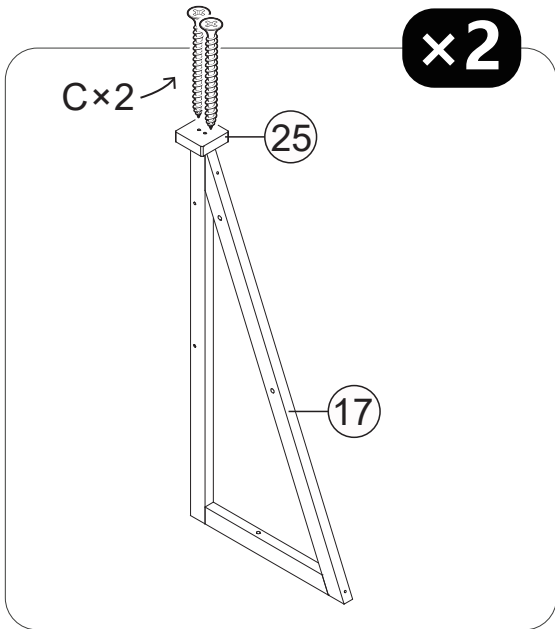

Cx4 ⑰x2 ⑳x2

13

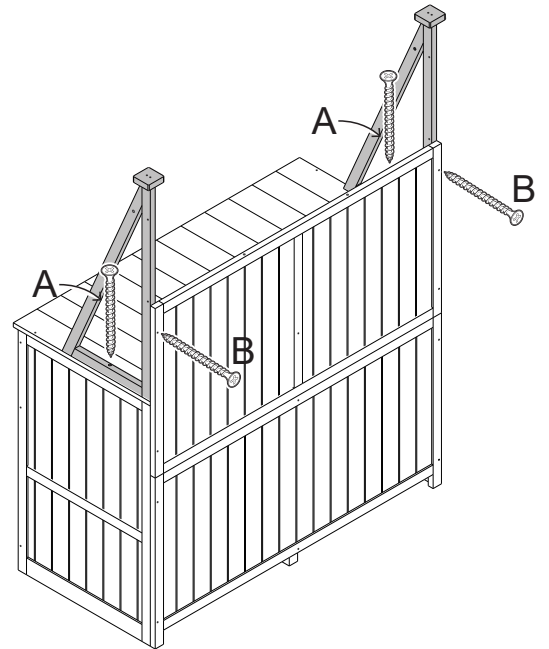

Ax2 Bx2

14

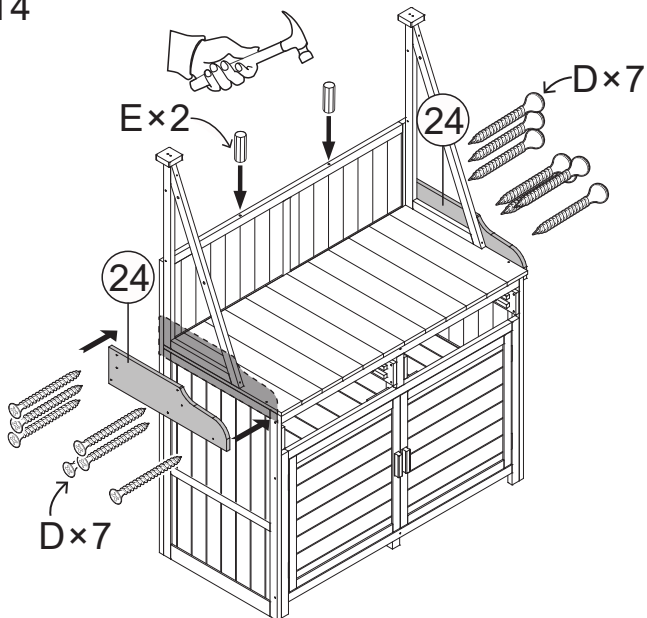

Dx14 Ex2 ⑳x2

15

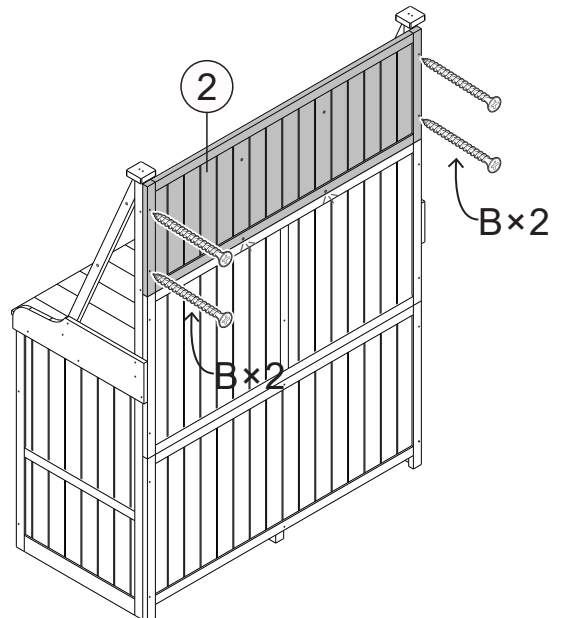

Bx4 ②x1

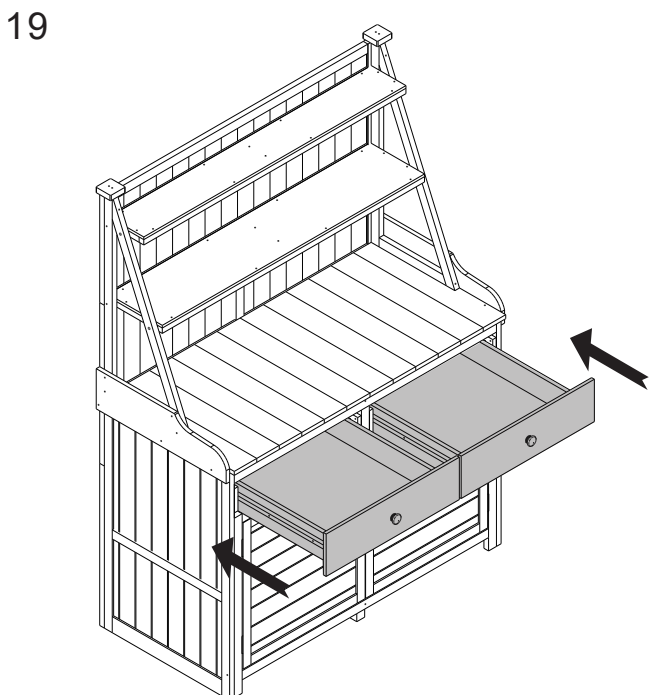
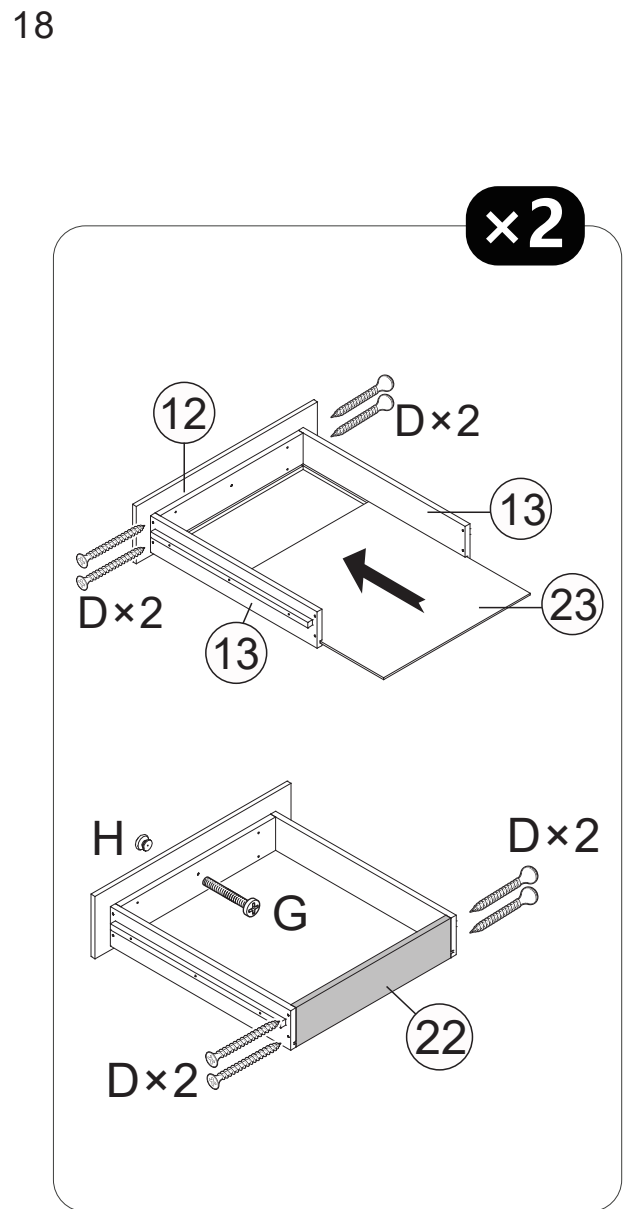
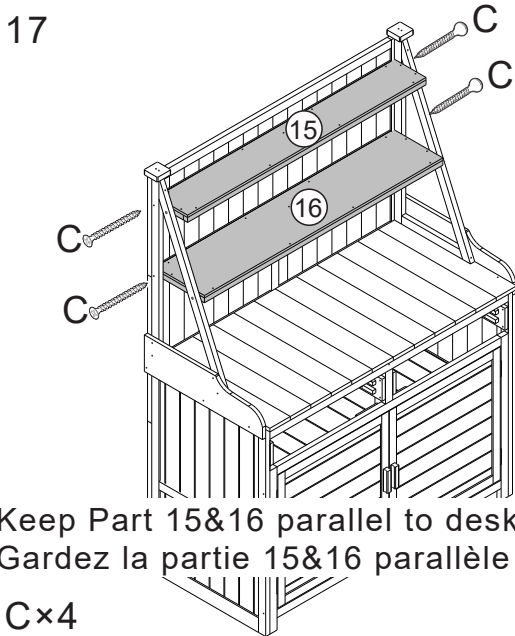
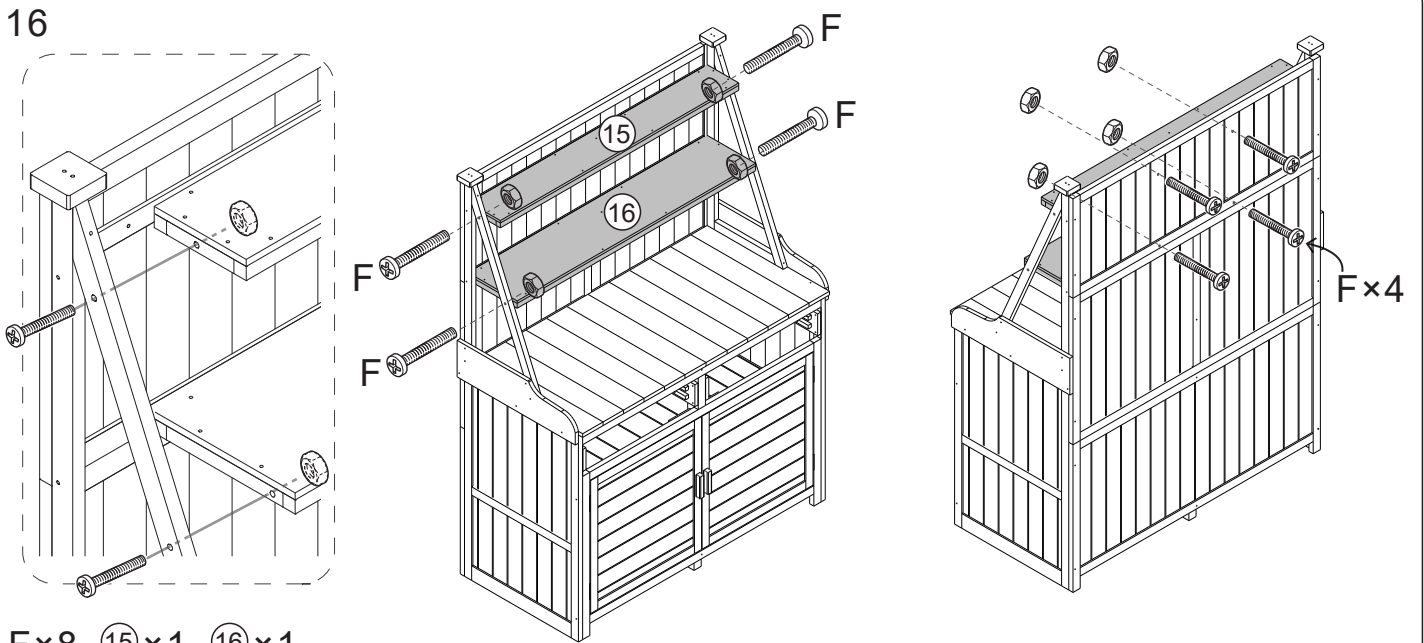

D x 16 G x 2 H x 2 12 x 2 13 x 4 22 x 2 23 x 2

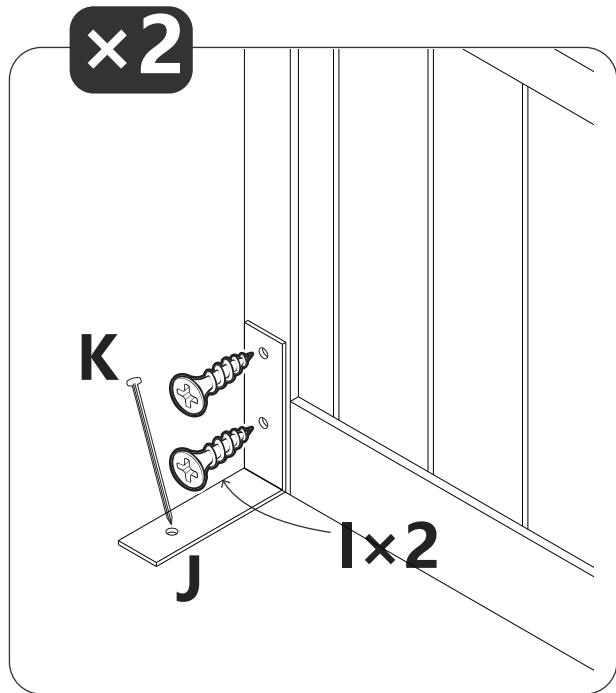
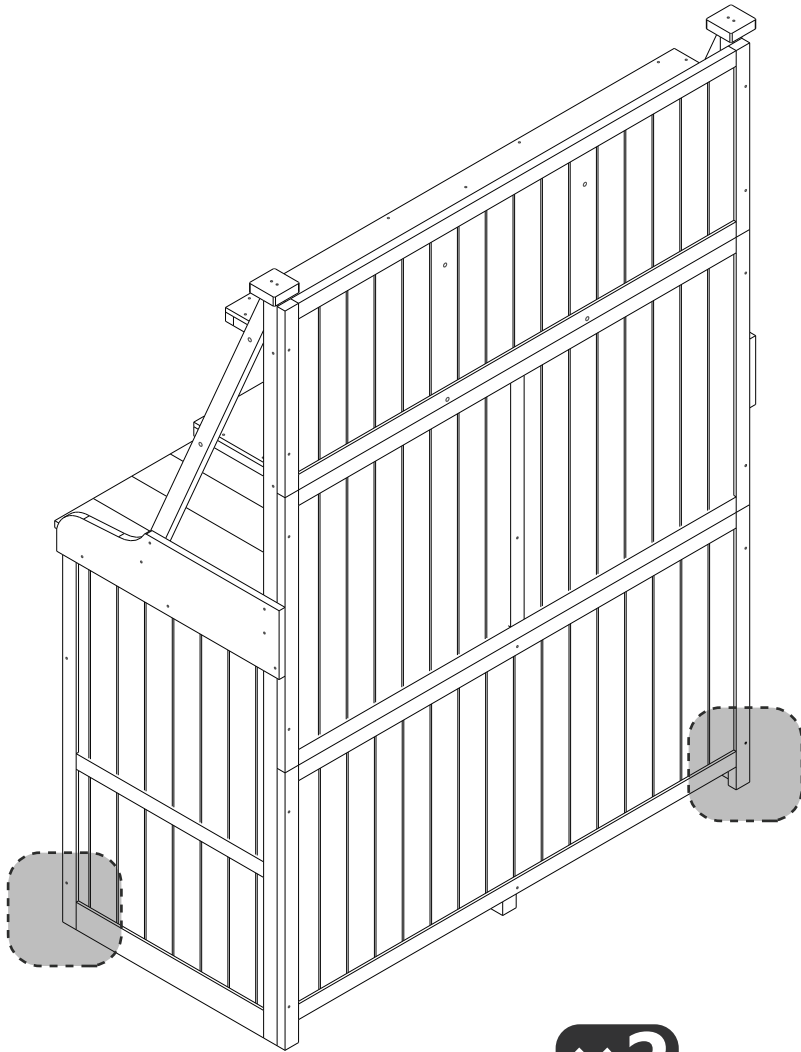

Kx2 Jx2 Ix4

Done
L'achèvement du