













Read this instruction carefully. See hardware and furniture part list for guidance. Be sure all parts are complete, before you assemble. Place all wooden furniture parts on a clean and flat soft surface to prevent from being scratched. Follow the figure to start assembling.

**CAUTIONS :** 1. Do not FULLY - TIGHTEN the nut or nut bolt until all nut or bolt is ready assembled.  
 2. Do not OVER - TIGHTEN the nut or bolt to avoid causing damages to the thread.  
 3. Keep all hardware parts out of reach of children.

**NOTE :** THE LIST AND QUANTITY SHOWN ARE FOR 1 UNIT ASSEMBLY.

Tool needed : Screwdriver (not provider).

PART LIST			
ITEM	DESCRIPTION	BOX	QTY
A	HEADBOARD	1	1 PC
B	FOOTBOARD	2	1 PC
C	BED LEG	2	4 PCS
D	SIDE RAIL	2	2 PCS
E	CENTER RAIL	2	1 PC
F	CENTER SUPPORT LEG	2	3 PCS
G	CENTER SUPPORT	2	2 PCS
H	BED SLAT	2	26 PCS

HARDWARE LIST (BOX : 2)			
ITEM	DESCRIPTION		QTY
1	JCBC BOLT M6 x 20mm		4 PCS
2	M6 FLAT WASHER		4 PCS
3	M6 SPRING WASHER		4 PCS
4	M8 SPRING WASHER		2 PCS
5	WOOD SCREW M4 x 20mm		10 PCS
6	WOOD SCREW M3.5 x 16mm		8 PCS
7	5/16" HEX NUT		2 PCS
8	VMB 3087 (BLACK)		2 PCS
9	SPANNER (13mm)		1 PC
10	BED SLAT SIDE FITTER		26 PCS
11	BED SLAT CENTER FITTER		13 PCS
12	M4 ALLEN KEY (BALL SHAPE)		1 PC
13	M5 ALLEN KEY (BALL SHAPE)		1 PC

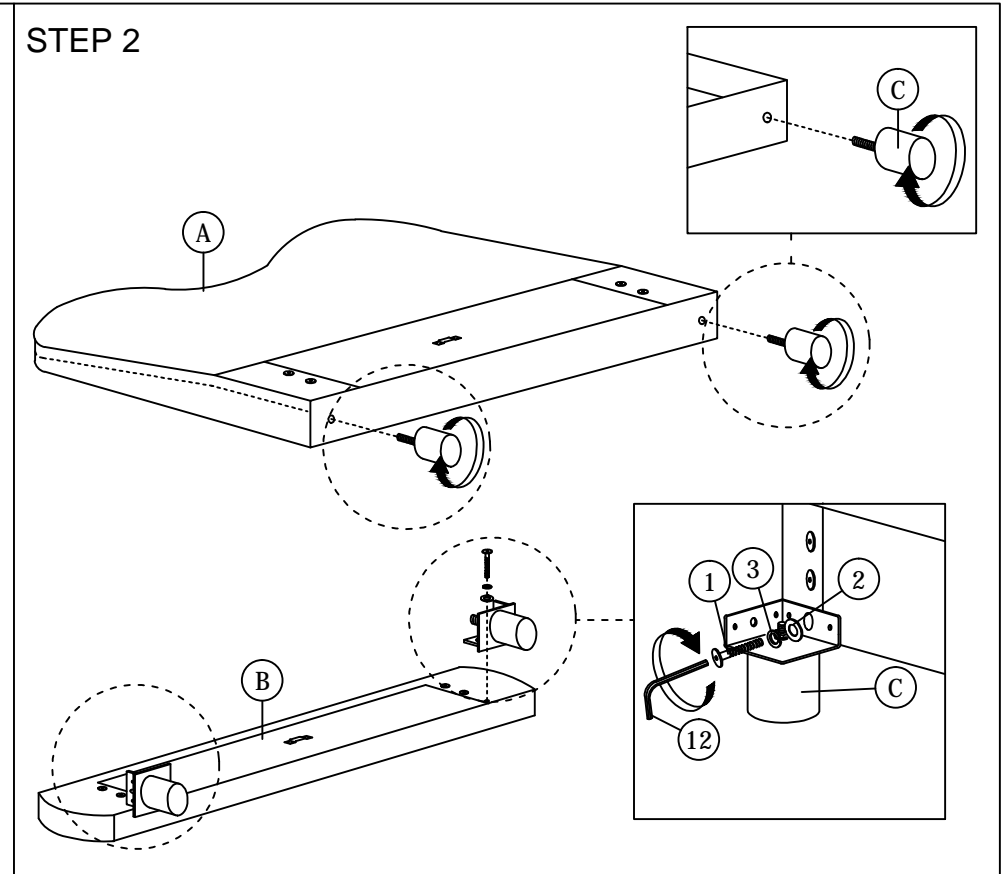
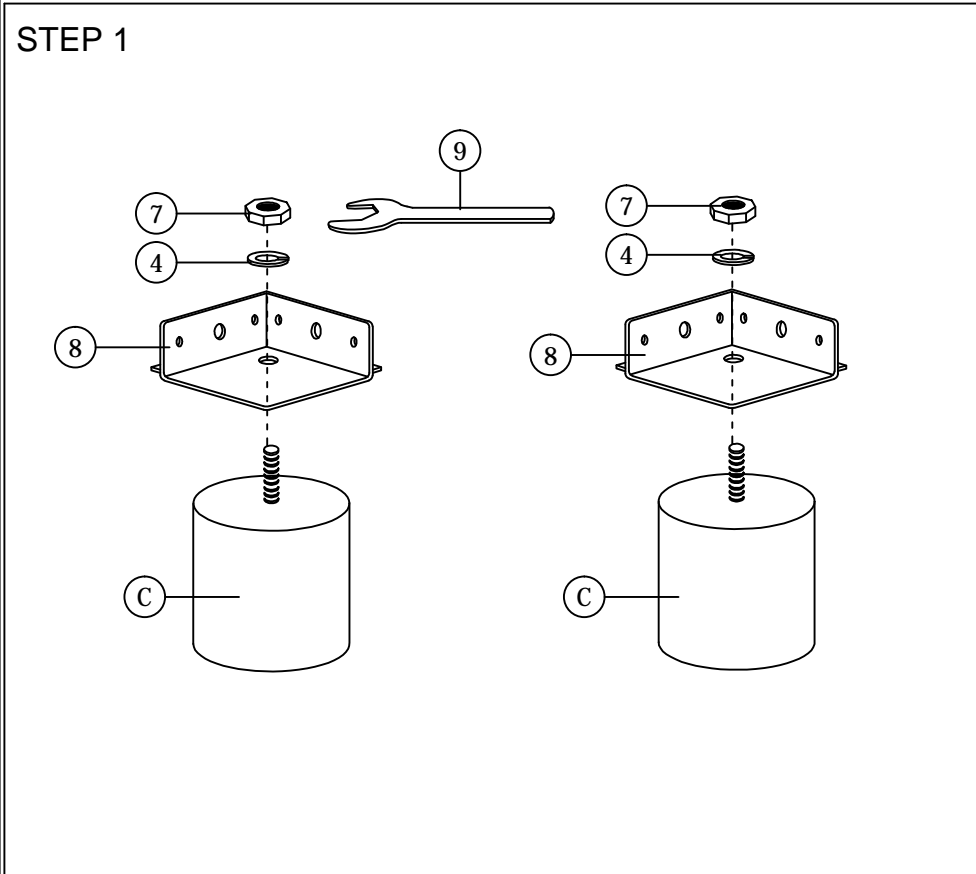

# ASSEMBLY INSTRUCTIONS

## STEP 3

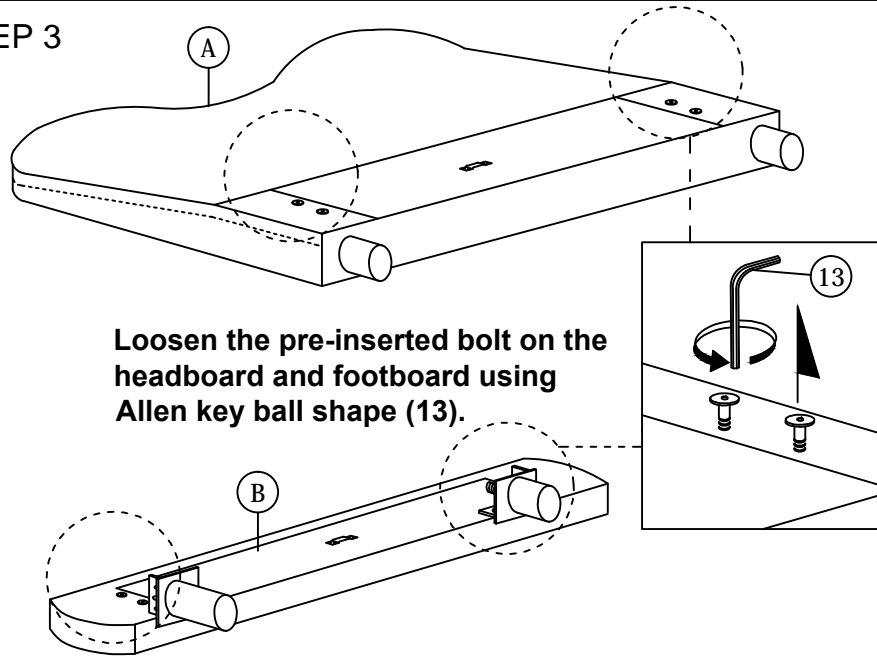

## STEP 4

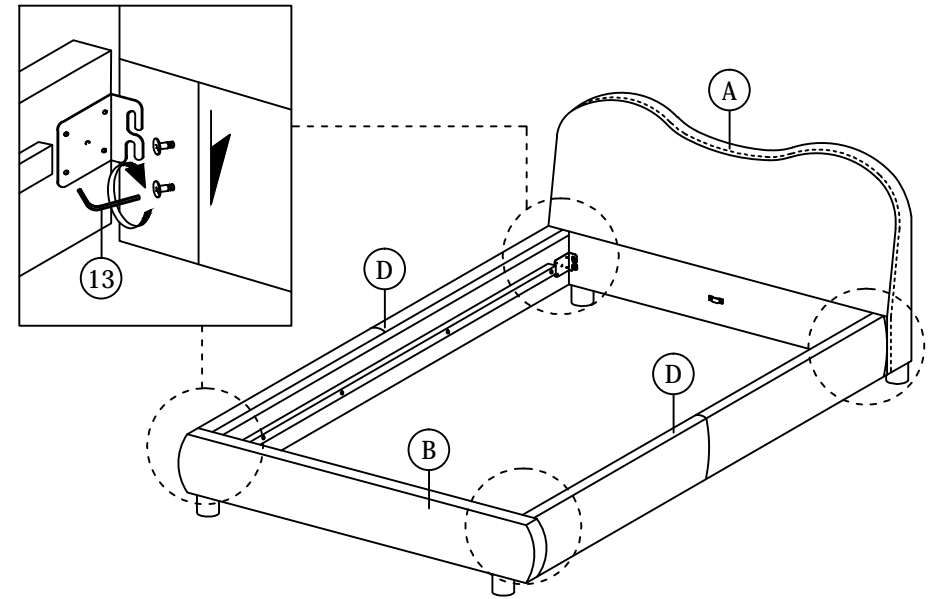

## STEP 5

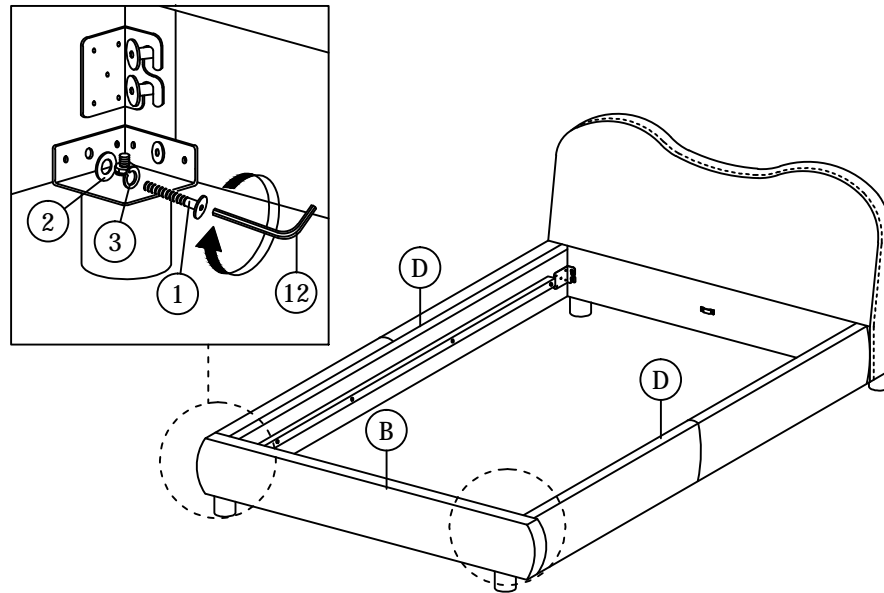

## STEP 6

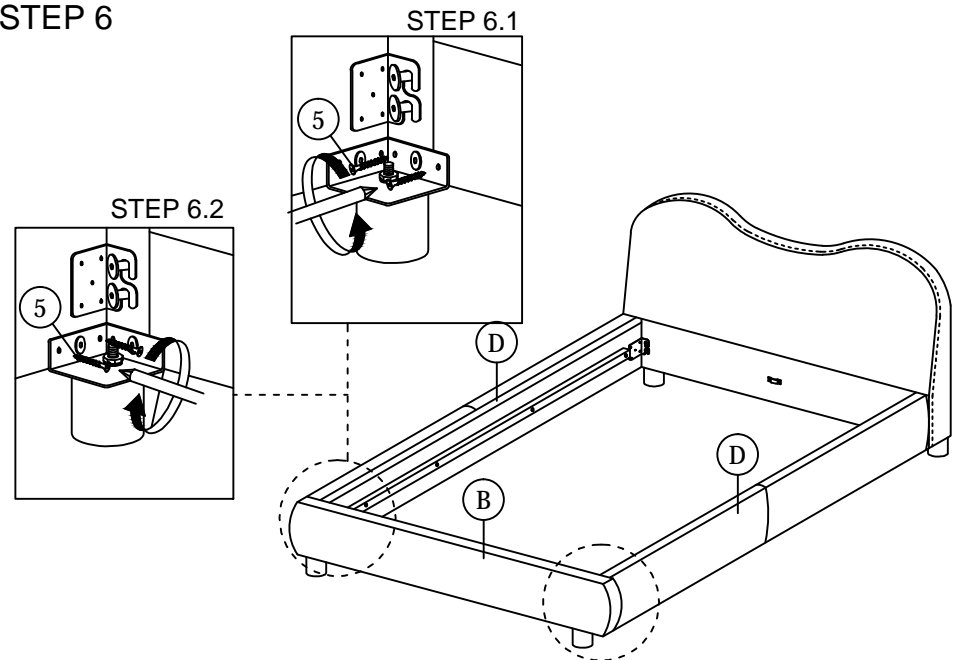

# ASSEMBLY INSTRUCTIONS

## STEP 7

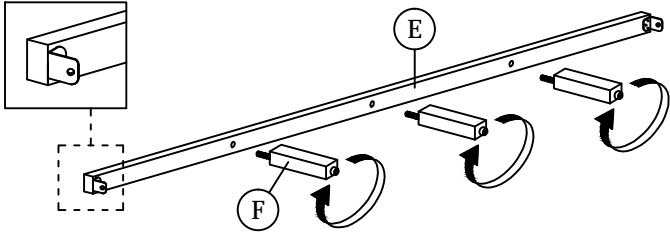

## STEP 8

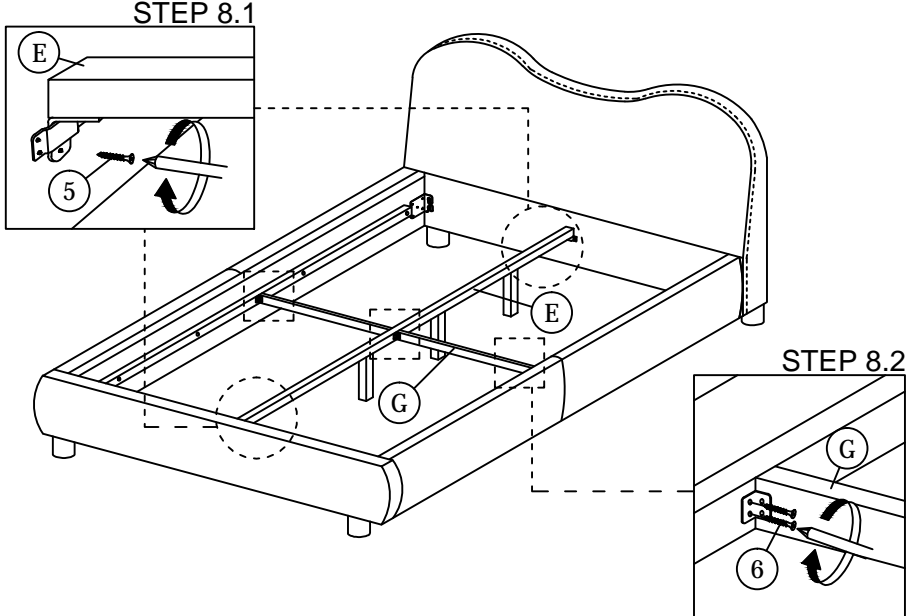

## STEP 9

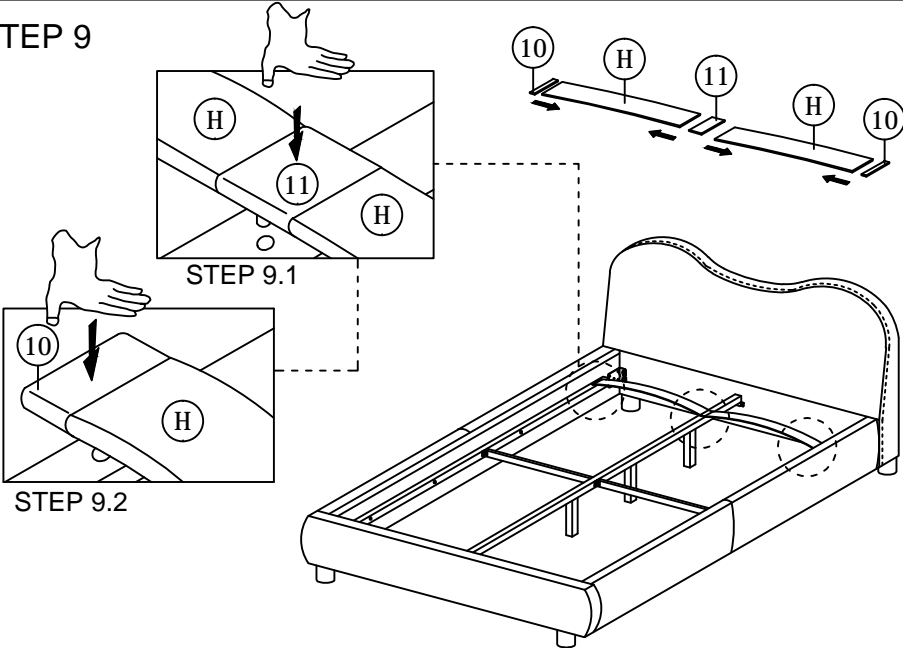

## STEP 10

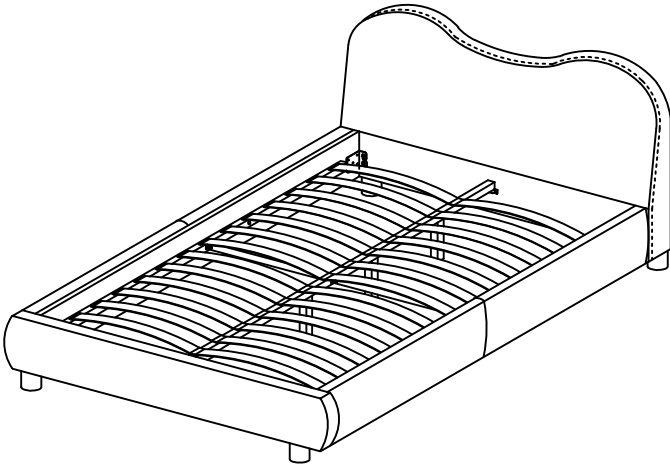

\* When moving the bed position, the center support legs must be adjusted to be straight to avoid any broken problem.