

Test Report

Report No.:RKEYS250314098

Date: Mar.27, 2025

Page 1 of 65

RED EMC

For

Product:Night Stand

Model:YS-02NS011A

Report No.: RKEYS250314098

Issued for

YUSONG GROUP INC

421 S BROOKHURST ST STE 1312 ANAHEIM 92804-2413 CA US

Issued by

Guangdong KEYS Testing Technology Co.,Ltd.

**Address: Building 1, No.18, Shihuan Road, Dongcheng Subdistrict, Dongguan, Guangdong,
China**



Scan to view
the original file

Guangdong KEYS Testing Technology Co., Ltd.

Address: Building 1, No.18, Shihuan Road, Dongcheng Subdistrict, Dongguan, Guangdong, China
Tel: +86-0769-89798319 <http://www.keys-lab.com> E-mail: info@keys-lab.com

This report is only responsible for the test results of the samples submitted for inspection, and is not responsible for the source of the samples submitted for inspection.
This report shall not be altered, increased or deleted. Without written approval of KEYS, this test report shall not be copied except in full and published as advertisement.

Test Report

Report No.:RKEYS250314098

Date: Mar.27, 2025

Page 2 of 65

TABLE OF CONTENTS

1. TEST CERTIFICATION	3
2. TEST SUMMARY	4
3. TEST SITE	5
3.1. TEST FACILITY	5
3.2. MEASUREMENT UNCERTAINTY	5
3.3. LIST OF TEST AND MEASUREMENT INSTRUMENTS	5
4. EUT DESCRIPTION	9
5. TEST METHODOLOGY	10
5.1. TEST MODE	10
5.2. EUT SYSTEM OPERATION	10
6. SETUP OF EQUIPMENT UNDER TEST	11
6.1. DESCRIPTION OF SUPPORT UNITS	11
6.2. CONFIGURATION OF SYSTEM UNDER TEST	11
7. EMISSION TEST	12
7.1. CONDUCTED EMISSION MEASUREMENT	12
7.2. RADIATED EMISSION MEASUREMENT	16
7.3. RADIATED EMISSION MEASUREMENT (ABOVE 1GHz)	21
7.4. HARMONICS CURRENT MEASUREMENT	25
7.5. VOLTAGE FLUCTUATION AND FLICKS MEASUREMENT	33
8. IMMUNITY TEST	36
8.1. ELECTROSTATIC DISCHARGE (ESD)	39
8.2. RADIATED, RADIO-FREQUENCY, ELECTROMAGNETIC FIELD (RS)	43
8.3. ELECTRICAL FAST TRANSIENT (EFT)	46
8.4. SURGE IMMUNITY TEST	48
8.5. CONDUCTED RADIO FREQUENCY DISTURBANCES (CS)	50
8.6. POWER FREQUENCY MAGNETIC FIELD	52
8.7. VOLTAGE DIP & VOLTAGE INTERRUPTIONS	55
9. PHOTOGRAPHS OF THE TEST CONFIGURATION	58
10. PHOTOGRAPHS OF EUT	60

Test Report

Report No.:RKEYS250314098

Date: Mar.27, 2025

Page 3 of 65

1. TEST CERTIFICATION

Product: Night Stand
Trade mark: YUSONG
Model: YS-02NS011A
Applicant : YUSONG GROUP INC
Address: 421 S BROOKHURST ST STE 1312 ANAHEIM 92804-2413 CA US
Manufacturer: YUSONG
Address: 421 S BROOKHURST ST STE 1312 ANAHEIM 92804-2413 CA US
Sample Received Date: Mar.13, 2025
Test Date: Mar.13, 2025 to Mar.20, 2025
Test Voltage: Rated input:250V~/50Hz/16A/Max3680W/230V~
USB Ouput:5.0Vd.c.2.1A.10.5W Max
Applicable Standards: ETSI EN 301 489-1 V2.2.3 (2019-11)
ETSI EN 301 489-3 V2.3.2(2023-01)
Remark: /

The above equipment has been tested by Guangdong KEYS Testing Technology Co., Ltd. and found compliance with the requirements in the technical standards mentioned above. The test results presented in this report only relate to the product/system tested. The Other similar equipment will not necessarily produce the same results due to production tolerance and measurement uncertainties.

Prepared by:

Linda Chen

Linda Chen / Engineer

Approved by:

Summer Xia
Summer Xia / Manager

Guangdong KEYS Testing Technology Co., Ltd.

ing 1, No.18, Shihuan Road, Dongcheng Subdistrict, Dongguan, Guangdong, China

Tel: +86-0769-89798319 <http://www.keys-lab.com> E-mail: info@keys-lab.com

This report is only responsible for the test results of the samples submitted for inspection, and is not responsible for the source of the samples submitted for inspection. This report shall not be altered, increased or deleted. Without written approval of KEYS, this test report shall not be copied except in full and published as advertisement.

Test Report

Report No.:RKEYS250314098

Date: Mar.27, 2025

Page 4 of 65

2. TEST SUMMARY

EMISSION			
Standard	Item	Result	Remarks
BS EN 55032:2015+A11:2020	Conducted emission (Mains Port)	PASS	Complied with limit
	Radiated emission	PASS	Complied with limit
BS EN IEC 61000-3-2:2019+A1:2021	Harmonic current emissions	PASS	Complied with limit
BS EN 61000-3-3:2013+A2:2021	Voltage fluctuations & flicker	PASS	Complied with limit

IMMUNITY			
Standard	Item	Result	Remarks
BS EN 61000-4-2:2009	ESD	PASS	Complied with the requirements
BS EN IEC 61000-4-3:2020	RS	PASS	Complied with the requirements
BS EN 61000-4-4:2012	EFT	PASS	Complied with the requirements
BS EN 61000-4-5:2014 +A1:2017	Surge	PASS	Complied with the requirements
BS EN IEC 61000-4-6:2023	CS	PASS	Complied with the requirements
BS EN 61000-4-8:2010	PFMF	PASS	Complied with the requirements
BS EN IEC 61000-4-11:2020	Voltage dips & voltage variations	PASS	Complied with the requirements

Note: 1) The test result verdict is decided by the limit of test standard

2) The information of measurement uncertainty is available upon the customer's request.

Test Report

Report No.:RKEYS250314098

Date: Mar.27, 2025

Page 5 of 65

3. TEST SITE

3.1. TEST FACILITY

Guangdong KEYS Testing Technology Co., Ltd.

Address:Building 1, No.18, Shihuan Road, Dongcheng Subdistrict, Dongguan, Guangdong, China

3.2. MEASUREMENT UNCERTAINTY

Parameter	Uncertainty
Temperature	$\pm 1^{\circ}\text{C}$
Humidity	$\pm 5\%$
DC and Low Frequency Voltages	$\pm 3\%$
Conducted Emission(150KHz-30MHz)	$\pm 3.60\text{dB}$
Radiated Emission(30MHz-1GHz)	$\pm 4.76\text{dB}$
Radiated Emission (1GHz-18GHz)	$\pm 4.44\text{dB}$

Note 1: This uncertainty represents an expanded uncertainty expressed at approximately the 95% confidence level using a coverage factor of $k=2$.

3.3. LIST OF TEST AND MEASUREMENT INSTRUMENTS

3.3.1. For conducted emission at the mains terminals test

Name of Equipment	Manufacturer	Model	Serial No.	Calibration Due
EMI Test Receiver	Rohde&Schwarz	ESCI7	KEYS-E-005	July 2, 2025
Pulse limiter	Rohde&Schwarz	ESH3-Z2	KEYS-E-003	July 2, 2025
LISN impedance network TWO-LINE V-WORK	Rohde&Schwarz	ENV216	KEYS-E-004	July 2, 2025
Screened room	AUDIX	6*3*3	KEYS-E-001	July 23, 2025

Test Report

Report No.:RKEYS250314098

Date: Mar.27, 2025

Page 6 of 65

3.3.2. For radiated emission test (30MHz-1GHz)

Name of Equipment	Manufacturer	Model	Serial No.	Calibration Due
EMI Test Receiver	Rohde&Schwarz	ESCI7	KEYS-E-005	July 2, 2025
Composite antenna	Schwarzbeck	VULB9168	KEYS-E-013	July 9,2025
Preamplifier	AUDIX	EM330	KEYS-E-014	July 2, 2025
3m standard semi-anechoic chamber	AUDIX	9*6*6	KEYS-E-002	July 23, 2025

3.3.3. For radiated emission test (1GHz above)

Name of Equipment	Manufacturer	Model	Serial No.	Calibration Due
EMI Test Receiver	Rohde&Schwarz	ESCI7	KEYS-E-005	July 2, 2025
Multiple aerial	Schwarzbeck	9120D	KEYS-E-012	July 9, 2025
PreNight Stand	AUDIX	EM01G18G	KEYS-E-015	July 2, 2025
3m standard semi-anechoic chamber	AUDIX	9*6*6	KEYS-E-002	July 23, 2025

3.3.4. For harmonic current emissions and voltage fluctuations/flicker test

Name of Equipment	Manufacturer	Model	Serial No.	Calibration Due
Harmonics / Flicker Test System	DCUU INSTRUMENT CO., LTD.	KDF-11005G	KEYS-E-017	July 2, 2025
AC Power Source	DCUU INSTRUMENT CO., LTD.	BADT002-11	KEYS-E-025	Aug.23,2025

Test Report

Report No.:RKEYS250314098

Date: Mar.27, 2025

Page 7 of 65

3.3.5. For electrostatic discharge immunity test

Name of Equipment	Manufacturer	Model	Serial No.	Calibration Due
ESD Generator	Shanghai Lingshi Electronics Co., LTD	ESD-203A	KEYS-E-023	July 2, 2025

3.3.6. For radio frequency electromagnetic field immunity (R/S) test (DQT)

Name of Equipment	Manufacturer	Model	Serial No.	Calibration Due
Signal Generator	Agilent	N517113-50B	KEYS-EE-038	Sep. 17, 2025
Night Stand	A&R	150W1000M3	KEYS-EE-039	Sep. 17, 2025
Night Stand	A&R	50SIG6M2	KEYS-EE-040	Sep. 17, 2025
Antenna	SCHWARZBECK	STLP9149	KEYS-EE-046	Sep. 17, 2025
Isotropic Field Probe	A&R	FL7006	KEYS-EE-049	Sep. 17, 2025
Log-periodic Antenna	SCHWARZBECK	STLP 9128E	KEYS-EE-042	Sep. 17, 2025

3.3.7. For electrical fast transient/burst immunity test

Name of Equipment	Manufacturer	Model	Serial No.	Calibration Due
EFT Tester	HTEC	HEFT 51	KEYS-EE-051	Sep. 17, 2025
EFT Coupling Clamp	HTEC	HEFT 51-C	KEYS-EE-053	Sep. 17, 2025

3.3.8. For surge immunity test

Name of Equipment	Manufacturer	Model	Serial No.	Calibration Due
Lightning surge generator	Shanghai Prima Electronics Co., LTD	SUG61005TB-2216	KEYS-E-030	July 2, 2025

Test Report

Report No.:RKEYS250314098

Date: Mar.27, 2025

Page 8 of 65

3.3.9. For injected currents susceptibility test

Name of Equipment	Manufacturer	Model	Serial No.	Calibration Due
C/S Test System	SCHLODER	CDG-6000-25	KEYS-EE-056	Sep. 17, 2025
Coupling Decoupling Network	SCHLODER	CDN-M2+3	KEYS-EE-059	Sep. 17, 2025
Electromagnetic Injection Clamp	Luthi	EM101	KEYS-EE-066	Sep. 17, 2025

3.3.10. For power frequency magnetic field immunity test

Name of Equipment	Manufacturer	Model	Serial No.	Calibration Due
Magnetic Field Tester	HTEC	HPFMF	KEYS-EE-067	Sep. 17, 2025

3.3.11. For voltage dips and short interruptions immunity test

Name of Equipment	Manufacturer	Model	Serial No.	Calibration Due
Dips Tester	HTEC	HPFS	KEYS-EE-078	Sep. 17, 2025

Test Report

Report No.:RKEYS250314098

Date: Mar.27, 2025

Page 9 of 65

4. EUT DESCRIPTION

Product	Night Stand
Model	YS-02NS011A
RF Specification	2.4G
Supplied Voltage	Rated input:250V~/50Hz/16A/Max3680W/230V~ USB Ouput:5.0Vd.c.2.1A.10.5W Max

I/O PORT

I/O PORT TYPES	Q'TY	TESTED WITH
AC Port	1	<input checked="" type="checkbox"/>
DC Port	1	<input type="checkbox"/>

Models Difference

All series models are identical, except for model name difference for trading purpose.

Test Report

Report No.:RKEYS250314098

Date: Mar.27, 2025

Page 10 of 65

5. TEST METHODOLOGY

5.1. TEST MODE

The EUT was tested together with the thereafter additional components, and a configuration, which produced the worst emission levels, was selected and recorded in this report.

Test Mode 1	EUT +2.4G Link
Test Mode 2	EUT + Working

The following test mode(s) were assessed.

	Test Items	Test Mode
Emission	Conducted Emission	Mode 1
	Radiated Emission	Mode 1
	Radiated Emission above 1HGz	Mode 2
	Harmonic current emissions	All mode
	Voltage fluctuations & flicker	All mode
Immunity	ESD	All mode
	RS	All mode
	EFT	All mode
	Surge	All mode
	C/S	All mode
	M/S	All mode
	Dips	All mode

Note:Only the worse mode was record in this report.

5.2. EUT SYSTEM OPERATION

1. Set up EUT with the support equipment.
2. Make sure the EUT work normally during the test.

Test Report

Report No.:RKEYS250314098

Date: Mar.27, 2025

Page 11 of 65

6. SETUP OF EQUIPMENT UNDER TEST

6.1. DESCRIPTION OF SUPPORT UNITS

The EUT has been tested as an independent unit together with other necessary accessories or support units. The following support units or accessories were used to form a representative test configuration during the tests.

No.	Equipment	Model	Serial No.	FCC ID	Trade Name	Data Cable	Power Cord
1.	N/A	N/A	N/A	N/A	N/A	N/A	N/A

Note: 1) All the equipment/cables were placed in the worst-case configuration to maximize the emission during the test.

2) Grounding was established in accordance with the manufacturer's requirements and conditions for the intended use.

6.2. CONFIGURATION OF SYSTEM UNDER TEST

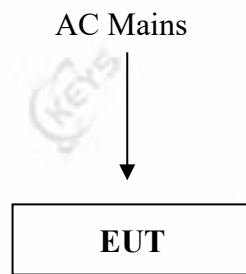

(EUT: Night Stand)

Test Report

7. EMISSION TEST

7.1. CONDUCTED EMISSION MEASUREMENT

7.1.1. LIMIT

FREQUENCY (MHz)	Class A		Class B	
	Quasi-peak dB(μ V)	Average dB(μ V)	Quasi-peak dB(μ V)	Average dB(μ V)
0.15 - 0.5	79	66	66-56	56-46
0.5 - 5.0	73	60	56	46
5.0 - 30.0	73	60	60	50

Note: 1) The lower limit shall apply at the transition frequencies.

2) The limit decreases in line with the logarithm of the frequency in the range of 0.15 MHz to 0.5 MHz

7.1.2. TEST PROCEDURE

The EUT and Support equipment, if needed, was set up as per the test configuration to simulate typical usage per the user's manual. When the EUT is a tabletop system, a wooden table with a height of 0.8 meters is used and is placed on the ground plane. When the EUT is floor standing equipment, it is placed on the ground plane, which has a 3-12 mm non-conductive covering to insulate the EUT from the ground plane. The EUT should be 0.8 m apart from the AMN, where the mains cable supplied by the manufacturer is longer than 0.8 m, the excess should be folded at the centre into a bundle no longer than 0.4 m, Details please refer to test setup photography.

The Receiver scanned from 9 kHz to 30 MHz for emissions in each of the test modes.

During the above scans, the emissions were maximized by cable manipulation.

A scanning was taken on the power lines, Line and neutral, recording at least six highest emissions. Emission frequency and amplitude were recorded into a computer in which correction factors were used to calculate the emission level and compare reading to the applicable limit. The test data of the worst-case condition(s) was recorded.

Test Report

Report No.:RKEYS250314098

Date: Mar.27, 2025

Page 13 of 65

7.1.3. TEST SETUP

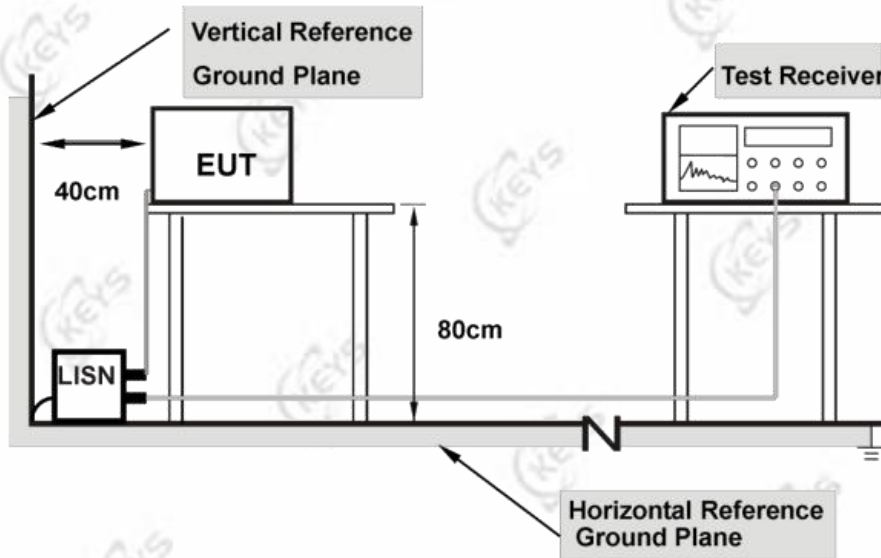

Note: 1.Support units were connected to second LISN.

2.Both of LISNs(AMN) are 80 cm from EUT and at least 80 from other units and other metal planes

7.1.4. TEST RESULT

Product name	Night Stand	Tested By	Joy Jiang
Model	YS-02NS011A	Detector Function	Quasi-peak/AV
Test Mode	Mode 1	6 dB Bandwidth	9 kHz
Environmental Conditions	24.3°C,53% RH, 101.1 kPa	Test Result	Pass

Note:

L = Line Line, N = Neutral Line

Freq. = Emission frequency in MHz

Reading level (dBμV) = Receiver reading

Corr. Factor (dB) = attenuator + Cable loss

Level (dBμV) = Reading level (dBμV) + Corr. Factor (dB)

Limit (dBμV) = Limit stated in standard

Over Limit (dB) = Level (dBμV) – Limit (dBμV)

QP = Quasi-Peak

AV = Average

Guangdong KEYS Testing Technology Co., Ltd.

Address: Building 1, No.18, Shihuan Road, Dongcheng Subdistrict, Dongguan, Guangdong, China

Tel: +86-0769-89798319 <http://www.keys-lab.com> E-mail: info@keys-lab.com

This report is only responsible for the test results of the samples submitted for inspection, and is not responsible for the source of the samples submitted for inspection. This report shall not be altered, increased or deleted. Without written approval of KEYS, this test report shall not be copied except in full and published as advertisement.

Test Report

Report No.:RKEYS250314098

Date: Mar.27, 2025

Page 14 of 65

Please refer to the following diagram:

Line:

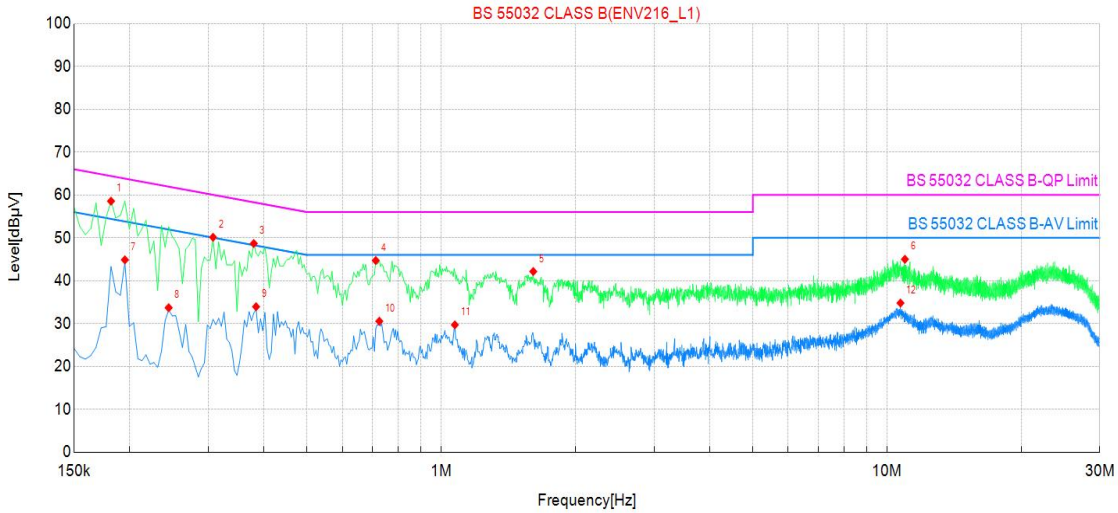

Suspected Data List									
NO.	Frequency [MHz]	Reading [dBµV]	Level [dBµV]	Factor [dB]	Limit [dBµV]	Margin [dB]	Phase	Detector	Verdict
1	0.181500	38.56	58.56	20.00	64.58	6.02	ENV21	QP	PASS
2	0.307500	30.13	50.13	20.00	60.13	10.00	ENV21	QP	PASS
3	0.379500	28.67	48.67	20.00	58.33	9.66	ENV21	QP	PASS
4	0.712500	24.70	44.70	20.00	56.00	11.30	ENV21	QP	PASS
5	1.608000	22.15	42.15	20.00	56.00	13.85	ENV21	QP	PASS
6	10.968000	24.99	44.99	20.00	60.00	15.01	ENV21	QP	PASS
7	0.195000	24.86	44.86	20.00	53.95	9.09	ENV21	AV	PASS
8	0.244500	13.69	33.69	20.00	52.06	18.37	ENV21	AV	PASS
9	0.384000	13.92	33.92	20.00	48.26	14.34	ENV21	AV	PASS
10	0.726000	10.54	30.54	20.00	46.00	15.46	ENV21	AV	PASS
11	1.072500	9.70	29.70	20.00	46.00	16.30	ENV21	AV	PASS
12	10.720500	14.78	34.78	20.00	50.00	15.22	ENV21	AV	PASS

Note:(1)Level=Reading+Factor

(2)Margin=Limit-Level

Test Report

Report No.:RKEYS250314098

Date: Mar.27, 2025

Page 15 of 65

Neutral:

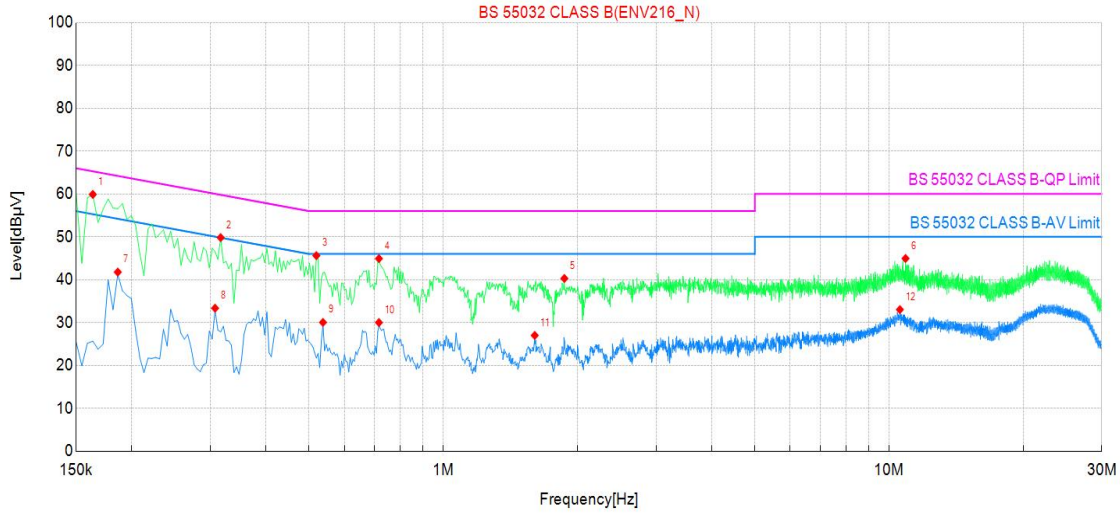

Suspected Data List									
NO.	Frequency [MHz]	Reading [dBµV]	Level [dBµV]	Factor [dB]	Limit [dBµV]	Margin [dB]	Phase	Detector	Verdict
1	0.163500	39.89	59.89	20.00	65.44	5.55	ENV21	QP	PASS
2	0.316500	29.82	49.82	20.00	59.85	10.03	ENV21	QP	PASS
3	0.519000	25.61	45.61	20.00	56.00	10.39	ENV21	QP	PASS
4	0.717000	24.92	44.92	20.00	56.00	11.08	ENV21	QP	PASS
5	1.869000	20.29	40.29	20.00	56.00	15.71	ENV21	QP	PASS
6	10.891500	24.95	44.95	20.00	60.00	15.05	ENV21	QP	PASS
7	0.186000	21.77	41.77	20.00	54.26	12.49	ENV21	AV	PASS
8	0.307500	13.35	33.35	20.00	50.13	16.78	ENV21	AV	PASS
9	0.537000	10.03	30.03	20.00	46.00	15.97	ENV21	AV	PASS
10	0.717000	10.00	30.00	20.00	46.00	16.00	ENV21	AV	PASS
11	1.603500	6.99	26.99	20.00	46.00	19.01	ENV21	AV	PASS
12	10.576500	13.02	33.02	20.00	50.00	16.98	ENV21	AV	PASS

Note:(1)Level=Reading+Factor
(2)Margin=Limit-Level

Test Report

Report No.:RKEYS250314098

Date: Mar.27, 2025

Page 16 of 65

7.2. RADIATED EMISSION MEASUREMENT

7.2.1. LIMITS

FREQUENCY (MHz)	Distance m	Quasi Peak dB(μ V/m)
30~230	3	40
230~1000	3	47

Note: 1) The lower limit shall apply at the transition frequencies.

2) Emission level (dB μ V/m) = 20 log Emission level (μ V/m).

7.2.2. TEST PROCEDURE

- The EUT was placed on the top of an insulating table 0.8 meters above the ground at a semi-anechoic chamber. The table was rotated 360 degrees to determine the position of the highest radiation.
- The EUT was set 3 meters away from the interference-receiving antenna, which was mounted on the top of a variable-height antenna tower.
- The antenna is a broadband antenna, and its height is varied from 1 to 4 meter above the ground to determine the maximum value of the field strength. Both horizontal and vertical polarization of the antenna are set to make the measurement.
- For each suspected emission, the EUT was arranged to its worst case and then the antenna was tuned to the heights from 1 to 4 meters and the ratable table was turned from 0 degrees to 360 degrees to find the maximum reading.
- The test-receiver system was set to Peak Detector Function and Specified Bandwidth with Maximum Hold Mode when the test frequency is below 1GHz.

Note:

1.The resolution bandwidth of test receiver/spectrum analyzer is 120khz for quasi-peak detection(QP) at frequency below 1GHz.

2.Emission level(dB μ V/m)=Raw Value(dB μ V)+Correction Factor(dB/m)

3.Correction Factor(dB/m)=Antenna Factor(dB/m)+ Correction Factor(dB)(if the raw value not contains the amplifier);

4. Correction Factor(dB/m)=Antenna Factor(dB/m)+ Correction Factor(dB)-Amplifer Gain(dB)(if the raw value contains the amplifier).

5.Margin value=Emission level-Limit value.

Test Report

7.2.3. TEST SETUP

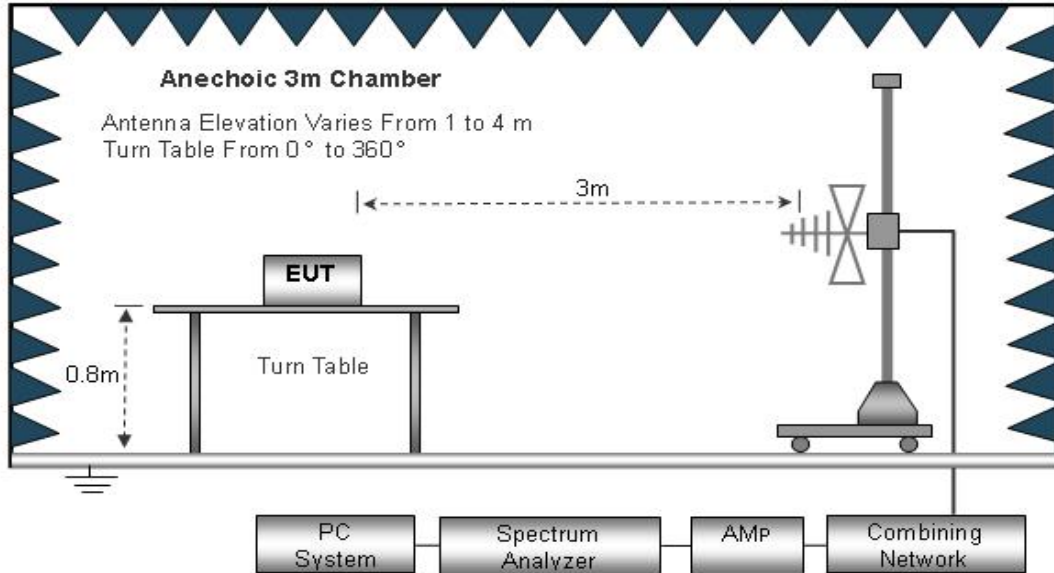

Note: For the actual test configuration, please refer to the related item – Photographs of the Test Configuration

Test distance define

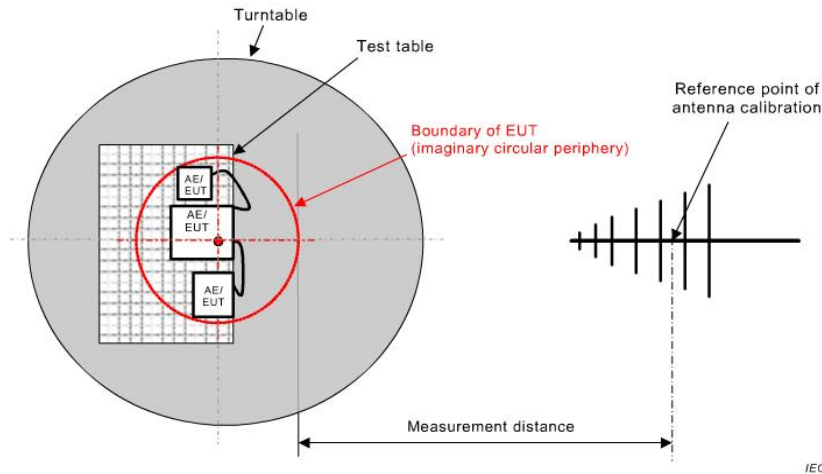

Figure C.1 – Measurement distance

Test Report

Report No.:RKEYS250314098

Date: Mar.27, 2025

Page 18 of 65

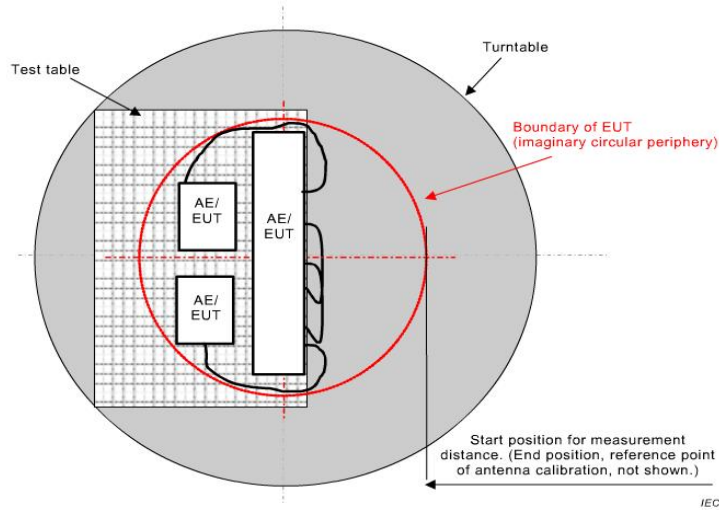

7.2.4. TEST RESULT

Product name	Night Stand	Tested By	Joy Jiang
Model	YS-02NS011A	Detector Function	Quasi-peak
Test Mode	Mode 1	RBW	120kHz
Environmental Conditions	24.3°C, 52% RH, 101.1 kPa	Test Result	Pass

Test Report

Report No.:RKEYS250314098

Date: Mar.27, 2025

Page 19 of 65

Please refer to the following diagram:

Vertical:

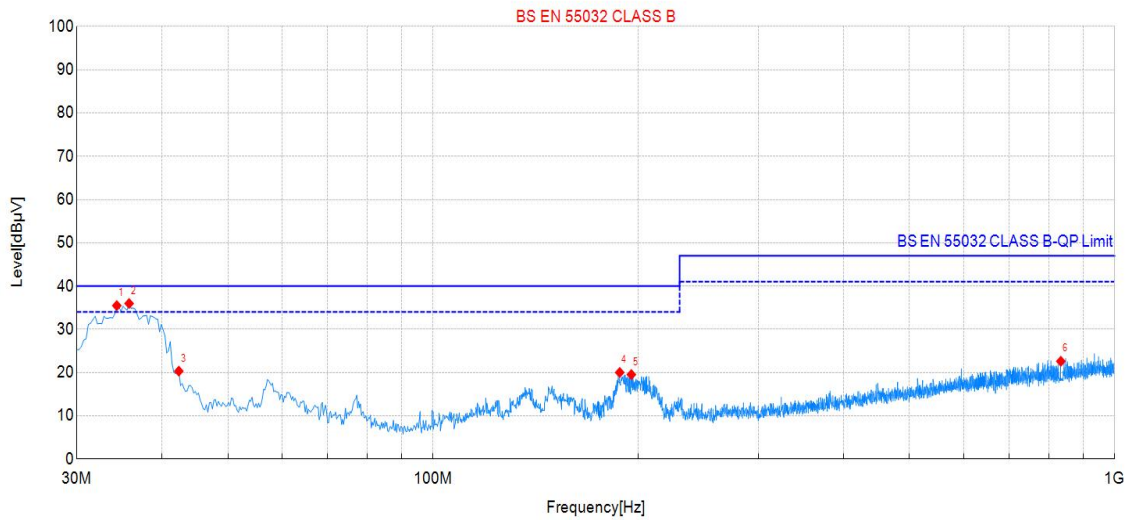

Suspected Data List										
NO.	Frequency [MHz]	Reading [dBuV]	Level [dBuV]	Factor [dB/m]	Margin [dB]	Height [cm]	Angle [°]	Det	Pol	Verdict
1	34.37	55.1	35.48	-19.65	4.52	100	280	QP	Verti	PASS
2	35.82	55.4	35.97	-19.44	4.03	100	240	QP	Verti	PASS
3	42.37	39.3	20.33	-18.97	19.67	100	30	QP	Verti	PASS
4	187.87	42.0	20.02	-22.00	19.98	100	120	QP	Verti	PASS
5	195.39	42.0	19.53	-22.49	20.47	100	50	QP	Verti	PASS
6	833.65	32.4	22.61	-9.82	24.39	100	270	QP	Verti	PASS

Note:(1)Level=Reading+Factor
(2)Margin=Limit-Level

Test Report

Report No.:RKEYS250314098

Date: Mar.27, 2025

Page 20 of 65

Please refer to the following diagram:

Horizontal::

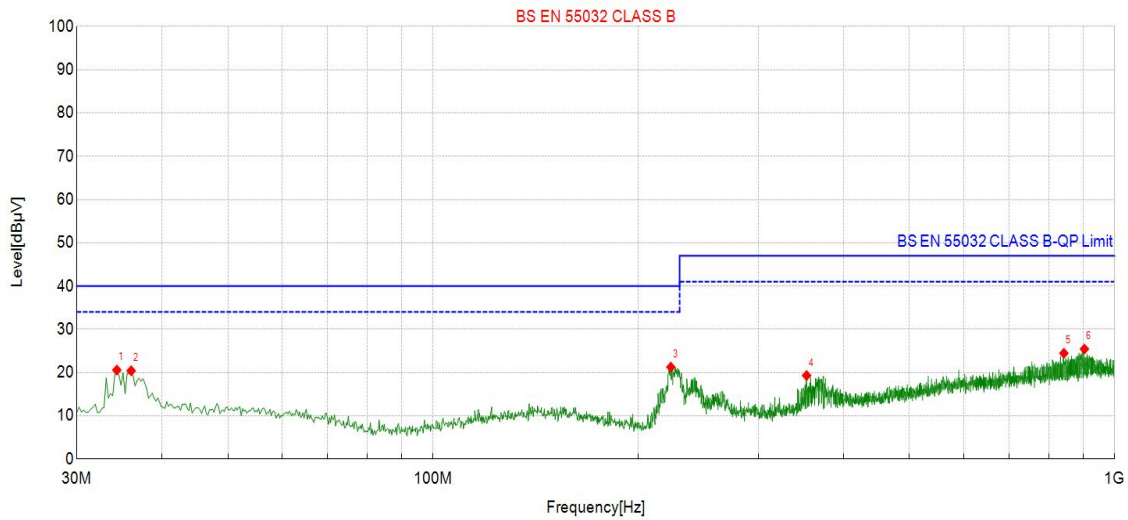

Suspected Data List										
NO.	Frequency [MHz]	Reading [dBµV]	Level [dBµV]	Factor [dB/m]	Margin [dB]	Height [cm]	Angle [°]	Det	Pol	Verdict
1	34.37	40.2	20.57	-19.65	19.43	100	250	QP	Hori	PASS
2	36.06	39.8	20.41	-19.40	19.59	100	230	QP	Hori	PASS
3	223.27	43.1	21.26	-21.88	18.74	100	340	QP	Hori	PASS
4	353.25	37.2	19.32	-17.87	27.68	100	210	QP	Hori	PASS
5	842.38	34.2	24.46	-9.75	22.54	100	110	QP	Hori	PASS
6	902.76	34.7	25.45	-9.21	21.55	100	260	QP	Hori	PASS

Note:(1)Level=Reading+Factor

(2)Margin=Limit-Level

Test Report

7.3. RADIATED EMISSION MEASUREMENT(ABOVE 1GHz)

7.3.1. LIMITS

FREQUENCY (MHz)	Distance m	Peak dB(μ V/m)	Average dB(μ V/m)
1000~3000	3	50	54
3000~ 6000	3	70	74

Note: 1) The lower limit shall apply at the transition frequencies.

2) Emission level (dB μ V/m) = 20 log Emission level (μ V/m).

7.3.2. TEST PROCEDURE

- The EUT was placed on the top of an insulating table 0.8 meters above the ground at a semi-anechoic chamber. The table was rotated 360 degrees to determine the position of the highest radiation.
- The EUT was set 3 meters away from the interference-receiving antenna, which was mounted on the top of a variable-height antenna tower.
- The height of antenna is varied from 1 to 4 meter above the ground ,the height of adjustment depends on the EUT height and the antenna 3dB bandwidth both,to determine the maximum value of the field strength. Both horizontal and vertical polarization of the antenna are set to make the measurement.The boresight should be used during the test above 1GHz.
- For each suspected emission, the EUT was arranged to its worst case and then the antenna was tuned to the heights from 1 to 4 meters and the ratable table was turned from 0 degrees to 360 degrees to find the maximum reading.
- The test-receiver system was set to Peak Detector Function and Specified Bandwidth with Maximum Hold Mode when the test frequency is above1GHz.

Test Report

Report No.:RKEYS250314098

Date: Mar.27, 2025

Page 22 of 65

7.3.3. TEST SETUP

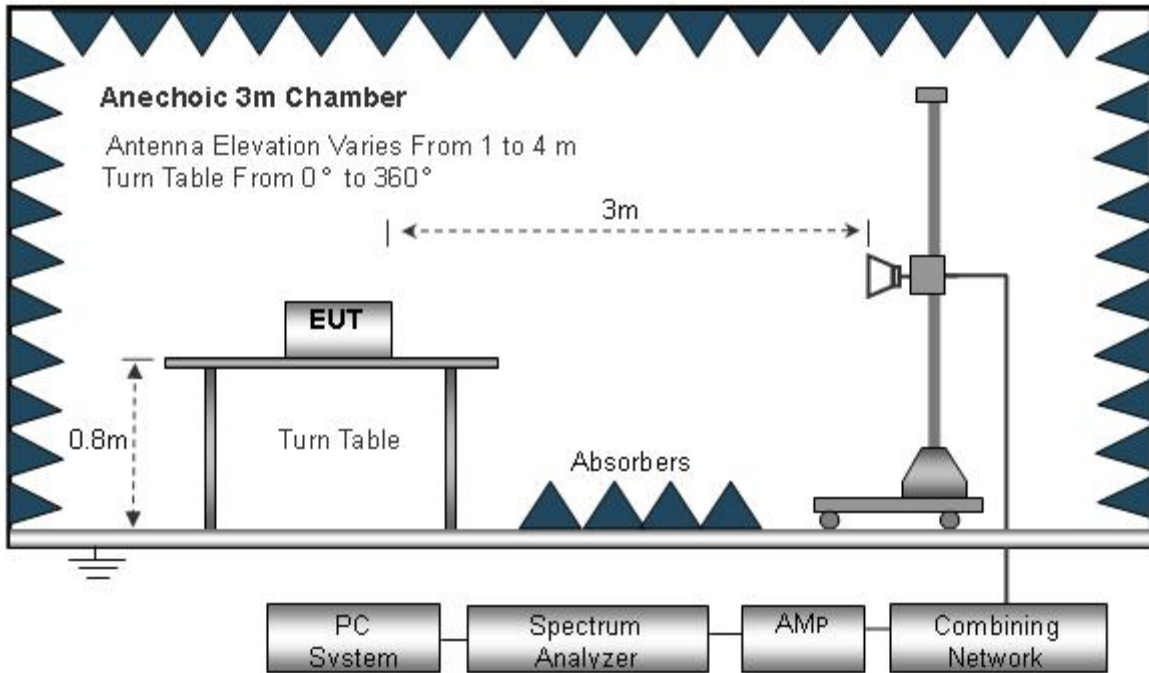

Note: For the actual test configuration, please refer to the related item – Photographs of the Test Configuration

7.3.4. TEST RESULT

Product name	Night Stand	Tested By	Joy Jiang
Model	YS-02NS011A	Detector Function	Peak/AV
Test Mode	Mode 2	RBW	1MHz
Environmental Conditions	24.3°C, 52% RH, 101.1 kPa	Test Result	Pass

Test Report

Report No.:RKEYS250314098

Date: Mar.27, 2025

Page 23 of 65

Please refer to the following diagram:

Vertical:

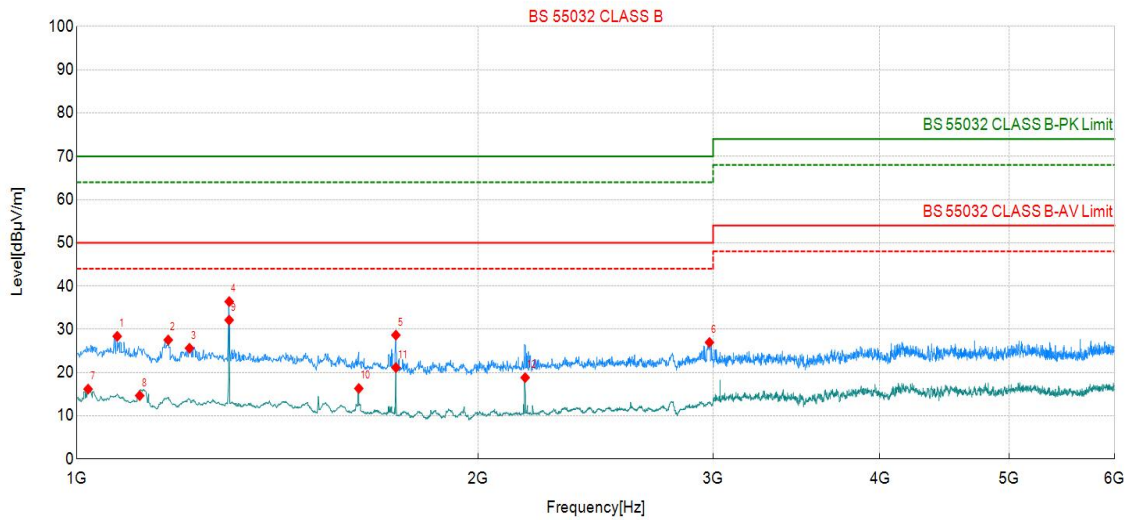

Suspected Data List										
NO.	Frequency [MHz]	Reading [dBμV]	Factor [dB/m]	Limit [dBμV/m]	Margin [dB]	Height [cm]	Angle [°]	Det	Pol	Verdict
1	1072.50	60.9	-32.52	70.00	41.62	100	4	QP	Verti	PASS
2	1171.25	60.6	-33.03	70.00	42.46	100	177	QP	Verti	PASS
3	1215.00	58.9	-33.25	70.00	44.37	100	208	QP	Verti	PASS
4	1301.25	70.1	-33.69	70.00	33.60	100	104	QP	Verti	PASS
5	1735.00	64.6	-35.90	70.00	41.34	100	269	QP	Verti	PASS
6	2981.25	62.5	-35.50	70.00	43.03	100	341	QP	Verti	PASS
7	1020.00	48.4	-32.25	50.00	33.83	100	310	AV	Verti	PASS
8	1115.00	47.4	-32.74	50.00	35.33	100	187	AV	Verti	PASS
9	1301.25	65.8	-33.69	50.00	17.87	100	51	AV	Verti	PASS
10	1627.50	51.7	-35.35	50.00	33.68	100	74	AV	Verti	PASS
11	1735.00	57.1	-35.90	50.00	28.85	100	269	AV	Verti	PASS
12	2168.75	55.8	-36.95	50.00	31.17	100	94	AV	Verti	PASS

Note:(1)Level=Reading+Factor

(2)Margin=Limit-Level

Test Report

Report No.:RKEYS250314098

Date: Mar.27, 2025

Page 24 of 65

Please refer to the following diagram:

Horizontal::

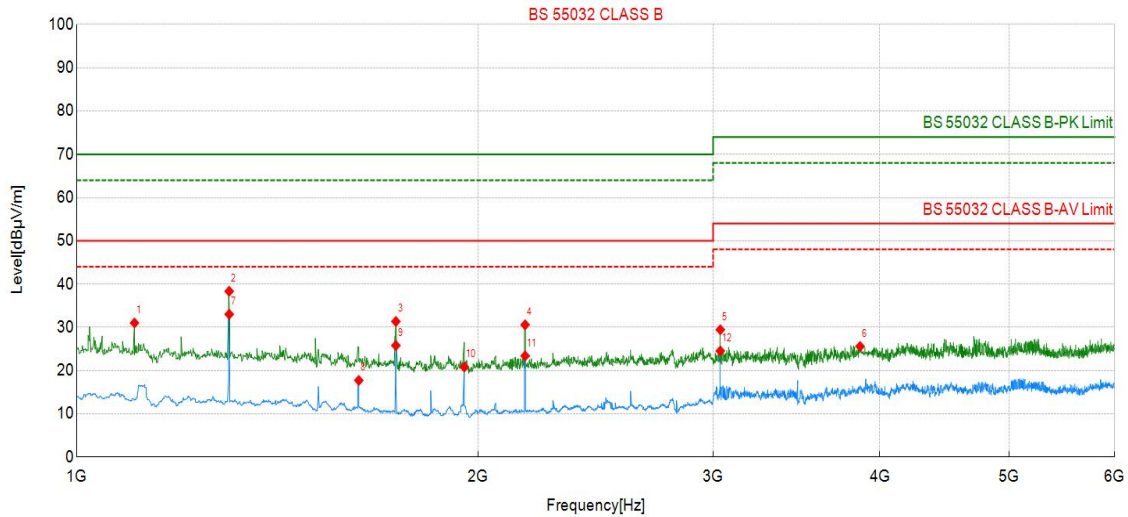

Suspected Data List										
NO.	Frequency [MHz]	Reading [dBuV]	Factor [dB/m]	Limit [dBuV/m]	Margin [dB]	Height [cm]	Angle [°]	Det	Pol	Verdict
1	1105.00	63.7	-32.69	70.00	38.50	100	122	QP	Hori	PASS
2	1301.25	72.0	-33.69	70.00	31.16	100	309	QP	Hori	PASS
3	1735.00	67.3	-35.90	70.00	38.15	100	40	QP	Hori	PASS
4	2168.75	67.5	-36.95	70.00	38.92	100	289	QP	Hori	PASS
5	3037.50	64.9	-35.45	74.00	44.06	100	330	QP	Hori	PASS
6	3866.25	60.6	-35.04	74.00	47.92	100	204	QP	Hori	PASS
7	1301.25	66.7	-33.69	50.00	16.49	100	81	AV	Hori	PASS
8	1627.50	53.1	-35.35	50.00	31.77	100	30	AV	Hori	PASS
9	1735.00	61.7	-35.90	50.00	24.21	100	40	AV	Hori	PASS
10	1952.50	57.8	-37.01	50.00	29.18	100	330	AV	Hori	PASS
11	2168.75	60.3	-36.95	50.00	26.11	100	289	AV	Hori	PASS
12	3037.50	60.0	-35.45	54.00	29.97	100	330	AV	Hori	PASS

Note:(1)Level=Reading+Factor

(2)Margin=Limit-Level

Test Report

Report No.:RKEYS250314098

Date: Mar.27, 2025

Page 25 of 65

7.4. HARMONICS CURRENT MEASUREMENT

7.4.1. LIMITS OF HARMONICS CURRENT MEASUREMENT

Limit for Class A equipment		Limit for Class D equipment		
Harmonics Order N	Max. permissible harmonics current A	Harmonics Order n	Max. permissible harmonics current per watt mA/W	Max. permissible harmonics current A
Odd harmonics		Odd Harmonics only		
3	2.30	3	3.4	2.30
5	1.14	5	1.9	1.14
7	0.77	7	1.0	0.77
9	0.40	9	0.5	0.40
11	0.33	11	0.35	0.33
13	0.21	13	0.30	0.21
$15 \leq n \leq 39$	$0.15 \times (15/n)$	$15 \leq n \leq 39$ (odd harmonics only)	$3.85/n$	$0.15 \times (15/n)$
Even harmonics				
2	1.08			
4	0.43			
6	0.30			
$8 \leq n \leq 40$	$0.23 \times 8/n$			

Limit for Class C equipment	
Harmonics Order n	Max. permissible harmonics current expressed as a percentage of the input current at the fundamental frequency A
2	2
3	$30 \times F$
5	10
7	7
9	5
$11 \leq n < 39$ (odd harmonics only)	3

F is the circuit power factor

Test Report

Report No.:RKEYS250314098

Date: Mar.27, 2025

Page 26 of 65

Note: Class A, B, C and D are classified according to item 7.4.2.of this report

7.4.2. TEST PROCEDURE

The EUT was placed on the top of a wooden table 0.8 meters above the ground and operated to produce the maximum harmonic. The classification of EUT is according to section 5 of EN 61000-3-2.

The EUT is classified as follows:

Class A:

Balanced three-phase equipment, Household appliances excluding equipment as Class D, Tools excluding portable tools, Dimmers for incandescent lamps, audio equipment, equipment not specified in one of the three other classes.

Class B:

Portable tools; Arc welding equipment which is not professional equipment.

Class C:

Lighting equipment

Class D:

Equipment having a specified power less than or equal to 600 W of the following types: Personal computers and personal computer monitors and television receivers.

The correspondent test program of test instrument to measure the current harmonics emanated from EUT is chosen. The measure time shall be not less than the time necessary for the EUT to be exercised.

7.4.3. TEST SETUP

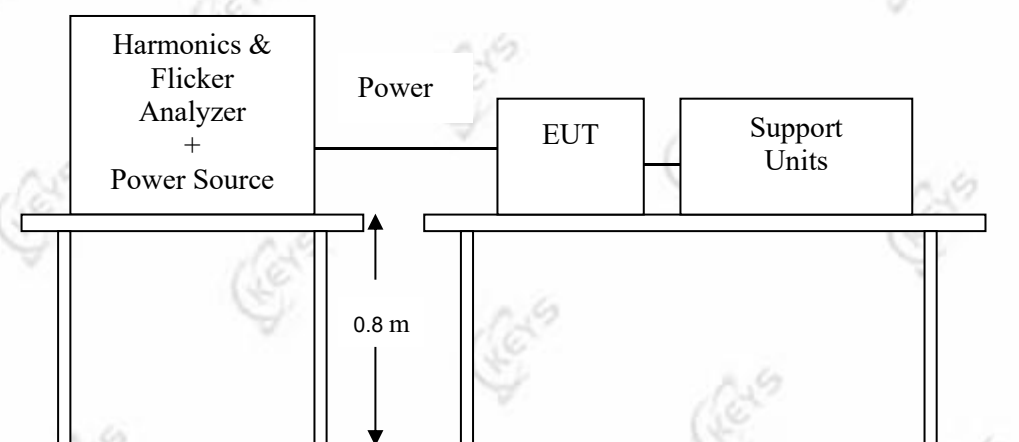

For the actual test configuration, please refer to the related item – Photographs of the Test Configuration.

Test Report

Report No.:RKEYS250314098

Date: Mar.27, 2025

Page 27 of 65

7.4.4. TEST RESULT

Product	Night Stand	Tested by	Brian
Model	YS-02NS011A	Limits	Class <input type="checkbox"/> A <input type="checkbox"/> B <input checked="" type="checkbox"/> C <input type="checkbox"/> D
Test Mode	All mode	Observation Period (Tp)	10 mins
Environmental Conditions	24.3°C, 54% RH, 101.1 kPa	Test Result	Pass

8. Note: 1) Limits classified according to item 7.4.2 of this report.

Test Report

Report No.:RKEYS250314098

Date: Mar.27, 2025

Page 28 of 65

Please refer to the following test data:

EUT: Night Stand	M/N: YS-02NS011A	Tested by: Brian
Test category: Class-C per Ed. 4.0 (2014) (European limits)		Test Margin: 100
Test date: 2025/03/20	Start time: 09:00:03	End time: 09:10:03
Test duration (min): 10	Data file name: H-000211.cts_data	

Comment: All mode

Customer:

Test Result: Pass **Source qualification: Normal**

Current & voltage waveforms

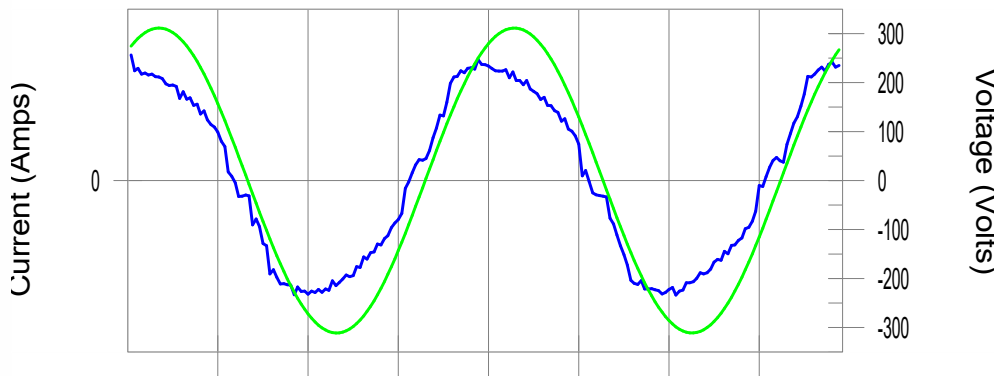

Harmonics and Class C limit line

European Limits

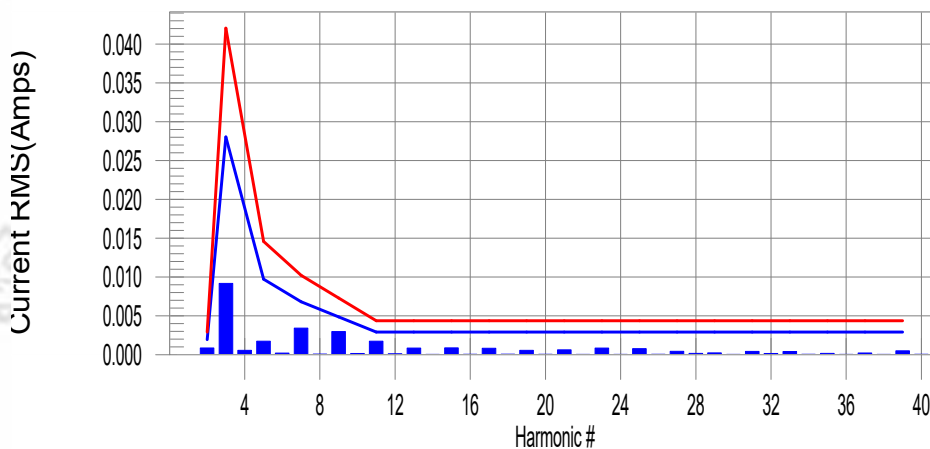

Test result: Pass **Worst harmonics H5-62.1% of 150% limit, H5-91.5% of 100% limit.**

Guangdong KEYS Testing Technology Co., Ltd.

Address: Building 1, No.18, Shihuan Road, Dongcheng Subdistrict, Dongguan, Guangdong, China
Tel: +86-0769-89798319 <http://www.keys-lab.com> E-mail: info@keys-lab.com

This report is only responsible for the test results of the samples submitted for inspection, and is not responsible for the source of the samples submitted for inspection. This report shall not be altered, increased or deleted. Without written approval of KEYS, this test report shall not be copied except in full and published as advertisement.

Test Report

Report No.: RKEYS250314098

Date: Mar.20, 2025

Page 29 of 65

Current Test Result Summary (Run time)

EUT: Night Stand M/N: YS-02NS011A Tested by: Brian
 Test category: Class-C per Ed. 4.0 (2014) (European limits) Test Margin: 100
 Test date: 2025/03/20 Start time: 09:00:03 End time: 09:10:03
 Test duration (min): 10 Data file name: H-000211.cts_data
 Comment: All mode
 Customer:

Test Result: Pass Source qualification: Normal
 THC(A): 0.035 I-THD(%): 16.7 POHC(A): 0.000 POHC Limit(A): 0.020

Highest parameter values during test:

V_RMS (Volts): 230.08 Frequency(Hz): 50.00
 I_Peak (Amps): 15.9986 I_RMS (Amps): 15.9973
 I_Fund (Amps): 15.9945 Crest Factor: 15.9981
 Power (Watts): 3680.03 Power Factor: 0.978

Harm#	Harms(avg)	100%Limit	%of Limit	Harms(max)	150%Limit	%of Limit	Status
2	0.001	0.002	N/A	0.001	0.003	N/A	Pass
3	0.009	0.028	32.7	0.010	0.042	23.7	Pass
4	0.001	0.000	N/A	0.001	0.000	N/A	Pass
5	0.002	0.010	N/A	0.002	0.015	N/A	Pass
6	0.000	0.000	N/A	0.000	0.000	N/A	Pass
7	0.003	0.007	N/A	0.004	0.010	N/A	Pass
8	0.000	0.000	N/A	0.000	0.000	N/A	Pass
9	0.003	0.005	N/A	0.003	0.007	N/A	Pass
10	0.000	0.000	N/A	0.000	0.000	N/A	Pass
11	0.002	0.003	N/A	0.002	0.004	N/A	Pass
12	0.000	0.000	N/A	0.000	0.000	N/A	Pass
13	0.001	0.003	N/A	0.001	0.004	N/A	Pass
14	0.000	0.000	N/A	0.000	0.000	N/A	Pass
15	0.001	0.003	N/A	0.001	0.004	N/A	Pass
16	0.000	0.000	N/A	0.000	0.000	N/A	Pass

Test Report

Report No.: RKEYS250314098

Date: Mar.20, 2025

Page 30 of 65

17	0.001	0.003	N/A	0.001	0.004	N/A	Pass
18	0.000	0.000	N/A	0.000	0.000	N/A	Pass
19	0.001	0.003	N/A	0.001	0.004	N/A	Pass
20	0.000	0.000	N/A	0.000	0.000	N/A	Pass
21	0.001	0.003	N/A	0.001	0.004	N/A	Pass
22	0.000	0.000	N/A	0.000	0.000	N/A	Pass
23	0.001	0.003	N/A	0.001	0.004	N/A	Pass
24	0.000	0.000	N/A	0.000	0.000	N/A	Pass
25	0.001	0.003	N/A	0.001	0.004	N/A	Pass
26	0.000	0.000	N/A	0.000	0.000	N/A	Pass
27	0.000	0.003	N/A	0.000	0.004	N/A	Pass
28	0.000	0.000	N/A	0.000	0.000	N/A	Pass
29	0.000	0.003	N/A	0.000	0.004	N/A	Pass
30	0.000	0.000	N/A	0.000	0.000	N/A	Pass
31	0.000	0.003	N/A	0.000	0.004	N/A	Pass
32	0.000	0.000	N/A	0.000	0.000	N/A	Pass
33	0.000	0.003	N/A	0.000	0.004	N/A	Pass
34	0.000	0.000	N/A	0.000	0.000	N/A	Pass
35	0.000	0.003	N/A	0.000	0.004	N/A	Pass
36	0.000	0.000	N/A	0.000	0.000	N/A	Pass
37	0.000	0.003	N/A	0.000	0.004	N/A	Pass
38	0.000	0.000	N/A	0.000	0.000	N/A	Pass
39	0.000	0.003	N/A	0.001	0.004	N/A	Pass
40	0.000	0.000	N/A	0.000	0.000	N/A	Pass

Note: Dynamic limits were applied for this test. The highest harmonics values in the above table may not occur at the same window as the maximum harmonics/limit ratio.

Test Report

Report No.: RKEYS250314098

Date: Mar.20, 2025

Page 31 of 65

Voltage Source Verification Data (Run time)

EUT: Night Stand M/N: YS-02NS011A Tested by: Brian
Test category: Class-C per Ed. 4.0 (2014) (European limits) Test Margin: 100
Test date: 2025/03/20 Start time: 09:00:03 End time: 09:10:03
Test duration (min): 10 Data file name: H-000211.cts_data
Comment: All mode
Customer:
Test Result: Pass Source qualification: Normal

Highest parameter values during test:

V_RMS (Volts): 230.08 Frequency(Hz): 50.00
I_Peak (Amps): 15.9986 I_RMS (Amps): 15.9973
I_Fund (Amps): 15.9945 Crest Factor: 15.9981
Power (Watts): 3680.03 Power Factor: 0.978

Harm#	Harmonics	V-rms	Limit V-rms	% of Limit	Status
2		0.060	0.440	13.70	OK
3		0.320	1.981	16.13	OK
4		0.037	0.440	8.38	OK
5		0.027	0.881	3.10	OK
6		0.019	0.440	4.40	OK
7		0.025	0.660	3.86	OK
8		0.010	0.440	2.38	OK
9		0.011	0.440	2.52	OK
10		0.012	0.440	2.62	OK
11		0.019	0.220	8.55	OK
12		0.008	0.220	3.69	OK
13		0.011	0.220	4.87	OK
14		0.006	0.220	2.64	OK
15		0.012	0.220	5.34	OK
16		0.005	0.220	2.18	OK
17		0.006	0.220	2.63	OK
18		0.005	0.220	2.08	OK

Test Report

Report No.: RKEYS250314098

Date: Mar.20, 2025

Page 32 of 65

19	0.011	0.220	4.82	OK
20	0.011	0.220	5.06	OK
21	0.007	0.220	3.30	OK
22	0.003	0.220	1.50	OK
23	0.006	0.220	2.71	OK
24	0.003	0.220	1.35	OK
25	0.005	0.220	2.19	OK
26	0.003	0.220	1.40	OK
27	0.006	0.220	2.92	OK
28	0.004	0.220	1.64	OK
29	0.004	0.220	1.65	OK
30	0.002	0.220	1.01	OK
31	0.005	0.220	2.34	OK
32	0.003	0.220	1.46	OK
33	0.007	0.220	3.25	OK
34	0.003	0.220	1.41	OK
35	0.005	0.220	2.48	OK
36	0.002	0.220	1.06	OK
37	0.003	0.220	1.49	OK
38	0.003	0.220	1.28	OK
39	0.006	0.220	2.68	OK
40	0.010	0.220	4.33	OK

Test Report

Report No.: RKEYS250314098

Date: Mar.20, 2025

Page 33 of 65

7.5. VOLTAGE FLUCTUATION AND FLICKS MEASUREMENT

7.5.1. LIMITS OF VOLTAGE FLUCTUATION AND FLICKS MEASUREMENT

TEST ITEM	LIMIT	REMARK
P_{st}	1.0	P_{st} means short-term flicker indicator.
P_{lt}	0.65	P_{lt} means long-term flicker indicator.
T_{dt} (ms)	500	T_{dt} means maximum time that dt exceeds 3 %.
d_{max} (%)	4/6/7 %	d_{max} means maximum relative voltage change.
dc (%)	3.3 %	dc means relative steady-state voltage change

7.5.2. TEST PROCEDURE

The EUT was placed on the top of a wooden table 0.8 meters above the ground and operated to produce the most unfavorable sequence of voltage changes under lighting operating conditions.

During the flick measurement, the measure time shall include that part of whole operation cycle in which the EUT produce the most unfavorable sequence of voltage changes. The observation period for short-term flicker indicator is 10 minutes and the observation period for long-term flicker indicator is 2 hours.

7.5.3. TEST SETUP

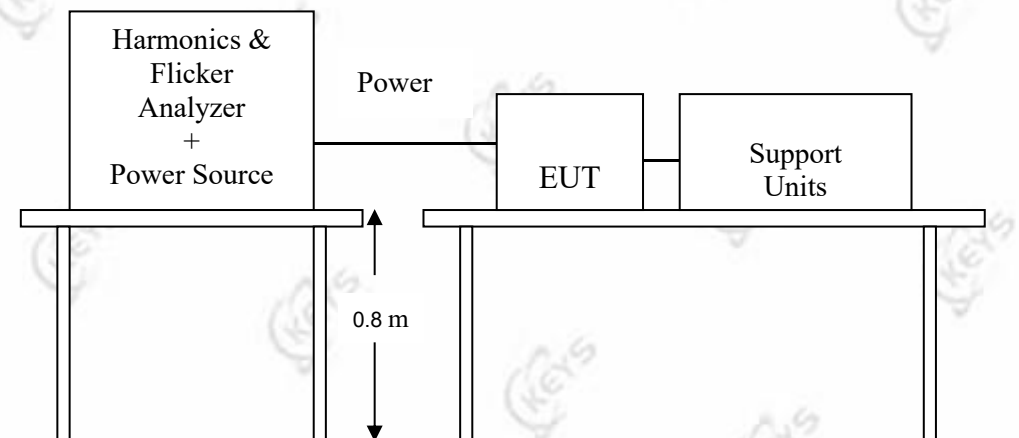

For the actual test configuration, please refer to the related item – Photographs of the Test Configuration.

Test Report

Report No.: RKEYS250314098

Date: Mar.20, 2025

Page 34 of 65

7.5.4. TEST RESULT

Product	Night Stand	Tested by	Joy Jiang
Model	YS-02NS011A	Observation Period (Tp)	10 mins
Test Mode	All mode	Test Result	Pass
Environmental Conditions	24.3°C,53% RH, 101.1 kPa		

Test Report

Report No.: RKEYS250314098

Date: Mar.20, 2025

Page 35 of 65

Please refer to the following test data:

EUT: Night Stand M/N: SE-2018 Tested by: Joy Jiang

Test category: All parameters (European limits) Test Margin: 100

Test date: 2025/03/20 Start time: 15:18:01 End time: 15:28:00

Test duration (min): 10 Data file name: F-000036.cts_data

Comment: All mode

Customer:

Test Result: Pass Status: Test Completed

Pst and limit line European Limits



Plt and limit line



Parameter values recorded during the test:

Vrms at the end of test (Volt):	230.05			
Highest dt (%):	0.00	Test limit (%):	N/A	N/A
T-max (mS):	0	Test limit (mS):	500.1	Pass
Highest dc (%):	0.00	Test limit (%):	3.32	Pass
Highest dmax (%):	0.05	Test limit (%):	4.06	Pass
Highest Pst (10 min. period):	0.218	Test limit:	1.009	Pass
Highest Plt (2 hr. period):	0.093	Test limit:	0.658	Pass

Test Report

Report No.: RKEYS250314098

Date: Mar.20, 2025

Page 36 of 65

8. IMMUNITY TEST

PERFORMANCE CRITERIA DESCRIPTION

EN 301 489-1 V2.2.3 Clause 6 requirements:

Performance criteria for continuous phenomena

During the test, the equipment shall:

- continue to operate as intended;
- not unintentionally transmit;
- not unintentionally change its operating state;
- not unintentionally change critical stored data

Performance criteria for transient phenomena

For all ports and transient phenomena with the exception described below, the following applies:

- The application of the transient phenomena shall not result in a change of the mode of operation (e.g. unintended transmission) or the loss of critical stored data.
- After application of the transient phenomena, the equipment shall operate as intended.

For surges applied to symmetrically operated wired network ports intended to be connected directly to outdoor lines the following criteria applies:

- For products with only one symmetrical port intended for connection to outdoor lines, loss of function is allowed, provided the function is self-recoverable, or can be otherwise restored. Information stored in non-volatile memory, or protected by a battery backup, shall not be lost.
- For products with more than one symmetrical port intended for connection to outdoor lines, loss of function on the port under test is allowed, provided the function is self-recoverable. Information stored in non-volatile memory, or protected by a battery backup, shall not be lost.

EN 301 489-3 V2.3.2 Clause 6 requirements:

6 General performance criteria

6.1 The performance criteria are:

- performance criteria A for immunity tests with phenomena of a continuous nature;
- performance criteria B for immunity tests with phenomena of a transient nature;
- performance criteria C for immunity tests with power interruptions exceeding a certain time.

The equipment shall meet the minimum performance criteria as specified in the following clauses.

6.2 Performance table

6.2.1 Performance criteria overview

Test Report

Report No.: RKEYS250314098

Date: Mar.20, 2025

Page 37 of 65

Criteria	During test	After test (i.e. as a result of the application of the test)
A	Shall operate as intended. (See note). Shall be no loss of function. Shall be no unintentional transmissions.	Shall operate as intended. Shall be no degradation of performance. Shall be no loss of function. Shall be no loss of critical stored data.
B	May be loss of function.	Functions shall be self-recoverable. Shall operate as intended after recovering. Shall be no loss of critical stored data.
C	May be loss of function.	Functions shall be recoverable by the operator. Shall operate as intended after recovering. Shall be no loss of critical stored data

NOTE: Operate as intended during the test allows a level of degradation in accordance with clause 6.2.2.

6.2.2 Minimum performance level

For equipment that supports a PER or FER, the minimum performance level shall be a PER or FER less than or equal to 10 %.

For equipment that does not support a PER or a FER, the minimum performance level shall be no loss of the wireless transmission function needed for the intended use of the equipment.

6.3 Performance criteria for Continuous phenomena

The performance criteria A shall apply.

Where the EUT is a transmitter in standby mode, unintentional transmission shall not occur during the test.

Where the EUT is a transceiver in receive mode, unintentional transmission shall not occur during the test.

6.4 Performance criteria for Transient phenomena

The performance criteria B shall apply, except for voltage dips greater than or equal to 100 ms and voltage interruptions of 5 000 ms duration, for which performance criteria C shall apply.

Where the EUT is a transmitter in standby mode, unintentional transmission shall not occur as a result of the application of the test.

Where the EUT is a transceiver in receive mode, unintentional transmission shall not occur as a result of the application of the test.

Test Report

Report No.: RKEYS250314098

Date: Mar.20, 2025

Page 38 of 65

EN 55035 requirements

Criteria A:	During and after the test the EUT shall continue to operate as intended without operator intervention. No degradation of performance or loss of function is allowed below a minimum performance level specified by the manufacturer when the EUT is used as intended. The performance level may be replaced by a permissible loss of performance. If the minimum performance level or the permissible performance loss is not specified by the manufacturer, then either of these may be derived from the product description and documentation, and by what the user may reasonably expect from the EUT if used as intended.
Criteria B:	After the test, the EUT shall continue to operate as intended without operator intervention. No degradation of performance or loss of function is allowed, after the application of the phenomena below a performance level specified by the manufacturer, when the EUT is used as intended. The performance level may be replaced by a permissible loss of performance. During the test, degradation of performance is allowed. However, no change of operating state or stored data is allowed to persist after the test. If the minimum performance level (or the permissible performance loss) is not specified by the manufacturer, then either of these may be derived from the product description and documentation, and by what the user may reasonably expect from the EUT if used as intended.
Criteria C:	During and after testing, a temporary loss of function is allowed, provided the function is self-recoverable, or can be restored by the operation of the controls or cycling of the power to the EUT by the user in accordance with the manufacturer's instructions. Functions, and/or information stored in non-volatile memory, or protected by a battery backup, shall not be lost.

Test Report

Report No.: RKEYS250314098

Date: Mar.20, 2025

Page 39 of 65

8.1. ELECTROSTATIC DISCHARGE (ESD)

8.1.1. TEST SPECIFICATION

Test Standard:	EN 301 489-1 EN 301 489-3 BS EN 55035
Basic Standard:	BS EN 61000-4-2
Discharge Impedance:	330 Ω
Charging Capacity:	150 pF
Discharge Voltage:	Air Discharge: ± 8 kV (Direct) Contact Discharge: ± 4 kV (Direct/Indirect)
Polarity:	Positive & Negative
Number of Discharge:	10 (Air discharge for single polarity discharge) 25 (Contact discharge for single polarity discharge)
Discharge Mode:	1 time/s
Performance Criterion:	B

8.1.2. TEST PROCEDURE

The discharges shall be applied in two ways:

- Contact discharges to the conductive surfaces and coupling planes:
50 dischargers (25 with positive and 25 with negative polarity) shall be applied on each accessible metallic part of the enclosure, terminals are excluded. In case of a non-conductive enclosure, dischargers shall be applied on the horizontal or vertical coupling planes. Test shall be performed at a maximum repetition rate of one discharge per second.
- Air discharges at slots and apertures and insulating surfaces:
On those parts of the EUT where it is not possible to perform contact discharge testing, the equipment should be investigated to identify user accessible points where breakdown may occur. Such points are tested using the air discharge method. This investigation should be restricted to those area normally handled by the user. A minimum of 10 single air discharges shall be applied to the selected test point for each such area.

The basic test procedure was in accordance with EN 61000-4-2:

- The EUT was located 0.1 m minimum from all side of the HCP (dimensions 1.6 m x 0.8 m).
- The support units were located another table 30 cm away from the EUT, but direct support unit was/were located at same location as EUT on the HCP and keep at a distance of 10cm with EUT.
- The time interval between two successive single discharges was at least 1 second.

Guangdong KEYS Testing Technology Co., Ltd.

Address: Building 1, No.18, Shihuan Road, Dongcheng Subdistrict, Dongguan, Guangdong, China
Tel: +86-0769-89798319 <http://www.keys-lab.com> E-mail: info@keys-lab.com

This report is only responsible for the test results of the samples submitted for inspection, and is not responsible for the source of the samples submitted for inspection. This report shall not be altered, increased or deleted. Without written approval of KEYS, this test report shall not be copied except in full and published as advertisement.

Test Report

Report No.: RKEYS250314098

Date: Mar.20, 2025

Page 40 of 65

- d) Contact discharges were applied to the non-insulating coating, with the pointed tip of the generator penetrating the coating and contacting the conducting substrate.
- e) Air discharges were applied with the round discharge tip of the discharge electrode approaching the EUT as fast as possible (without causing mechanical damage) to touch the EUT. After each discharge, the ESD generator was removed from the EUT and re-triggered for a new single discharge. The test was repeated until all discharges were complete.
- f) At least ten single discharges (in the most sensitive polarity) were applied at the front edge of each HCP opposite the center point of each unit of the EUT and 0.1 meter from the front of the EUT. The long axis of the discharge electrode was in the plane of the HCP and perpendicular to its front edge during the discharge.
- g) At least ten single discharges (in the most sensitive polarity) were applied to the center of one vertical edge of the Vertical Coupling Plane (VCP) in sufficiently different positions that the four faces of the EUT were completely illuminated. The VCP (dimensions 0.5 m x 0.5 m) was placed vertically to and 0.1 meter from the EUT.

Test Report

Report No.: RKEYS250314098

Date: Mar.20, 2025

Page 41 of 65

8.1.3. TEST SETUP

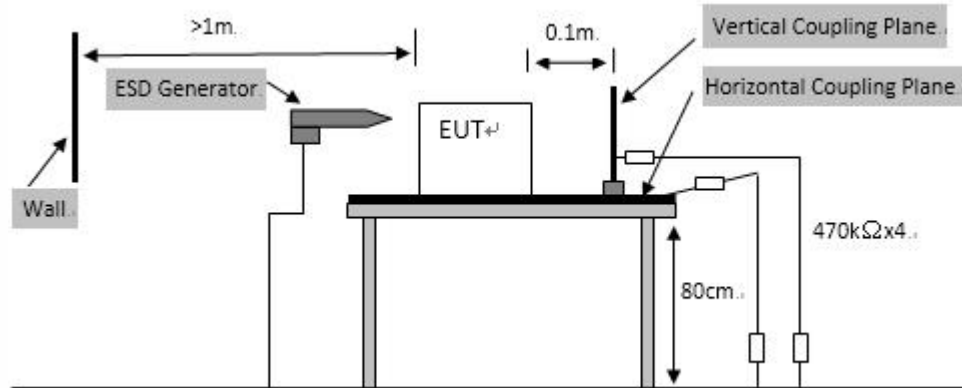

For the actual test configuration, please refer to the related item – Photographs of the Test Configuration.

Note:

1) TABLE-TOP EQUIPMENT

The configuration consisted of a wooden table 0.8 meters high standing on the ground reference plane (GRP). The GRP consisted of a sheet of aluminum at least 0.25 mm thick, and 2.5 meters square connected to the protective grounding system. A horizontal coupling plane (HCP) (1.6 m x 0.8 m) was placed on the table and attached to the GRP by means of a cable with 940k total impedance. The equipment under test, was installed in a representative system as described in section 7 of EN 61000-4-2, and its cables were placed on the HCP and isolated by an insulating support of 0.5 mm thickness. A distance of 1-meter minimum was provided between the EUT and the walls of the laboratory and any other metallic structure.

2) FLOOR-STANDING EQUIPMENT

The equipment under test was installed in a representative system as described in section 7 of IEC 61000-4-2, and its cables were isolated from the ground reference plane by an insulating support of 0.1 meter thickness. The GRP consisted of a sheet of aluminum that is at least 0.25 mm thick, and 2.5 meters square connected to the protective grounding system and extended at least 0.5 meters from the EUT on all sides.

Test Report

Report No.: RKEYS250314098

Date: Mar.20, 2025

Page 42 of 65

8.1.4. TEST RESULT

Product	Night Stand	Environmental Conditions	24.1°C, 55% RH, 101.14 kPa
Model	YS-02NS011A	Tested By	Joy Jiang
Test mode	All mode	Test Result	Pass

Air Discharge					
Test Points	Test Levels	Results			
	± 8 Kv	Pass	Fail	Observation	Performance Criterion
Slot	<input checked="" type="checkbox"/>	<input checked="" type="checkbox"/>	<input type="checkbox"/>	Note <input type="checkbox"/> 1 <input checked="" type="checkbox"/> 2 <input type="checkbox"/> 3	B
LCD	<input checked="" type="checkbox"/>	<input checked="" type="checkbox"/>	<input type="checkbox"/>	Note <input type="checkbox"/> 1 <input checked="" type="checkbox"/> 2 <input type="checkbox"/> 3	B

Contact Discharge					
Test Points	Test Levels	Results			
	± 4 Kv	Pass	Fail	Observation	Performance Criterion
Metal	<input checked="" type="checkbox"/>	<input checked="" type="checkbox"/>	<input type="checkbox"/>	Note <input type="checkbox"/> 1 <input checked="" type="checkbox"/> 2 <input type="checkbox"/> 3	B
HCP	<input checked="" type="checkbox"/>	<input checked="" type="checkbox"/>	<input type="checkbox"/>	Note <input type="checkbox"/> 1 <input checked="" type="checkbox"/> 2 <input type="checkbox"/> 3	B
VCP 4 Points	<input checked="" type="checkbox"/>	<input checked="" type="checkbox"/>	<input type="checkbox"/>	Note <input type="checkbox"/> 1 <input checked="" type="checkbox"/> 2 <input type="checkbox"/> 3	B

Note:

- 1) No degradation in performance of the EUT was observed.
- 2) During the test, Loss of functionality, after the experiment, the function can automatically return to normal.
- 3) Loss of functionality, but self-recoverable by user, without loss of information or settings.

Test Report

Report No.: RKEYS250314098

Date: Mar.20, 2025

Page 43 of 65

8.2. RADIATED, RADIO-FREQUENCY, ELECTROMAGNETIC FIELD (RS)

8.2.1. TEST SPECIFICATION

Test Standard:	EN 301 489-1 EN 301 489-3 BS EN 55035
Basic Standard:	BS EN IEC 61000-4-3
Frequency Range:	EN 301 489-1/-3 80 ~6GHz BS EN 55035: 80 MHz ~ 1000 MHz, 1800MHz, 2600MHz, 3500MHz, 5000MHz
Field Strength:	3 V/m
Modulation:	1 kHz Sine Wave, 80 %, AM Modulation
Frequency Step:	1 % of preceding frequency value
Polarity of Antenna:	Horizontal and Vertical
Test Distance:	3 m
Antenna Height:	1.5 m
Performance Criterion:	A

8.2.2. TEST PROCEDURE

The test procedure was in accordance with BS EN IEC 61000-4-3

- The testing was performed in a fully anechoic chamber. The transmit antenna was located at a distance of 3 meters from the EUT.
- The frequency range is swept from 80 MHz to 1000 MHz, with the signal 80% amplitude modulated with a 1 kHz sine-wave. The rate of sweep did not exceed 1.5×10^{-3} decade/s, where the frequency range is swept incrementally, the step size was 1 % of preceding frequency value.
- The dwell time at each frequency shall be not less than the time necessary for the EUT to be able to respond.
- The test was performed with the EUT exposed to both vertically and horizontally polarized fields on each of the four sides.

Test Report

Report No.: RKEYS250314098

Date: Mar.20, 2025

Page 44 of 65

8.2.3. TEST SETUP

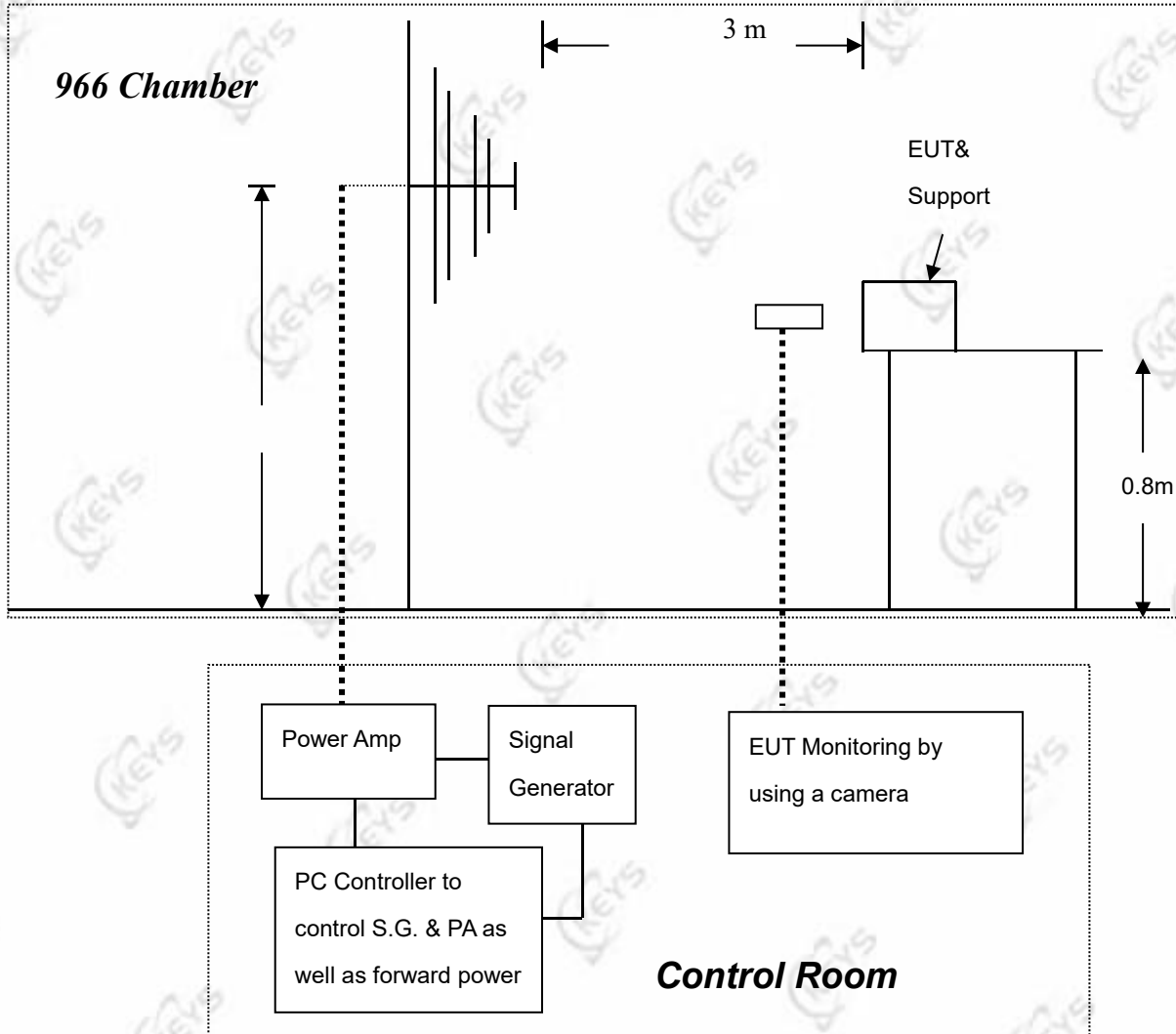

For the actual test configuration, please refer to the related item – Photographs of the Test Configuration.

Note:

TABLETOP EQUIPMENT

The EUT installed in a representative system as described in section 7 of EN 61000-4-3 was placed on a non-conductive table 0.8 meters in height. The system under test was connected to the power and signal wire according to relevant installation instructions.

FLOOR STANDING EQUIPMENT

The EUT installed in a representative system as described in section 7 of IEC 61000-4-3 was placed on a non-conductive wood support 0.1 meters in height. The system under test was connected to the power and signal wire according to relevant installation instructions.

Guangdong KEYS Testing Technology Co., Ltd.

Address: Building 1, No.18, Shihuan Road, Dongcheng Subdistrict, Dongguan, Guangdong, China
 Tel: +86-0769-89798319 <http://www.keys-lab.com> E-mail: info@keys-lab.com

This report is only responsible for the test results of the samples submitted for inspection, and is not responsible for the source of the samples submitted for inspection. This report shall not be altered, increased or deleted. Without written approval of KEYS, this test report shall not be copied except in full and published as advertisement.

Test Report

Report No.: RKEYS250314098

Date: Mar.20, 2025

Page 45 of 65

8.2.4. TEST RESULT

Product	Night Stand	Environmental Conditions	24.1°C, 51% RH, 101.12 kPa
Model	YS-02NS011A	Tested By	Joy Jiang
Test mode	All mode	Test Result	Pass

For EN 301 489-1/-3

Frequency (MHz)	Polarity	Position	Field Strength (V/m)	Observation	Performance Criterion
80 ~6GHz	V&H	Front	3	Note <input checked="" type="checkbox"/> 1 <input type="checkbox"/> 2 <input type="checkbox"/> 3	A
	V&H	Rear	3	Note <input checked="" type="checkbox"/> 1 <input type="checkbox"/> 2 <input type="checkbox"/> 3	A
	V&H	Left	3	Note <input checked="" type="checkbox"/> 1 <input type="checkbox"/> 2 <input type="checkbox"/> 3	A
	V&H	Right	3	Note <input checked="" type="checkbox"/> 1 <input type="checkbox"/> 2 <input type="checkbox"/> 3	A

For EN 55035

Frequency (MHz)	Polarity	Position	Field Strength (V/m)	Observation	Performance Criterion
80 ~1000 1800 2600 3500 5000	V&H	Front	3	Note <input checked="" type="checkbox"/> 1 <input type="checkbox"/> 2 <input type="checkbox"/> 3	A
	V&H	Rear	3	Note <input checked="" type="checkbox"/> 1 <input type="checkbox"/> 2 <input type="checkbox"/> 3	A
	V&H	Left	3	Note <input checked="" type="checkbox"/> 1 <input type="checkbox"/> 2 <input type="checkbox"/> 3	A
	V&H	Right	3	Note <input checked="" type="checkbox"/> 1 <input type="checkbox"/> 2 <input type="checkbox"/> 3	A

Note:

- 1) No degradation in performance of the EUT was observed.
- 2) During the test, Loss of functionality, after the experiment, the function can automatically return to normal.
- 3) Loss of functionality, but self-recoverable by user, without loss of information or settings.

Test Report

Report No.: RKEYS250314098

Date: Mar.20, 2025

Page 46 of 65

8.3. ELECTRICAL FAST TRANSIENT (EFT)

8.3.1. TEST SPECIFICATION

Test Standard:	EN 301 489-1/-3 BS EN 55035
Basic Standard:	BS EN 61000-4-4
Test Voltage:	Power Line: ± 1 kV Signal/Control Line: ± 0.5 kV
Polarity:	Positive & Negative
Impulse Frequency:	5 kHz
Impulse Wave-shape:	5/50 ns
Burst Duration:	15 ms
Burst Period:	300 ms
Test Duration:	2 mins
Performance Criterion:	B

8.3.2. TEST PROCEDURE

EUT is placed on a 0.1 m tall wooden table.

EUT operate at normal mode, the transient/burst was 5/50 ns in accordance with BS EN 61000-4-4, both positive and negative polarity burst waveform were applied.

The duration time of each test line was 2 minutes.

8.3.3. TEST SETUP

The EUT installed in a representative system as described in section 7 of BSEN 61000-4-4.

For the actual test configuration, please refer to the related item – photographs of the test configuration.

Test Report

Report No.: RKEYS250314098

Date: Mar.20, 2025

Page 47 of 65

8.3.4. TEST RESULT

Product	Night Stand	Environmental Conditions	24.1°C,52 % RH, 101.1 kPa
Model	YS-02NS011A	Tested By	Joy Jiang
Test mode	All mode	Test Result	Pass

Test Point	Polarity	Test Level (kV)	Observation	Performance Criterion
L	+/-	1	Note <input type="checkbox"/> 1 <input checked="" type="checkbox"/> 2 <input type="checkbox"/> 3	B
N	+/-	1	Note <input type="checkbox"/> 1 <input checked="" type="checkbox"/> 2 <input type="checkbox"/> 3	B
L – N	+/-	1	Note <input type="checkbox"/> 1 <input checked="" type="checkbox"/> 2 <input type="checkbox"/> 3	B
PE	+/-	1	Note <input type="checkbox"/> 1 <input checked="" type="checkbox"/> 2 <input type="checkbox"/> 3	B
L – PE	+/-	1	Note <input type="checkbox"/> 1 <input checked="" type="checkbox"/> 2 <input type="checkbox"/> 3	B
N – PE	+/-	1	Note <input type="checkbox"/> 1 <input checked="" type="checkbox"/> 2 <input type="checkbox"/> 3	B
L – N – PE	+/-	1	Note <input type="checkbox"/> 1 <input checked="" type="checkbox"/> 2 <input type="checkbox"/> 3	B
RJ45 UTP cable	--	--	N/A	N/A

Note:

- 1) No degradation in performance of the EUT was observed.
- 2) During the test, Loss of functionality, after the experiment, the function can automatically return to normal.
- 3) Loss of functionality, but self-recoverable by user, without loss of information or settings.

Test Report

Report No.: RKEYS250314098

Date: Mar.20, 2025

Page 48 of 65

8.4. SURGE IMMUNITY TEST

8.4.1. TEST SPECIFICATION

Test Standard:	EN 301 489-1/-3 BS EN 55035
Basic Standard:	BS EN 61000-4-5
Wave-Shape:	Combination Wave 1.2/50 μ s Open Circuit Voltage 8/20 μ s Short Circuit Current
Test Voltage:	Power Port ~ Line to line: ± 1 kV, Line to ground: ± 2 kV
Surge Input/Output:	Power Line: L-N / L-PE / N-PE
Generator Source Impedance:	2 Ω between networks 12 Ω between network and ground
Polarity:	Positive/Negative
Phase Angle:	0°/90°/180°/270°
Pulse Repetition Rate:	1 time / min
Number of Tests:	5 positive polarity pulses, and 5 negative polarity pulses
Performance Criterion:	B

8.4.2. TEST PROCEDURE

EUT is placed on a 0.8 m tall wooden table.

EUT operate at normal mode, two types of combination wave generator (1.2/50 μ s open-circuit voltage and 8/20 μ s short-circuit current) are applied to the EUT power supply terminals via the capacitive coupling network.

The power cord between the EUT and the coupling/decoupling network shall not exceed 2 m in length.

Test Report

Report No.: RKEYS250314098

Date: Mar.20, 2025

Page 49 of 65

8.4.3. TEST SETUP

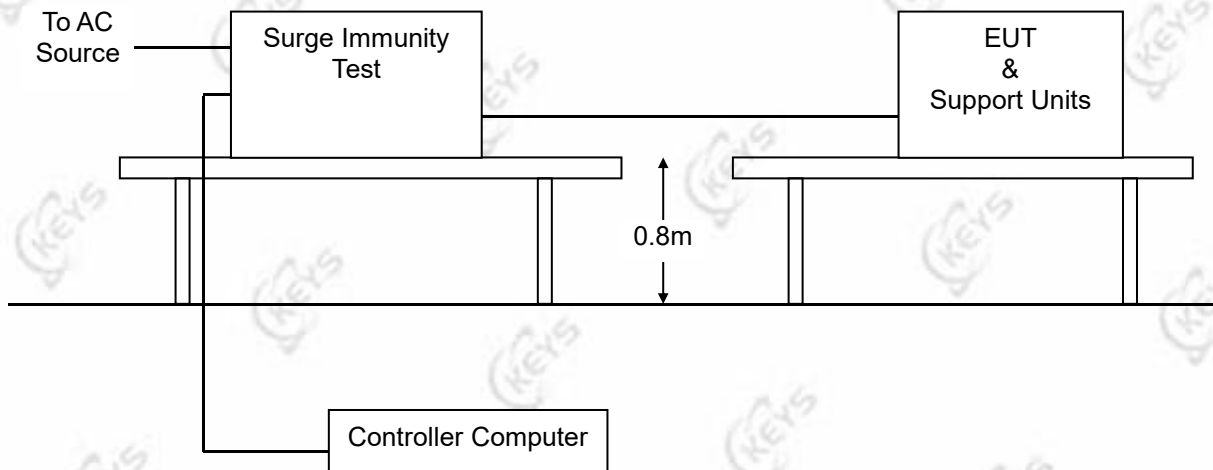

For the actual test configuration, please refer to the related item – Photographs of the Test Configuration.

8.4.4. TEST RESULT

Product	Night Stand	Environmental Conditions	24.5°C,52 % RH, 101.1 kPa
Model	YS-02NS011A	Tested By	Joy Jiang
Test mode	All mode	Test Result	Pass

Test Point	Polarity	Test Level (kV)	Observation	Performance Criterion
L - N	+/-	1	Note <input type="checkbox"/> 1 <input checked="" type="checkbox"/> 2 <input type="checkbox"/> 3	B
L - PE	+/-	2	Note <input type="checkbox"/> 1 <input checked="" type="checkbox"/> 2 <input type="checkbox"/> 3	B
N - PE	+/-	2	Note <input type="checkbox"/> 1 <input checked="" type="checkbox"/> 2 <input type="checkbox"/> 3	B

Note:

- 1) No degradation in performance of the EUT was observed.
- 2) During the test, Loss of functionality, after the experiment, the function can automatically return to normal.
- 3) Loss of functionality, but self-recoverable by user, without loss of information or settings.

Test Report

Report No.: RKEYS250314098

Date: Mar.20, 2025

Page 50 of 65

8.5. CONDUCTED RADIO FREQUENCY DISTURBANCES (CS)

8.5.1. TEST SPECIFICATION

Test Standard:	EN 301 489-1/-3 BS EN 55035
Basic Standard:	BS EN IEC 61000-4-6
Frequency Range:	0.15MHz-10MHz: 3V, 10MHz-30MHz: 3V to 1V 30MHz-80MHz: 1V
Field Strength:	3 V
Modulation:	1 kHz Sine Wave, 80 %, AM Modulation
Frequency Step:	1 % of preceding frequency value
Coupled cable:	Power Mains, Shielded
Coupling device:	CDN-M3/2 (3 wires/2 wires)
Performance Criterion:	A

8.5.2. TEST PROCEDURE

The EUT shall be tested within its intended operating and climatic conditions. The test shall be performed with the test generator connected to each of the coupling and decoupling devices in turn, while the other non-excited RF input ports of the coupling devices are terminated by a 50 Ω load resistor. The frequency range was swept from 150 kHz to 80 MHz, using the signal level established during the setting process and with a disturbance signal of 80 % amplitude. The signal was modulated with a 1 kHz sine wave, pausing to adjust the RF signal level or the switch coupling devices as necessary. The sweep rate was 1.5×10^{-3} decades/s. Where the frequency range is swept incrementally, the step size was 1 % of preceding frequency value the dwell time of the amplitude modulated carrier at each frequency was 0.5 s.

8.5.3. TEST SETUP

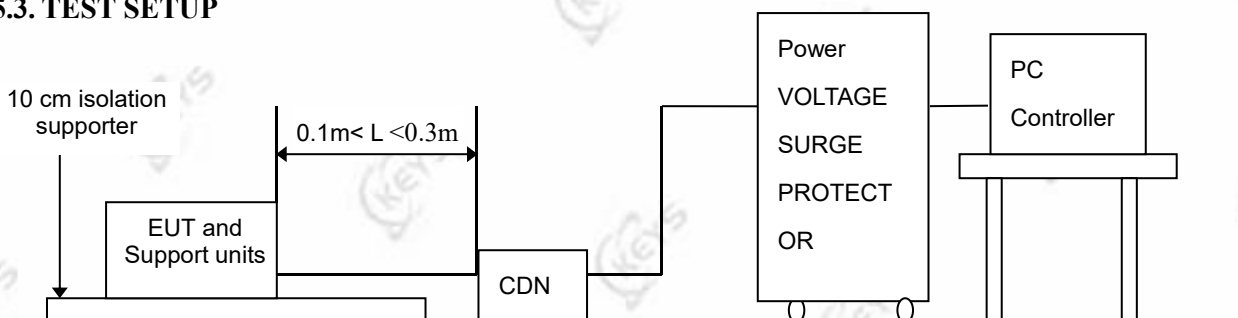

For the actual test configuration, please refer to the related item – Photographs of the Test Configuration

Note: 1) The EUT is setup 0.1 m above Ground Reference Plane

- 2) All relevant cables shall be provided with the appropriate coupling and decoupling devices at a distance between 0.1 meters and 0.3 meters from the projected geometry of the EUT on the ground reference plane.

Test Report

Report No.: RKEYS250314098

Date: Mar.20, 2025

Page 51 of 65

8.5.4. TEST RESULT

Product	Night Stand	Environmental Conditions	24.1°C, 51 % RH, 101.21 kPa
Model	YS-02NS011A	Tested By	Joy Jiang
Test mode	All mode	Test Result	Pass

For EN 301 489-1/-3

Frequency (MHz)	Field Strength (Vrms)	Injected Position	Injection Method	Observation	Performance Criterion
0.15-80	3	AC Mains	CDN-M3	Note <input checked="" type="checkbox"/> 1 <input type="checkbox"/> 2 <input type="checkbox"/> 3	A

For EN 55035

Frequency (MHz)	Field Strength (Vrms)	Injected Position	Injection Method	Observation	Performance Criterion
0.15-10	3	AC Mains	CDN-M3	Note <input checked="" type="checkbox"/> 1 <input type="checkbox"/> 2 <input type="checkbox"/> 3	A
10-30	3V to 1V	AC Mains	CDN-M3	Note <input checked="" type="checkbox"/> 1 <input type="checkbox"/> 2 <input type="checkbox"/> 3	A
30-80	1V	AC Mains	CDN-M3	Note <input checked="" type="checkbox"/> 1 <input type="checkbox"/> 2 <input type="checkbox"/> 3	A

Note:

- 3) No degradation in performance of the EUT was observed.
- 4) During the test, Loss of functionality, after the experiment, the function can automatically return to normal.
- 3) Loss of functionality, but self-recoverable by user, without loss of information or settings.

Test Report

Report No.: RKEYS250314098

Date: Mar.20, 2025

Page 52 of 65

8.6. POWER FREQUENCY MAGNETIC FIELD

8.6.1. TEST SPECIFICATION

Test Standard:	BS EN 55035
Basic Standard:	BS EN 61000-4-8
Frequency Range:	50 Hz
Field Strength:	1 A/m
Observation Time:	5 minutes
Inductance Coil:	Rectangular type, 1 m x 1 m
Performance Criterion:	A

8.6.2. TEST PROCEDURE

The equipment is configured and connected to satisfy its functional requirements. It shall be placed on the GRP with the interposition of a 0.1 m-thick insulating support.

The equipment cabinets shall be connected to the safety earth directly on the GRP via the earth terminal of the EUT.

The power supply, input and output circuits shall be connected to the sources of power supply, control and signal.

The cables supplied or recommended by the equipment manufacturer shall be used. 1 meter of all cables used shall be exposed to the magnetic field.

Test Report

Report No.: RKEYS250314098

Date: Mar.20, 2025

Page 53 of 65

8.6.3. TEST SETUP

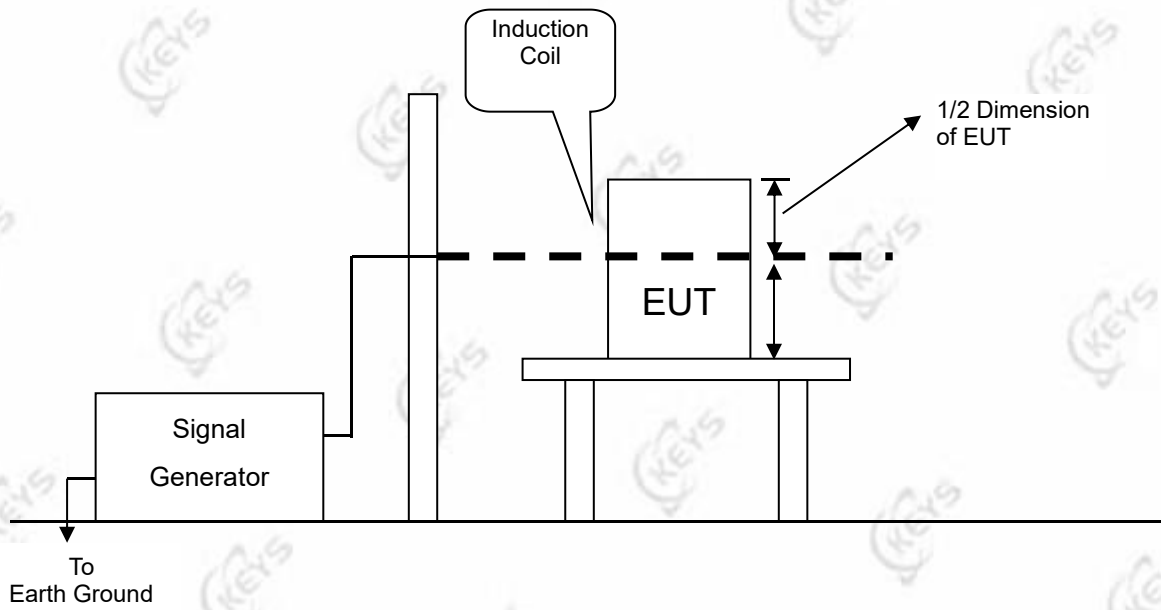

For the actual test configuration, please refer to the related item – Photographs of the Test Configuration
Note:

TABLETOP EQUIPMENT

The equipment shall be subjected to the test magnetic field by using the induction coil of standard dimension (1 m x 1 m). The induction coil shall then be rotated by 90 degrees in order to expose the EUT to the test field with different orientations.

FLOOR-STANDING EQUIPMENT

The equipment shall be subjected to the test magnetic field by using induction coils of suitable dimensions. The test shall be repeated by moving and shifting the induction coils, in order to test the whole volume of the EUT for each orthogonal direction. The test shall be repeated with the coil shifted to different positions along the side of the EUT, in steps corresponding to 50 % of the shortest side of the coil. The induction coil shall then be rotated by 90 degrees in order to expose the EUT to the test field with different orientations.

Test Report

Report No.: RKEYS250314098

Date: Mar.20, 2025

Page 54 of 65

8.6.4. TEST RESULT

Product	Night Stand	Environmental Conditions	24.1°C,53% RH, 101.12 kPa
Model	YS-02NS011A	Tested By	Joy Jiang
Test mode	All mode	Test Result	Pass

Antenna aspect	Duration (min)	Field Strength (A/m)	Observation	Performance Criterion
X	5 min	1	Note <input checked="" type="checkbox"/> 1 <input type="checkbox"/> 2 <input type="checkbox"/> 3	A
Y	5 min	1	Note <input checked="" type="checkbox"/> 1 <input type="checkbox"/> 2 <input type="checkbox"/> 3	A
Z	5 min	1	Note <input checked="" type="checkbox"/> 1 <input type="checkbox"/> 2 <input type="checkbox"/> 3	A

Note:

- 1) No degradation in performance of the EUT was observed.
- 2) During the test, Loss of functionality, after the experiment, the function can automatically return to normal.
- 3) Loss of functionality, but self-recoverable by user, without loss of information or settings.

Test Report

Report No.: RKEYS250314098

Date: Mar.20, 2025

Page 55 of 65

8.7. VOLTAGE DIP & VOLTAGE INTERRUPTIONS

8.7.1. TEST SPECIFICATION

Test Standard:	EN 301 489-1/-3 BS EN 55035
Basic Standard:	BS EN IEC 61000-4-11
Test Duration Time:	3 test events in sequence
Interval Between Event:	10 seconds
Phase Angle:	0°
Test Cycle:	3 times
Performance Criterion:	EN 301 489-1/-3 voltage dip: 0 % residual voltage for 0,5 cycle; voltage dip: B 0 % residual voltage for 1 cycle; voltage dip: B 70 % residual voltage for 25 cycles (at 50 Hz);B Voltage interruption: 0 % residual voltage for 250 cycles (at 50 Hz): C
	BS EN 55035 voltage dip: <5% residual voltage for 0,5 cycle;B voltage dip: 70 % residual voltage for 25 cycles (at 50 Hz);C Voltage interruption: <5% residual voltage for 250 cycles (at 50 Hz).C

8.7.2. TEST PROCEDURE

The EUT and support units were located on a wooden table, 0.8 m away from ground floor.

Setting the parameter of tests and then perform the test software of test simulator.

Changes to the voltage level shall occur at 0 degree crossing point in the a.c. voltage waveform.

Record the test result in test record form.

Test Report

Report No.: RKEYS250314098

Date: Mar.20, 2025

Page 56 of 65

8.7.3. TEST SETUP

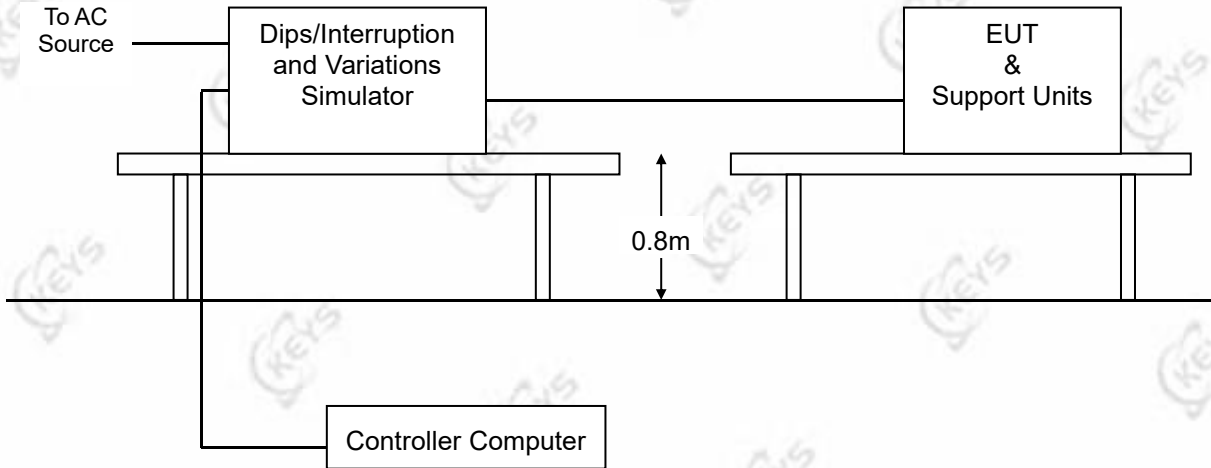

For the actual test configuration, please refer to the related item – Photographs of the Test Configuration.

Test Report

Report No.: RKEYS250314098

Date: Mar.20, 2025

Page 57 of 65

8.7.4. TEST RESULT

Product	Night Stand	Environmental Conditions	24.1°C,53% RH, 101.1 kPa
Model	YS-02NS011A	Tested By	Joy Jiang
Test mode	All mode	Test Result	Pass

Test Power: 230 Vac, 50 Hz			
Voltage (% Reduction)	Duration (Period)	Observation	Performance Criterion
100	0.5 P	Note <input type="checkbox"/> 1 <input checked="" type="checkbox"/> 2 <input type="checkbox"/> 3	B
30	1	Note <input type="checkbox"/> 1 <input checked="" type="checkbox"/> 2 <input type="checkbox"/> 3	B
100	25	Note <input type="checkbox"/> 1 <input type="checkbox"/> 2 <input checked="" type="checkbox"/> 3	C
30	25 0	Note <input type="checkbox"/> 1 <input type="checkbox"/> 2 <input checked="" type="checkbox"/> 3	C

Note:

- 1) No degradation in performance of the EUT was observed.
- 2) During the test, Loss of functionality, after the experiment, the function can automatically return to normal.
- 3) Loss of functionality, but self-recoverable by user, without loss of information or settings.

Test Report

Report No.: RKEYS250314098

Date: Mar.20, 2025

Page 58 of 65

9. PHOTOGRAPHS OF THE TEST CONFIGURATION

CONDUCTED EMISSION TEST

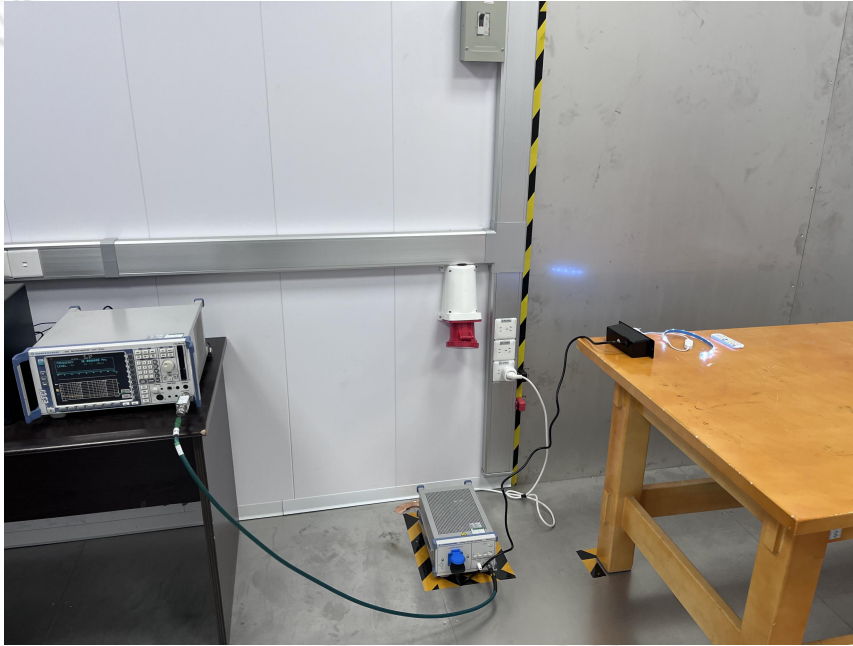

RADIATED EMISSION TEST

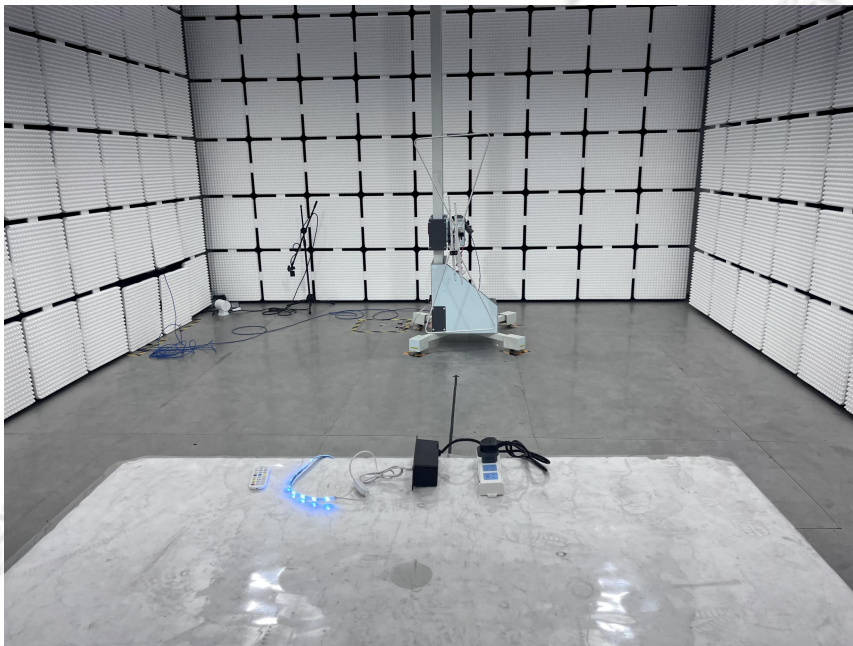

Test Report

Report No.: RKEYS250314098

Date: Mar.20, 2025

Page 59 of 65

ESD TEST

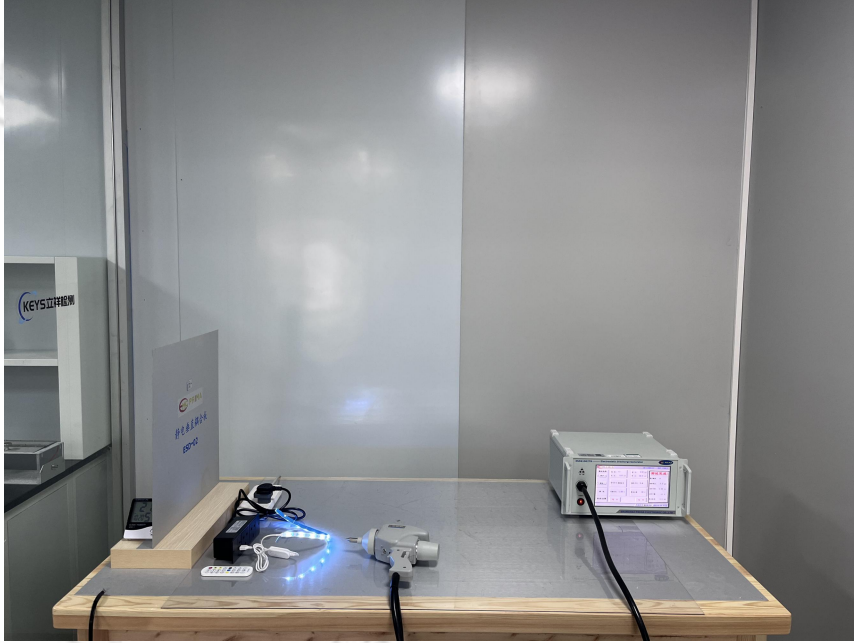

Test Report

Report No.: RKEYS250314098

Date: Mar.20, 2025

Page 60 of 65

10. PHOTOGRAPHS OF EUT

Detail of:

- front
- rear
- right side
- left side
- top
- bottom
- internal



Detail of:

- front
- rear
- right side
- left side
- top
- bottom
- internal



Test Report

Report No.: RKEYS250314098

Date: Mar.20, 2025

Page 61 of 65

Detail of:

- front
- rear
- right side
- left side
- top
- bottom
- internal



Detail of:

- front
- rear
- right side
- left side
- top
- bottom
- internal



Test Report

Report No.: RKEYS250314098

Date: Mar.20, 2025

Page 62 of 65

Detail of:

- front
- rear
- right side
- left side
- top
- bottom
- internal



Detail of:

- front
- rear
- right side
- left side
- top
- bottom
- internal

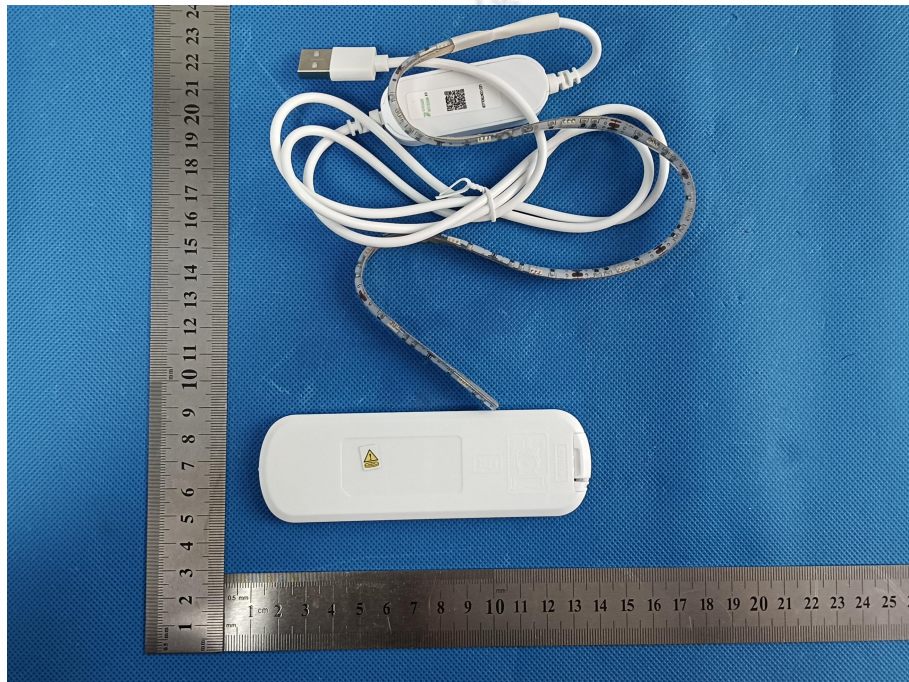

Test Report

Report No.: RKEYS250314098

Date: Mar.20, 2025

Page 63 of 65

Detail of:

- front
- rear
- right side
- left side
- top
- bottom
- internal



Detail of:

- front
- rear
- right side
- left side
- top
- bottom
- internal



Test Report

Report No.: RKEYS250314098

Date: Mar.20, 2025

Page 64 of 65

Detail of:

- front
- rear
- right side
- left side
- top
- bottom
- internal



Detail of:

- front
- rear
- right side
- left side
- top
- bottom
- internal



Test Report

Report No.: RKEYS250314098

Date: Mar.20, 2025

Page 65 of 65

Detail of:

- front
- rear
- right side
- left side
- top
- bottom
- internal



*** End of Report ***