

HIBISCUS

IN-WALL SHOWER DIVERTER TRIM

SKU: 948902



FEATURES

- Shape: Square
- Handle Type: Lever
- Installation Type: Wall Mount
- Assembly Required: No
- Design: Modern
- Metal Handle.
- Metal Escutcheon
- Six Total Settings Allow For Shared Water Flow Between Outlets, Giving You the Ability to Use Two Functions at Once

Optional Rough-In Valve:

- Available Single-Function Diverter Valve Cartridge Restricts Water Flow to One Outlet at a Time
- Brass Valve Body
- Not Intended as a Shut off Valve
- Ceramic Cartridge
- Must be Installed in Accordance With Provided Installation Instructions

CONTENTS

TRIM	PAGE 2
ROUGH-IN VALVE	PAGE 3

REVISED 04/07/2021

HIBISCUS

IN-WALL SHOWER DIVERTER TRIM

SKU: 948902

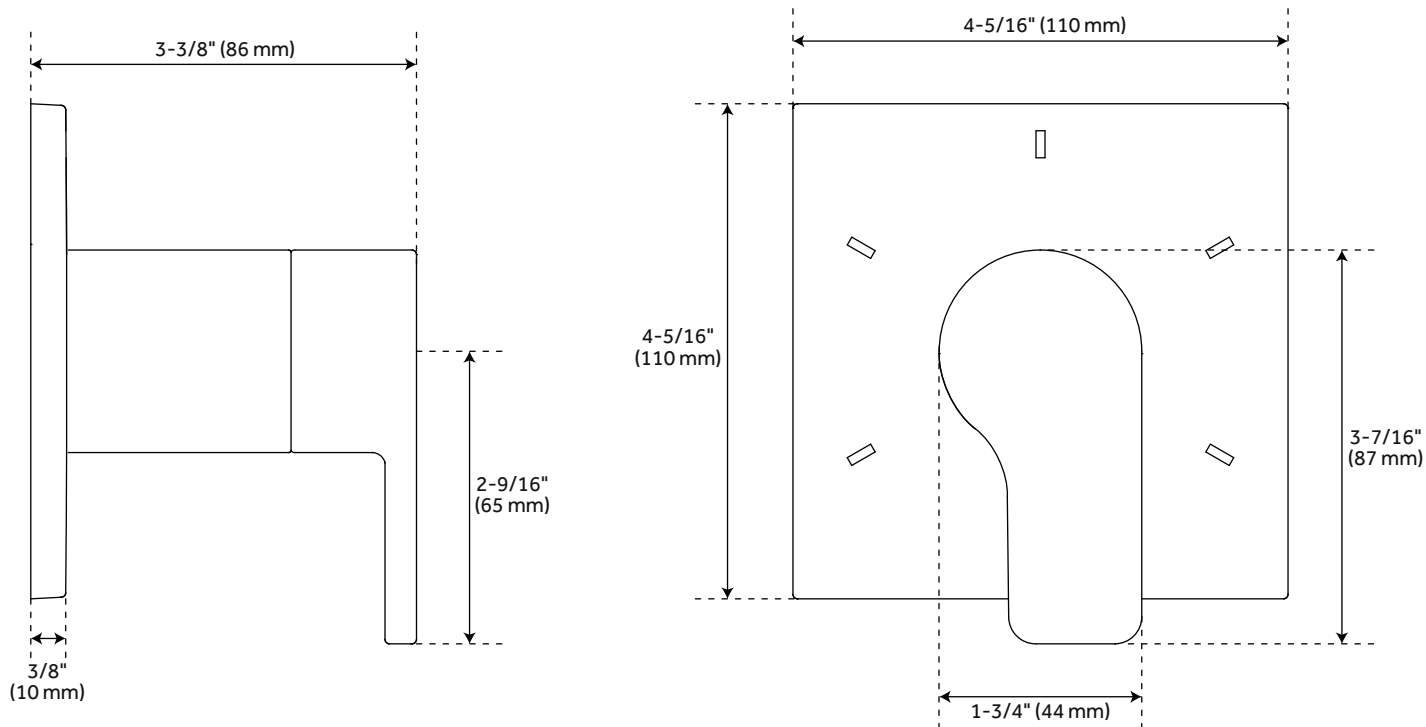

FEATURES

- Material: Brass
- Width: 4-5/16"
- Height: 4-5/16"
- Depth: 3-3/8"
- Connection: 3/4"-14 NPT
- Wall Thickness Range: 1" to 1-3/4"

CODES/STANDARDS

- cUPC
- ASME A112.18.1/CSA B125.1
- ICC/ANSI A117.1 (when installed according to ADA standards)
- Massachusetts Accepted

PRODUCT IMAGE



All dimensions and specifications are nominal and may vary. Use actual products for accuracy in critical situations.

PAGE 2
Code: SHHB9005

HIBISCUS

OPTIONAL 3-WAY IN-WALL DIVERTER ROUGH-IN VALVE - 3/4"

SKU: 948902

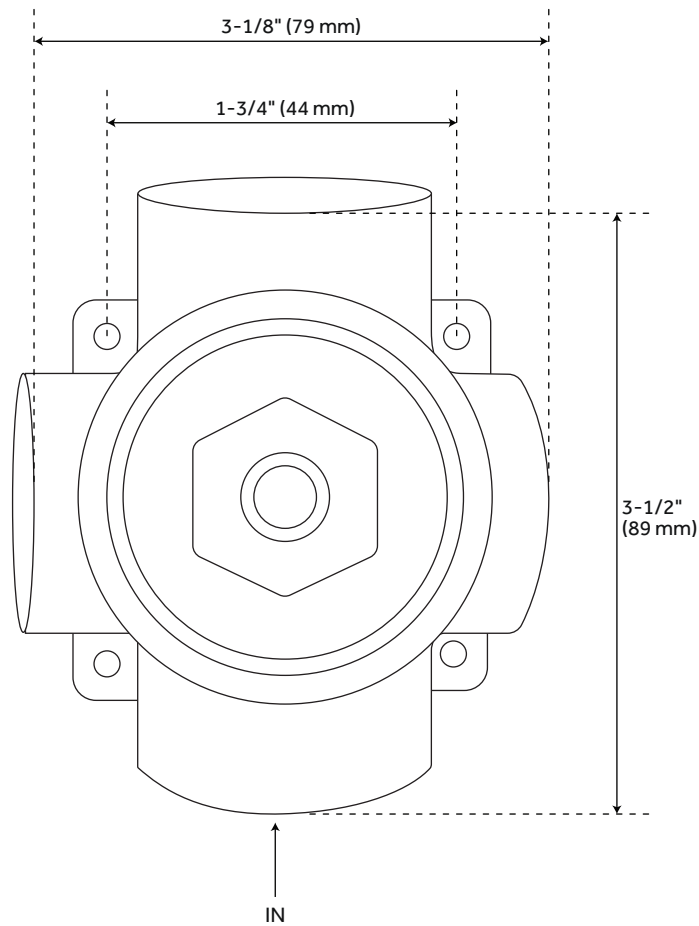

FEATURES

Material: Brass
Connection: 3/4"-14 NPT
For Installations Only Requiring 2 Outlets,
the 3rd Outlet May be Looped into
One of the Existing Pipes

CODES/STANDARDS

cUPC
ASME A112.18.1/CSA B125.1
Massachusetts Accepted

PRODUCT IMAGE



All dimensions and specifications are nominal and may vary. Use actual products for accuracy in critical situations.

PAGE 3
Code: SH6103