

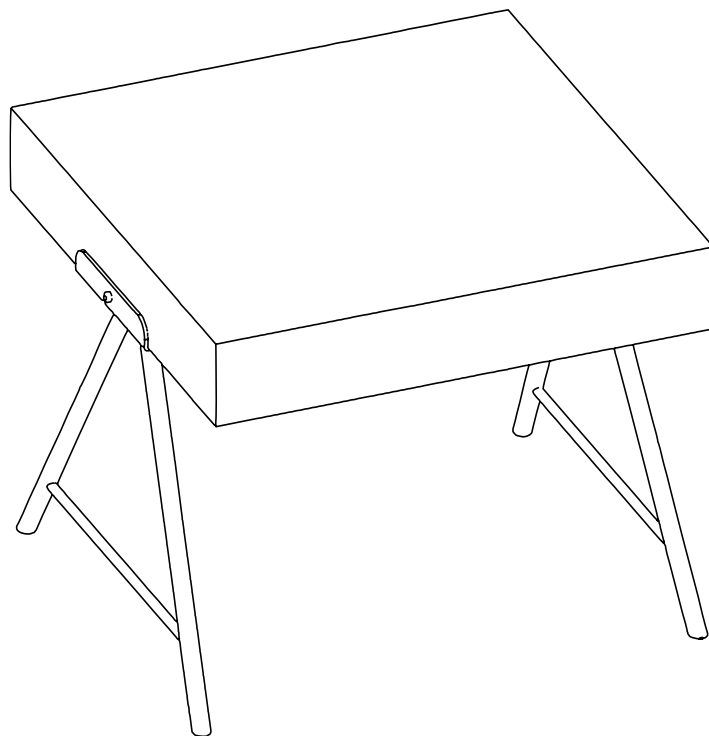

Assembly Instructions

Caution : You must read this before you proceed

End Table





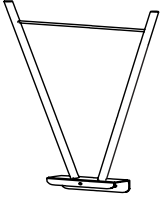
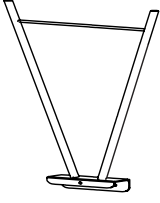

Parts List

Label	Picture	Description	QTY
A		Top	1

B		Lege(R)	1
C		Lege(L)	1

Hardware

Label	Picture	Description	QTY
①		Washer	7
②		Lock Washer	7
③		Allen Screw	7
④		Allen Key	1

Assembly Preparation

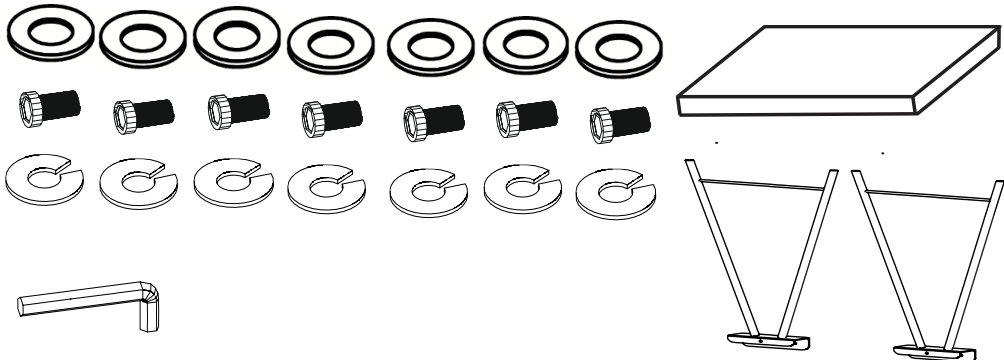
<p>Before Beginning Assembly:</p>	
-----------------------------------	--



- Read instructions, cover to cover-



- Have 2 adults on hand for assembly-



- Do not assemble on flooring or carpet-



- Assemble on a clean non-marring surface (packing foam)-



- Save all packaging until finished-

Assembly Steps

Overview

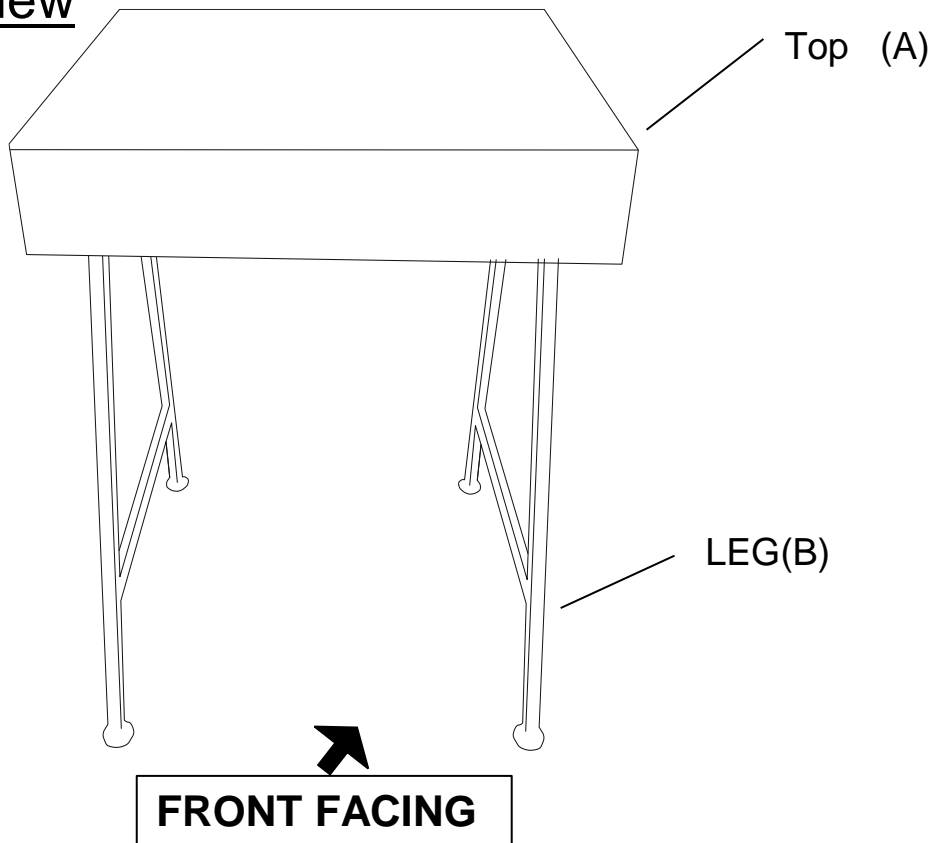

This Round Table has multiple parts and may require up to 30 minutes to assemble. To give you an overview of the Round Table parts, the above picture is to help you put the various parts into perspective. Please read through the instructions herebelow to familiarise the parts and steps before assembly.

Step 1

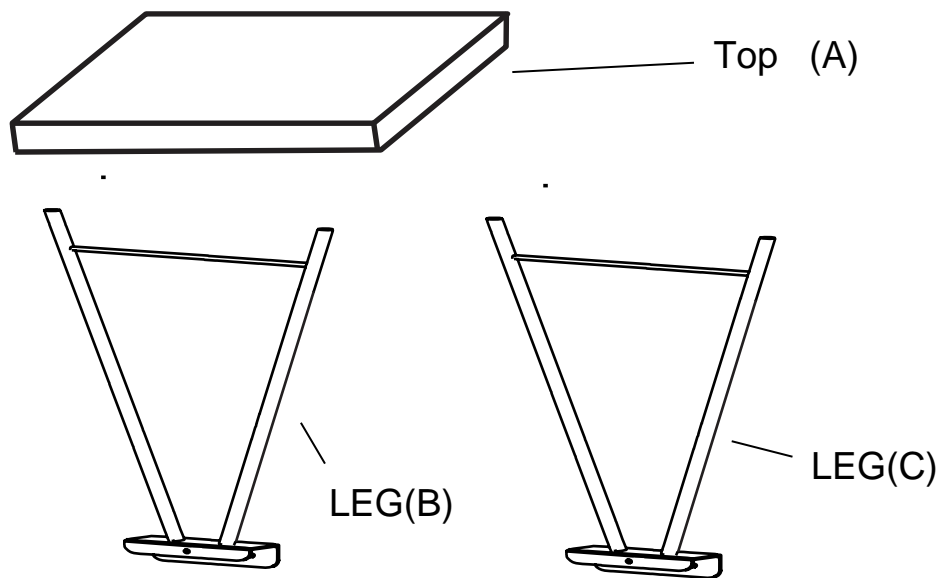

Unpack and place all parts on a clean, non-marring surface.

Step 2

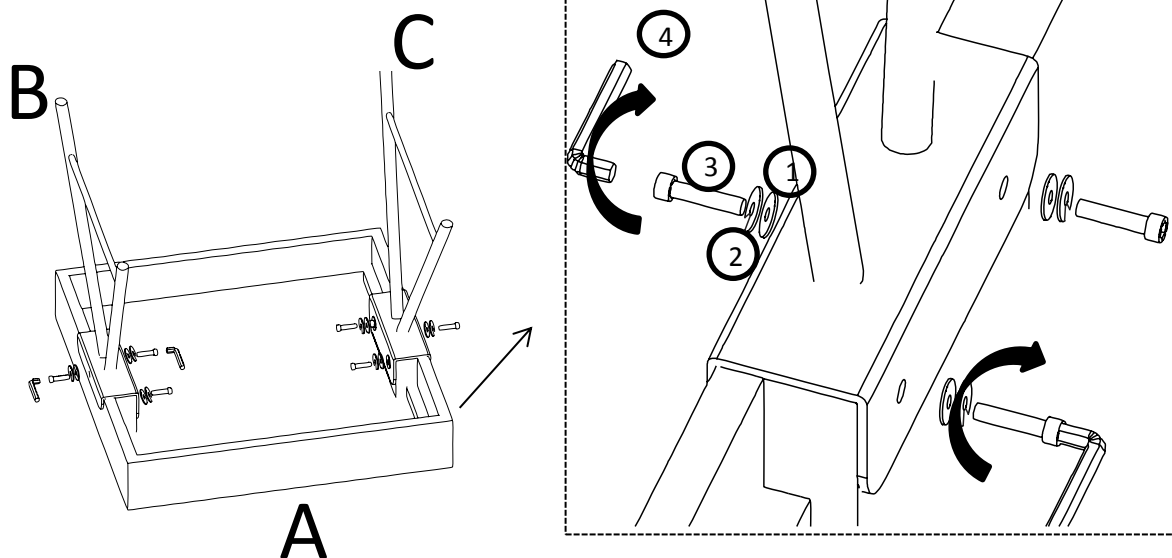

Place the Top (A) upside down onto a clean, soft surface to avoid any scratches or damages to the product. Align the holes of Top Panel (A) into All legs (B) as shown above. Then, affix the Top Panel (A) with legs (B) by using Washer (①), Lock Washer (②), Allen Screw (③) with help of Allen key (④).

Step 3

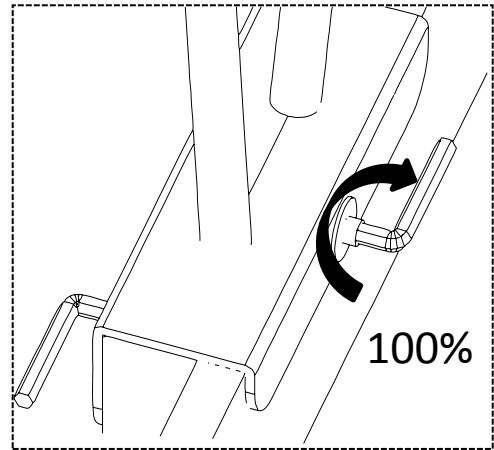
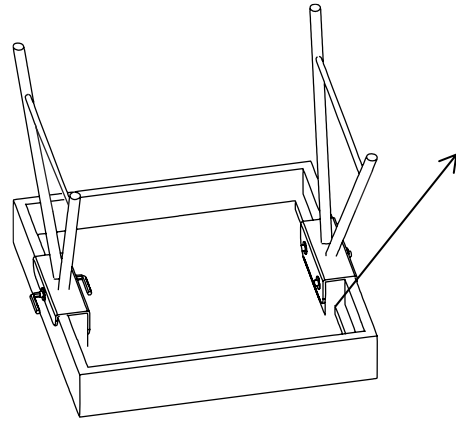

Tighten all the screws 100% with the help of Allen key (4).

Step 4



ROTATE THE PIECE UPSIDE DOWN.
This End table is now ready to use. Caution.
This End Table can only be used on a flat, level surface.

Care & Maintenance



- Furniture may scratch floors. We recommend using furniture pads to protect your floors.



- Do not put hot items directly on furniture surface.



- Do not clean furniture with harsh cleansers or polish.



- Do not place furniture under direct sunlight.



- Do not place furniture near heating or cooling vents.



- Do not write on furniture without a padded barrier to protect the surface.



- Do not place furniture outside . For indoor use only.



- Not for commercial use. For residential use only.



- Stains may be removed with mild soap solution and damp cloth.



- Children should not climb or jump on the furniture.



- Dust and pick-up spills using a clean, non-colored, lint-free cloth.