

# *ASSEMBLY INSTRUCTIONS*



# ASSEMBLY INSTRUCTIONS

## ASSEMBLY TIPS:

1. Remove hardware from box and sort by size.
2. Please check to see that all hardware and parts are present prior to start of assembly.
3. Please follow attached instructions in the same sequence as numbered to assure fast & easy assembly.



### WARNING!

1. Don't attempt to repair or modify parts that are broken or defective. Please contact the store immediately.
2. This product is for home use only and not intended for commercial establishments.



ASSEMBLY TIME

60 MINUTES

MAX TV SIZE : 85"

## PARTS IDENTIFICATION

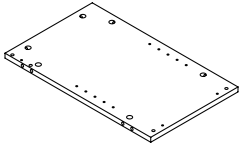
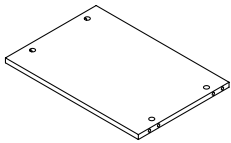
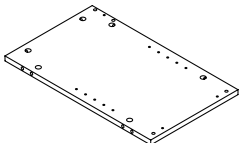
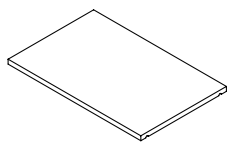
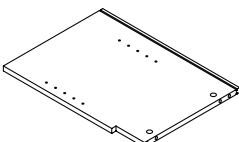
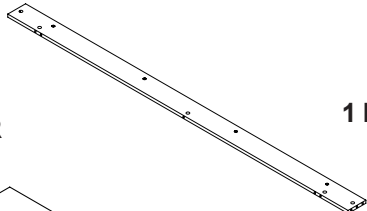
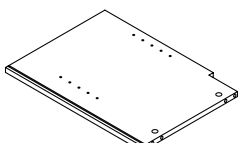
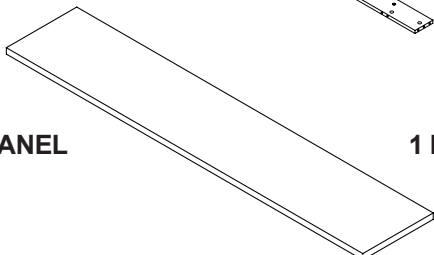
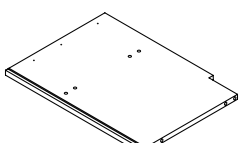
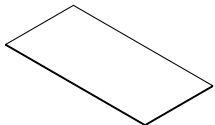
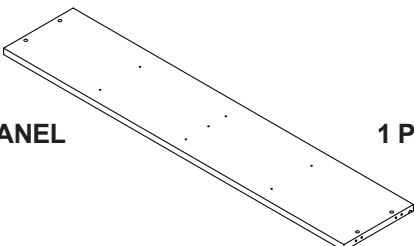
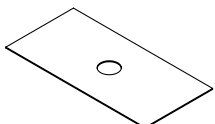
A	LEFT SIDE PANEL		1 PC	G	CROSS PANEL		2 PCS
B	RIGHT SIDE PANEL		1 PC	H	ADJUSTABLE SHELF		2 PCS
C	LEFT DIVIDER PANEL		1 PC	I	UPPER CROSSBAR		1 PC
D	RIGHT DIVIDER PANEL		1 PC	J	TOP PANEL		1 PC
E	MIDDLE DIVIDER PANEL		1 PC	K	BACK PANEL		6 PCS
F	BOTTOM PANEL		1 PC	L	MIDDLE BACK PANEL		2 PCS

### NOTE:



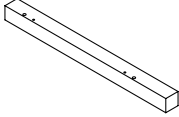
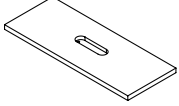
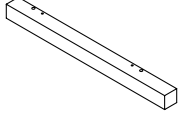
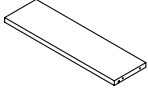
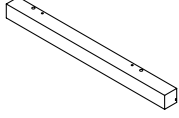
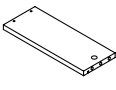
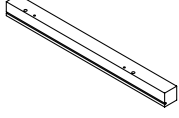
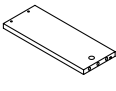
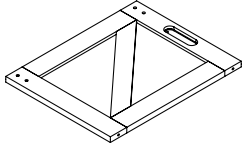
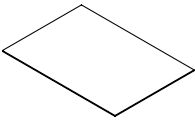
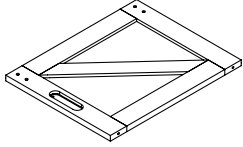
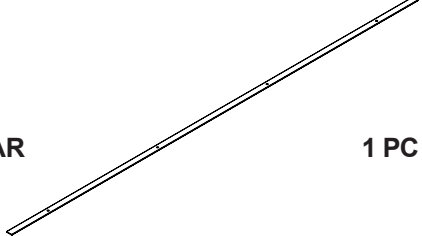







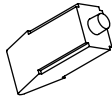
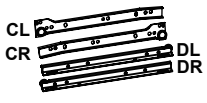
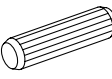

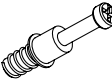
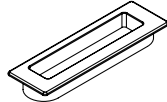

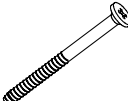
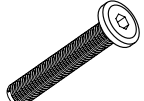
Phillips head screw driver is required in the assembly process; however, manufacturer does not provide this item.

M	LEG 1		1 PC	S	DRAWER FRONT PANEL		2 PCS
N	LEG 2		1 PC	T	DRAWER BACK PANEL		2 PCS
O	LEG 3		1 PC	U	DRAWER LEFT SIDE PANEL		2 PCS
P	LEG 4		1 PC	V	DRAWER RIGHT SIDE PANEL		2 PCS
Q	LEFT DOOR		1 PC	A1	DRAWER BOTTOM PANEL		2 PCS
R	RIGHT DOOR		1 PC	A2	TRACK BAR		1 PC

**NOTE:**

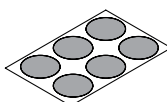
Phillips head screw driver is required in the assembly process; however, manufacturer does not provide this item.

## HARDWARE IDENTIFICATION

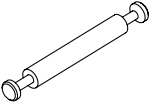
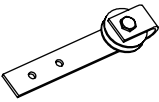



Z							
NO	DESCRIPTION	FIGURE	Q'TY	NO	DESCRIPTION	FIGURE	Q'TY
1	GLUE 40g		1 PC	12	GLIDES L = 300mm BLK		2 SET
2	WOODEN DOWEL Ø8x30mm		46 PCS	13	GLIDES SCREW Ø3x10mm BLK		24 PCS
3	CAM BOLT Ø7x35.5mm SR		35 PCS	14	HANDLE L=115mm BLK		4 PCS
4	CAM LOCK Ø15x12mm SR		39 PCS	15	HANDLE BOLT Ø4x13mm BLK		8 PCS
5	BOLT Ø9.5x55mm SR		7 PCS	16	BOLT M6x43mm BLK		4 PCS
6	SCREW Ø4.3x35mm SR		8 PCS	17	BOLT M6x19mm BLK		8 PCS
7	PIN FOR ADJUSTABLE SHELF Ø4.9x15mm SR		8 PCS	18	ALLEN WRENCH 4mm SR		1 PC
8	PIN Ø5.8x25mm SR		4 PCS	19	STICKER Ø20mm		7 PCS
9	PLASTIC FEET Ø15mm		5 PCS	20	SQUARE FOOT		1 PC
10	WOODEN DOWEL Ø8x50mm		2 PCS	21	TRACK SPACER Ø25x25mm BLK		4 PCS
11	CAM BOLT Ø7x63mm SR		2 PCS	22	ROLLER Ø40.5x160mm BLK		4 PCS

**Z12,Z14,Z15,Z20,Z21,Z22 not included in blister packaging.**

**NOTE:**

Phillips head screw driver is required in the assembly process; however, manufacturer does not provide this item.

# STEP 1

- |  |   |
|--|---|
|  <b>2</b><br>x 6  |  <b>3</b><br>x 7 |
|  <b>4</b><br>x 6  |  <b>9</b><br>x 2 |
|  <b>19</b><br>x 4 |   |

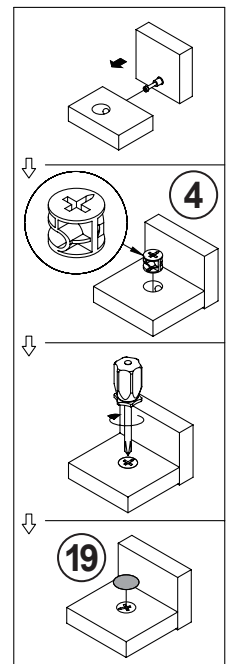
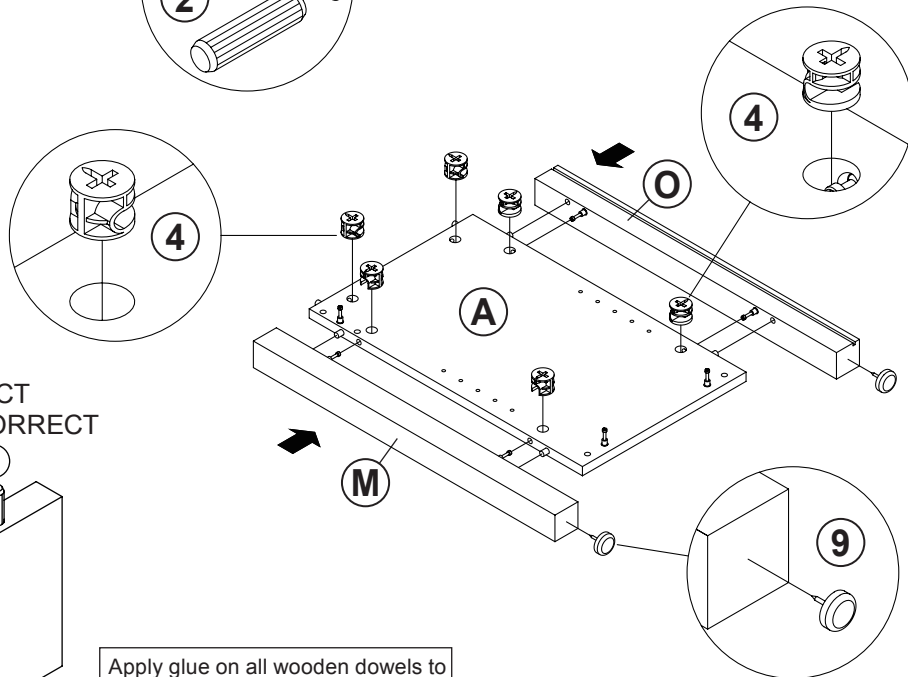
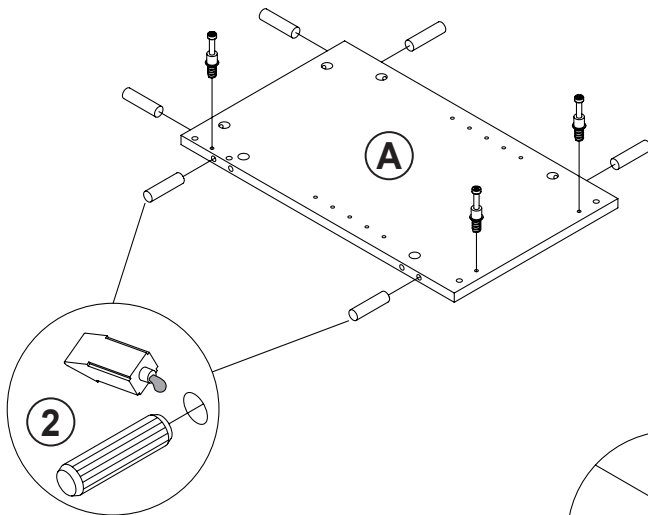
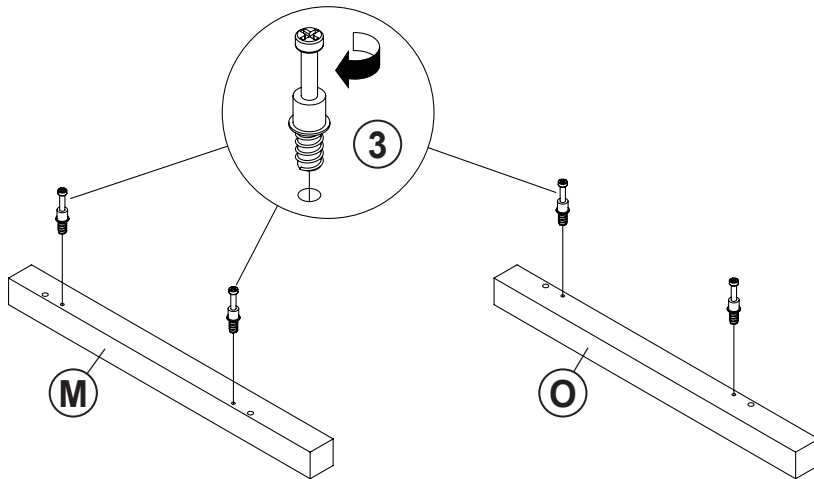



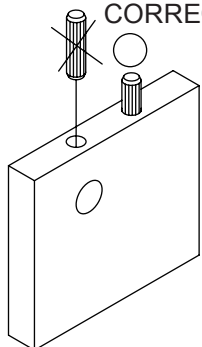



INCORRECT  
CORRECT

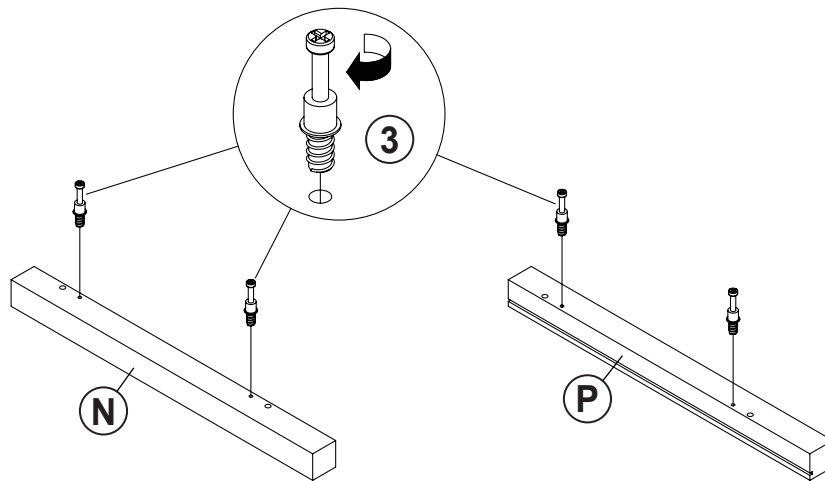





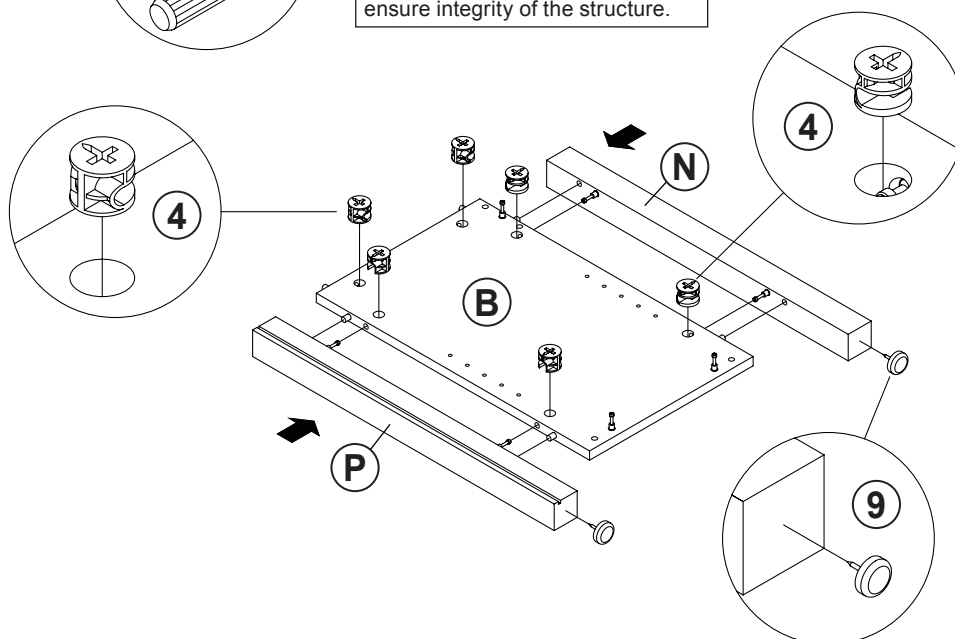
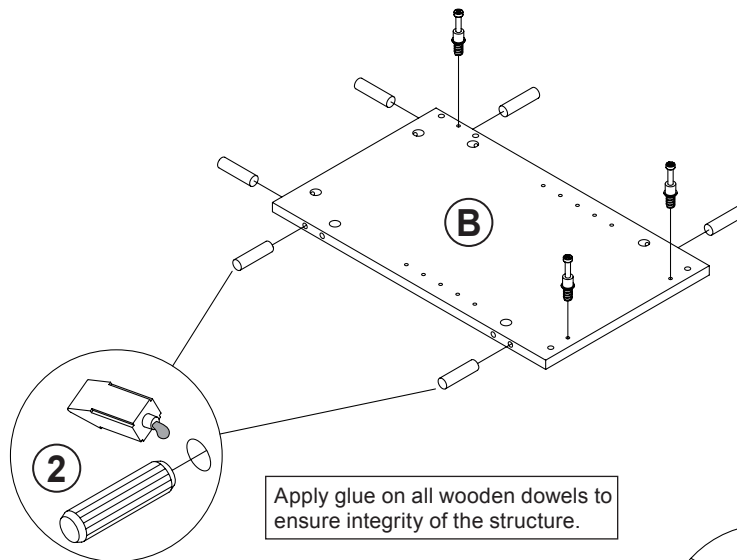

Apply glue on all wooden dowels to ensure integrity of the structure.

# STEP 2



- |  |   |
|--|---|
|  <b>2</b><br>x 6  |  <b>3</b><br>x 7 |
|  <b>4</b><br>x 6  |  <b>9</b><br>x 2 |
|  <b>19</b><br>x 4 |   |

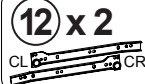

- |   |  |
|---|--|
|  <b>2</b><br>x 12  |  <b>3</b><br>x 4        |
|  <b>4</b><br>x 6   |  <b>12 x 2</b><br>CL CR |
|  <b>13</b><br>x 12 |  |

the reverse side

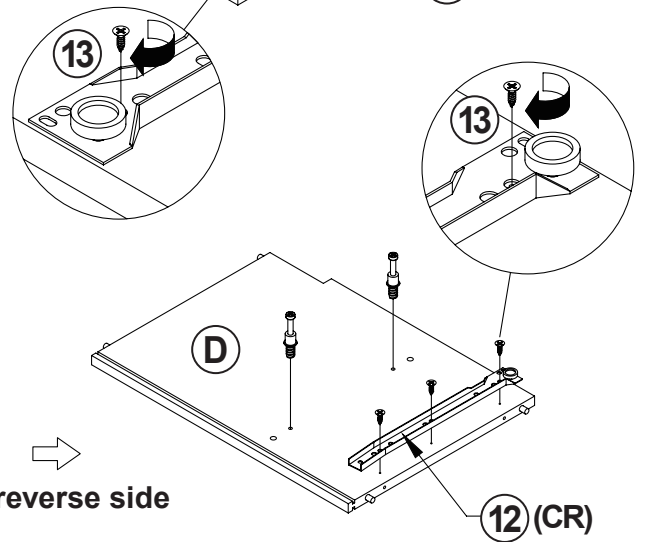
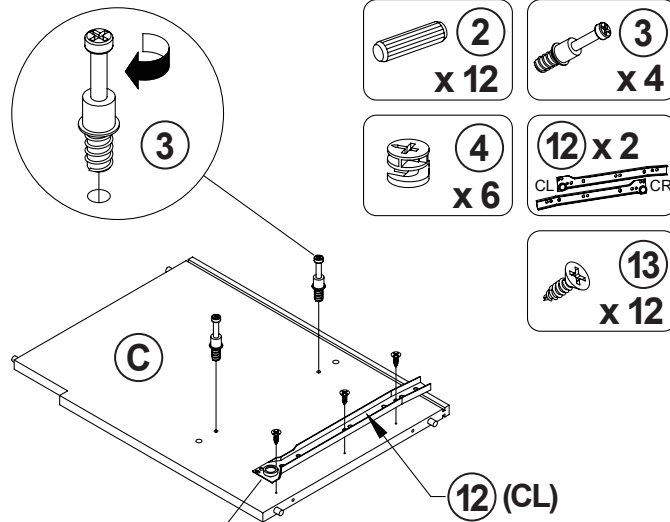
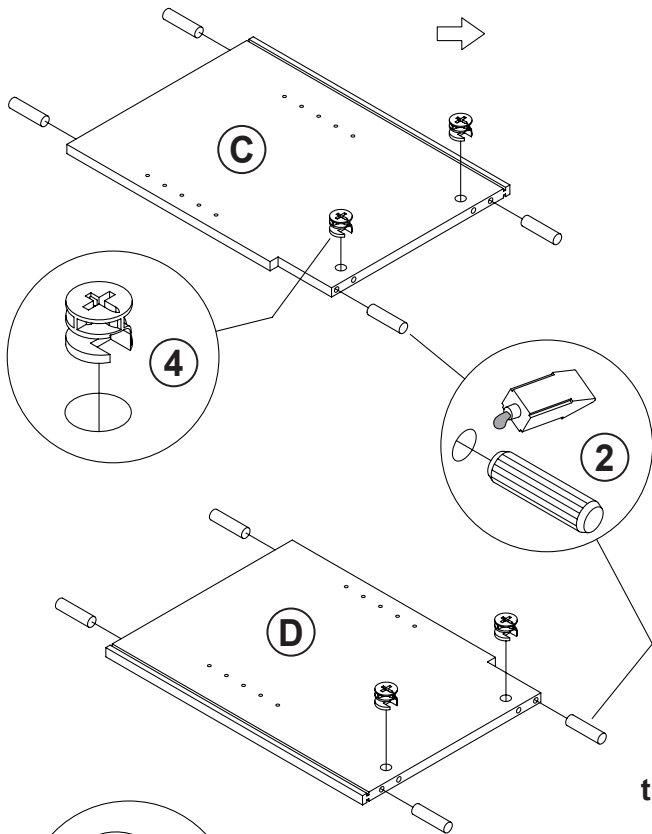

the reverse side

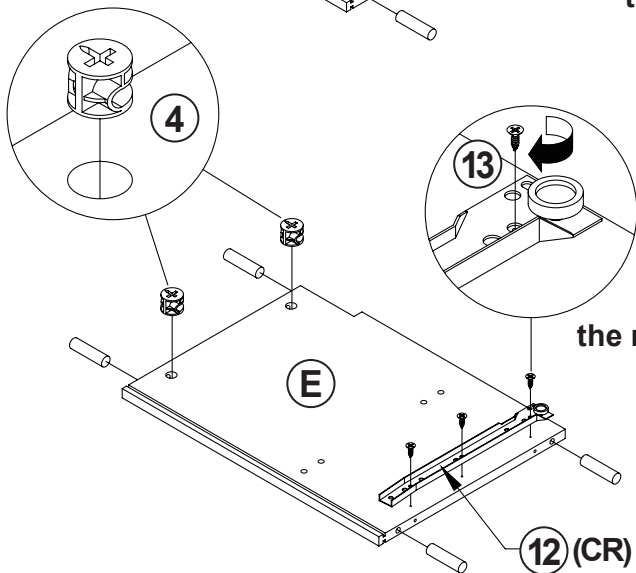

the reverse side

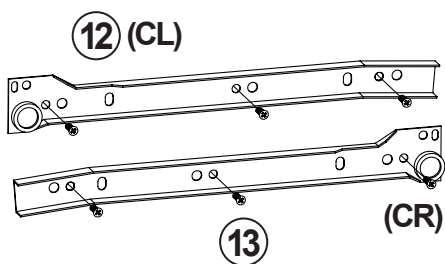
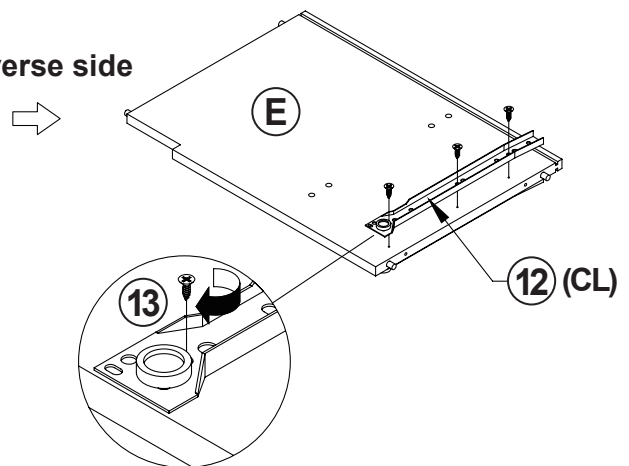

Apply glue on all wooden dowels to ensure integrity of the structure.

# STEP 4

Apply glue on all wooden dowels to ensure integrity of the structure.

- 2 x 8
- 3 x 13
- 4 x 12
- 5 x 1
- 9 x 1
- 10 x 2
- 20 x 1

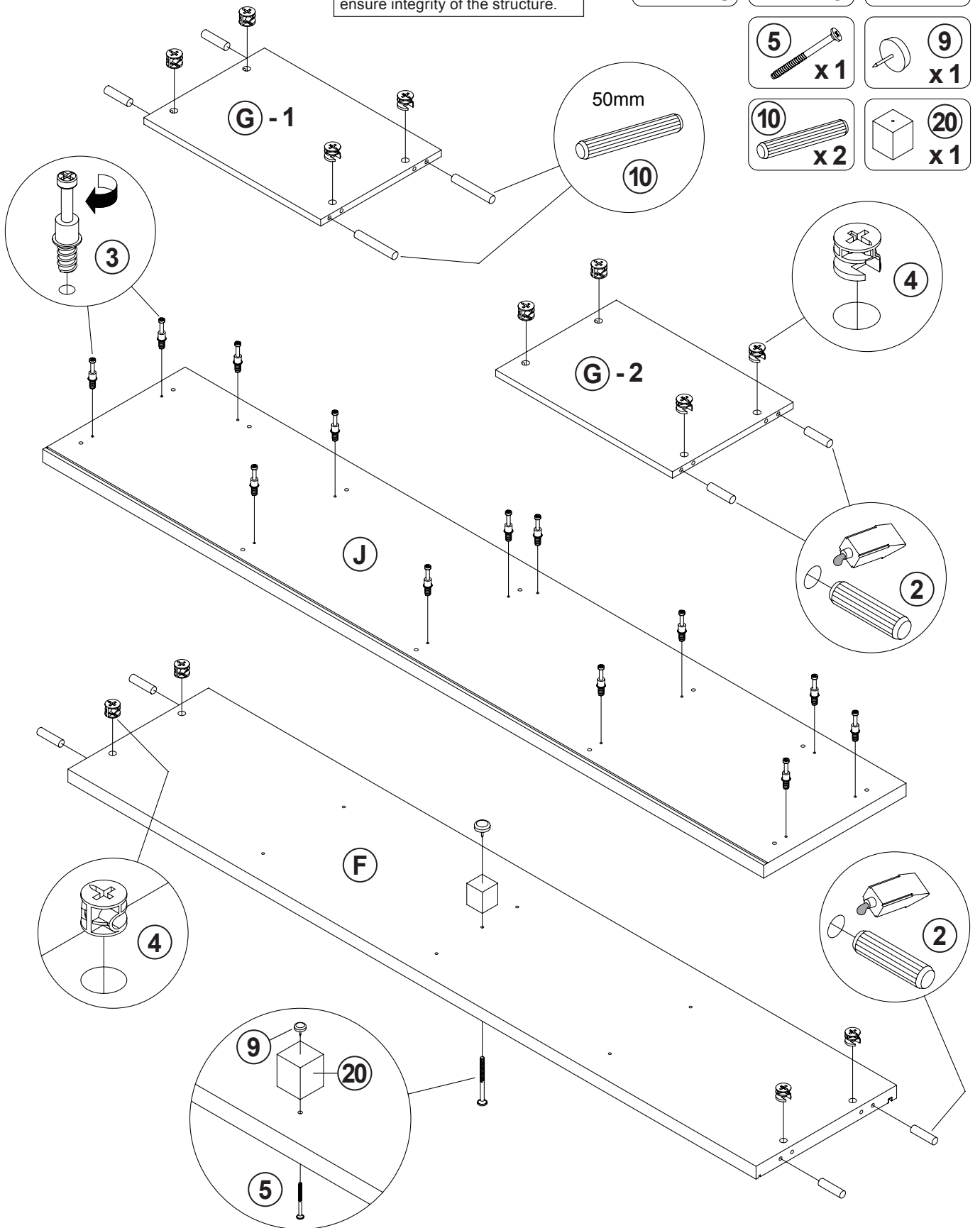

## STEP 5

the reverse side

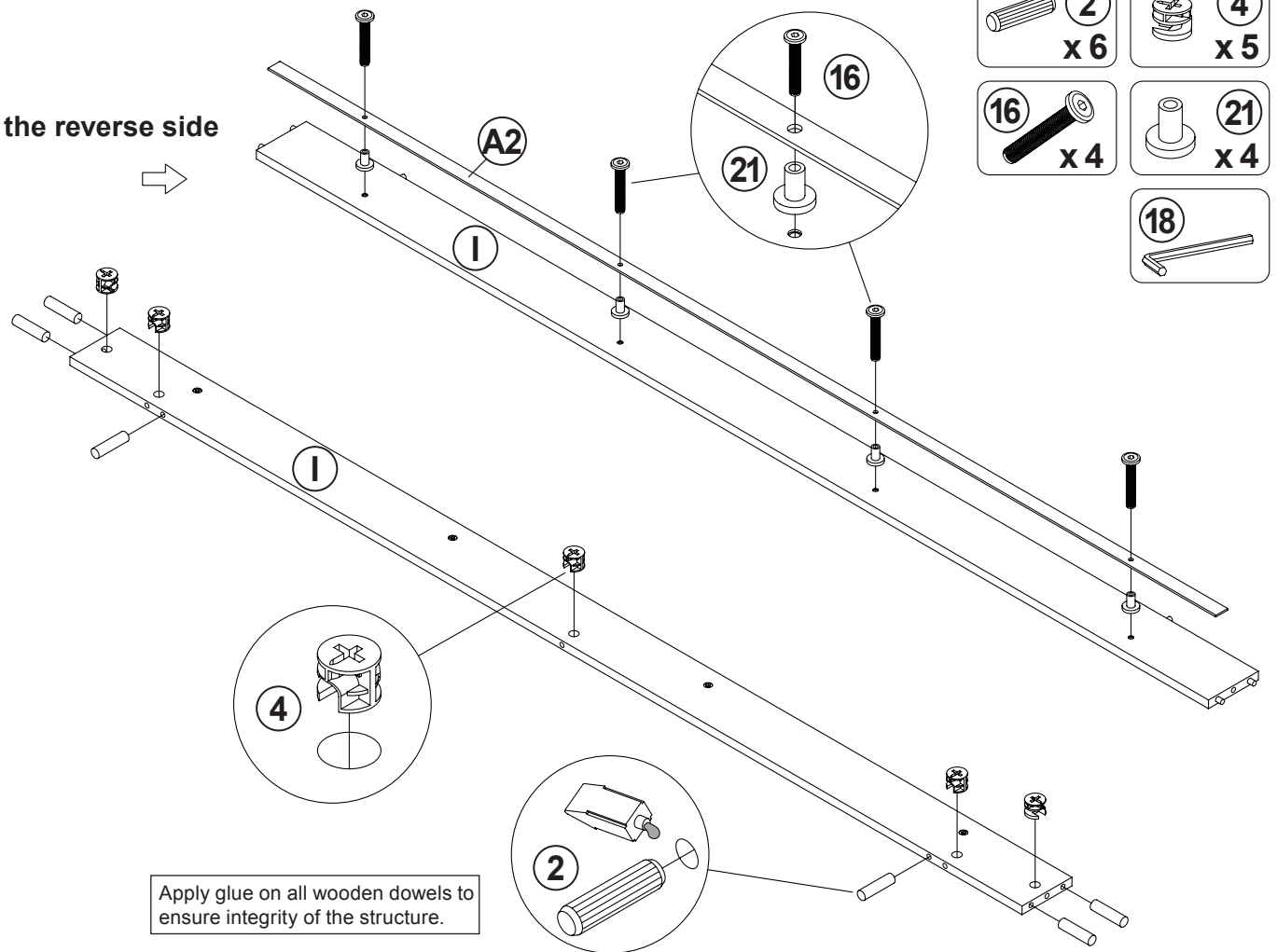

## STEP 6

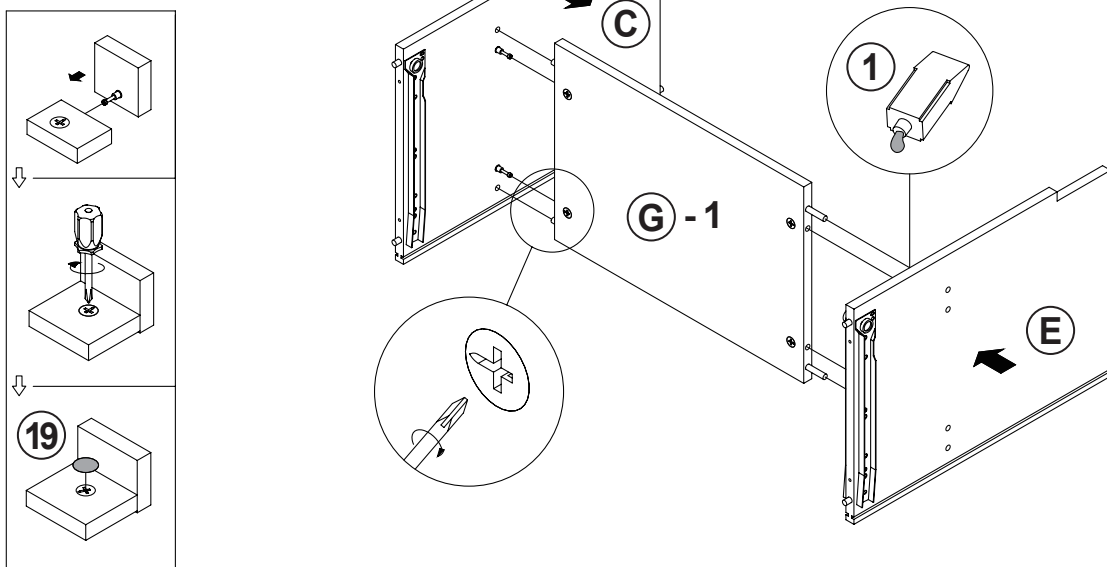
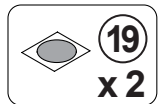

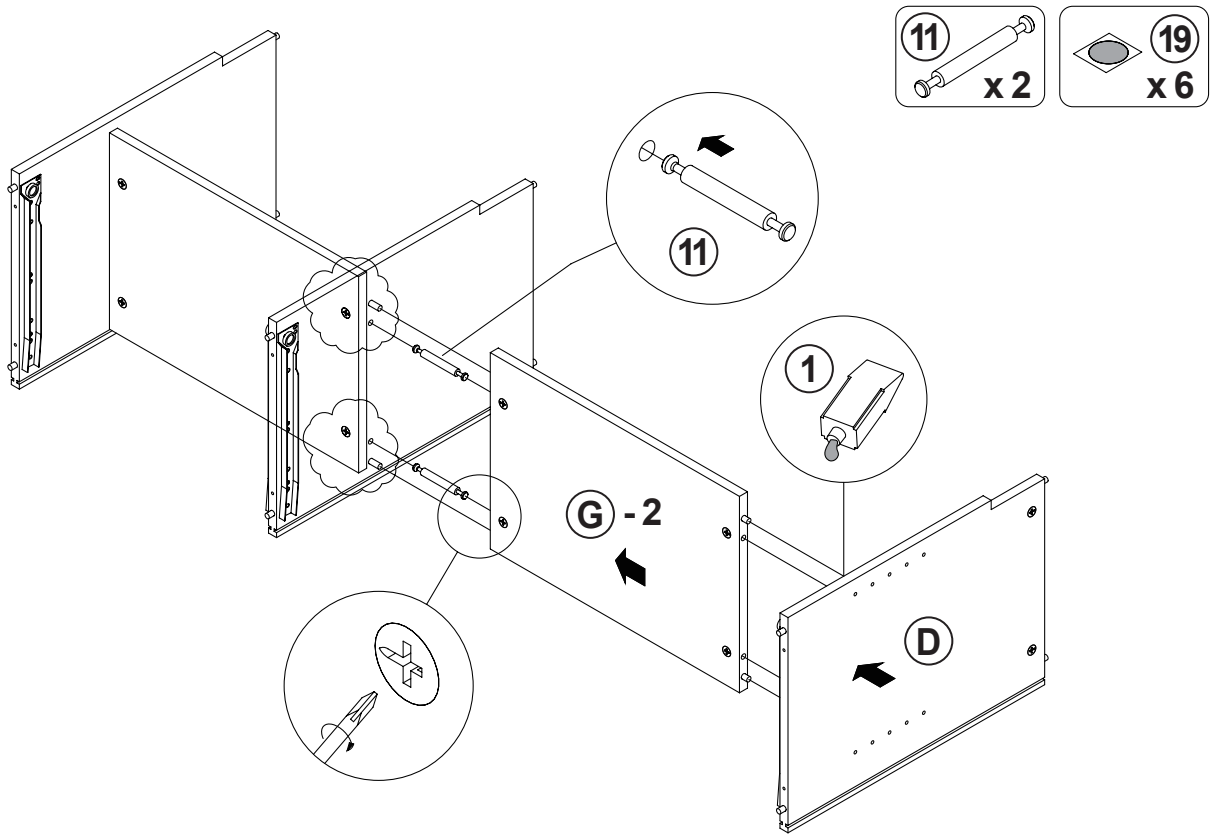

## STEP 8

Apply glue on all wooden dowels to ensure integrity of the structure.

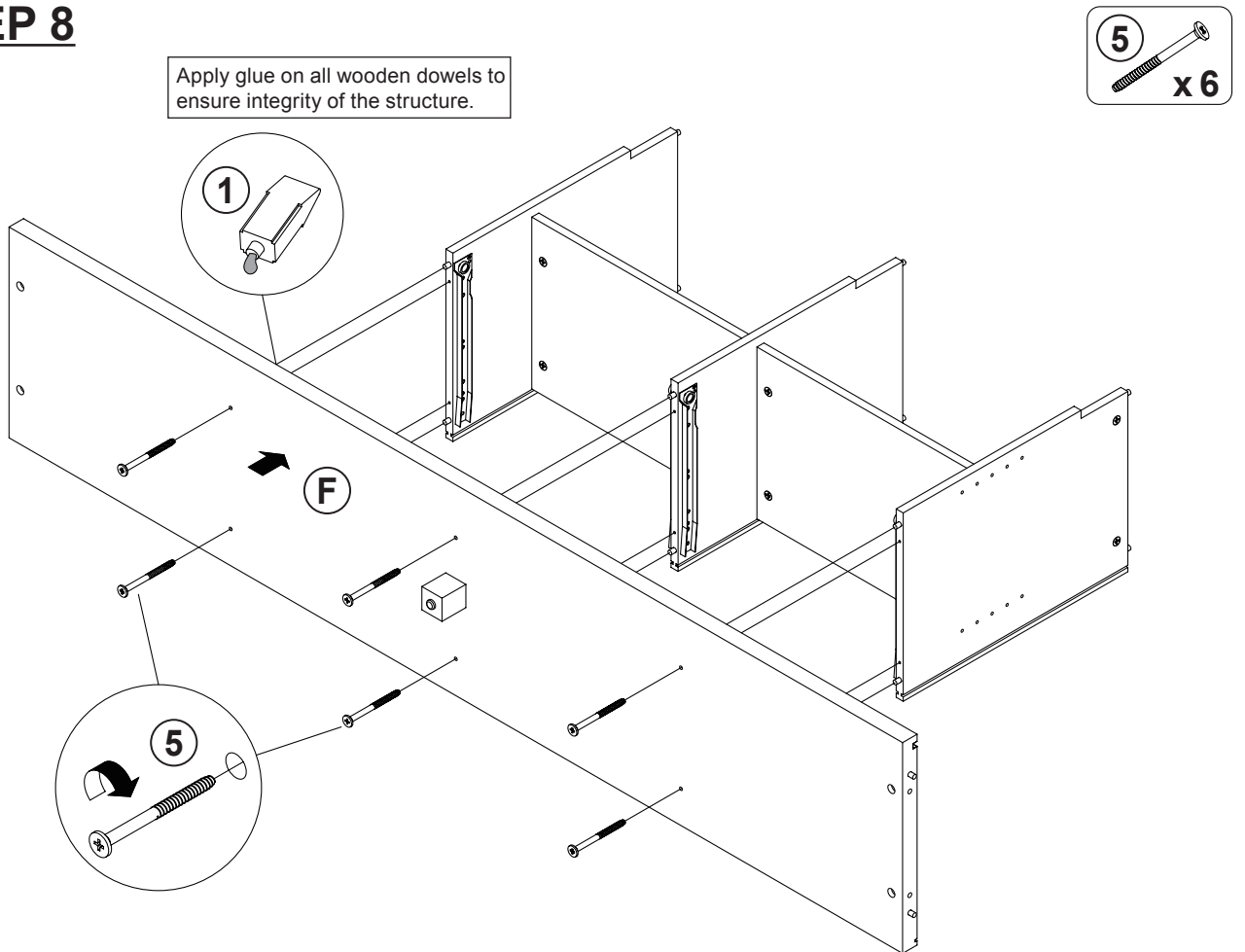

## STEP 9

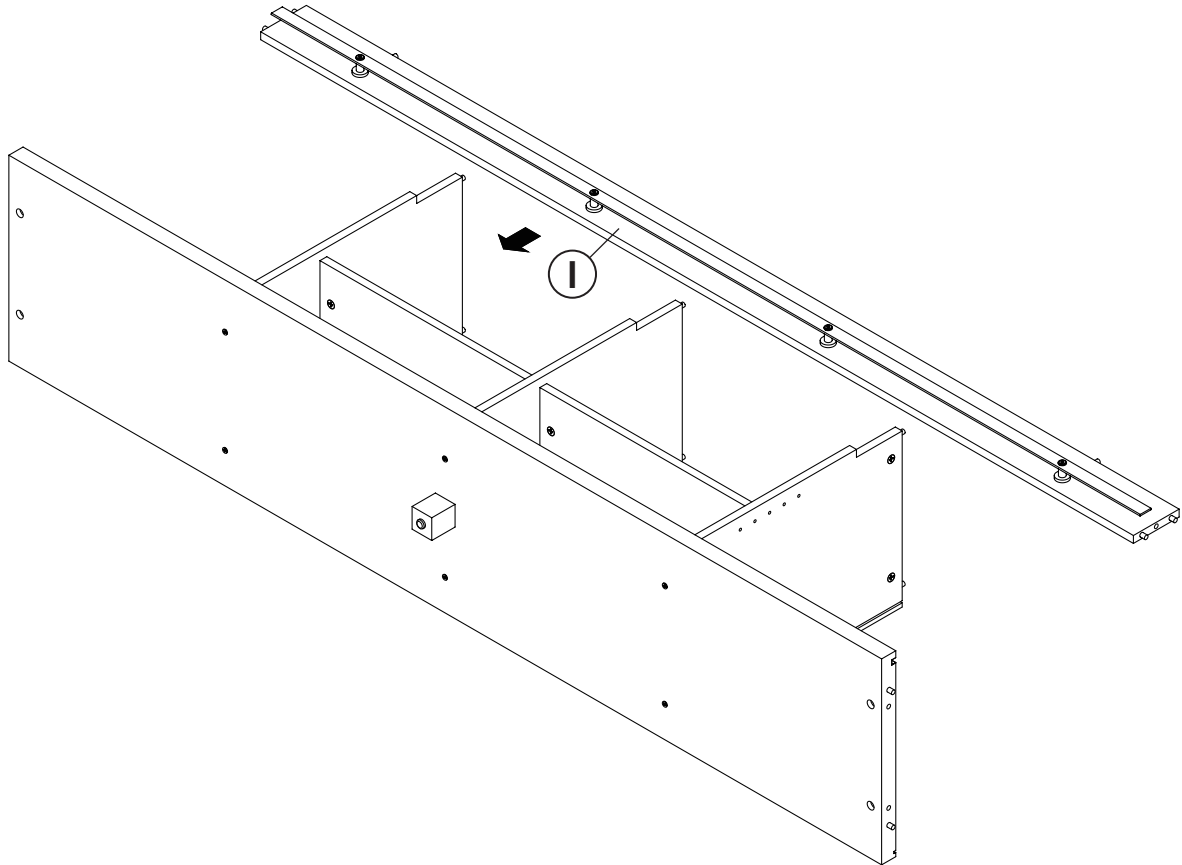

## STEP 10

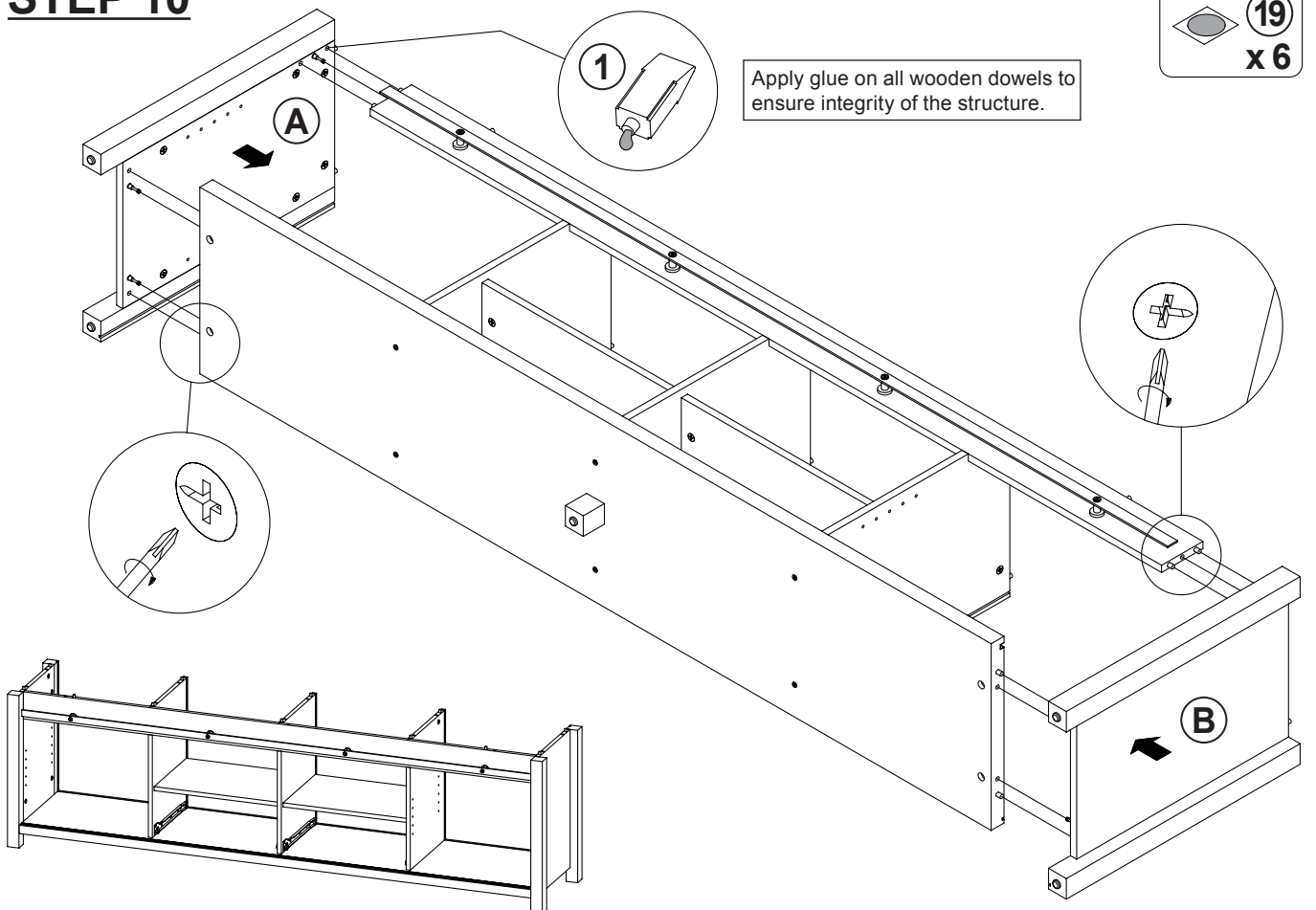

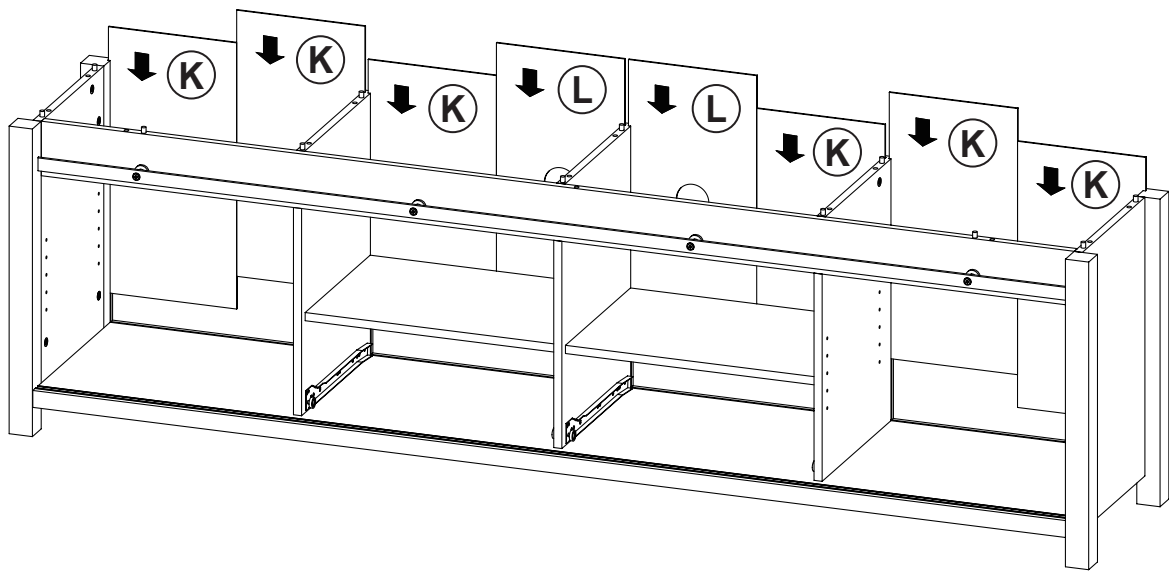

## **STEP 12**

 **19**  
**x 13**

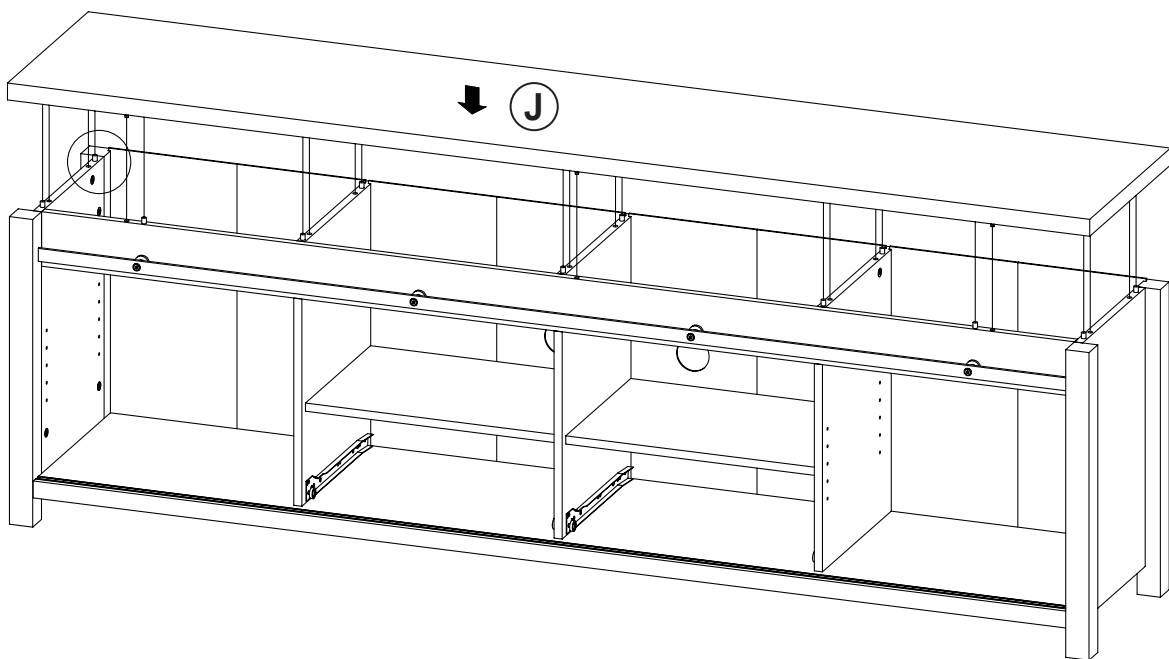
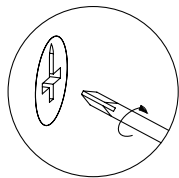

### STEP 13-1

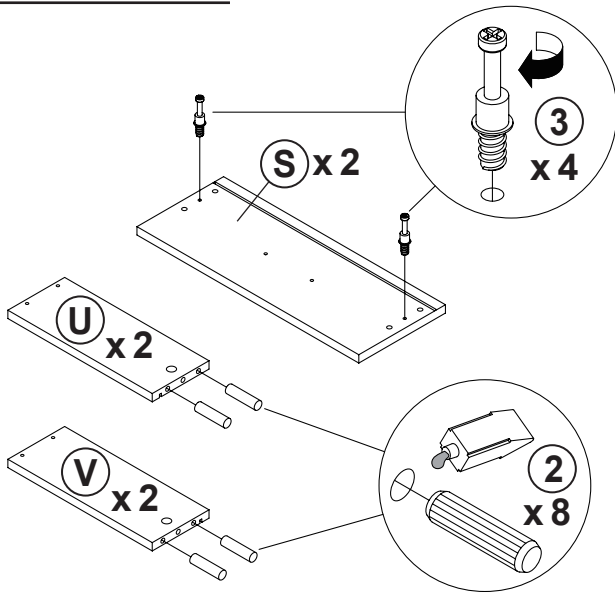

### STEP 13-2

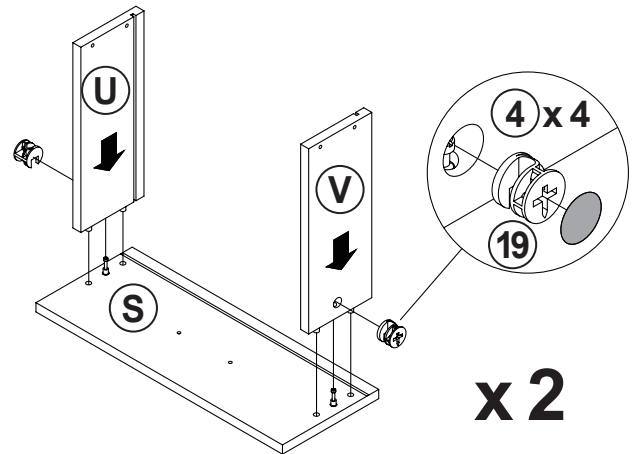

### STEP 13-3

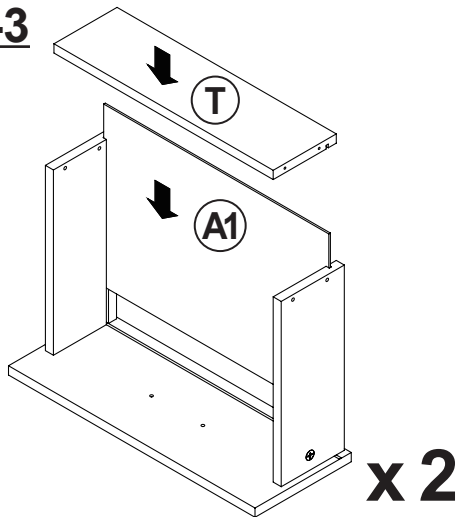

### STEP 13-4

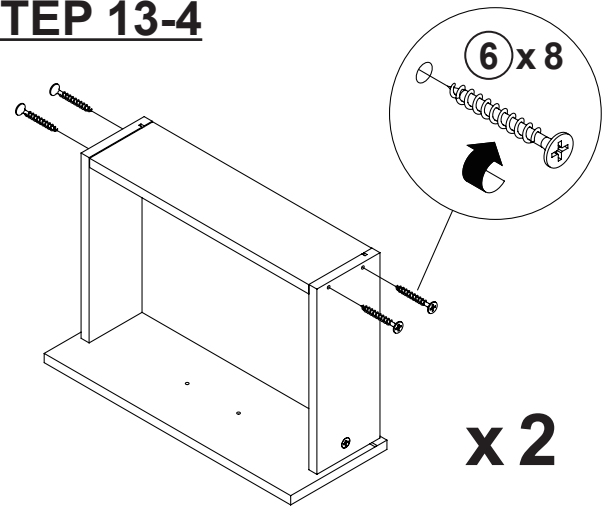

### STEP 13-5

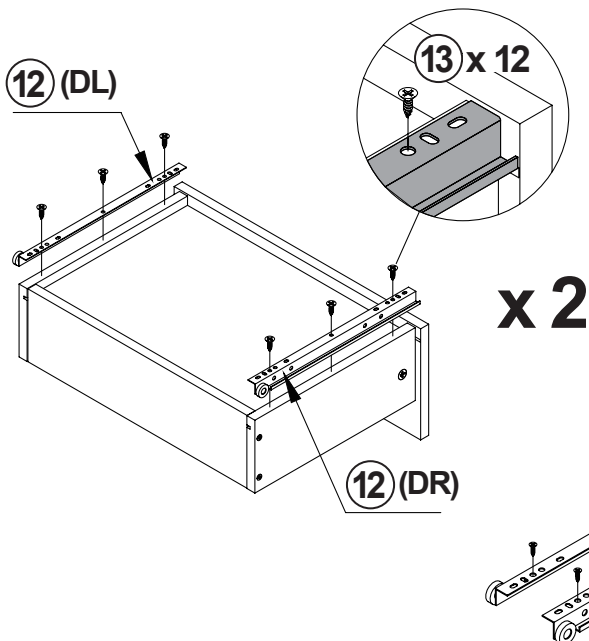

### STEP 13-6

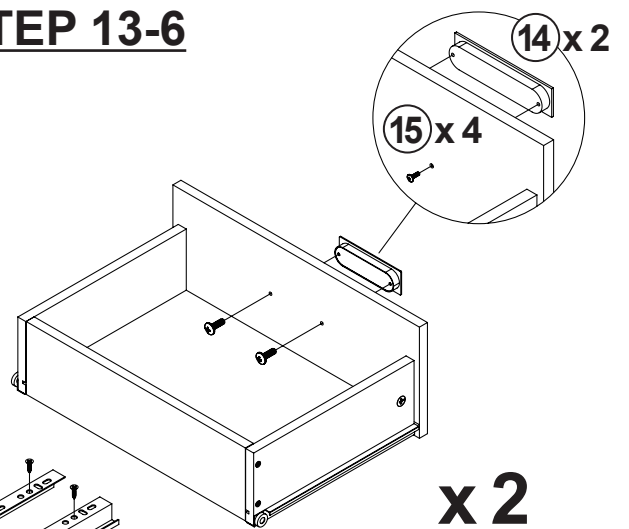

## STEP 14

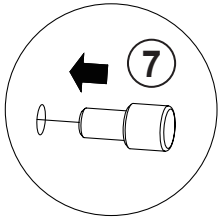
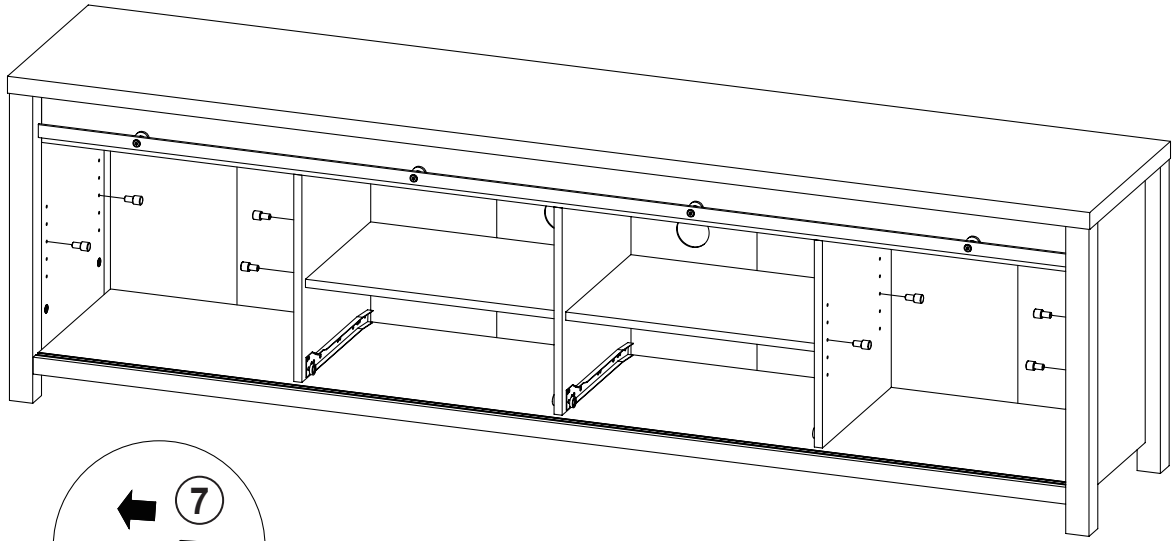
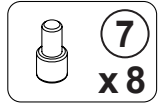

---

## STEP 15

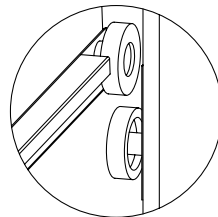
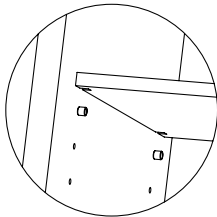
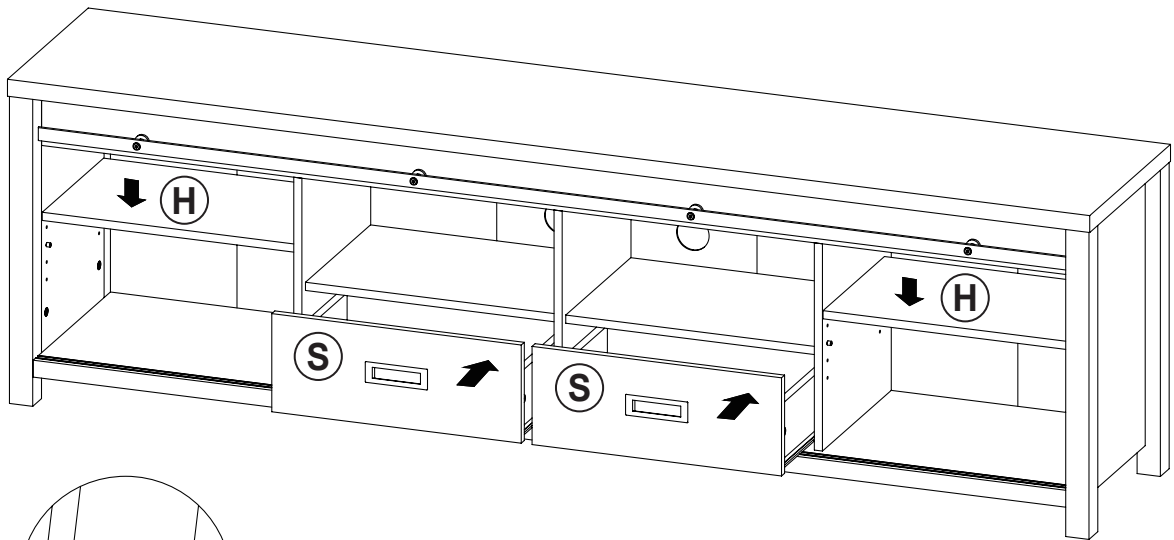

## STEP 16

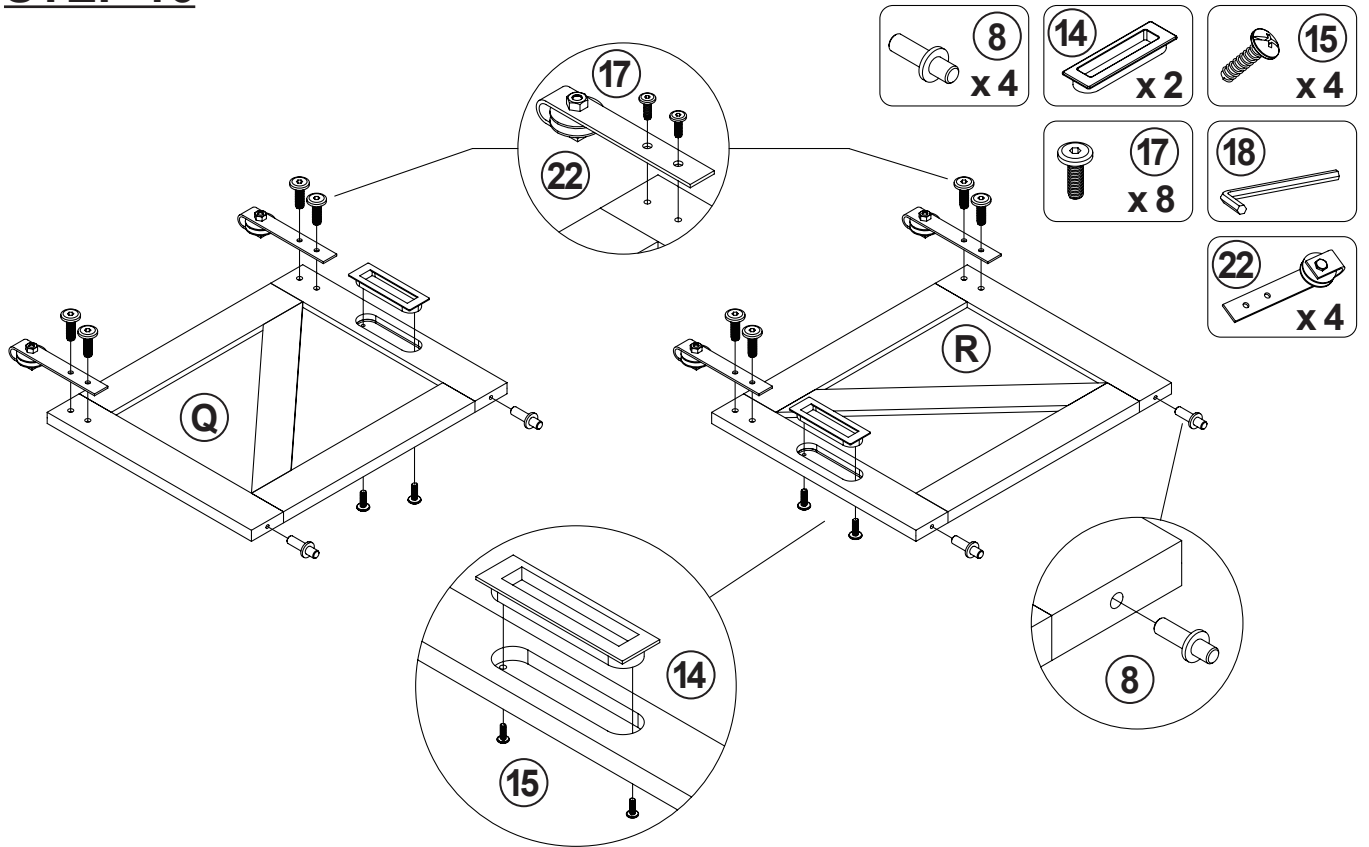

## STEP 17

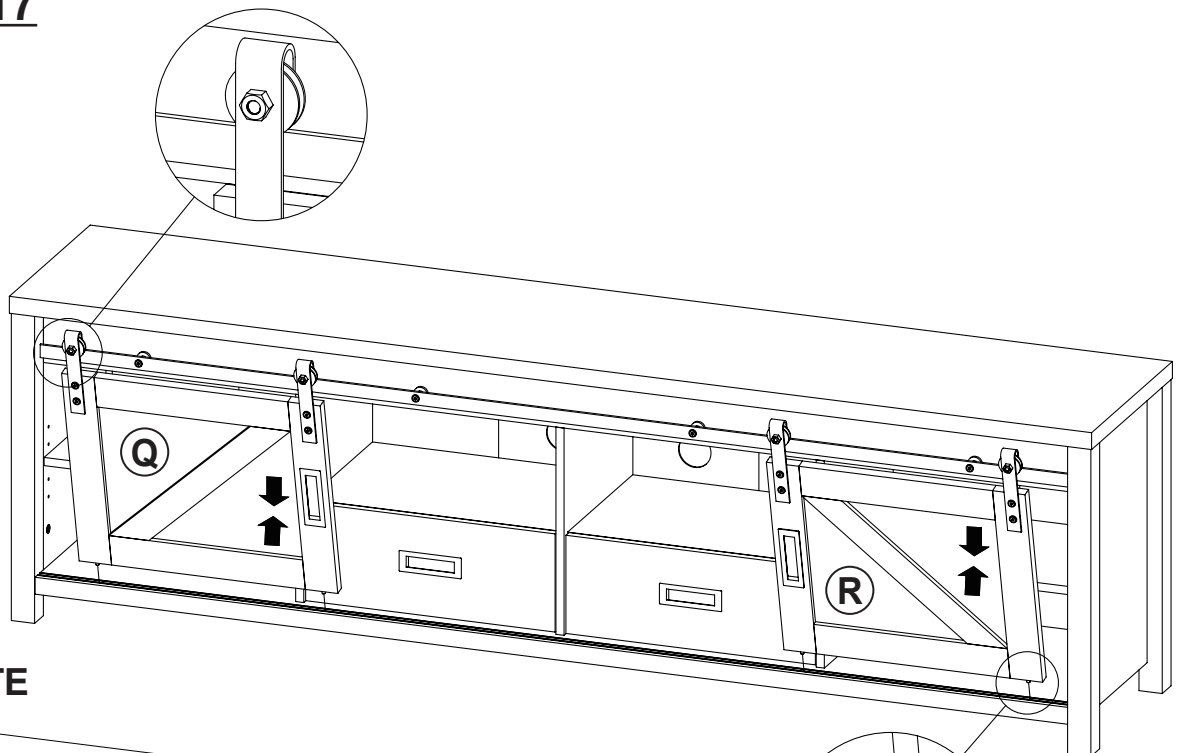

**COMPLETE**

