







ASSEMBLY INSTRUCTION

ACCENT CHAIR

NO.	PARTS LIST	QTY	DESCRIPTION	NO.	PARTS LIST	QTY	DESCRIPTION
A		1	Seat Frame	E		8	Flat Washer M8*Ø22*1.5mm
B		2	Wooden Rear Leg	F		8	Lock Washer M8
C		2	Wooden Front Leg	G		1	Allen Key M5*100*50mm
D		8	Allen Bolt ØM8*60				

STEP 1: Take all the parts from seat frame(A).

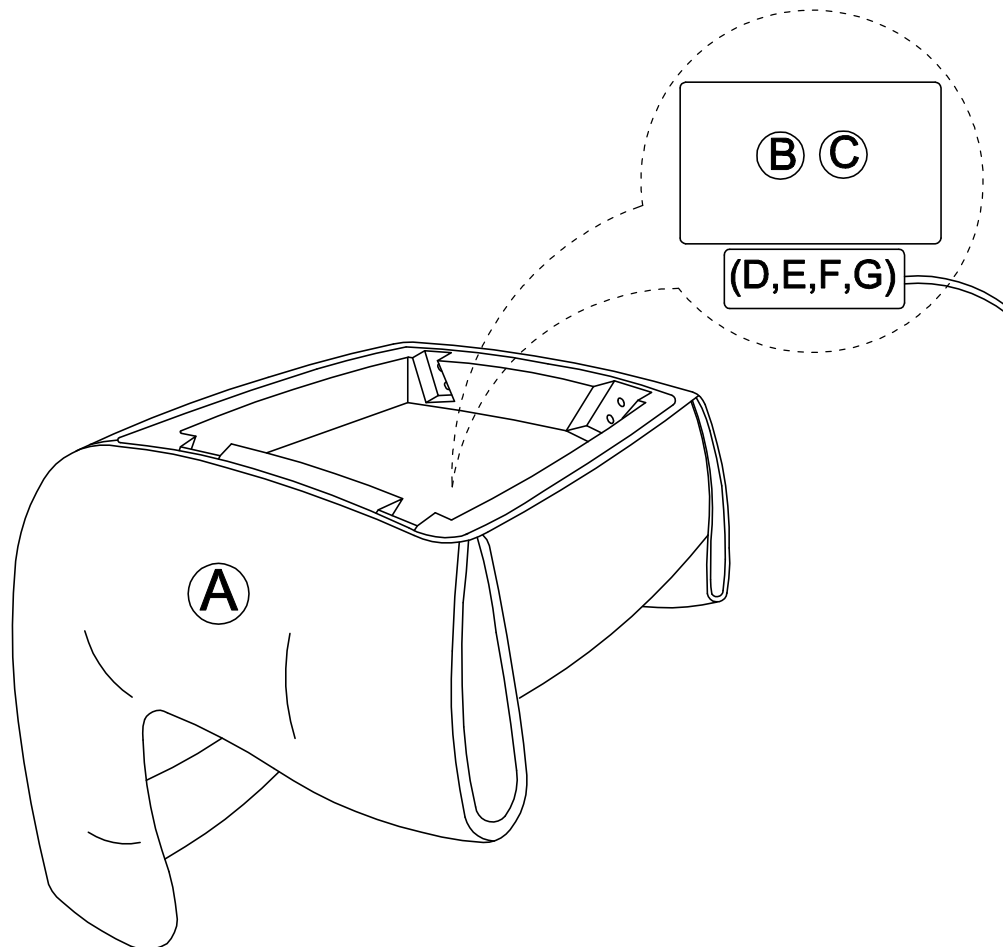

ASSEMBLY INSTRUCTION

ACCENT CHAIR

STEP 2: Insert Wooden Rear Leg(B) in to correct location.
Screw Lock Washer(F), Flat Washer(E), Allen Bolt(D), Allen Key(G).

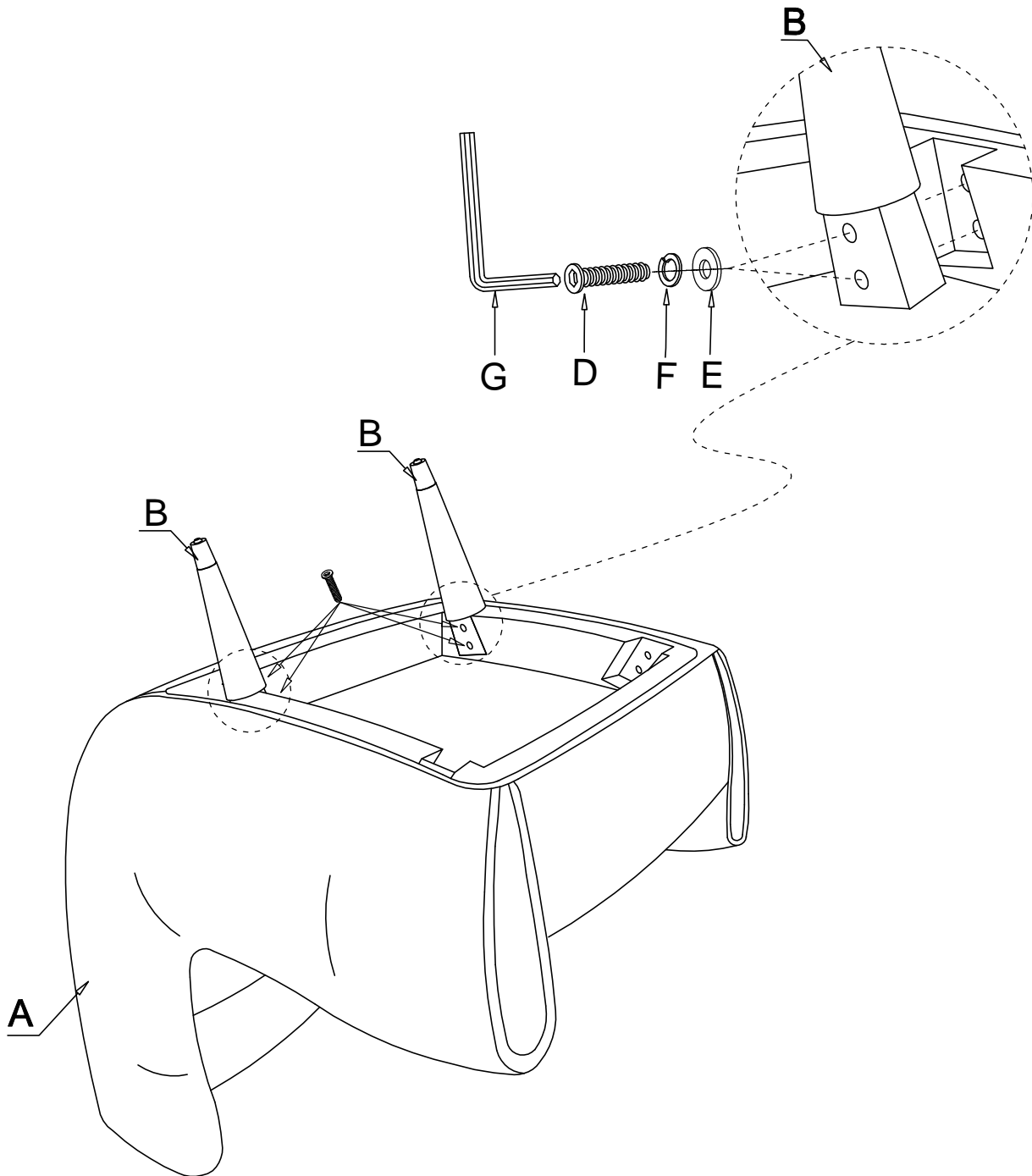

ASSEMBLY INSTRUCTION

ACCENT CHAIR

STEP 3: Insert Wooden Front Legs(C) in to correct location .
Screw Lock Washer(F), Flat Washer(E), Allen Bolt(D), Allen Key(G).

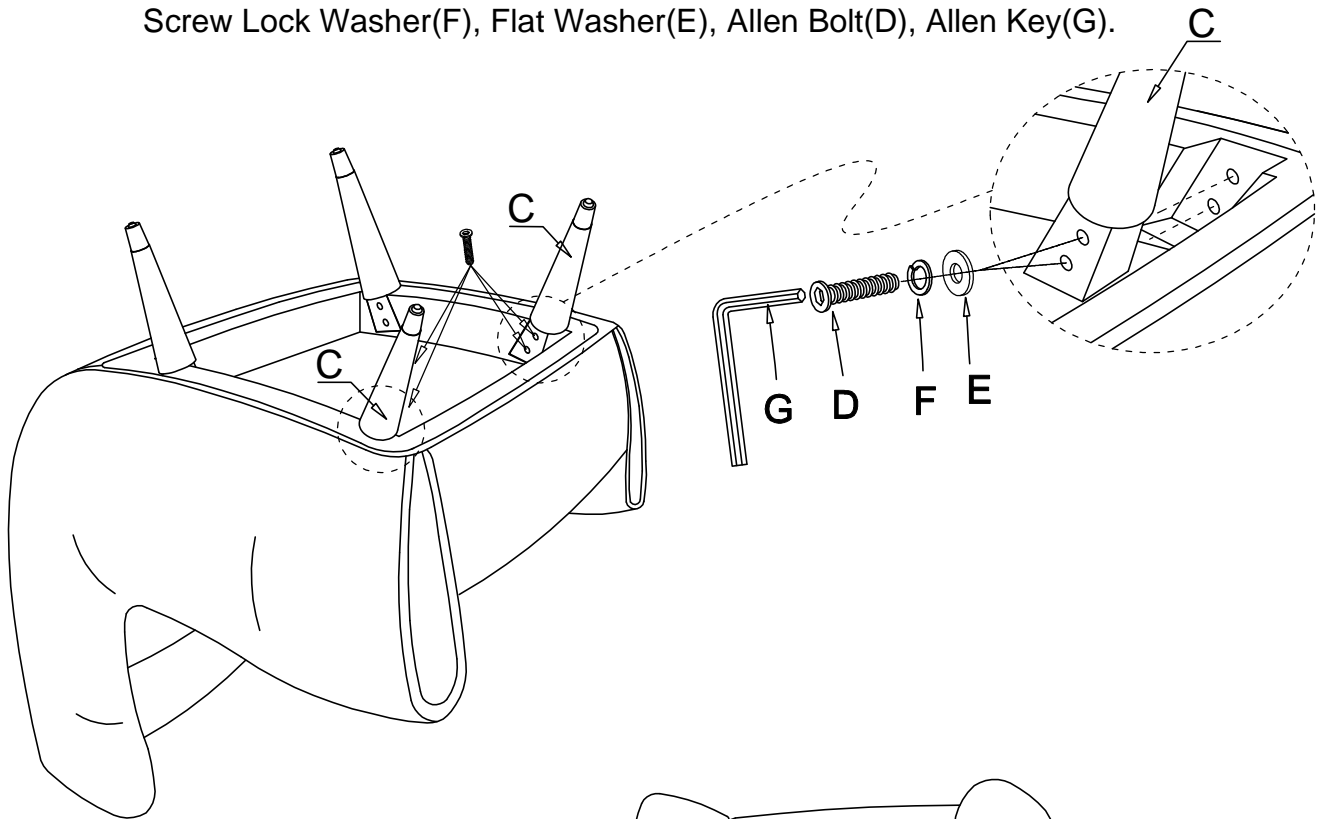

STEP 4: Complete

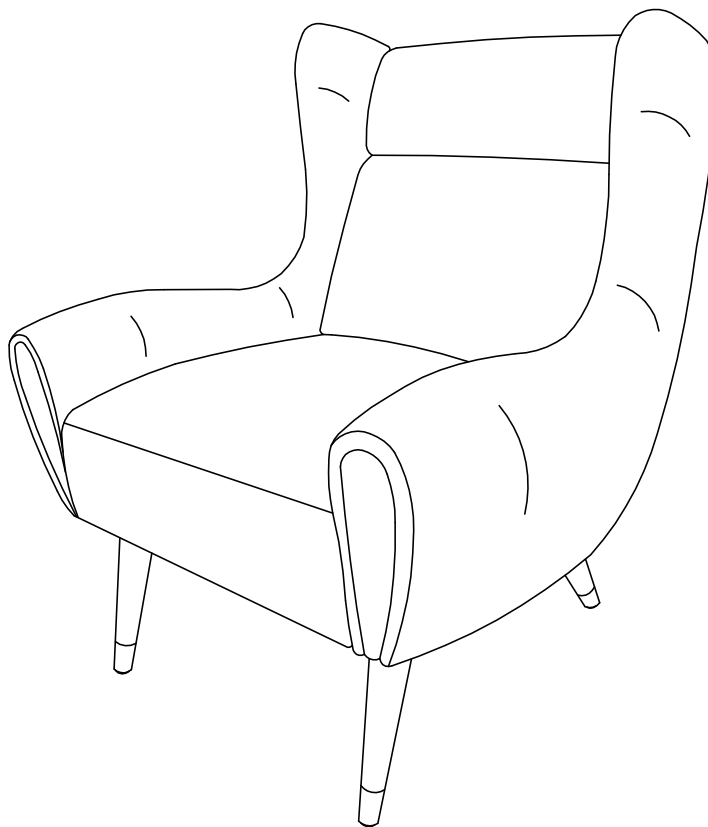

CARE INSTRUCTION FOR FABRIC FURNITURE

In order to maintain the original appearance of your fabric furniture, please follow below simple care procedures.

°Avoid exposing furniture directly to sunlight or heating and air conditioning outlets. Exposure to sunlight or heating and air conditioning outlets will fade/damage fabric.

°Wipe gently with a damp soft cloth to remove dust, dirt and any grime build up.