

# Assembly Instructions



**If necessary, you can contact customer service and ask for an assembly video.**

**Bei Bedarf können Sie den Kundenservice kontaktieren und ein Montagevideo anfordern.**

**Si nécessaire, vous pouvez contacter le service client et demander une vidéo de montage.**

# BEFORE YOU GET STARTED...

*We're confident you'll love your gorgeous new furniture. However, it's worth making absolutely certain before you put it all together.*

*So, let's quickly run through these three steps:*

## 1. COLOUR

Make sure you're happy with the colour

No need to unpack everything, just check the first component.

## 2. PROTECTIVE PACKAGING

If you're happy, then it's time to get opening! Start by laying everything out on the protective packaging – this will prevent anything getting scratched.

## 3. PARTS PAGE

Finally, double check you have all the pieces by referencing the parts page of the instructions.

## TIPS FOR RETURNS

Not completely happy with the product? No problem.

We just need everything back in the original packaging, so follow the steps below and this will ensure a super-smooth returns process and no delay to your refund.

DO



- Check everything is there (the 'parts page' is a handy checklist).
- Pop all the loose fittings and fixtures into the packaging provided or tie them up in a plastic bag.
- Wrap all the big components back up in the original protective packaging.
- Close up the box and seal it securely (don't be afraid to use plenty of tape).

DON'T



- Leave anything assembled - all components should be dismantled and separately packed.
- Put loose fixtures and fittings straight into the box.
- Throw it back in the box carelessly – as it may get damaged.

# BEVOR SIE ANFANGEN...

Wir sind zuversichtlich, dass Sie Ihre wunderschönen neuen Möbel lieben werden. Es lohnt sich jedoch, absolut sicher zu gehen, bevor Sie alles zusammenfügen.

Lassen Sie uns also schnell diese drei Schritte durchgehen:

## 1. FARBE

Stellen Sie sicher, dass Sie mit der Farbe zufrieden sind

Sie müssen nicht alles auspacken, sondern nur die erste Komponente überprüfen.

## 2. SCHUTZVERPACKUNG

Wenn Sie glücklich sind, ist es Zeit, sich zu öffnen! Legen Sie zunächst alles auf die Schutzverpackung, um Kratzer zu vermeiden.

## 3. TEILESEITE

Überprüfen Sie abschließend, ob Sie alle Teile haben, indem Sie auf die Teileseite der

## TIPPS FÜR RÜCKGABEN

Nicht ganz zufrieden mit dem Produkt? Kein Problem. Wir benötigen nur alles wieder in der Originalverpackung. Befolgen Sie daher die nachstehenden Schritte, um einen reibungslosen Rückgabeprozess und keine Verzögerung Ihrer Rückerstattung zu gewährleisten.

### Tun

- Überprüfen Sie, ob alles vorhanden ist (die "Teileseite" ist eine praktische Checkliste).
- Stecken Sie alle losen Teile in die mitgelieferte Verpackung oder binden Sie sie in eine Plastiktüte.
- Wickeln Sie alle großen Komponenten wieder in die Originalverpackung ein.
- Schließen Sie die Box und verschließen Sie sie sicher (Haben Sie keine Angst, viel Klebeband zu verwenden).

### Nicht

- Lassen Sie alles zusammengesetzt.
- Legen Sie verlieren Vorrichtungen direkt in die Box.
- Werfen Sie es achtlos in der Schachtel zurück, da es wird werden kann.

**Dann kontaktieren Sie einfach den Verkäufer um Hilfe.**

# AVANT VOTRE COMMENCEMENT ...

Nous avons la confiance que vous êtes content(e) de votre nouveau meuble.

Mais, ce manuel est important à lire avant votre installation. Ainsi, Laissons-nous passer vite les trois étapes au-dessous :

## 1. Couleur

Assurer que vous êtes d' accord avec la couleur, pas besoin de tout ouvrir, juste vérifier la première accessoire.

## 2. Matière d' emballage protégeant

Si vous êtes content(e), alors il est temps de tout ouvrir! Commencer en mettant tout les parties sur la matière d' emballage protégeant -- qui gardera toutes les accessoires hors des rayures.

## 3. Page d' accessoires

À la fin, vérifier deux fois que vous avez toutes les accessoires à l' aide de la page d' accessoires.

### PETITE ANNONCE POUR LE RETOUR

N' êtes-vous pas content(e) des produits? Pas de souci. Nous avons besoin juste de toutes les parties mises dans l' emballage d' origine. Ainsi que nous vous prions de suivre les étapes au-dessous, qui assure un processus de retour super-doux et le remboursement à temps.

OUI

- Vérifier que toutes les parties sont là (La page d'accessoires est une portée de liste de vérification).
- Mettre toutes les fixations et jeux de vis dans leur sac d'emballage offert ou dans un sac plastique.
- Emballer toutes les grandes parties en les mettant dans leurs matières d'emballage protégeant.
- Fermer le carton et le sceller soyeusement (N'ayez pas peur d'employer beaucoup de chattertons).

NON

- Laisser toutes les parties assemblées - toutes les grandes parties doivent être emballées séparément.
- Mettre les fixations et les jeux de vis directement dans le carton.
- Mettre le produit dans le carton moins de soins - parce qu'il pourrait être endommagé.



If necessary, you can contact customer service and ask for an assembly video.



Bei Bedarf können Sie den Kundenservice kontaktieren und ein Montagevideo anfordern.



Si nécessaire, vous pouvez contacter le service client et demander une vidéo de montage.

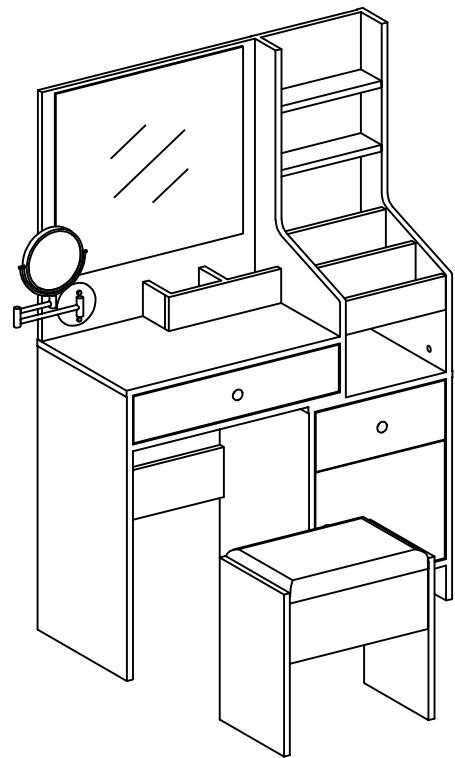

## BEFORE YOU START

### Missing parts

If you are missing any fixtures and fittings for your product, please contact us, and we will be happy to arrange for a replacement to be sent to you free of charge.

### A fault product

If you have a fault with your product please contact the seller, we will help you to make it right.

## BEVOR DU ANFÄNGST

### Fehlende Teile

Wenn Sie irgendwelche Einrichtungsgegenstände für Ihr Produkt vermissen, kontaktieren Sie uns bitte, und wir arrangieren gerne einen kostenlosen Ersatz, der Ihnen zugesandt wird.

### Ein Fehlerprodukt

Wenn Sie einen Fehler an Ihrem Produkt haben, wenden Sie sich bitte an den Verkäufer. Wir helfen Ihnen dabei, das Problem zu beheben.

## Avant votre démarrage

### Des accessoires perdues :









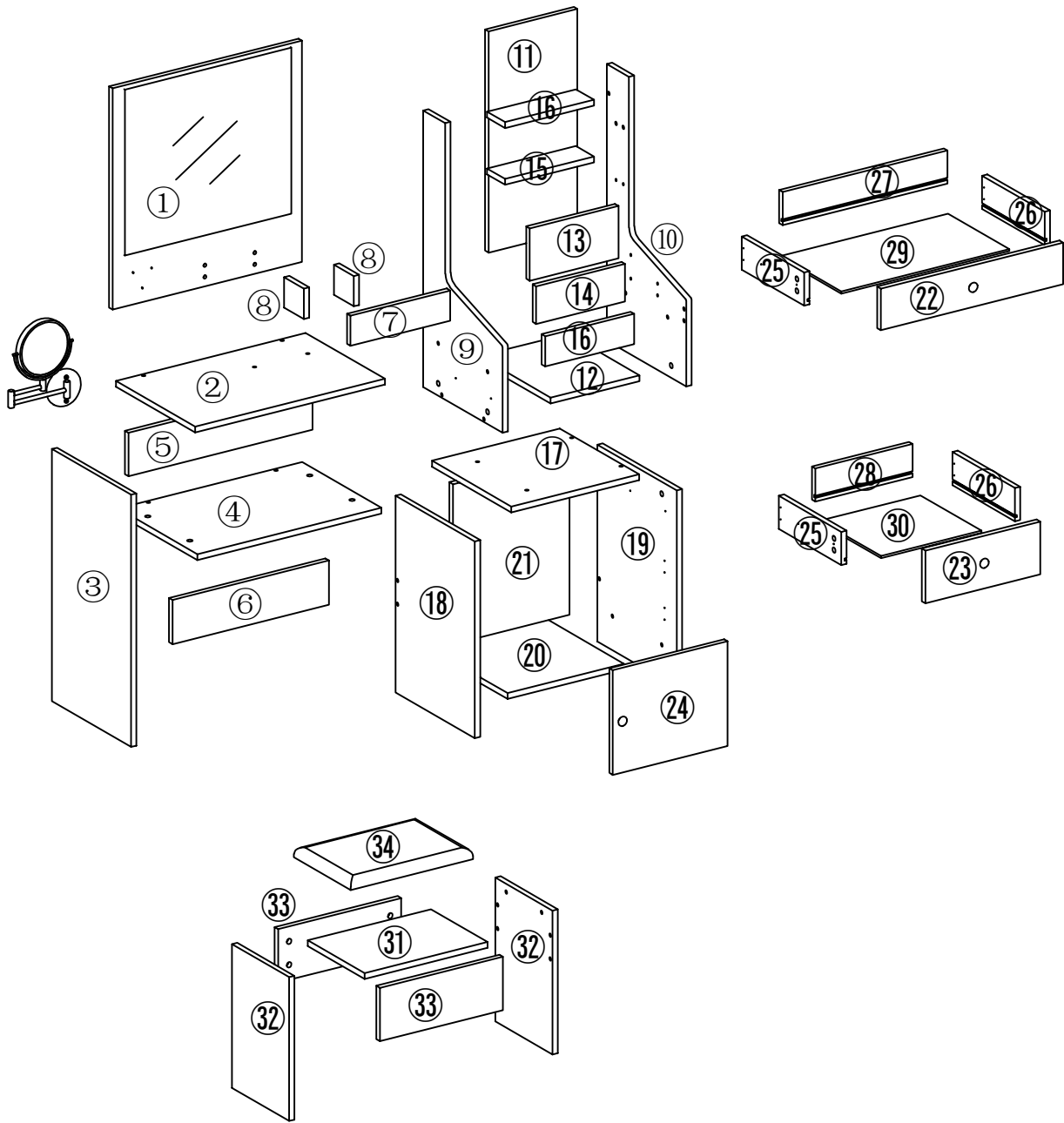





Si vous avez perdu toute fixation, contactez-nous SVP, et nous sommes très heureux de vous envoyer ces parties gratuitement.

### Un produit faux :

Si vous avez un produit faux, nous vous prions de contacter nos vendeurs, on vous aidera à le corriger.

# GETTING TO KNOW YOUR PRODUCT

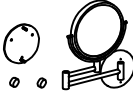

<b>A1</b>  84 PCS	<b>A2</b>  84 PCS	<b>B</b> 8*40  12 PCS	<b>C</b> 3.5*14  45 PCS	<b>D</b> 3.5*35  8 PCS	<b>E</b>  3 PCS	<b>F</b> 4*20  3 PCS
<b>G</b> 43*15*7  1 PCS	<b>H</b> 47*32*1  1 PCS	<b>I</b>  2 PCS	<b>J</b> 300mm J1  J2  4 PCS	<b>K</b>  1 PCS	 1 PCS	

BOX 1/2	
PARTNO.	QTY
②	1
③	1
④	1
⑥	1
⑦	1
⑨	1
⑩	1
⑰	1
⑱	1
⑲	1
⑳	1
㉑	1
㉔	1
㉕	2
㉖	2
㉓	2
㉔	2

BOX 2/2	
PARTNO.	QTY
①	1
⑤	1
⑧	2
⑪	1
⑫	1
⑬	1
⑭	1
⑮	1
⑯	2
㉒	1
㉓	1
㉗	1
㉘	1
㉙	1
㉚	1
㉛	1
㉜	1



### Hardware installation demonstration

- Please make sure "A" hardware tightened and can't be pulled out

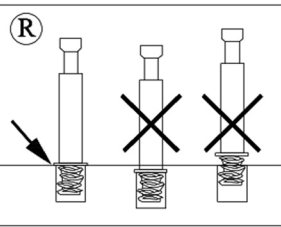
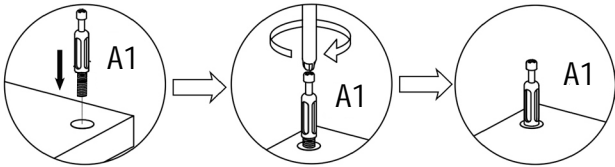

### Hardware installation demonstration

- When inserting cam ensure arrowhead on cam points toward to the hole on the panel edge

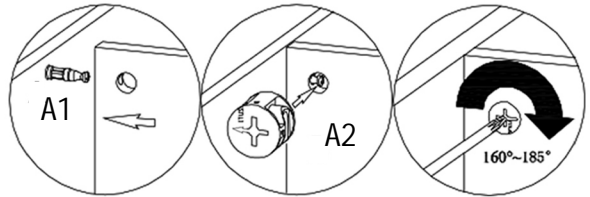

### Hardware installation demonstration

- Before installing the drawer rail, you need to separate the K1 and K2 first.

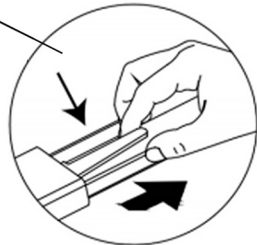
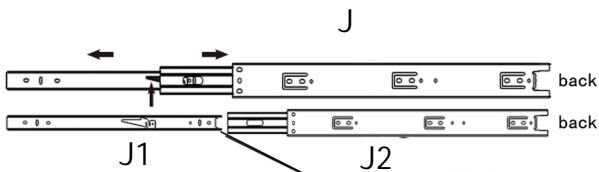

Warm Reminder: Press it and split



### Hardware installation demonstration

- The first screw hole should corresponded with the board location hole

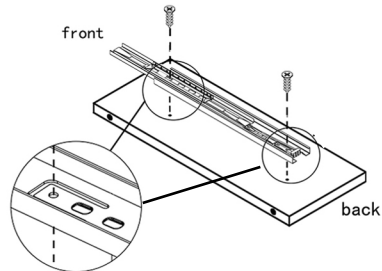

- The first screw hole should corresponded with the board location hole

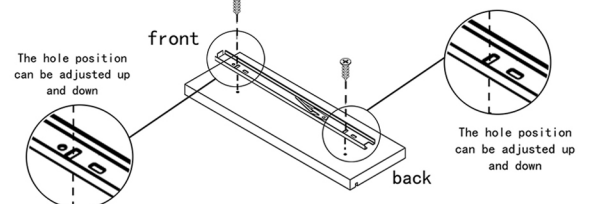

1

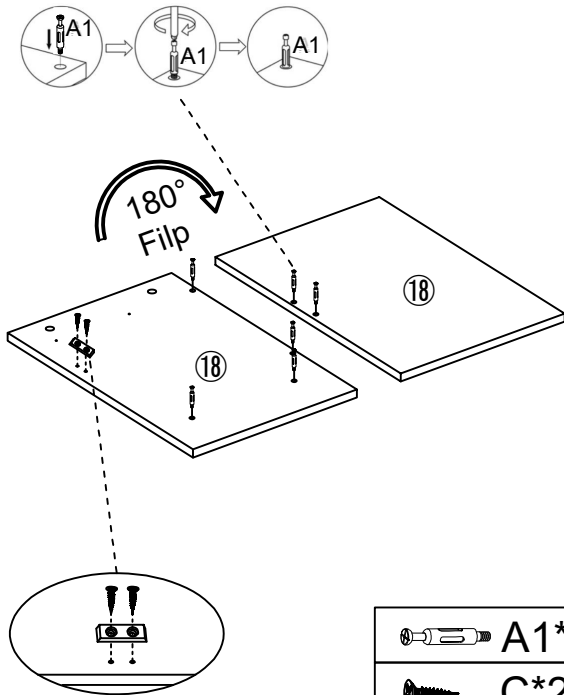

- A1\*6
- C\*2
- G\*1

2

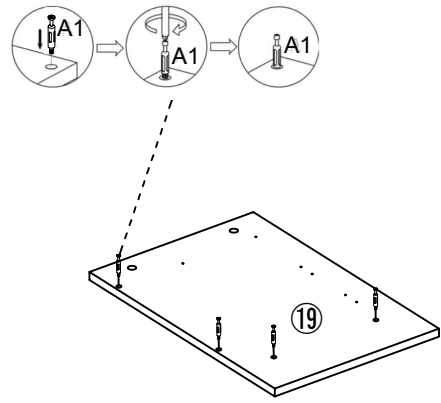

- A1\*4

3

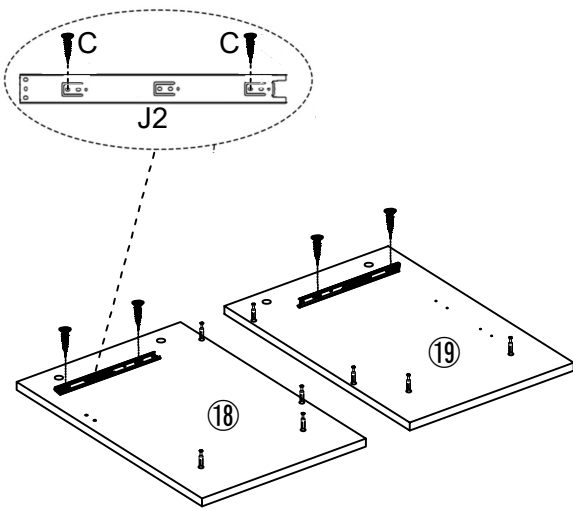

- C\*4
- J2\*2

4

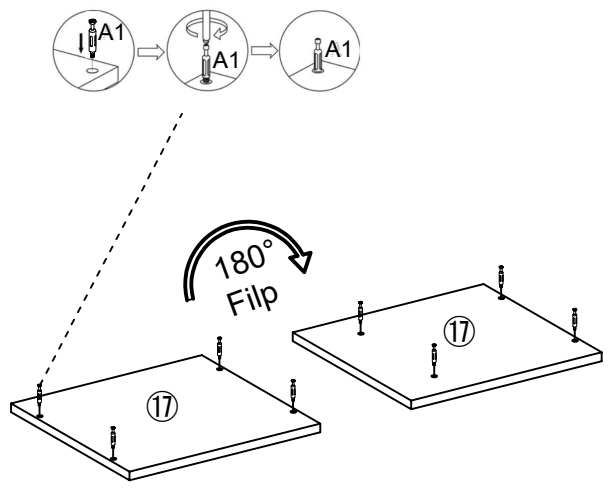

- A1\*8

1

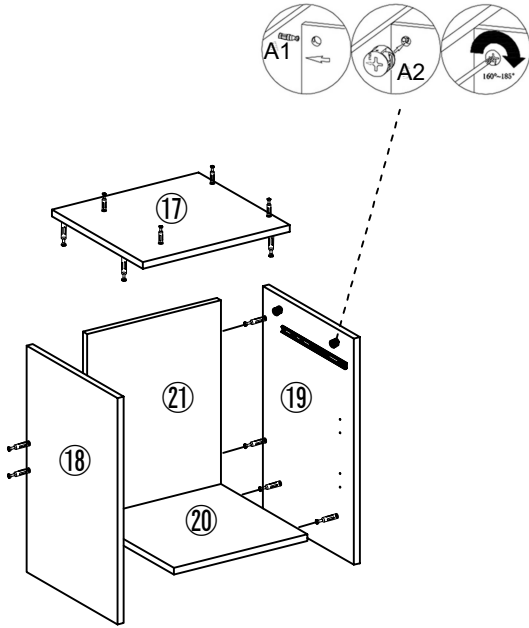

A2\*12

2

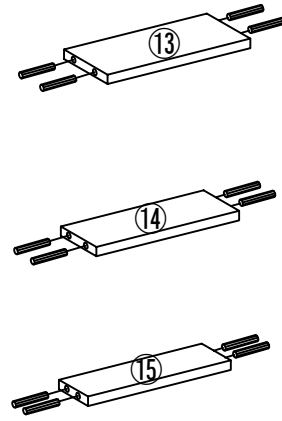

B\*12

3

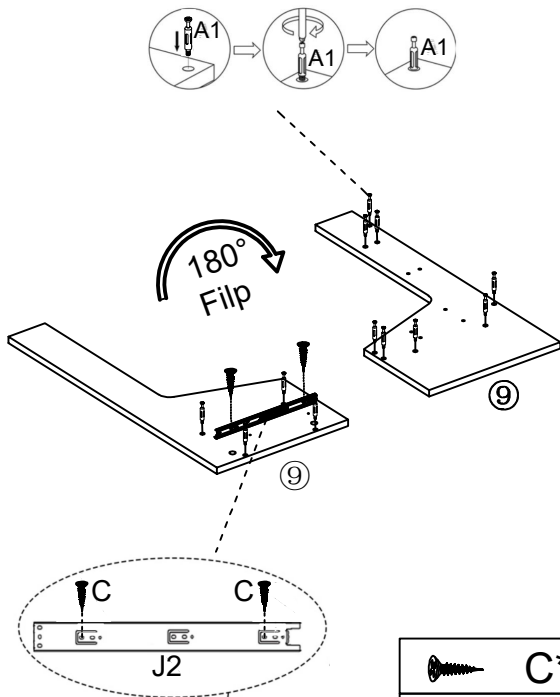

C\*2

J2\*1

A1\*12

4

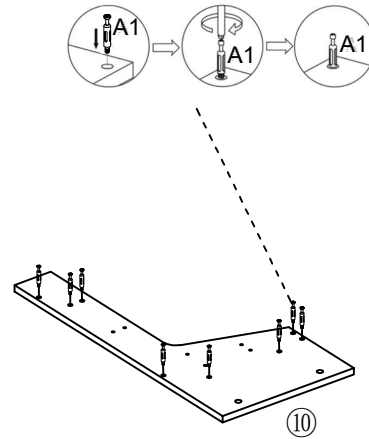

A1\*8

1

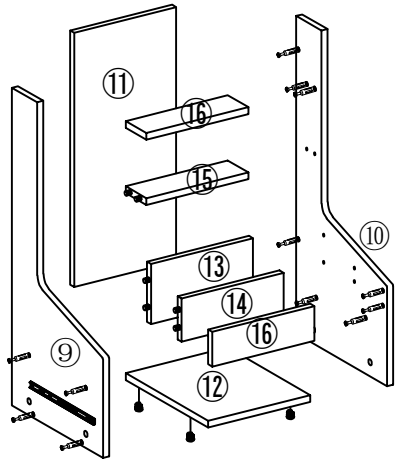
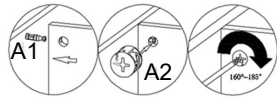

 A2\*16

2

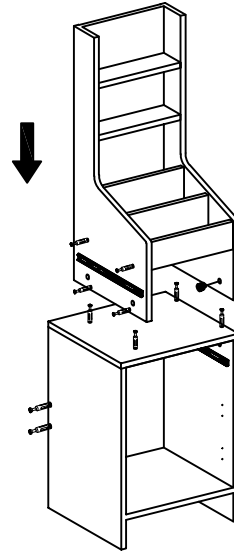
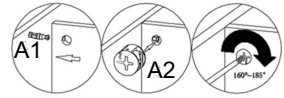

 A2\*4

3

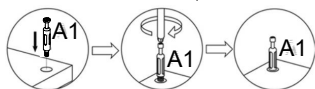
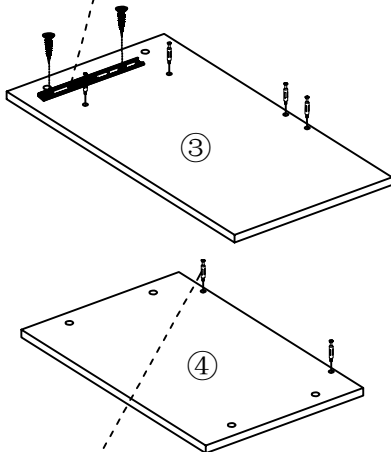
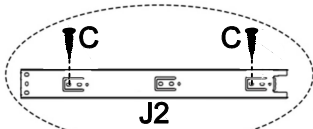

 A1\*6

 C\*2

 J2\*1

4

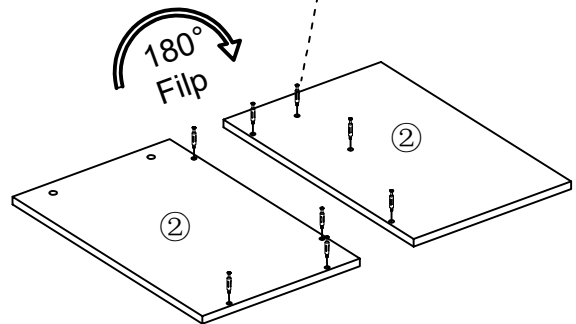
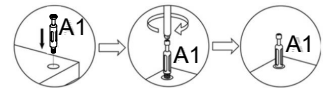

 A1\*8

5

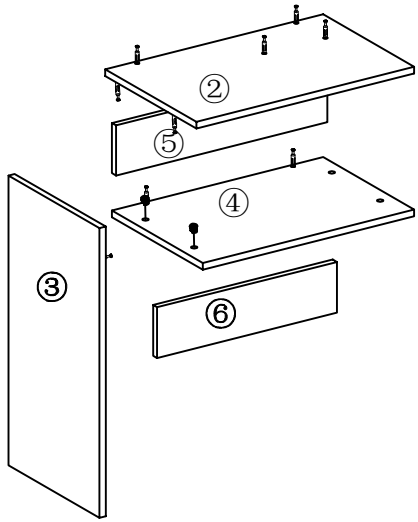
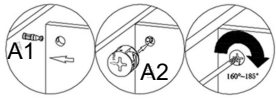

A2\*10

6

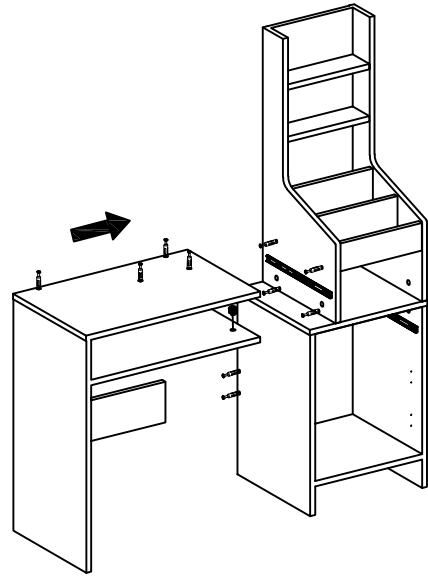

A2\*6

7

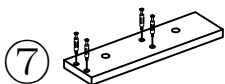
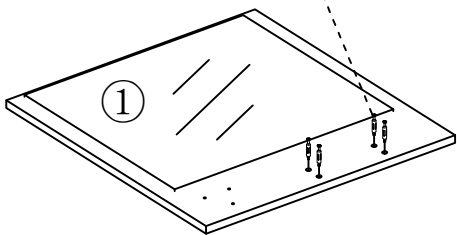
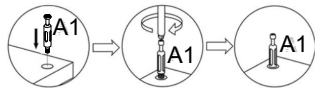

A1\*8

8

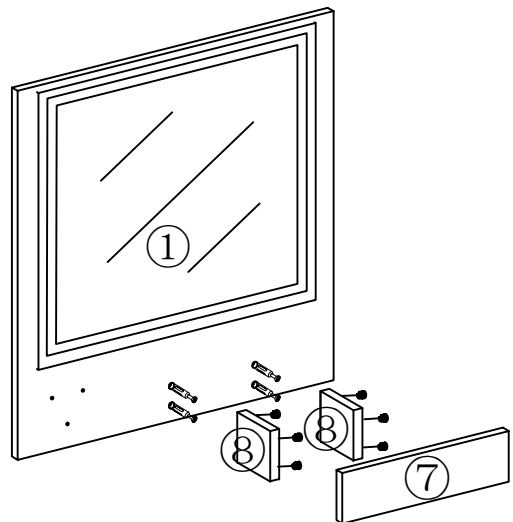
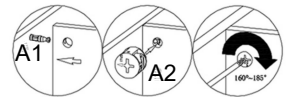

A2\*8

9

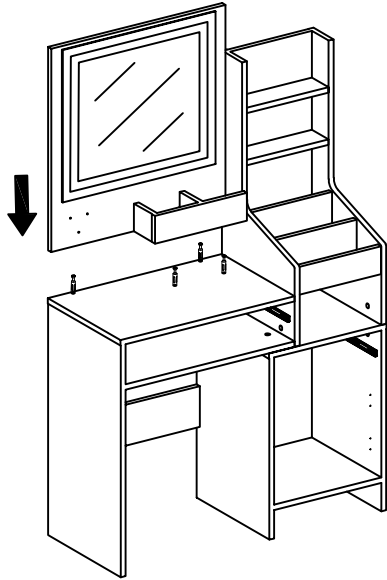

A2\*4

10

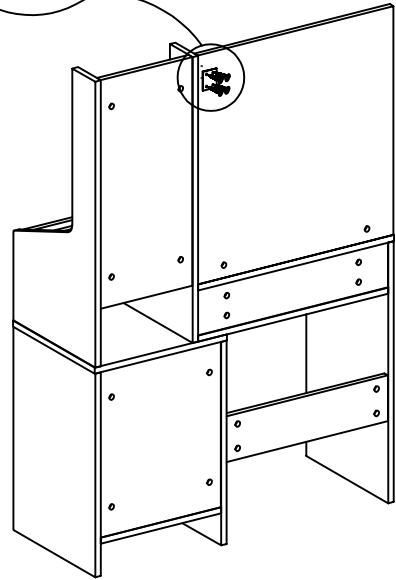
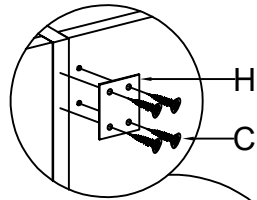

C\*4  
 H\*1

11

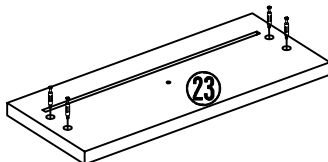
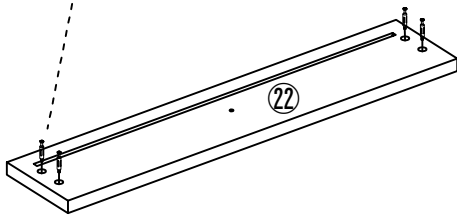
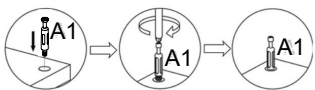

A1\*8

12

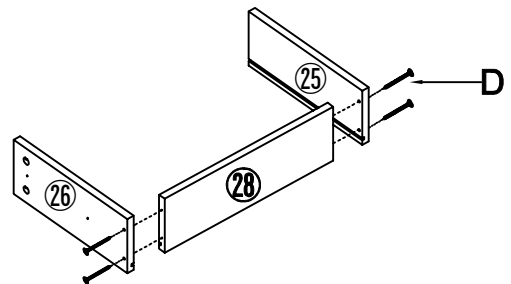
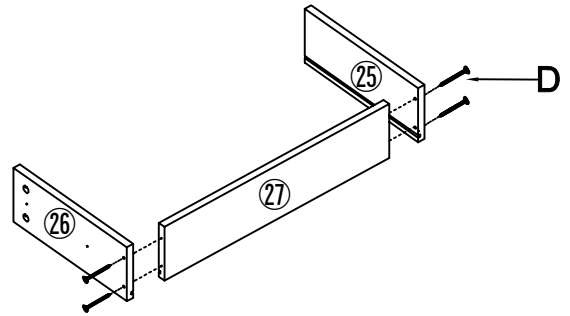

D\*8

9

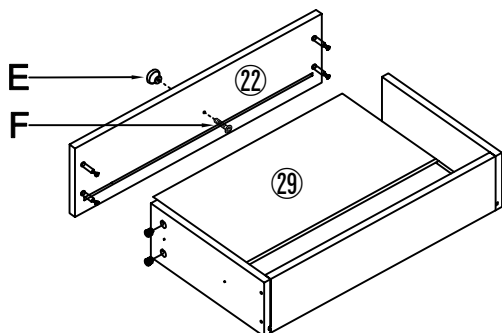
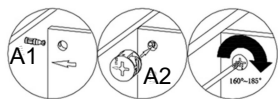

	A2*4
	E*1
	F*1

10

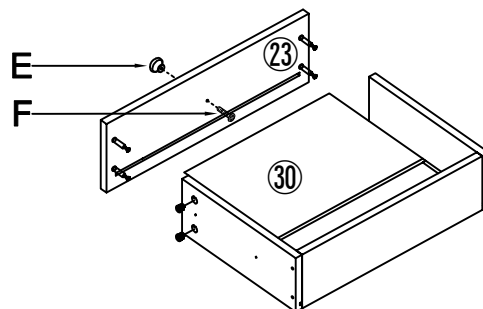
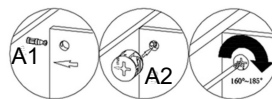

	A2*4
	E*1
	F*1

11

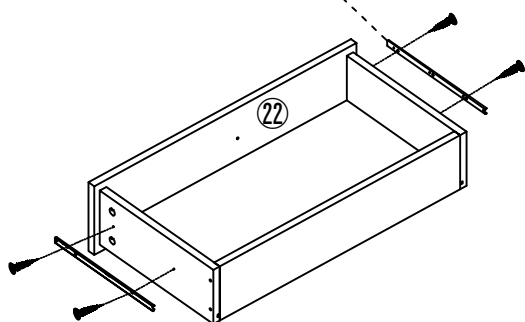
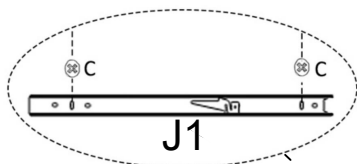

	C*4
	J1*2

12

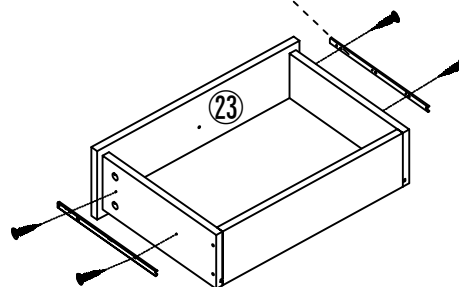
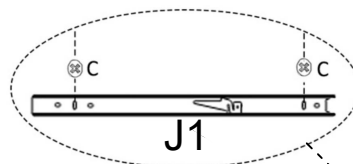



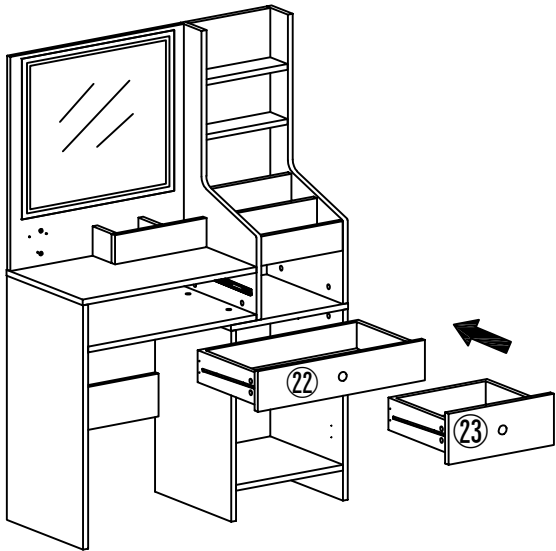

	C*4
	J1*2

13

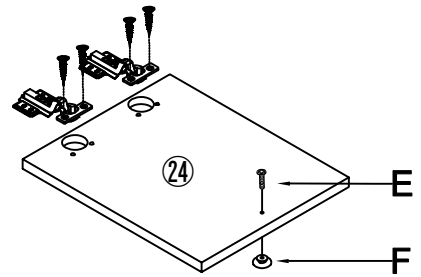



14



	C*4
	I*2
	E*1
	F*1

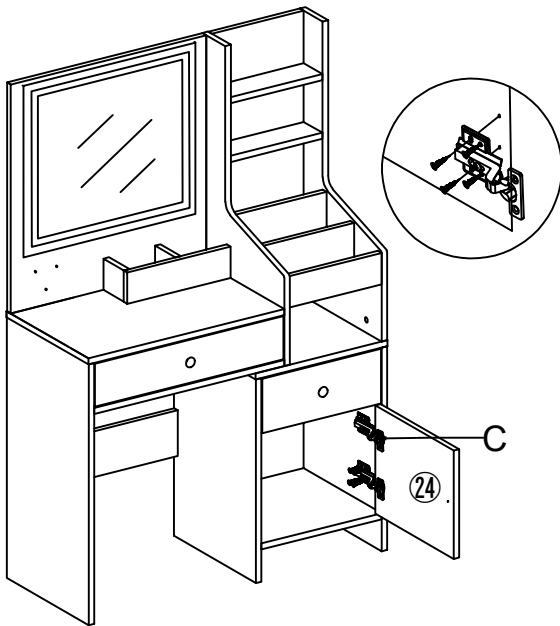

15

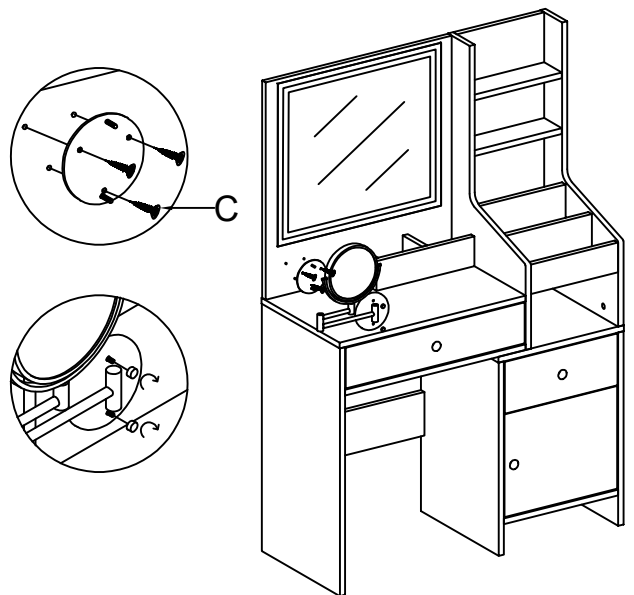

	C*8
---	-----

16



	C*3
	K*1

17

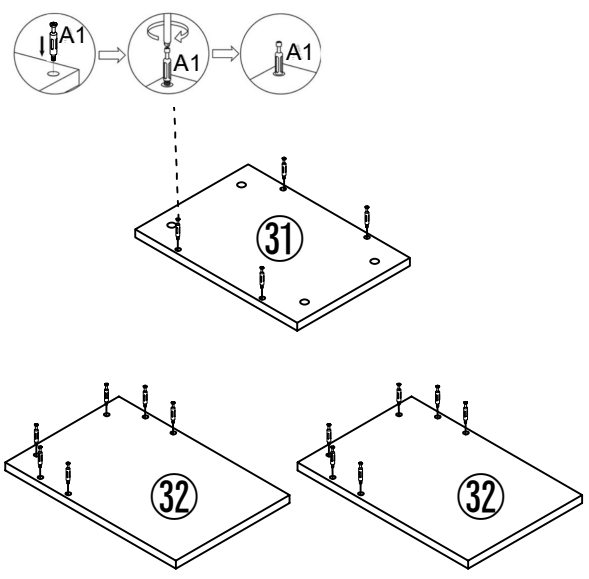

 A1\*16

18

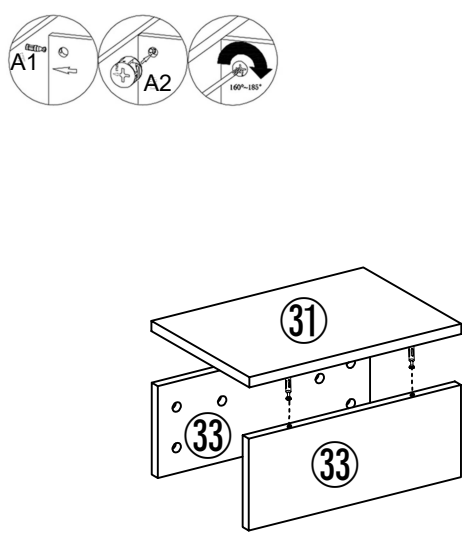

 A2\*4

19

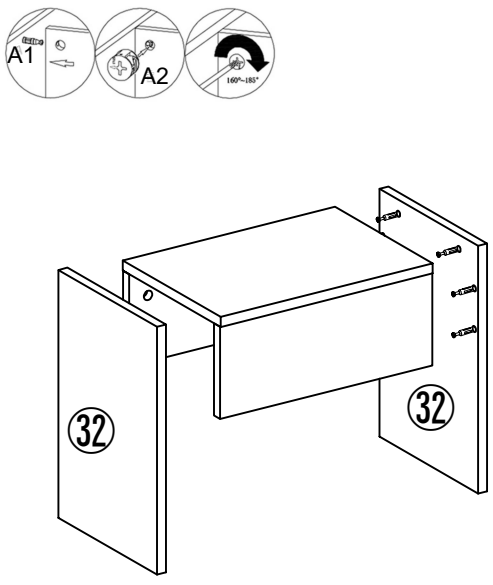

 A2\*12

20

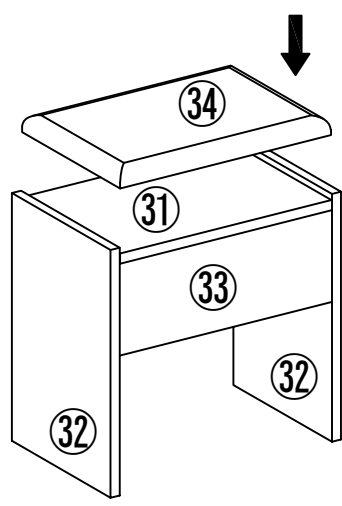

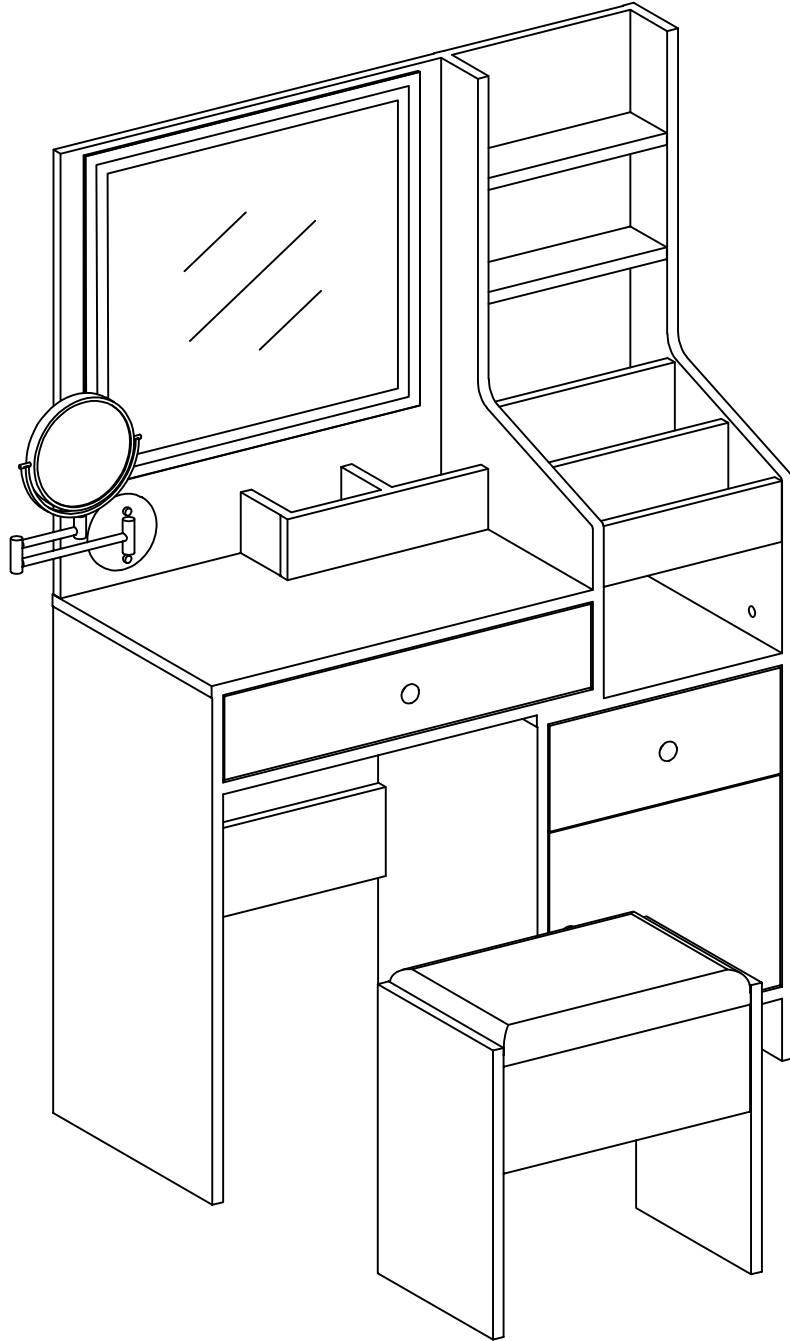

## Warnings

We suggest you retain these instructions for future reference.

Keep fittings out of children's reach and keep children well away from the construction area.

This product should only be used on firm, level ground.

Please periodically check all fittings and re-tighten as necessary.

Avoid exposing the furniture to excessive heat or direct sunlight as this can cause deterioration of the colour.

Unwrap all packaging materials and place the components on top of the carton box or on a clean floor to protect it from damage.

## Do's

We suggest you spend a short time reading through this leaflet before you start.

When you are ready to start, make sure that you have the right tools and plenty of space.

Unwrap all packaging materials and place the components on a clean surface to protect it from damage.

We recommend that the packaging is used to protect the surfaces during assembly.

Carefully check that you have all the parts before beginning assembly

Ensure the product is fully assembled as illustrated and all fixings are fully tightened before use.

## Don'ts

Do not drag or pull your furniture.

Do not use silicone based furniture polish. Silicone in furniture polishes can break down the finish.

Never allow any kind of liquid to remain on your furniture.

Do not stand or lean back on your chairs.

**When using electric tools, please pay attention to the depth of the screw. Excessive force will damage the plate.**

## **Warnungen**

Wir empfehlen Ihnen, diese Anweisungen zum späteren Nachschlagen aufzubewahren.  
Halten Sie Armaturen außerhalb der Reichweite von Kindern und halten Sie Kinder von der Baustelle fern.

Dieses Produkt sollte nur auf festem, ebenem Boden verwendet werden.

Bitte überprüfen Sie regelmäßig alle Armaturen und ziehen Sie sie bei Bedarf wieder fest.

Setzen Sie die Möbel keiner übermäßigen Hitze oder direkter Sonneneinstrahlung aus, da dies zu einer Verschlechterung der Farbe führen kann.

Packen Sie alle Verpackungsmaterialien aus und legen Sie die Komponenten auf den Karton oder auf einen sauberen Boden, um ihn vor Beschädigungen zu schützen.

## **Tun**

Wir empfehlen Ihnen, diese Broschüre kurz durchzulesen, bevor Sie beginnen.

Wenn Sie bereit sind, stellen Sie sicher, dass Sie die richtigen Werkzeuge und viel Platz haben.

Wickeln Sie alle Verpackungsmaterialien aus und legen Sie die Komponenten auf eine saubere Oberfläche, um sie vor Beschädigungen zu schützen.

Wir empfehlen, die Verpackung zum Schutz der Oberflächen bei der Montage zu verwenden.

Überprüfen Sie sorgfältig, ob Sie alle Teile haben, bevor Sie mit der Montage beginnen. Stellen Sie sicher, dass das Produkt wie abgebildet vollständig montiert und alle Befestigungen vor dem Gebrauch fest angezogen sind.

## **Nicht**

Ziehen oder ziehen Sie nicht an Ihren Möbeln.

Verwenden Sie keine Möbelpolitur auf Silikonbasis. Silikon in Möbelpolituren kann das Finish beschädigen.

Lassen Sie niemals Flüssigkeiten auf Ihren Möbeln zurück.

Stellen Sie sich nicht auf Ihre Stühle und lehnen Sie sich nicht zurück.

## **Avertissement**

Nous vous conseillons de garder ces instructions pour la référence future.

Gardez les enfants hors des fixations et de la zone d'installation.

Le produit doit être utilisé sur le sol à la fois solide et horizontal.

Nous vous prions de bien vérifier les fixations périodiquement.

Eviter d'exposer le produit sous un température trop élevé ou sous la lumière de soleil directe, qui causerais la détérioration de la couleur.

Détacher toutes les matières d'emballage et mettre les parties sur le carton ou sur un sol propre afin de les garder hors des rayures.

## **Oui**

Nous vous conseillons de lire ces feuilles en peu de temps avant votre commencement.

Quand you décidez de commencer l'installation, assurez que vous avez l'outil correct et assez de place.

Détacher toutes les matières d'emballage et mettre les parties sur un sol propre afin de les garder hors des rayures.

Nous vous recommandons que les matières d'emballage sont pour protéger les surfaces pendant l'installation.

Vérifier bien que vous avez toutes les parties avant le commencement.

Assurer que le produit est pleinement assemblé comme des illustrations et toutes les fixations soient bien faites avant l'emploi.

## **Non**

Ne remorquer ni tirer votre produit.

N'utilisez pas de polisseur de meubles à base de silicium, qui peut endommager la peinture.