

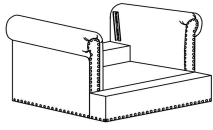

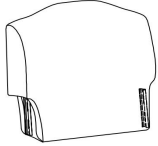
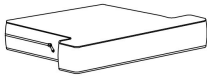

ASSEMBLY INSTRUCTION

PARTS

S.NO.	DESCRIPTION	QTY
A	 Seat Frame	1
B	 Metal base	1
C	 Seat cushion	1
D	 Front legs	2
E	 Back legs	2

HARDWARE

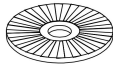
S.NO.	DESCRIPTION	QTY
①	 Bolt M8x18mm	4
②	 Allen Key 6mm	1
③	 Flat washer	2

STEP1

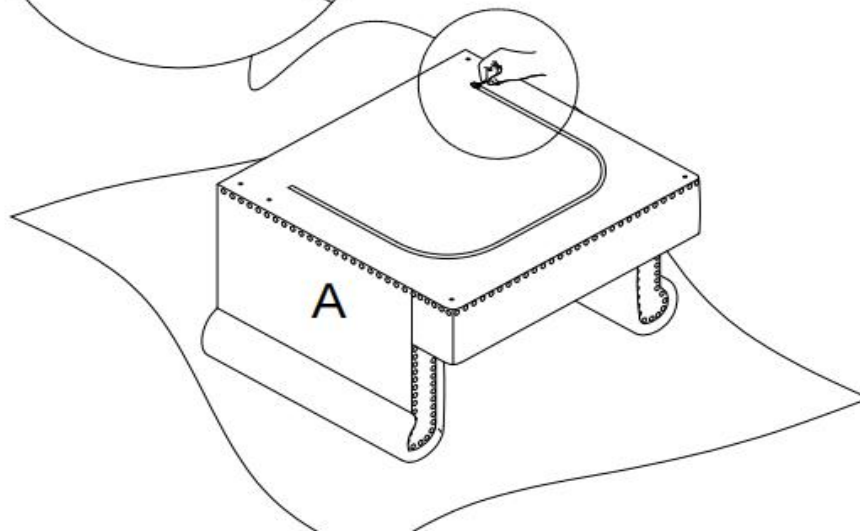
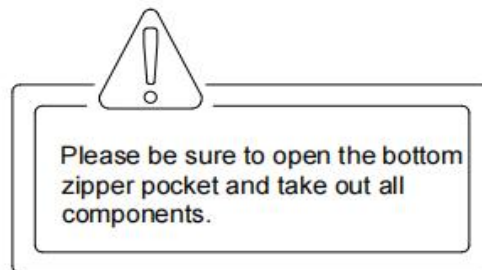
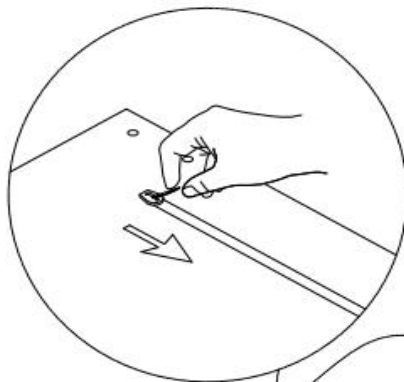

STEP 2

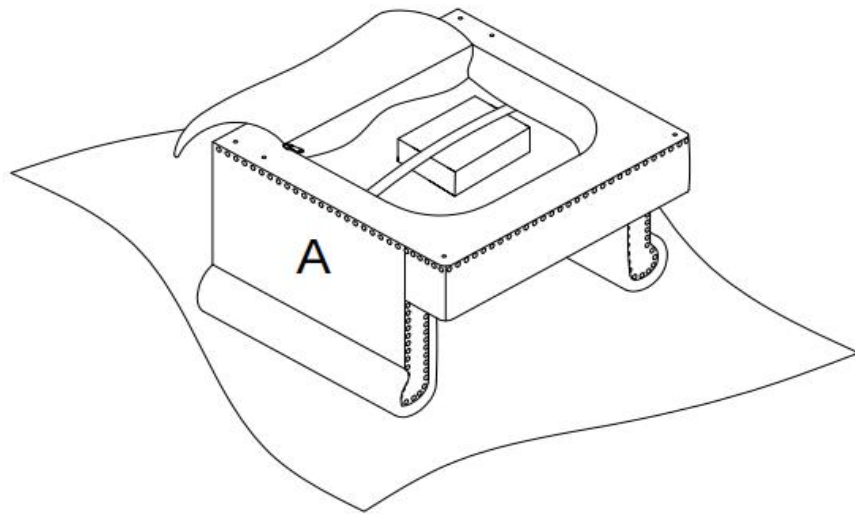

STEP 3

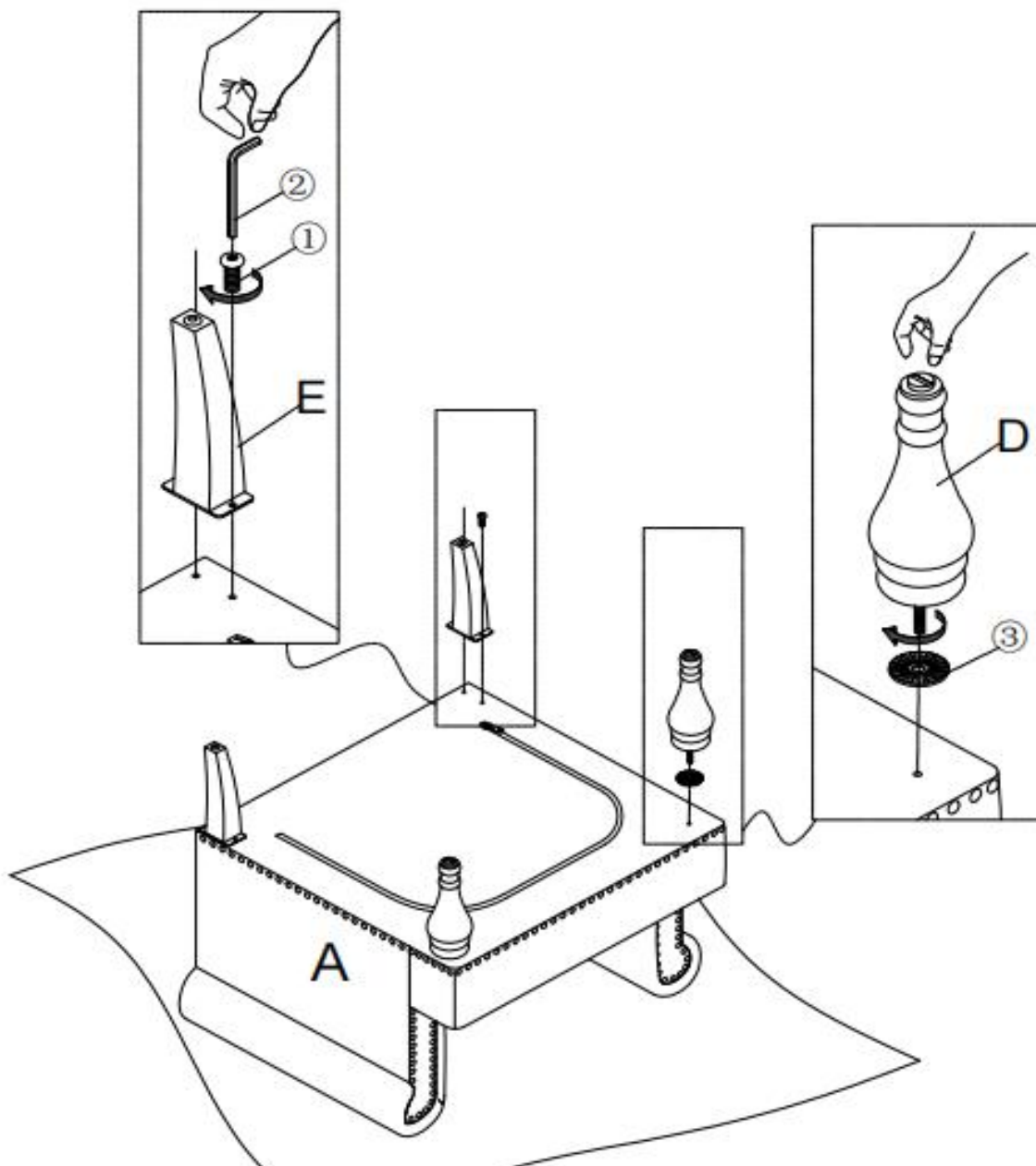

STEP 4

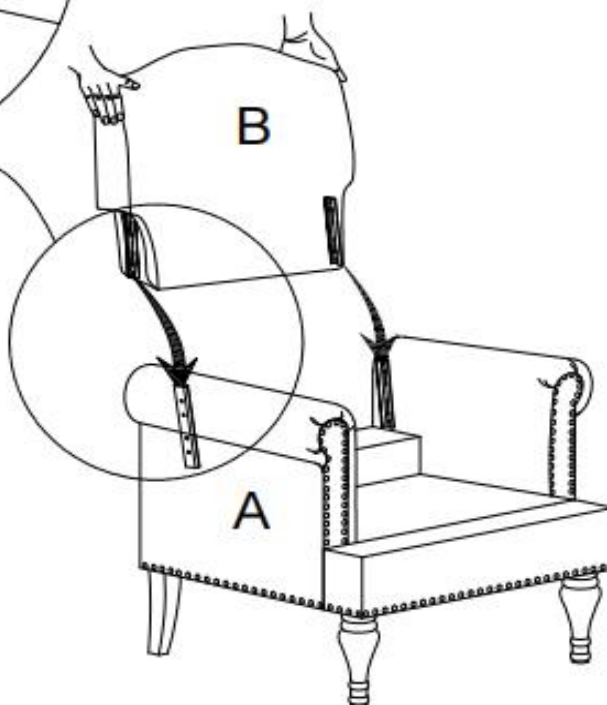
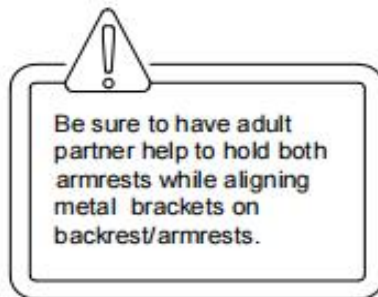
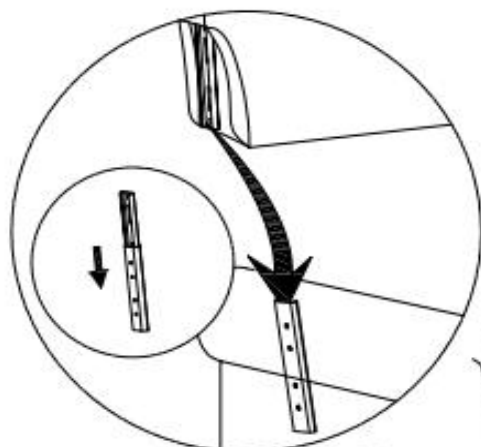

STEP 5

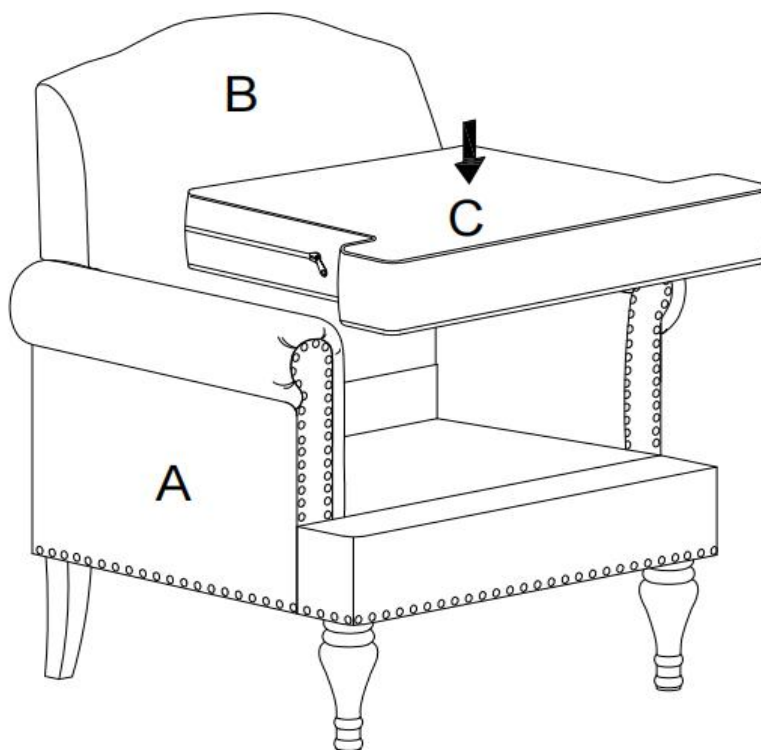
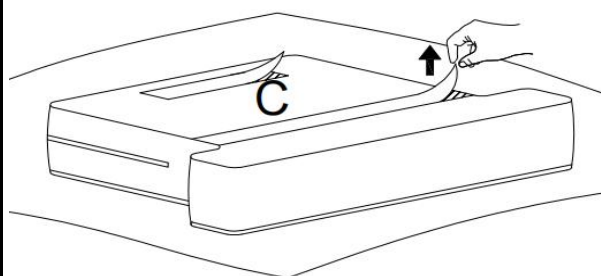

STEP 6

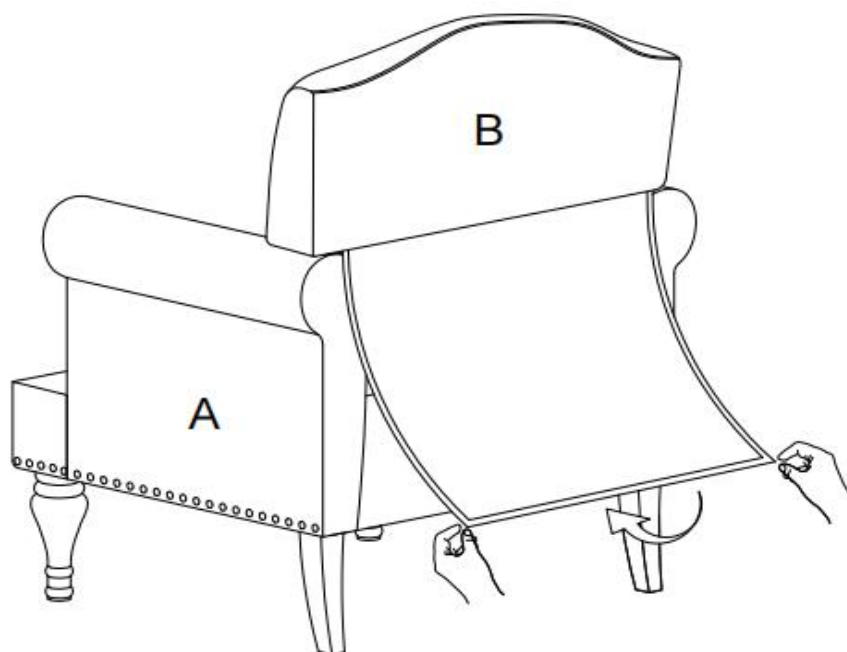

FINISH



Attention:
After installation, adjust the adjustable leveler to keep the chair balanced.
Be sure to check all packing material carefully for small parts, which may have come loose inside the carton during shipment.

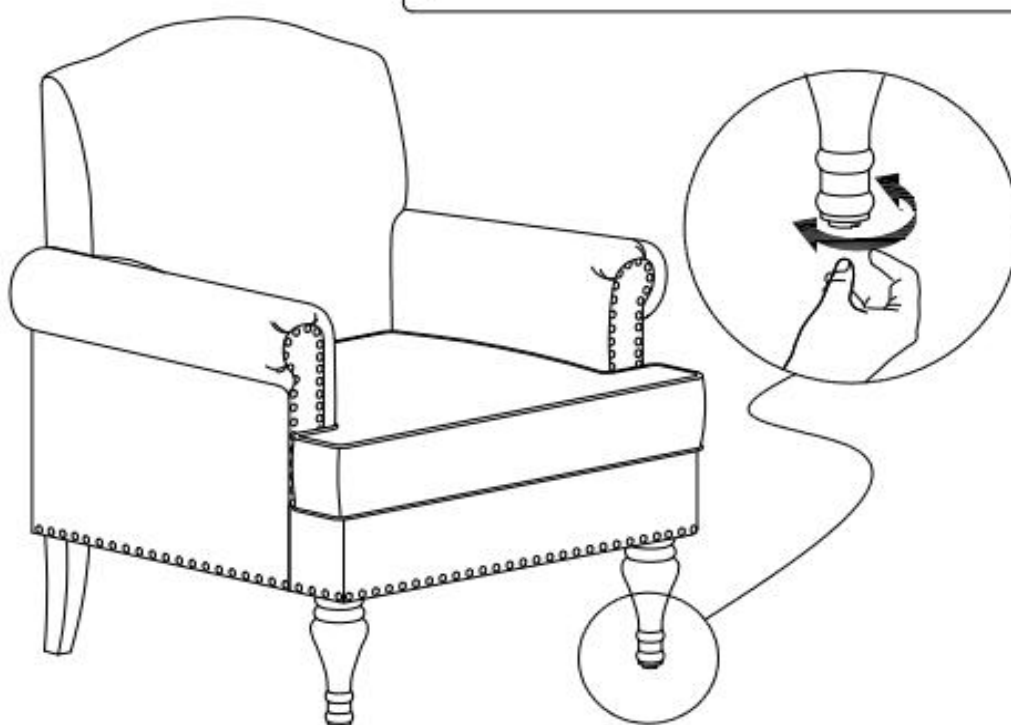

MADE IN CHINA