

ASSEMBLY INSTRUCTION

INSTRUCTIONS DE MONTAGE

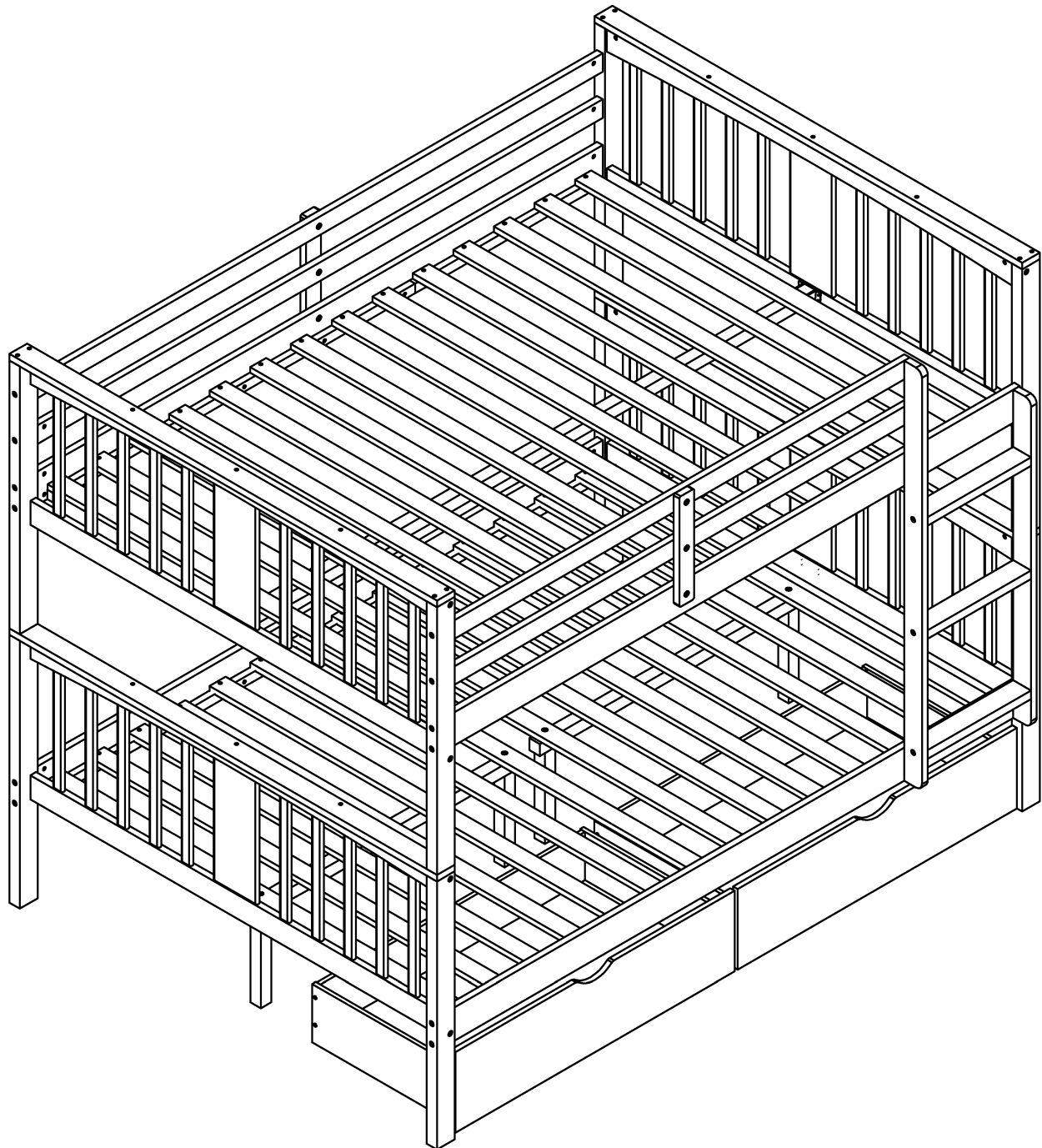



SAFETY WARNINGS



1. This bed is designed for use only mattress(es) meeting the following specifications on the upper bunk and lower bunk:

Upper bed

<i>Bed Type</i>	<i>Length</i>	<i>Width</i>	<i>Thickness</i>
<i>Full Standard</i>	<i>74"-75"</i>	<i>54"</i>	<i>6" max</i>

lower bed

<i>Bed Type</i>	<i>Length</i>	<i>Width</i>	<i>Thickness</i>
<i>Full Standard</i>	<i>74"-75"</i>	<i>54"</i>	<i>6" max</i>

2. Replacement parts, including additional guardrails, maybe obtained from any of our dealers.
3. Follow the information on the warnings appearing on the upper bunk bed end structure and on the carton. Do not remove warning label from bed.
4. Always use the recommended size mattresses or mattress supports, or both, to help prevent the likelihood of entrapment or falls.
5. Surface of the mattress must be at least 5". (127 mm) below the upper edge of guardrails.
6. Do not allow children under 6 years of age to use the upper bunk.
7. Periodically check and ensure that the guardrail, ladder, and other components are in their proper position, free from damage, and that all connectors are tight.
8. Do not allow horseplay on or under the bed and prohibit jumping on the bed
9. Always use the ladder for entering and leaving the upper bunk.
10. Do not use substitute parts. Contact the manufacturer or dealer for replacement parts.
11. Use of a night light may provided added safety precaution for a child using the upper bunk.
12. Always use guardrails on both long sides of the upper bunk. If the bunk bed will be placed next to the wall, the guardrail that runs the full length of the bed should be placed against the wall to prevent entrapment between the bed and wall.
13. The use of water or sleep flotation mattresses is prohibited.
14. STRANGULATION HAZARD - Never attach or hang items to any part of the bunk bed that are not designed for use with the bed; for example, but not limited to, hook, belts and jump ropes.
15. Keep these instructions for future reference
16. Prohibit more than one person on upper bunk.
17. We recommend assembling your bunk bed on the shipping carton to protect your floor or carpet.
18. Be certain all staples are out of the box before beginning assembly on the shipping carton.



AVERTISSEMENTS DE SÉCURITÉ



1. Ce lit est conçu pour être utilisé uniquement avec des matelas répondant aux spécifications suivantes pour la couchette supérieure et la couchette inférieure :

Lit supérieur

Type de lit	Longueur	Largeur	Épaisseur
Norme complète	74"-75"	54"	6" max

Lit inférieur

Type de lit	Longueur	Largeur	Épaisseur
Norme complète	74"-75"	54"	6" max

2. Des pièces de rechange, y compris des garde-corps supplémentaires, peuvent être obtenues auprès de l'un de nos revendeurs.
3. Suivez les informations sur les avertissements apparaissant sur la structure d'extrémité supérieure du lit superposé et sur le carton. Ne retirez pas l'étiquette d'avertissement du lit.
4. Utilisez toujours des matelas ou des supports de matelas de taille recommandée, ou les deux, pour éviter tout risque de coincement ou de chute.
5. La surface du matelas doit être à au moins 5". (127 mm) sous le bord supérieur des garde-corps.
6. Ne laissez pas les enfants de moins de 6 ans utiliser le lit supérieur.
7. Vérifiez et assurez-vous périodiquement que le garde-corps, l'échelle et les autres composants sont dans la bonne position. exempt de dommages et que tous les connecteurs sont bien serrés.
8. Ne laissez pas les chahuts sur ou sous le lit et interdisez de sauter sur le lit
9. Utilisez toujours l'échelle pour entrer et sortir du lit supérieur.
10. N'utilisez pas de pièces de rechange. Contactez le fabricant ou le revendeur pour les pièces de rechange.
11. L'utilisation d'une veilleuse peut constituer une mesure de sécurité supplémentaire pour un enfant utilisant le lit supérieur.
12. Utilisez toujours des garde-corps sur les deux côtés longs du lit supérieur. Si le lit superposé est placé à côté du mur, le garde-corps qui s'étend sur toute la longueur du lit doit être placé contre le mur pour éviter tout coincement entre le lit et le mur.
13. L'utilisation de matelas flottants à eau ou de sommeil est interdite.
14. **RISQUE D'ÉTRANGULATION** - N'attachez ou ne suspendez jamais d'objets à une partie du lit superposé qui sont non conçu pour être utilisé avec le lit ; par exemple, mais sans s'y limiter, les crochets, les ceintures et les cordes à sauter.
15. Conservez ces instructions pour référence future
16. Interdire plus d'une personne sur la couchette supérieure.
17. Nous vous recommandons d'assembler votre lit superposé sur le carton d'expédition pour protéger votre sol ou votre tapis.
18. Assurez-vous que toutes les agrafes sont sorties de la boîte avant de commencer l'assemblage sur le carton d'expédition.



SAFETY WARNINGS



1. At the beginning :

Tighten all hardware.

Check metal parts for rust. If found, sand and repaint using a non-lead-based paint meeting the requirements of 16 CFR 1303.

Check all wood members for deterioration and splinters. Sand down splinters and replace deteriorating wood members.

Rake and check depth of loose fill protective surfacing materials to prevent compaction and to maintain appropriate depth.

Replace as necessary.

2. Twice a month

Tighten all hardware.

Rake and check depth of loose fill protective surfacing materials to prevent compaction and to maintain appropriate depth.

Replace as necessary.

3. Owners shall be responsible for maintaining the legibility of the warning labels.

4. Disposal Instructions-

There shall be instructions advising the owner to disassemble and dispose of the playground equipment in such a way that no unreasonable hazards will exist at the time the playground equipment is discarded.

5. The instructions shall also include the information found in Section 4 of the United States Consumer Product Safety Commission's (USCPSC) Outdoor Home Playground Safety Handbook or specific surfacing guidelines for the product consistent with the USCPSC Handbook. A copy of this section may be found in Appendix X2.

6. Observing the following statements and warnings reduces the likelihood of serious or fatal injury.

7. Specifying the number and weight of occupants that may safely use the equipment singly or simultaneously,

8. Recommending on-site adult supervision for children of all ages,

9. Warning the owner to instruct children not to use the equipment in a manner other than intended,

10. Warning the owner to instruct children not to get off equipment while it is in motion,

11. Warning the owner not to allow children to wear inappropriate items, such as but not limited to, loose fitting clothing, hood and neck drawstrings, scarves, cord-connected items, capes and ponchos. These items can cause death by strangulation.

12. Warning the owner to instruct children not to climb when the equipment is wet.

13. Warning the owner to instruct children not to attach items to the playground equipment that are not specifically designed for use with the equipment, such as, but not limited to, jump ropes, clothesline, pet leashes, cables and chain as they may cause a strangulation hazard

14. Warning the owner to instruct children to remove their bike or other sports helmet before playing on the playground equipment.

15. Warning the owner to dress children with well-fitting and full foot enclosing footwear. Examples of inappropriate footwear are clogs, flip flops, and sandals.

16. Place the equipment on level ground, not less than 6 ft (1.8 m) from any structure or obstruction such as a fence, garage, house, overhanging branches, laundry lines, or electrical wires

17. Do not install home playground equipment over concrete, asphalt, packed earth, grass, carpet, or any other hard surface. A fall onto a hard surface can result in serious injury or death to the equipment user

18. To prevent serious injury, cautionary statements shall be included which warn that children must not use the equipment until properly installed.



AVERTISSEMENTS DE SÉCURITÉ



1. Au début :

Serrez tous les éléments de quincaillerie.

Vérifiez les pièces métalliques pour détecter la rouille. Si de la rouille est présente, poncez et repeignez avec une peinture sans plomb répondant aux exigences de la norme 16 CFR 1303.

Vérifiez toutes les pièces en bois pour détecter les détériorations et les éclats. Poncez les éclats et remplacez les pièces en bois détériorées.

Ratissez et vérifiez la profondeur des matériaux de revêtement de protection en vrac pour éviter le compactage et maintenir une profondeur appropriée. Remplacez si nécessaire.

2. Deux fois par mois :

Serrez tous les éléments de quincaillerie.

Ratissez et vérifiez la profondeur des matériaux de revêtement de protection en vrac pour éviter le compactage et maintenir une profondeur appropriée. Remplacez si nécessaire.

3. Les propriétaires sont responsables du maintien de la lisibilité des étiquettes de mise en garde.

4. Instructions de mise au rebut :

Il doit y avoir des instructions conseillant au propriétaire de démonter et de mettre au rebut les équipements de jeux de manière à ce qu'aucun danger déraisonnable n'existe au moment de l'élimination de l'équipement de jeux.

5. Les instructions doivent également inclure les informations trouvées dans la section 4 du "United States Consumer Product Safety Commission's (USCPSC) Outdoor Home Playground Safety Handbook" ou des recommandations spécifiques sur le revêtement du produit conformément au manuel de l'USCPSC. Une copie de cette section peut être trouvée dans l'Appendice X2.

6. Observer les déclarations et avertissements suivants réduit la probabilité de blessure grave ou mortelle.

7. Préciser le nombre et le poids des occupants qui peuvent utiliser l'équipement en toute sécurité, seuls ou simultanément.

8. Recommander la surveillance d'un adulte sur place pour les enfants de tous âges.

9. Avertir le propriétaire d'instruire les enfants à ne pas utiliser l'équipement de manière non prévue.

10. Avertir le propriétaire d'instruire les enfants à ne pas descendre de l'équipement lorsqu'il est en mouvement.

11. Avertir le propriétaire de ne pas laisser les enfants porter des objets inappropriés, tels que, mais sans s'y limiter, des vêtements amples, des capuches et des cordons au cou, des écharpes, des objets attachés par des cordons, des capes et des ponchos. Ces objets peuvent causer la mort par strangulation.

12. Avertir le propriétaire d'instruire les enfants à ne pas grimper lorsque l'équipement est mouillé.

13. Avertir le propriétaire d'instruire les enfants à ne pas attacher d'objets à l'équipement de jeux qui ne sont pas spécifiquement conçus pour être utilisés avec l'équipement, tels que, mais sans s'y limiter, des cordes à sauter, des cordes à linge, des laisses pour animaux, des câbles et des chaînes, car ils peuvent présenter un risque de strangulation.

14. Avertir le propriétaire d'instruire les enfants à retirer leur casque de vélo ou autre casque de sport avant de jouer sur l'équipement de jeux.

15. Avertir le propriétaire de vêtir les enfants avec des chaussures bien ajustées et couvrant entièrement les pieds.

Exemples de chaussures inappropriées : sabots, tongs et sandales.

16. Placer l'équipement sur un sol plat, à au moins 6 pieds (1,8 m) de toute structure ou obstacle comme une clôture, un garage, une maison, des branches surplombantes, des fils à linge ou des câbles électriques.

17. Ne pas installer les équipements de jeux pour la maison sur du béton, de l'asphalte, de la terre compactée, de l'herbe, de la moquette ou toute autre surface dure. Une chute sur une surface dure peut entraîner des blessures graves ou la mort de l'utilisateur de l'équipement.

18. Pour éviter les blessures graves, des mentions d'avertissement doivent être incluses pour avertir que les enfants ne doivent pas utiliser l'équipement avant qu'il ne soit correctement installé.



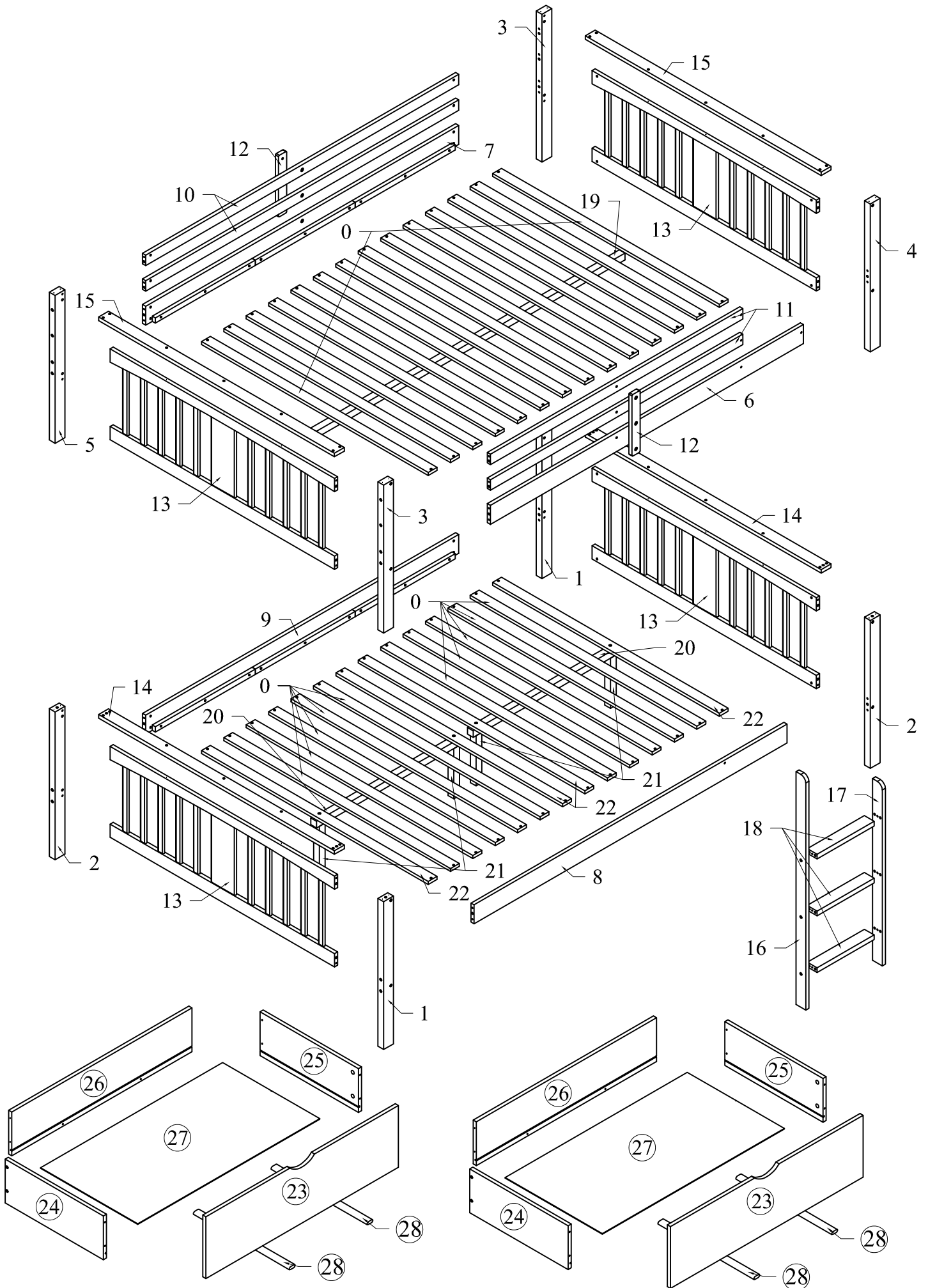

ASSEMBLY INSTRUCTION

INSTRUCTIONS DE MONTAGE

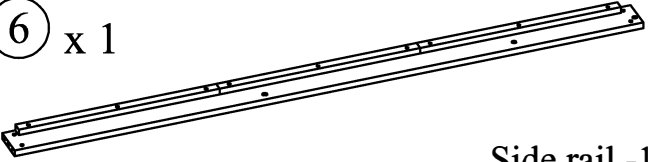
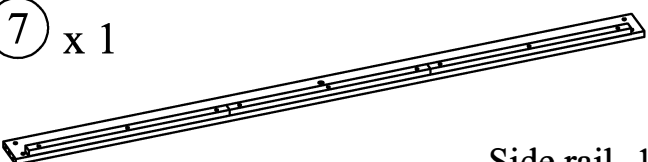
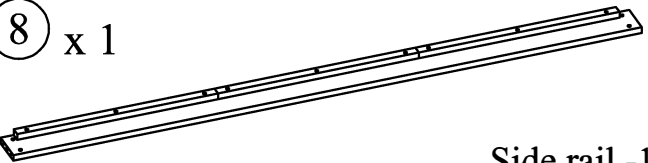
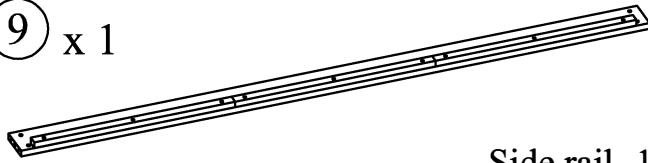
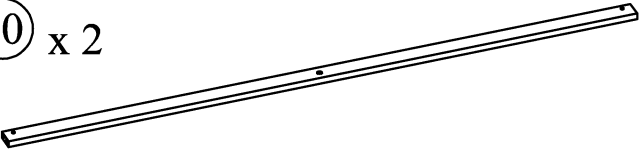
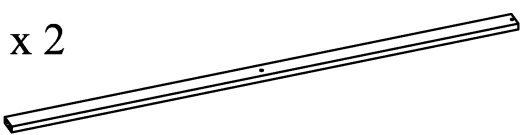

Part List & Hardware List (Box 1)

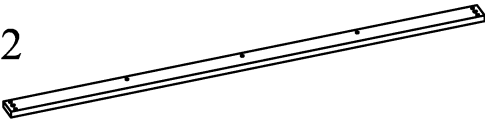
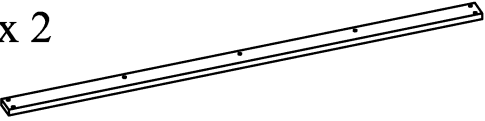
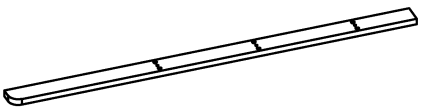
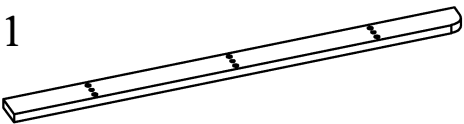
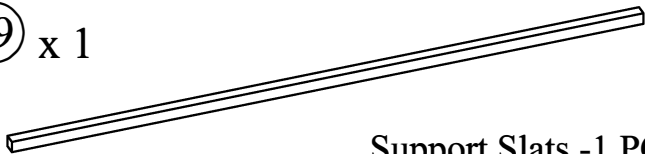
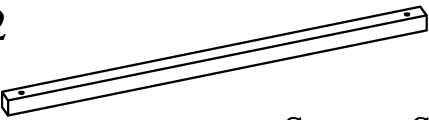
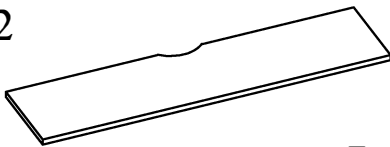
Liste des pièces & Liste du matériel (boîte 1)

<p>⑥ x 1</p>  <p>Side rail -1 PC Barrière latérale</p>	<p>⑦ x 1</p>  <p>Side rail -1 PC Barrière latérale</p>
<p>⑧ x 1</p>  <p>Side rail -1 PC Barrière latérale</p>	<p>⑨ x 1</p>  <p>Side rail -1 PC Barrière latérale</p>
<p>⑩ x 2</p>  <p>Crossbar - 2PCS Barre transversale</p>	<p>⑪ x 2</p>  <p>Crossbar - 2PCS Barre transversale</p>
<p>⑫ x 2</p>  <p>Railing support bar - 2PCS Barre de support de garde-corps</p>	<p>⑭ x 2</p>  <p>Crossbar - 2PCS Barre transversale</p>
<p>⑮ x 2</p>  <p>Crossbar - 2PCS Barre transversale</p>	<p>⑯ x 1</p>  <p>Stair side bar -1 PC Barre latérale d'escalier</p>
<p>⑰ x 1</p>  <p>Stair side bar -1 PC Barre latérale d'escalier</p>	<p>⑲ x 1</p>  <p>Support Slats -1 PC Lattes de support</p>
<p>⑳ x 2</p>  <p>Support Slats -2 PCS Lattes de support</p>	<p>㉓ x 2</p>  <p>Front Drawer Tiroir avant</p>
<p>㉔ x 2</p>  <p>Side Drawer Tiroir latéral</p>	<p>㉕ x 2</p>  <p>Side Drawer Tiroir latéral</p>

Part List & Hardware List (Box 1)

Liste des pièces & Liste du matériel (boîte 1)

26 x 2

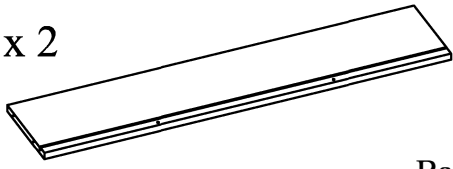



Back Drawer
Tiroir arrière

28 x 4





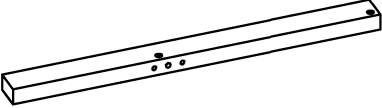
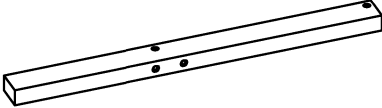
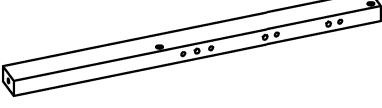
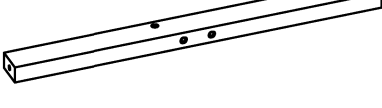
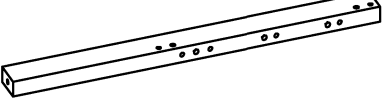
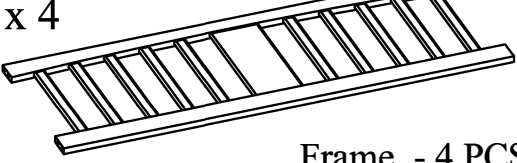

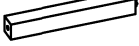
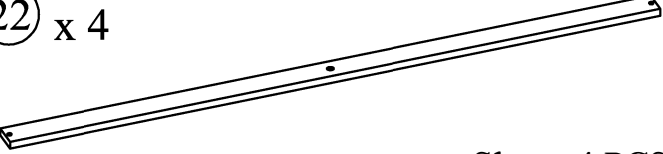
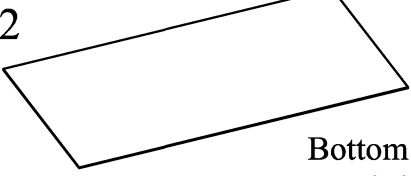
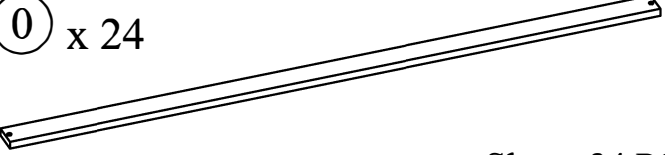















Support Drawer
Tiroir de support

Part List (Box 2)
Liste des pièces (boîte 2)

<p>① x 2</p>  <p>Leg -2 PCS Jambe</p>	<p>② x 2</p>  <p>Leg -2 PCS Jambe</p>
<p>③ x 2</p>  <p>Leg - 1 PC Jambe</p>	<p>④ x 1</p>  <p>Leg - 1 PC Jambe</p>
<p>⑤ x 1</p>  <p>Leg - 1 PC Jambe</p>	<p>⑬ x 4</p>  <p>Frame - 4 PCS Cadre</p>
<p>⑱ x 3</p>  <p>Stair - 3 PCS Marche</p>	<p>⑳ x 4</p>  <p>Leg Supports - 4 pcs Supports de jambe</p>
<p>㉒ x 4</p>  <p>Slats - 4 PCS Lattes</p>	<p>㉗ x 2</p>  <p>Bottom Drawer Tiroir du bas</p>
<p>① x 24</p>  <p>Slats - 24 PCS Lattes</p>	

Hardware List (Box 2)

Liste du matériel (boîte 2)

No.	OUTLOOK	DESC	QTY
(A)		Dowel Ø10*40mm Cheville	42
(B)		Bolts 1/4"*25mm Boulons	06
(C)		Bolts 1/4"*40mm Boulons	06
(D)		Bolts 1/4"*60mm Boulons	06
(E)		Bolts 1/4"*80mm Boulons	16
(F)		Bolts 1/4"*100mm Boulons	22
(G)		Cross dowel 1/4"*13mm Cheville croisée	44
(H)		Hex bolts 1/4"*15mm Boulons hexagonaux	06
(I)		Screws #8*30mm Des vis	74
(J)		Screws #8*35mm Des vis	28
(K)		Metal Dowel Ø10*100mm Cheville en métal	04
(L)		Allen key 60*22*4mm clé Allen	02
(M)		Bolts 1/4"*70mm Boulons	04
(N)		Round Head Screw #7*15mm Vis à tête ronde	08
(O)		Base U Base U	02
(P)		Wood stops Base U	03
(Q)		Connecting Bolt Boulon de connexion	08
(R)		Screws #6*12mm Des vis	40
(S)		Base L Base	04
(T)		Wheels roues	08

ASSEMBLY TOOLS REQUIRED (NOT INCLUDED)/OUTILS D'ASSEMBLAGE REQUIS (NON INCLUS)



STEP 1

Étape

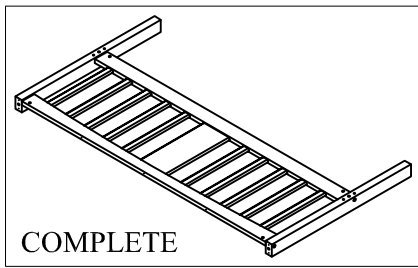

(A)		08
(E)		08
(G)		08

X2

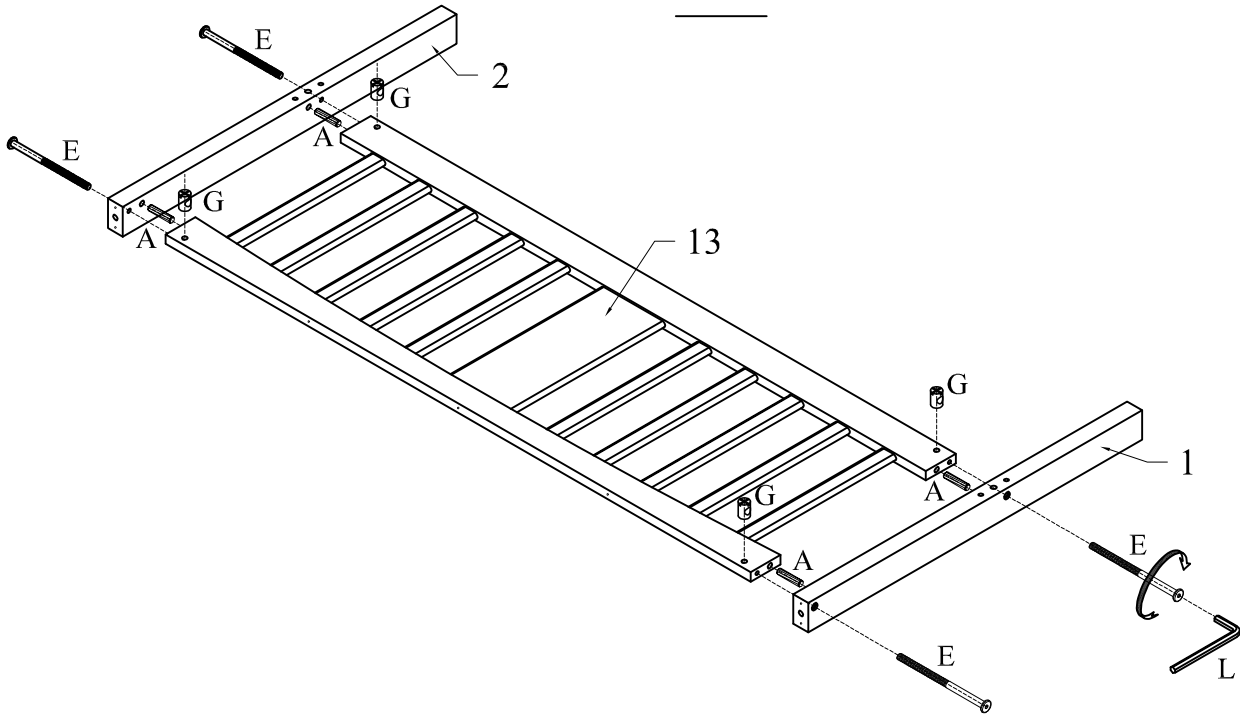

STEP 2

Étape

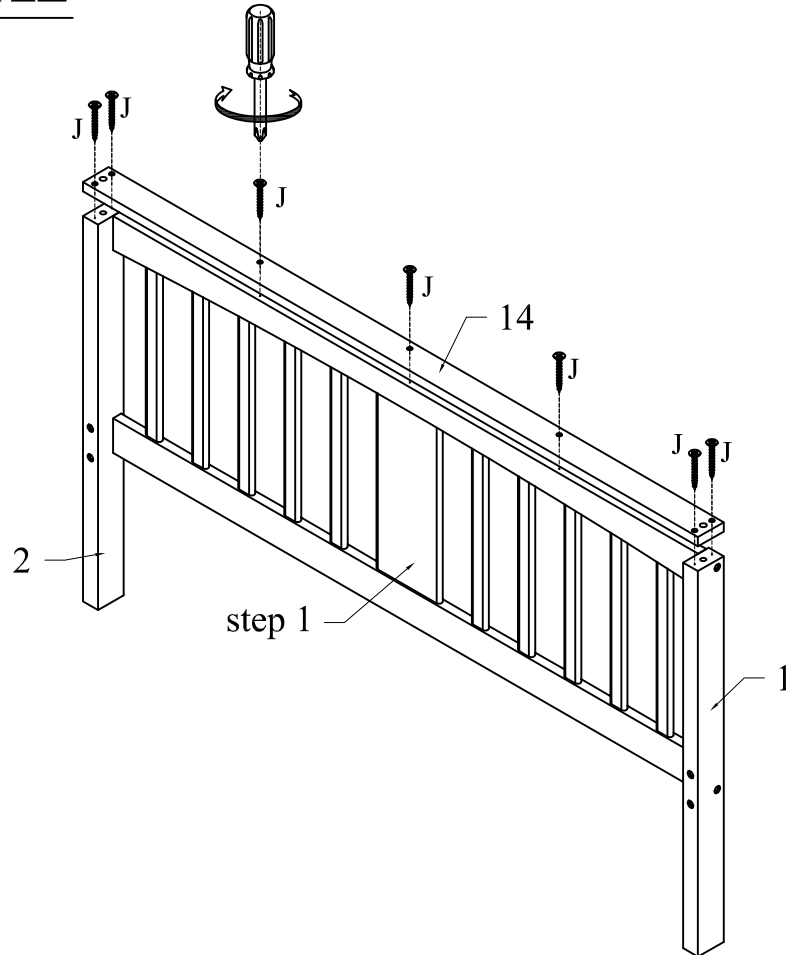
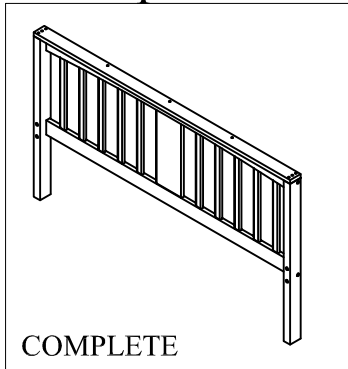

X2

(J)		14
-----	--	----

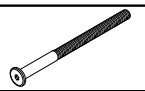

STEP 3

Étape

(A)		04
(F)		08
(G)		08

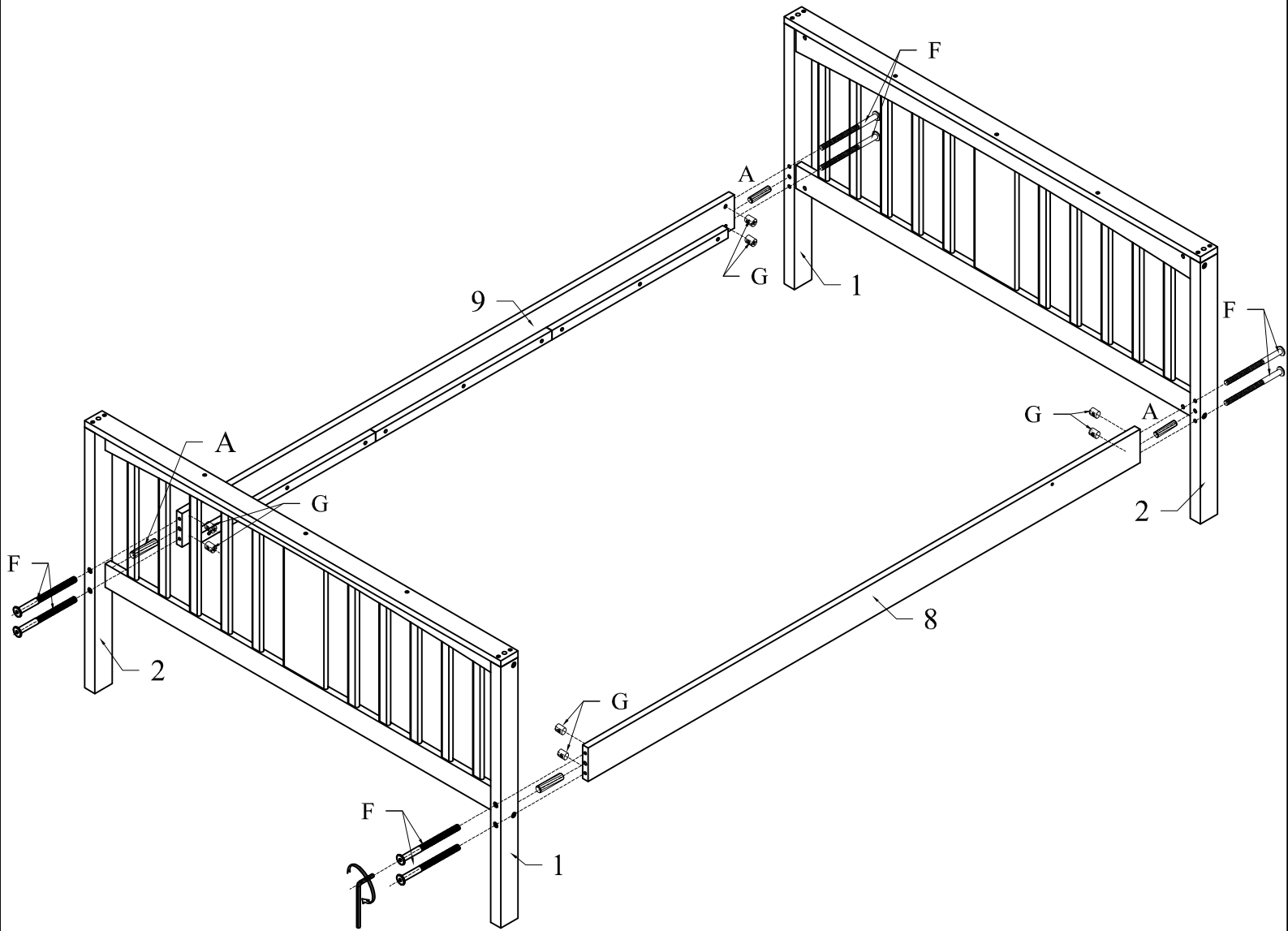
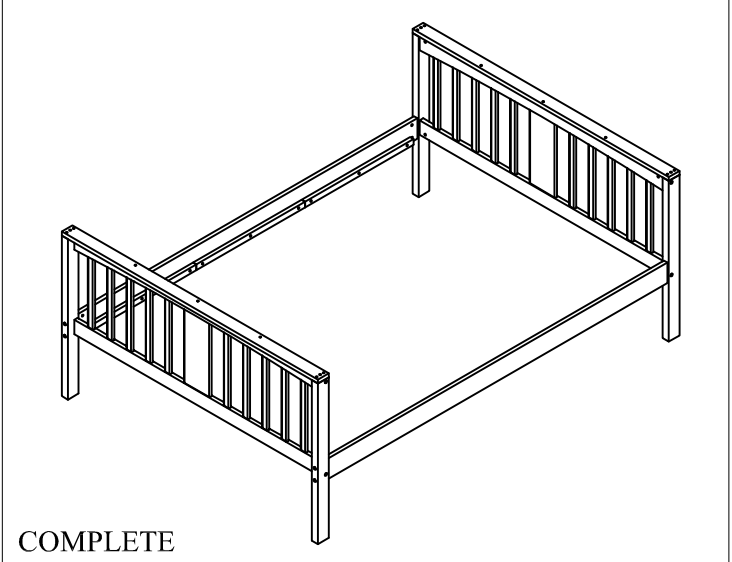

STEP 4

Étape

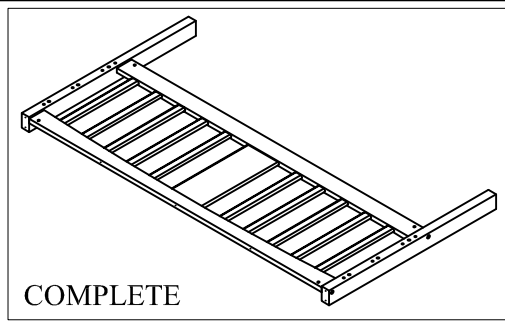

(A)		04
(E)		04
(G)		04

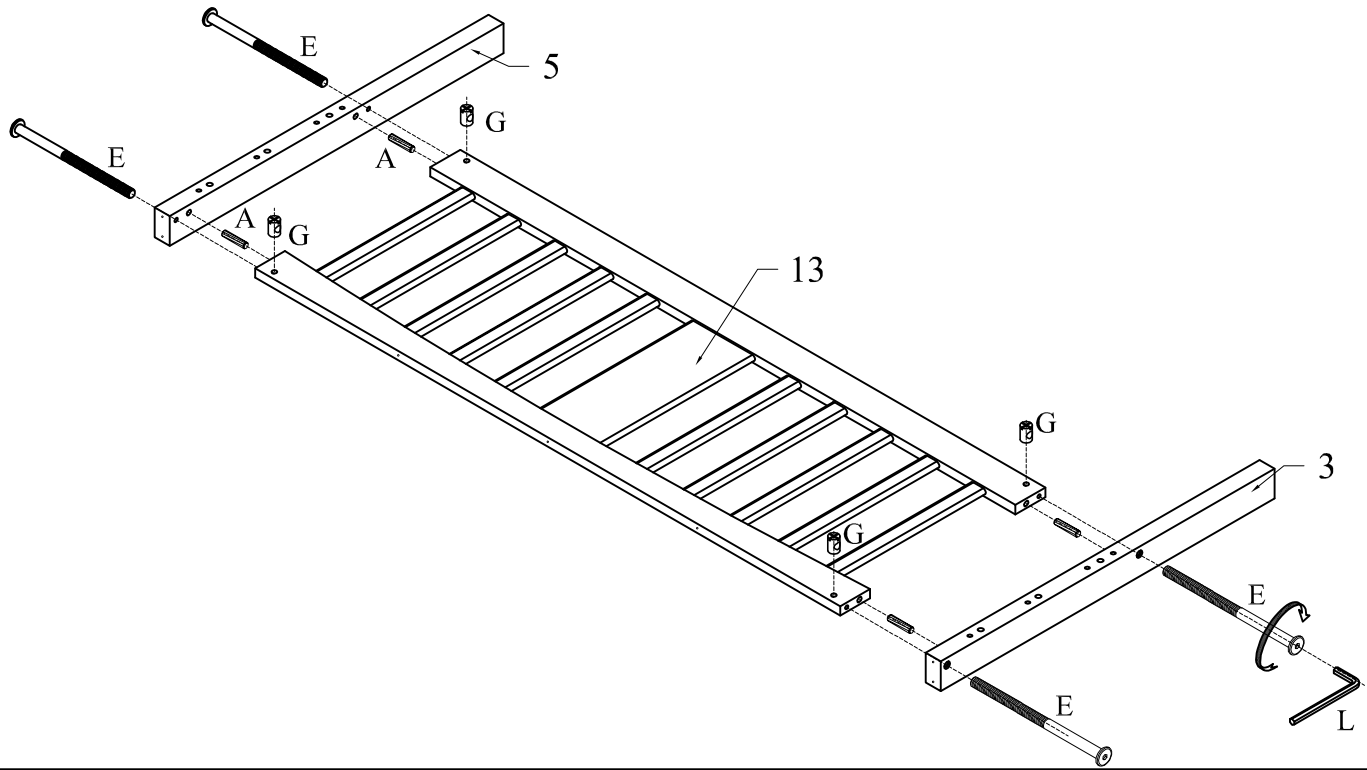

STEP 5

Étape

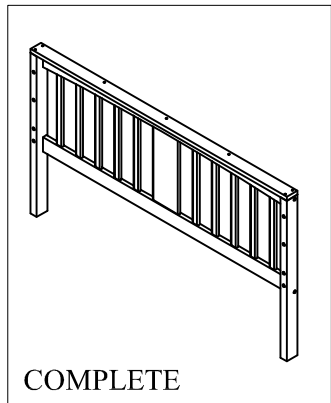

(J)		07
-----	--	----

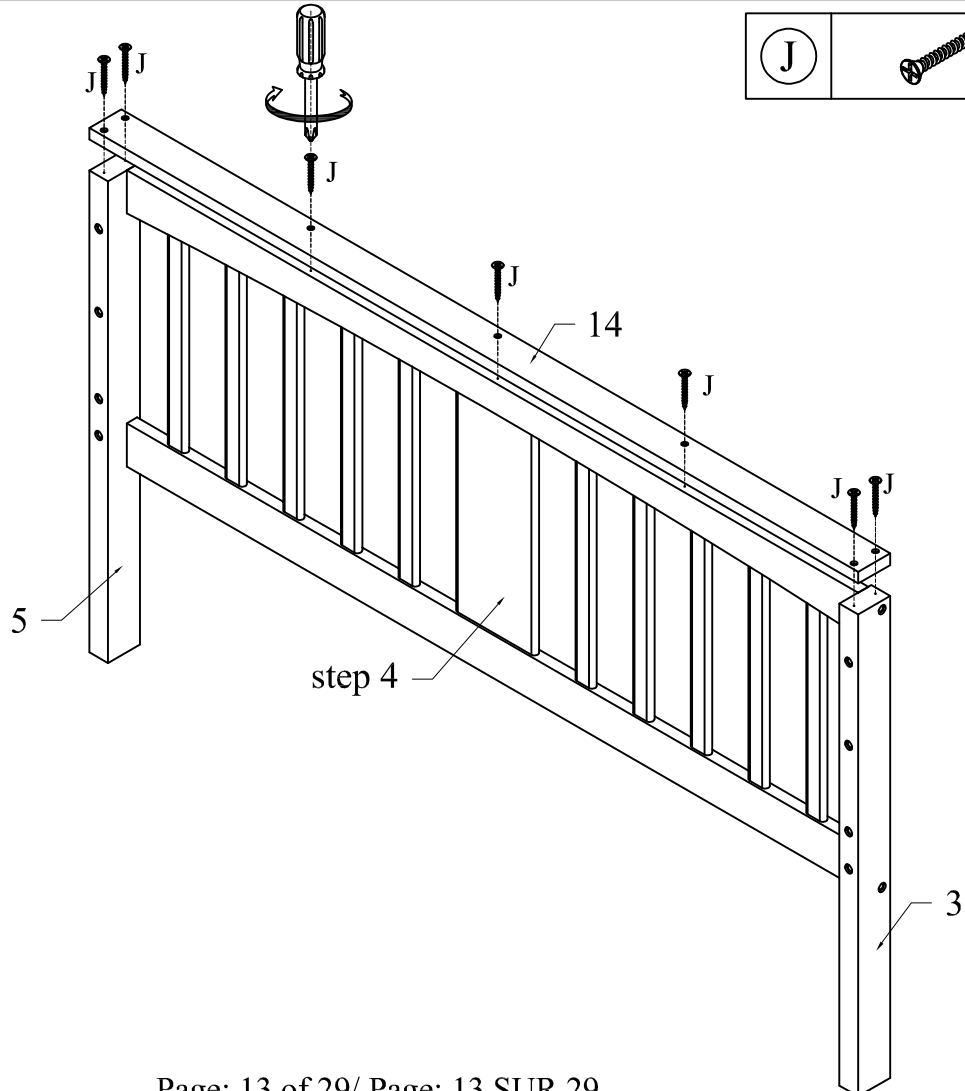

STEP 6

Étape

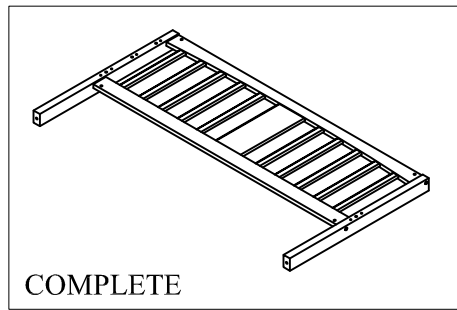

(A)		04
(E)		04
(G)		04

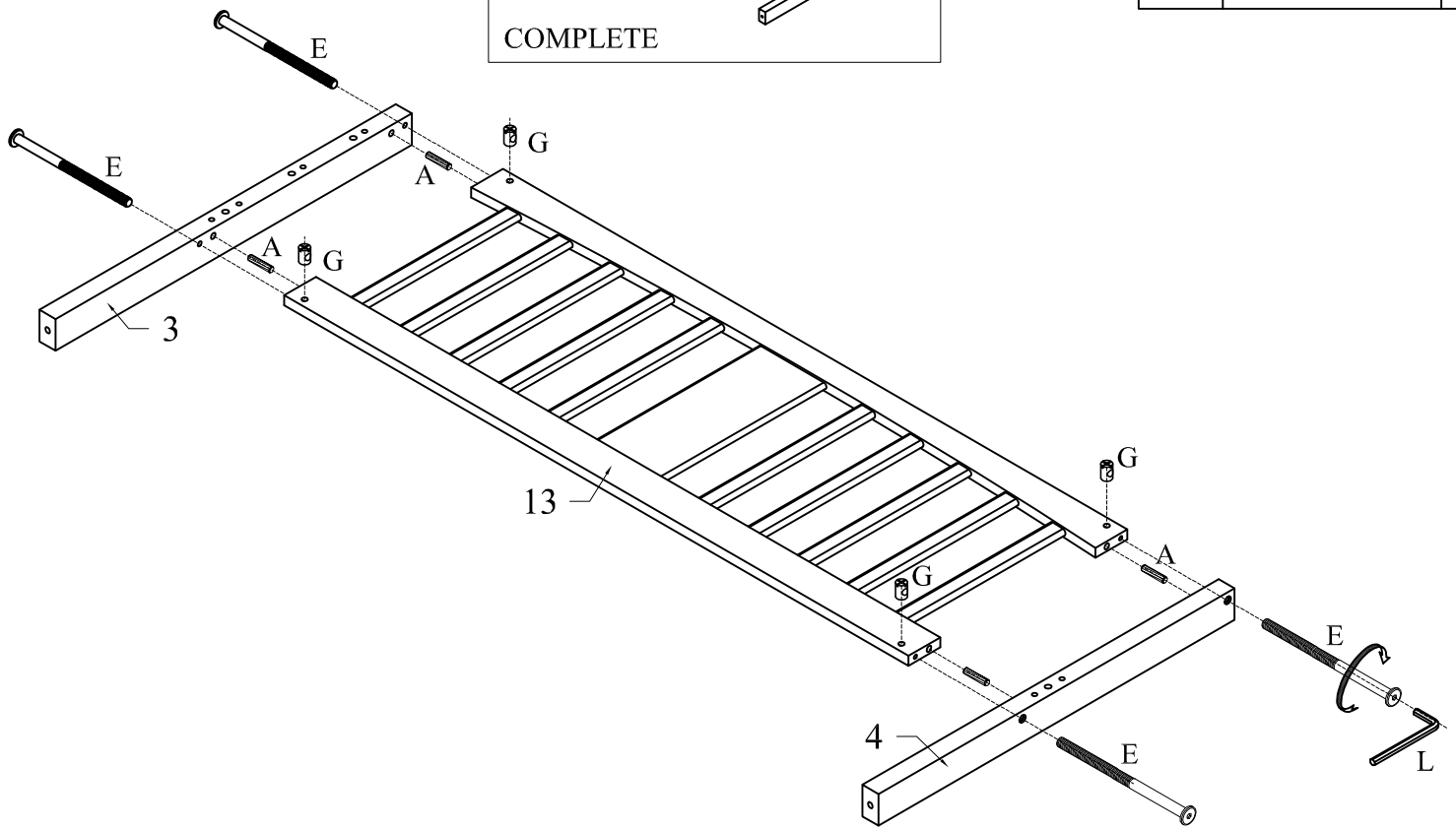

STEP 7

Étape

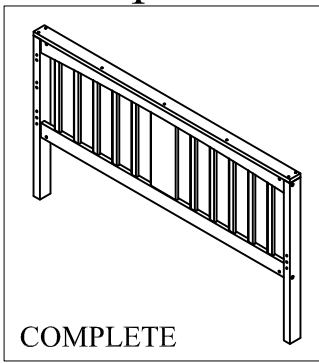

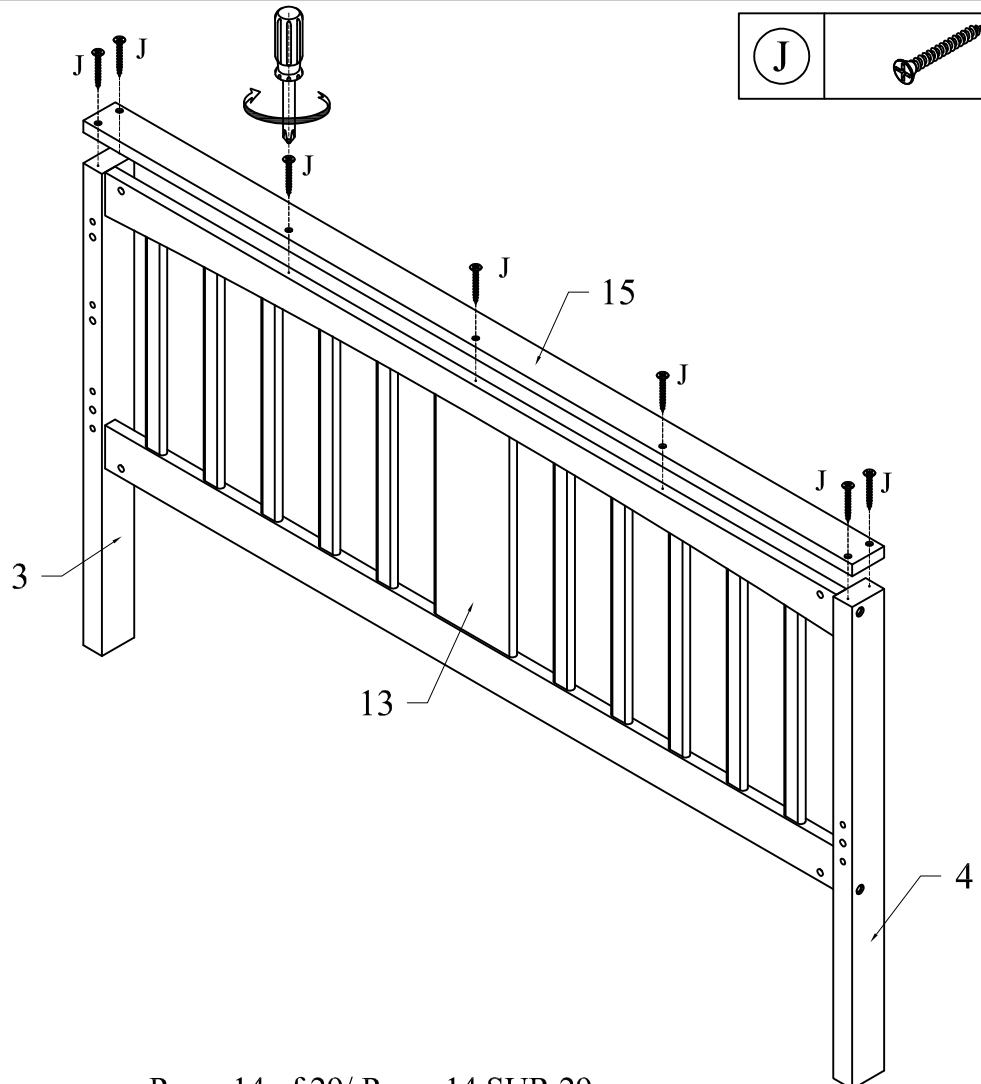

(J)		07
-----	--	----

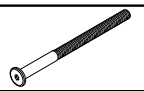

STEP 8

Étape

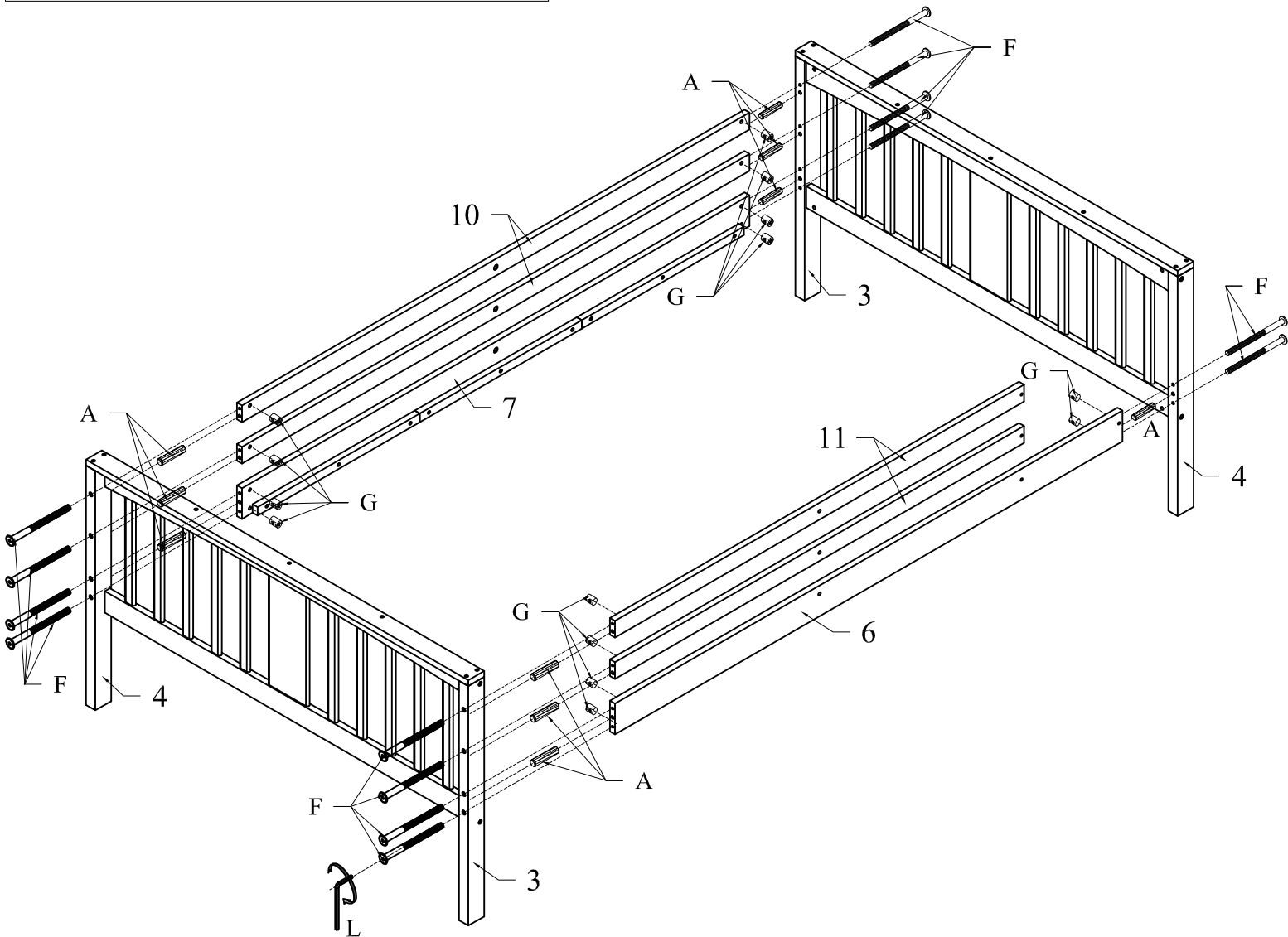
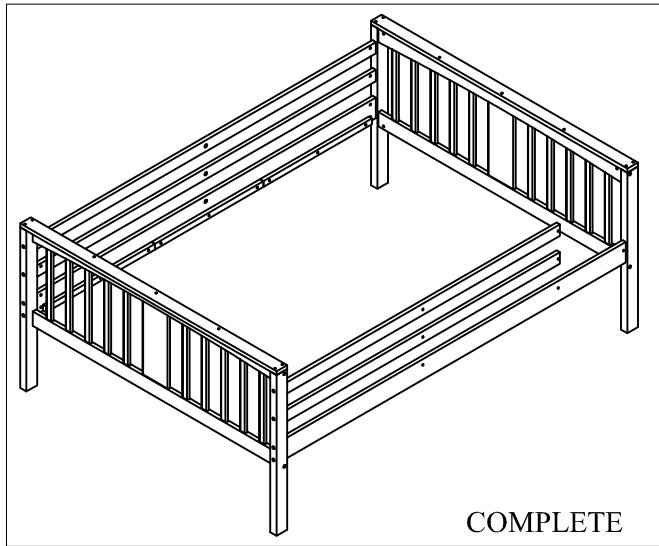

(A)		10
(F)		14
(G)		14

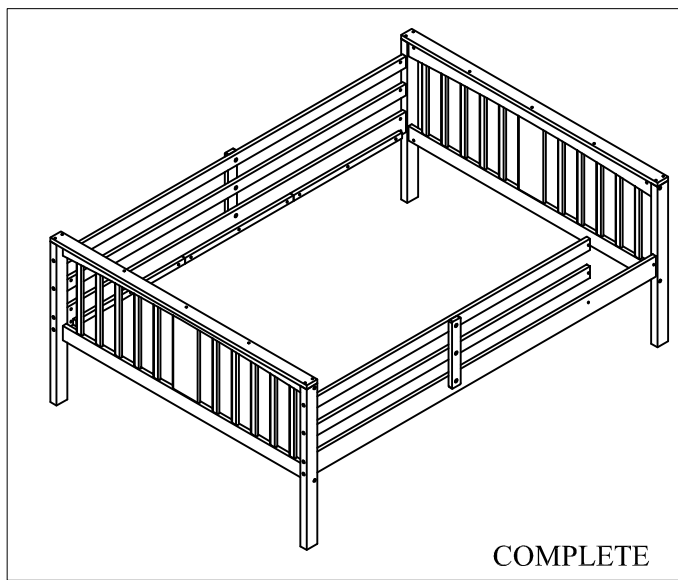

STEP 9

Étape



B		06
H		06

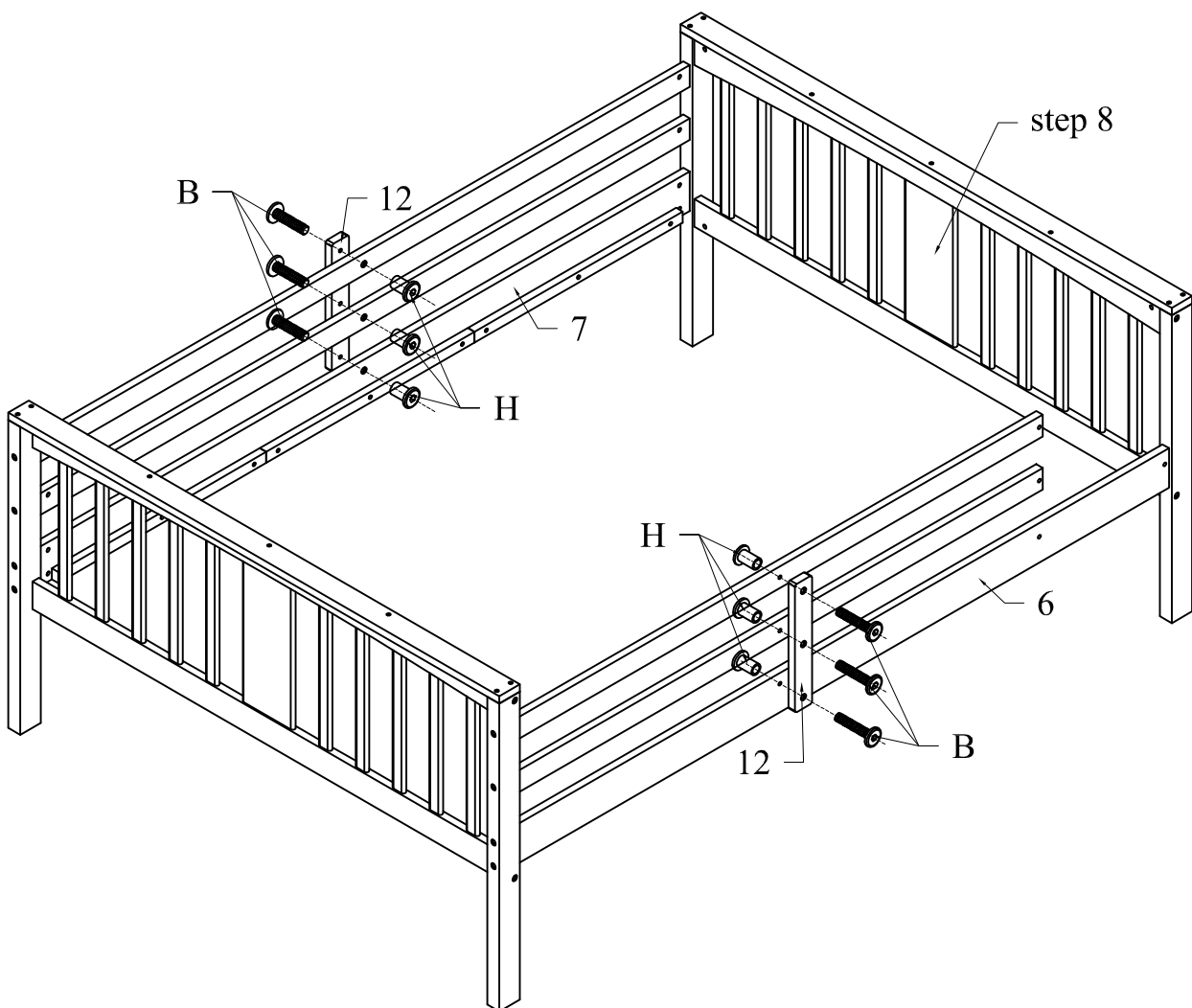

STEP 10

Étape

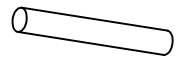
(K)		04
-----	---	----

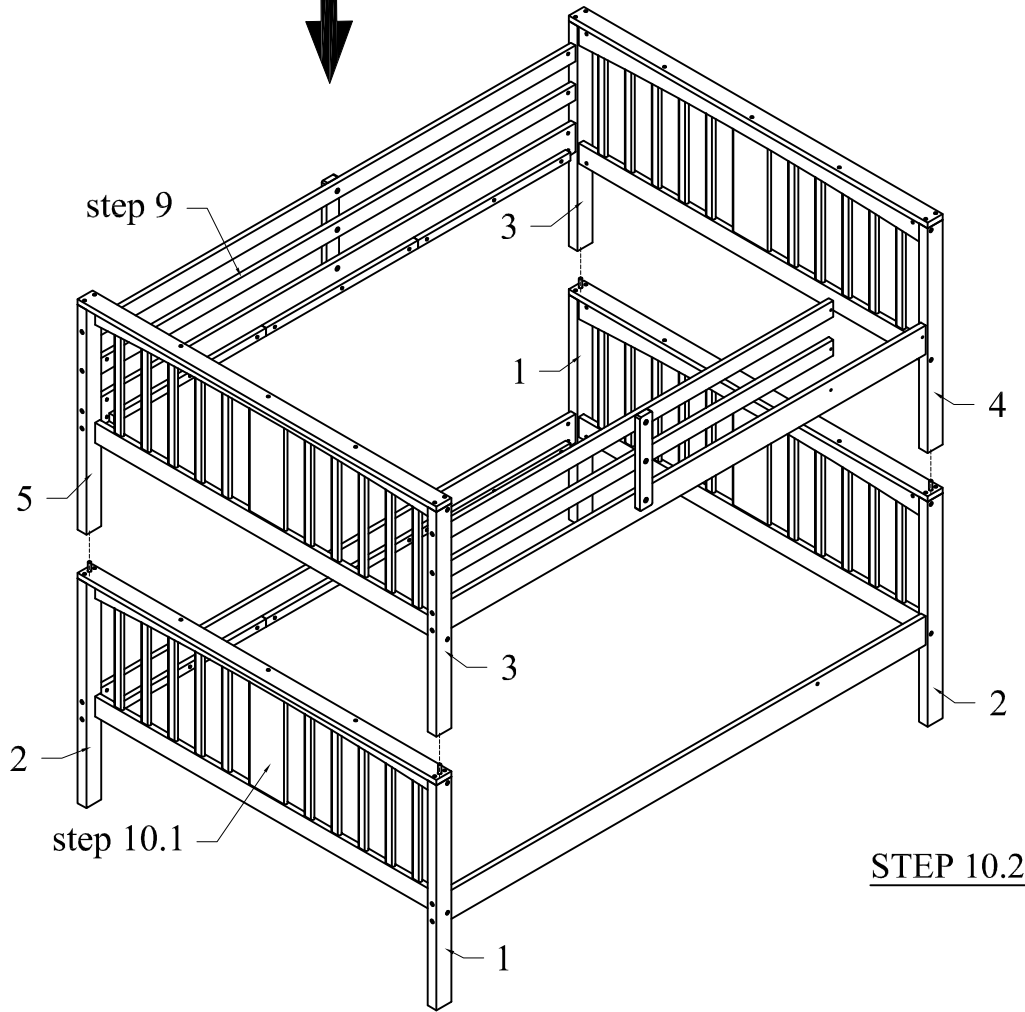
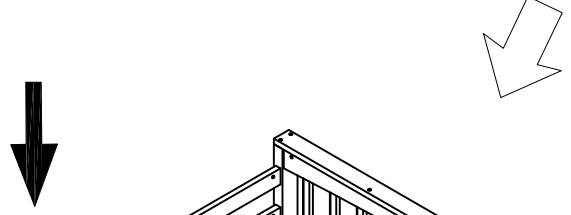
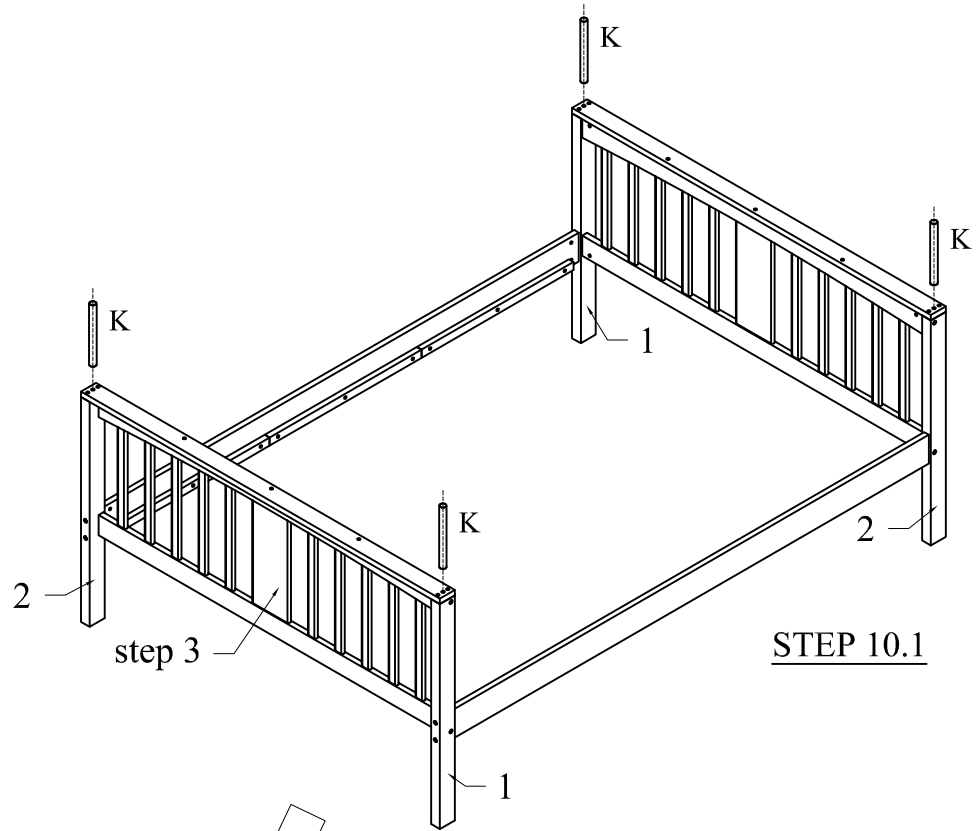
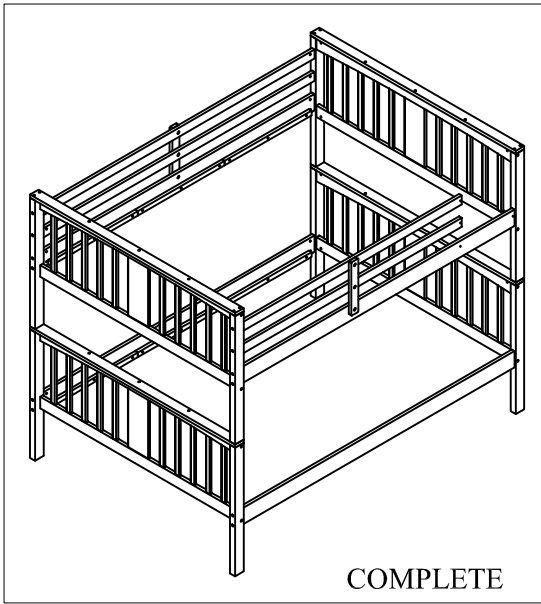

STEP 11

Étape

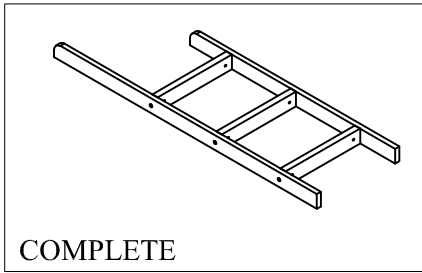

(A)		12
(D)		06
(G)		06

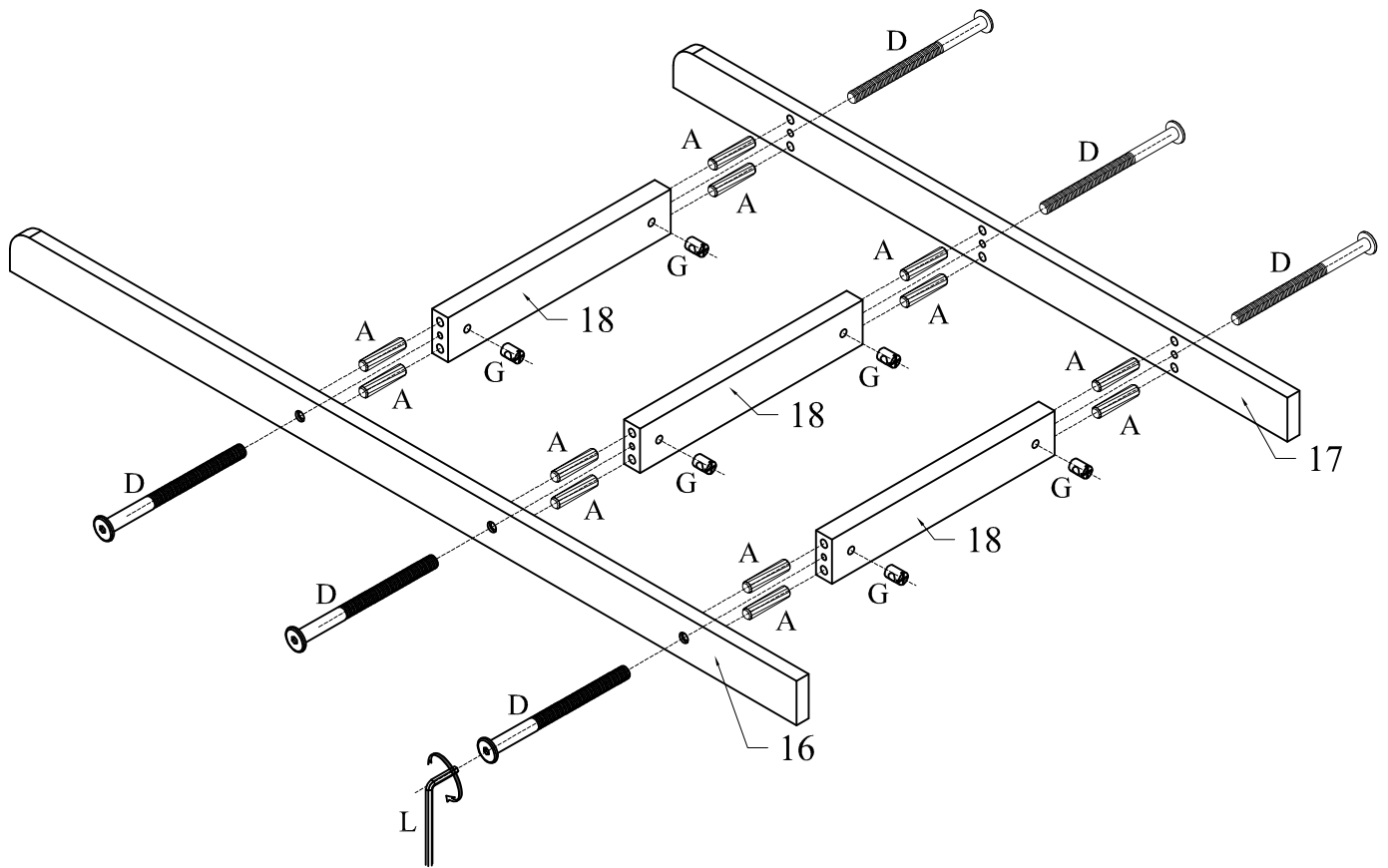

STEP 12

Étape

Ⓒ



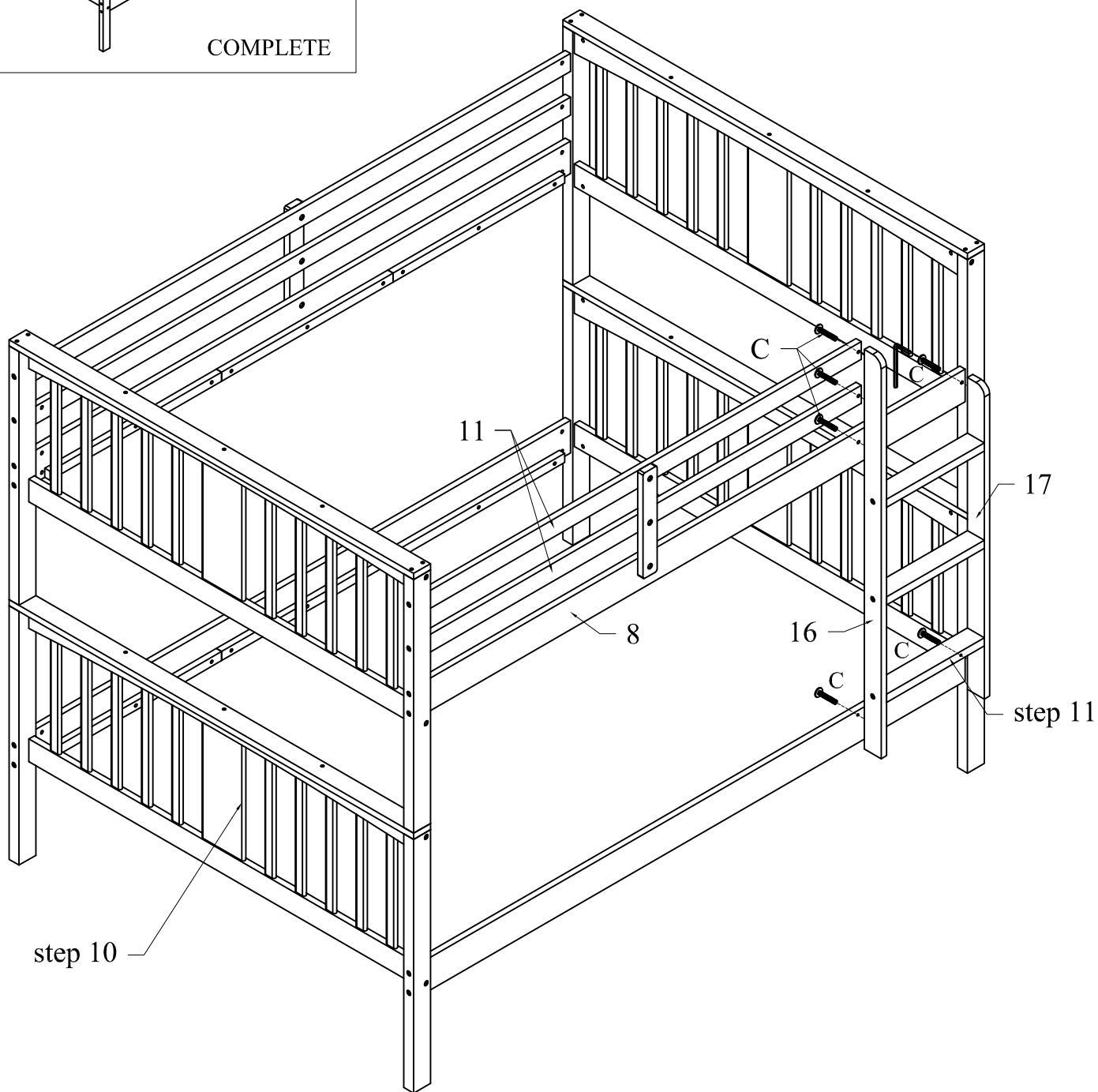
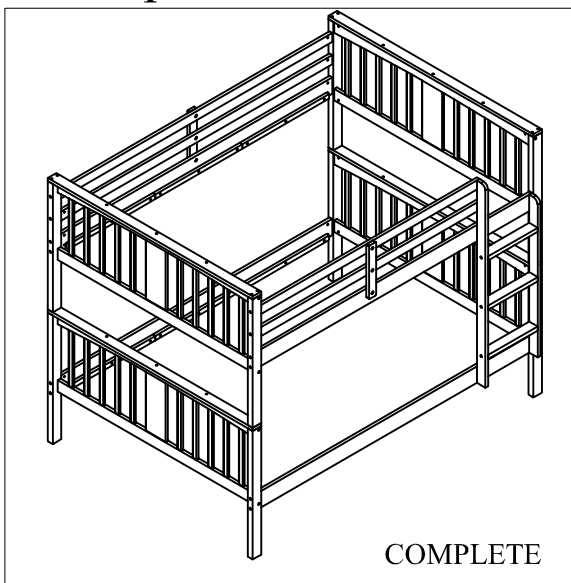

06



STEP 13

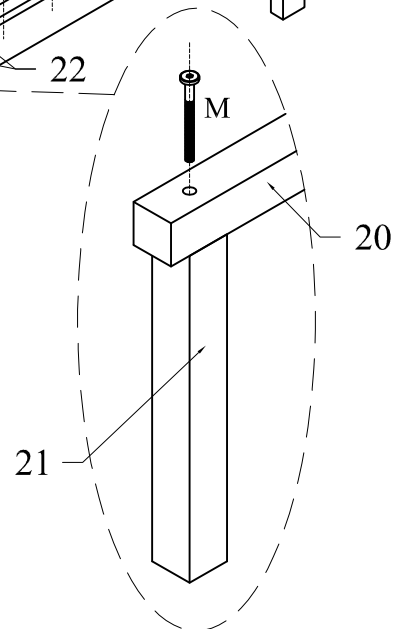
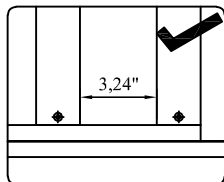
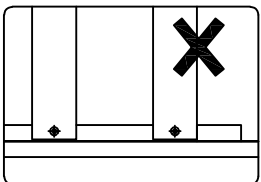
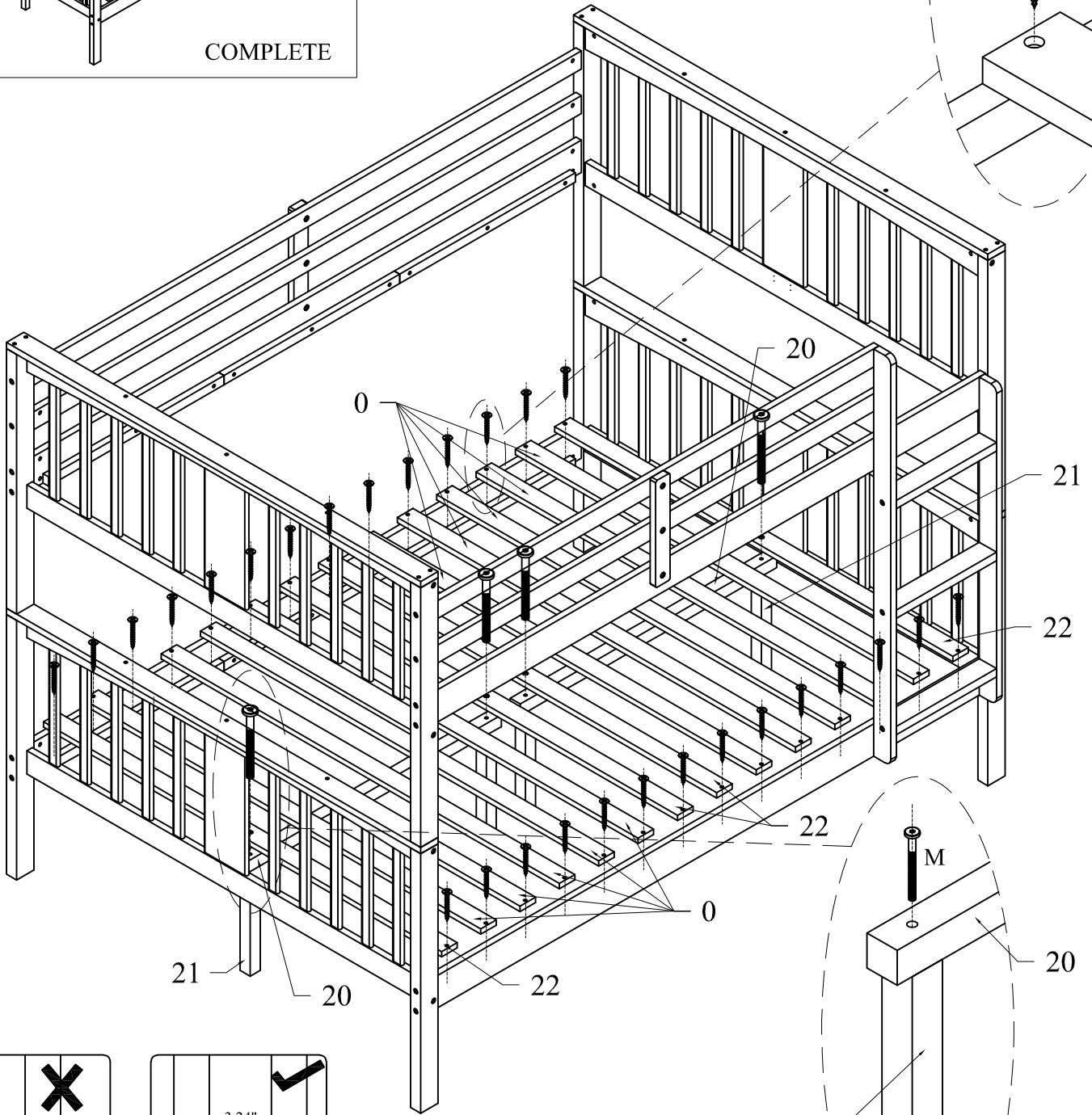
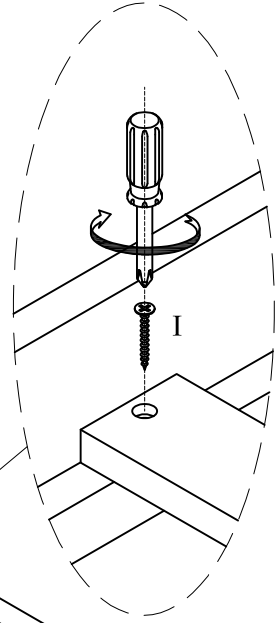
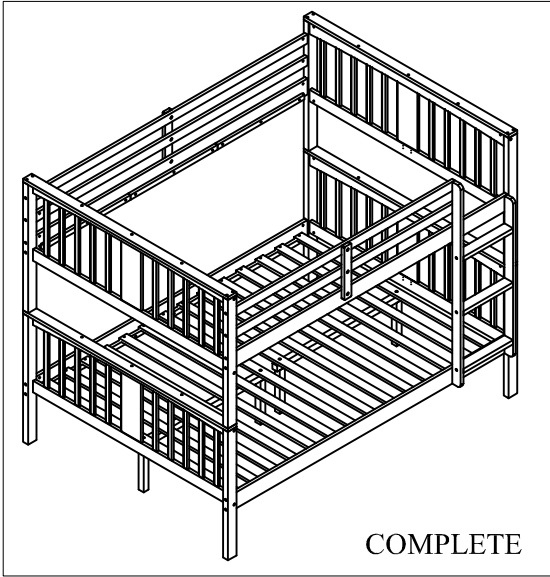

Étape

(I)		28
(M)		04



STEP 14

Étape

(N)		08
(O)		02

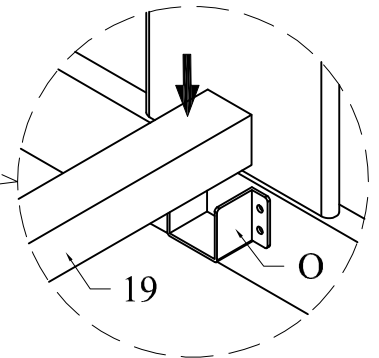
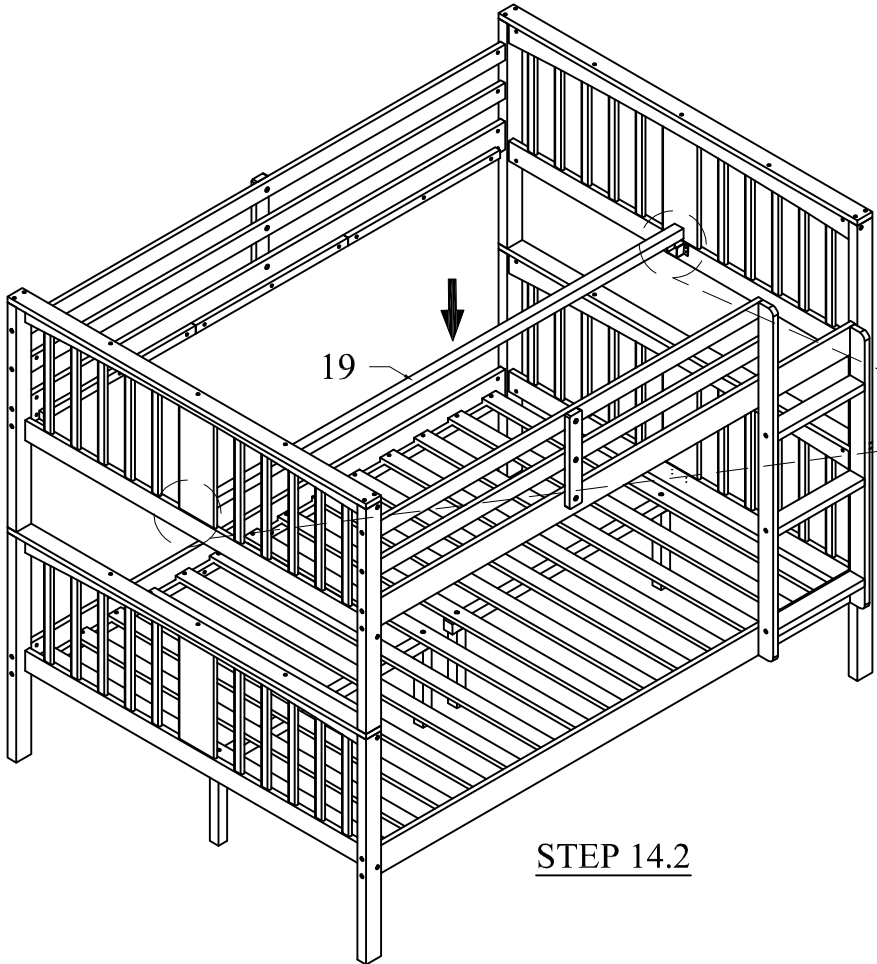
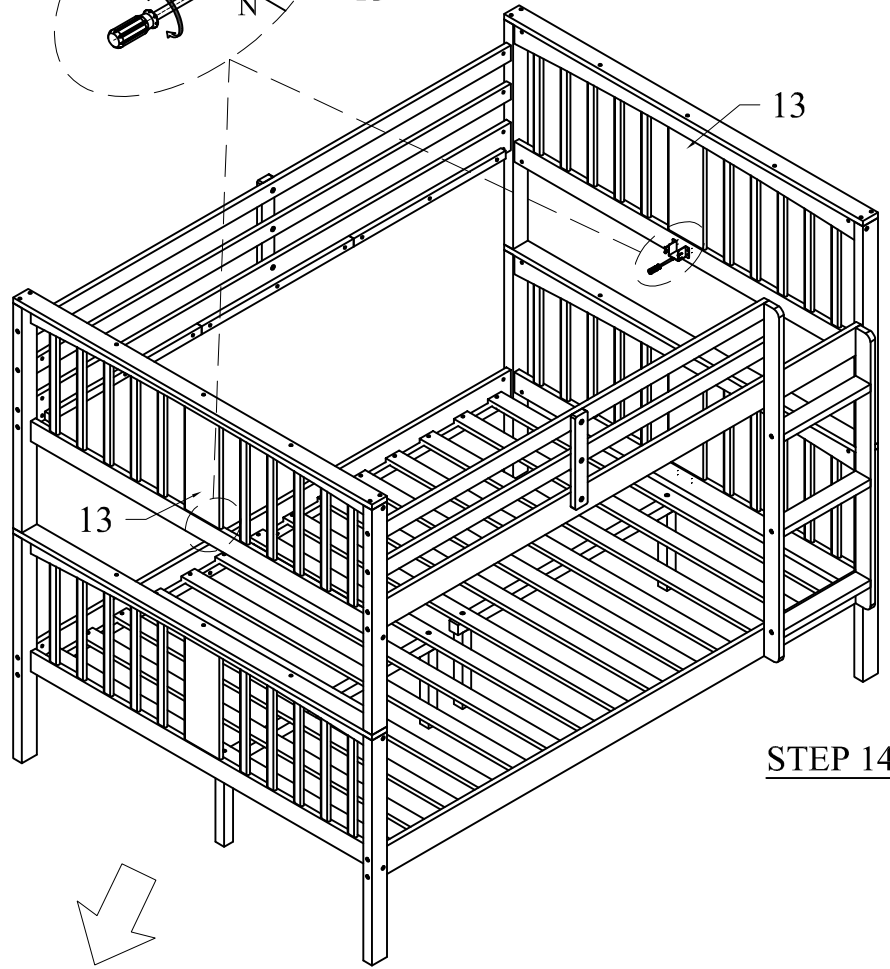
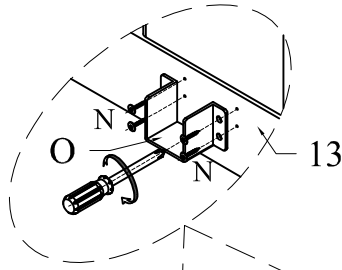
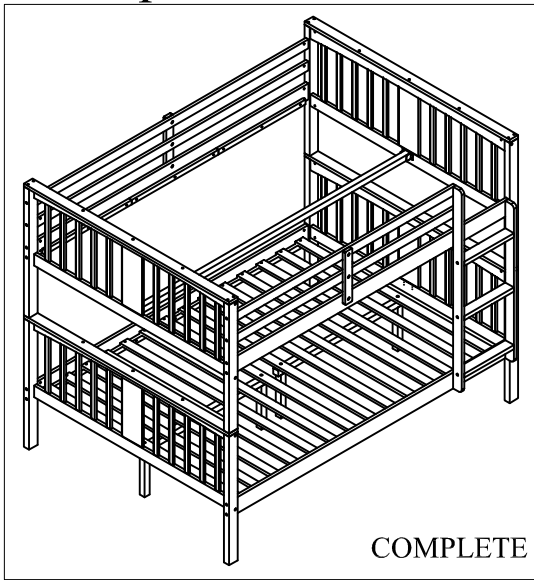

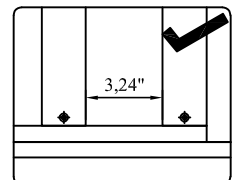
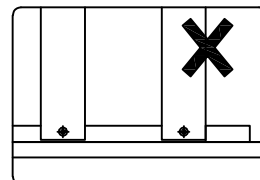
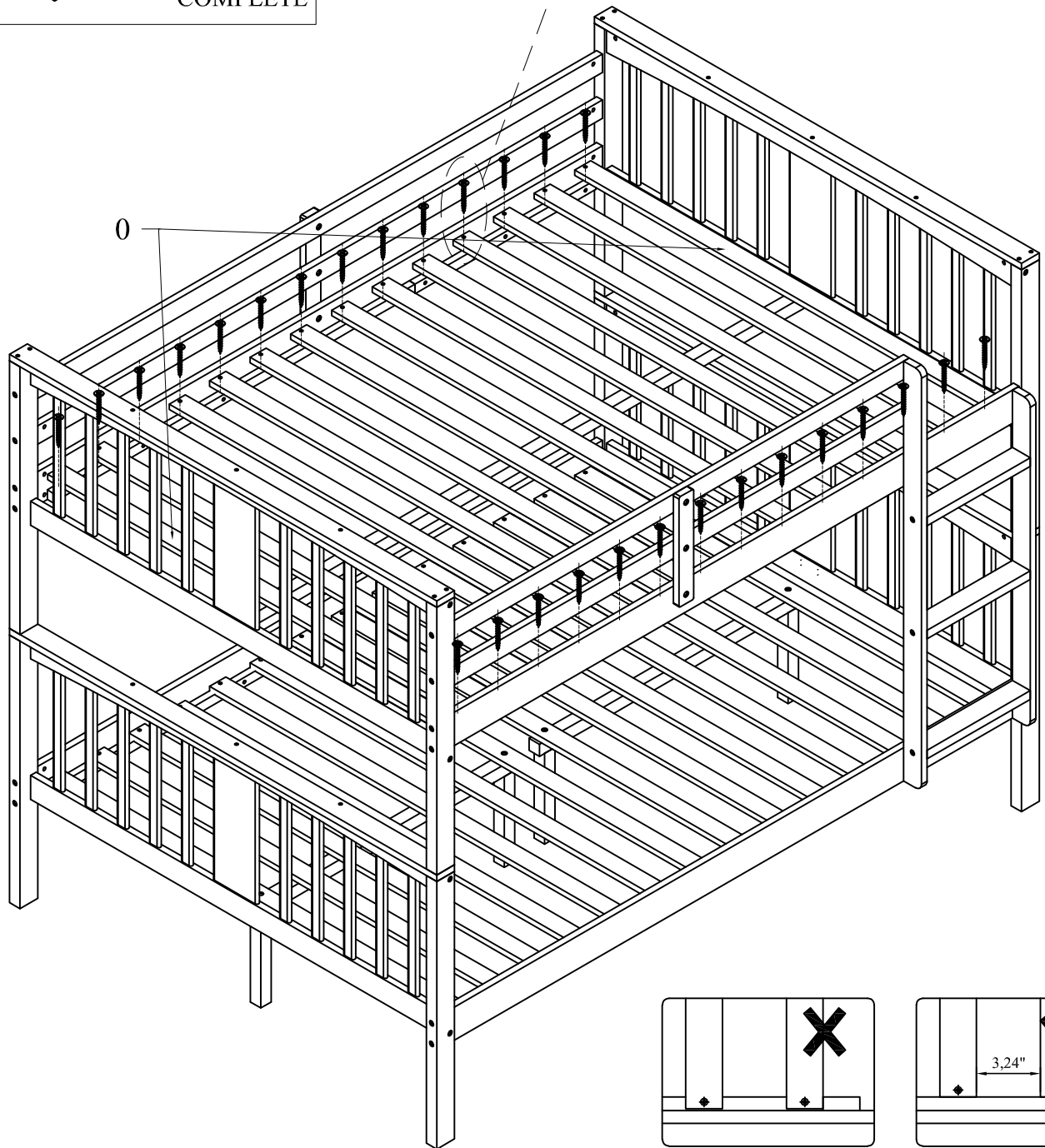
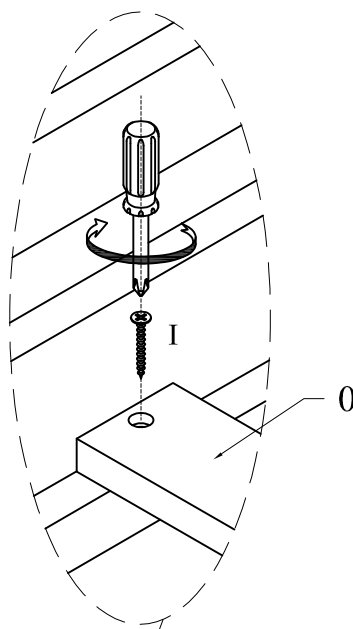
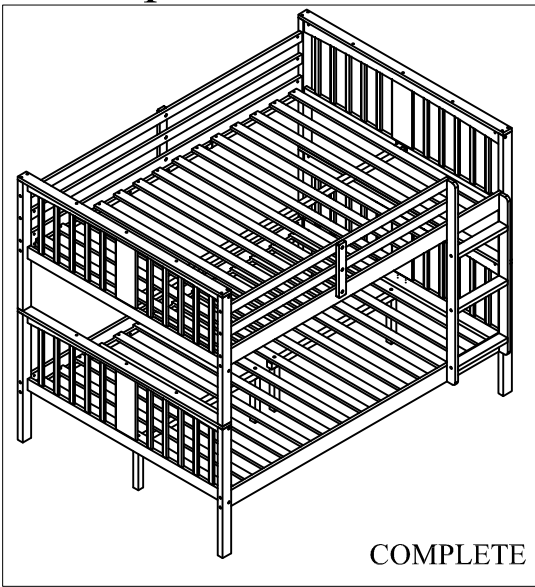

STEP 15

Étape



STEP 16

Étape

I		06
P		03

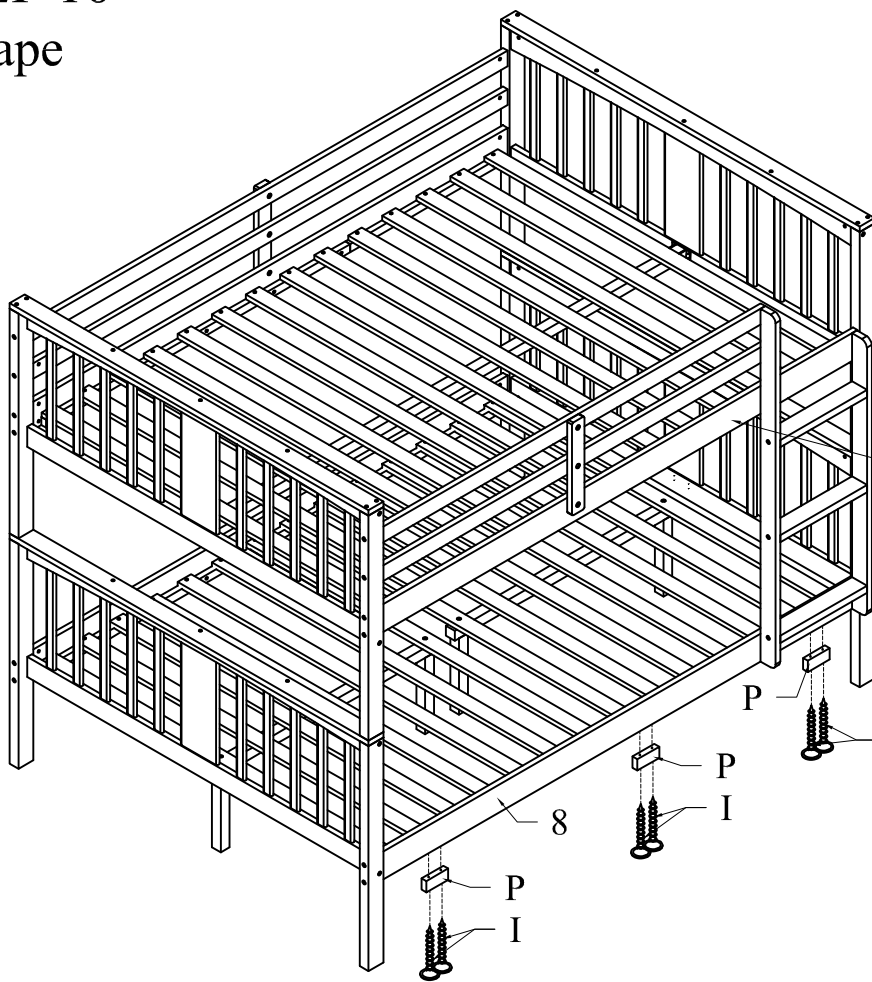

STEP 17

Étape

SCAN ME
SCANEZ-MOI

Assembly Video
Vidéo d'assemblage

Q		04
---	---	----

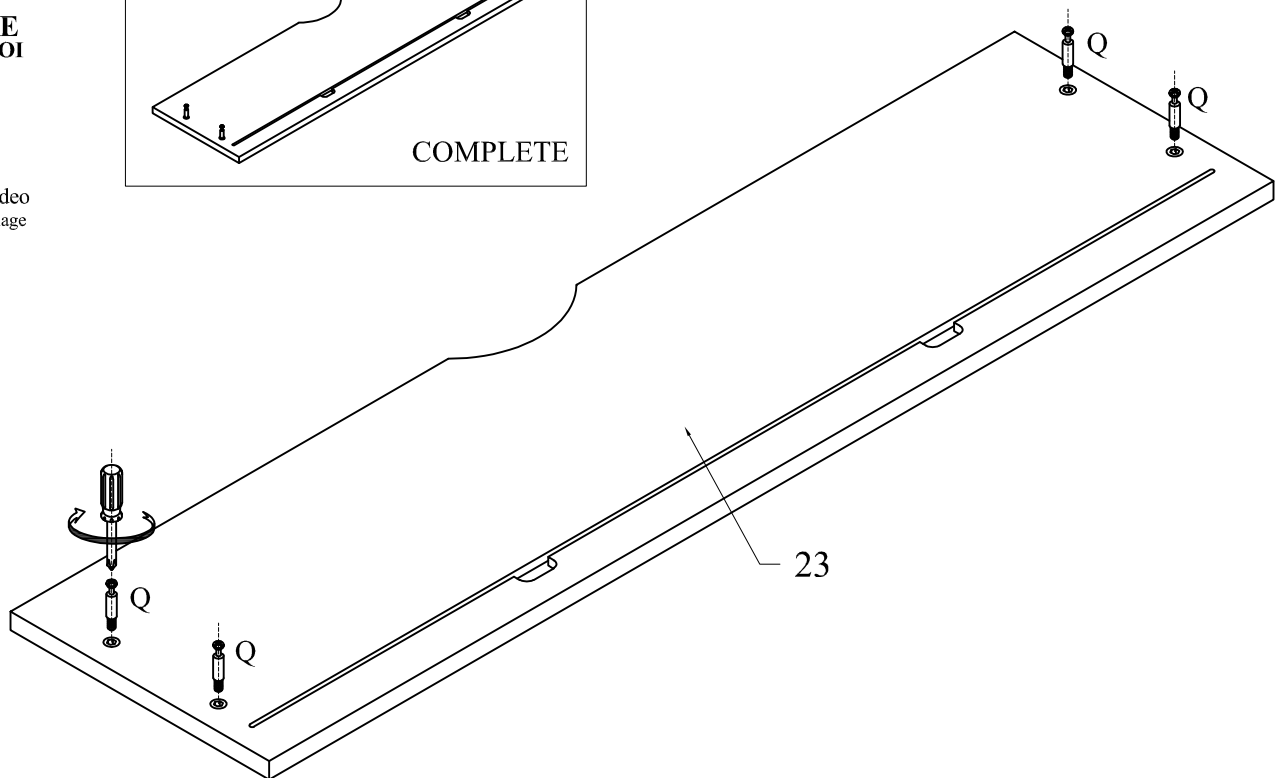
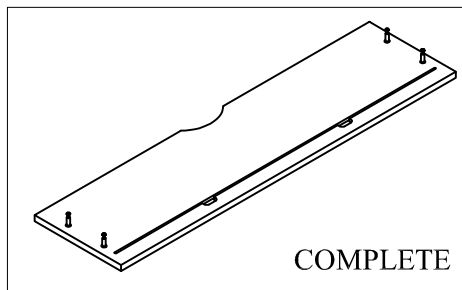

STEP 18
Étape

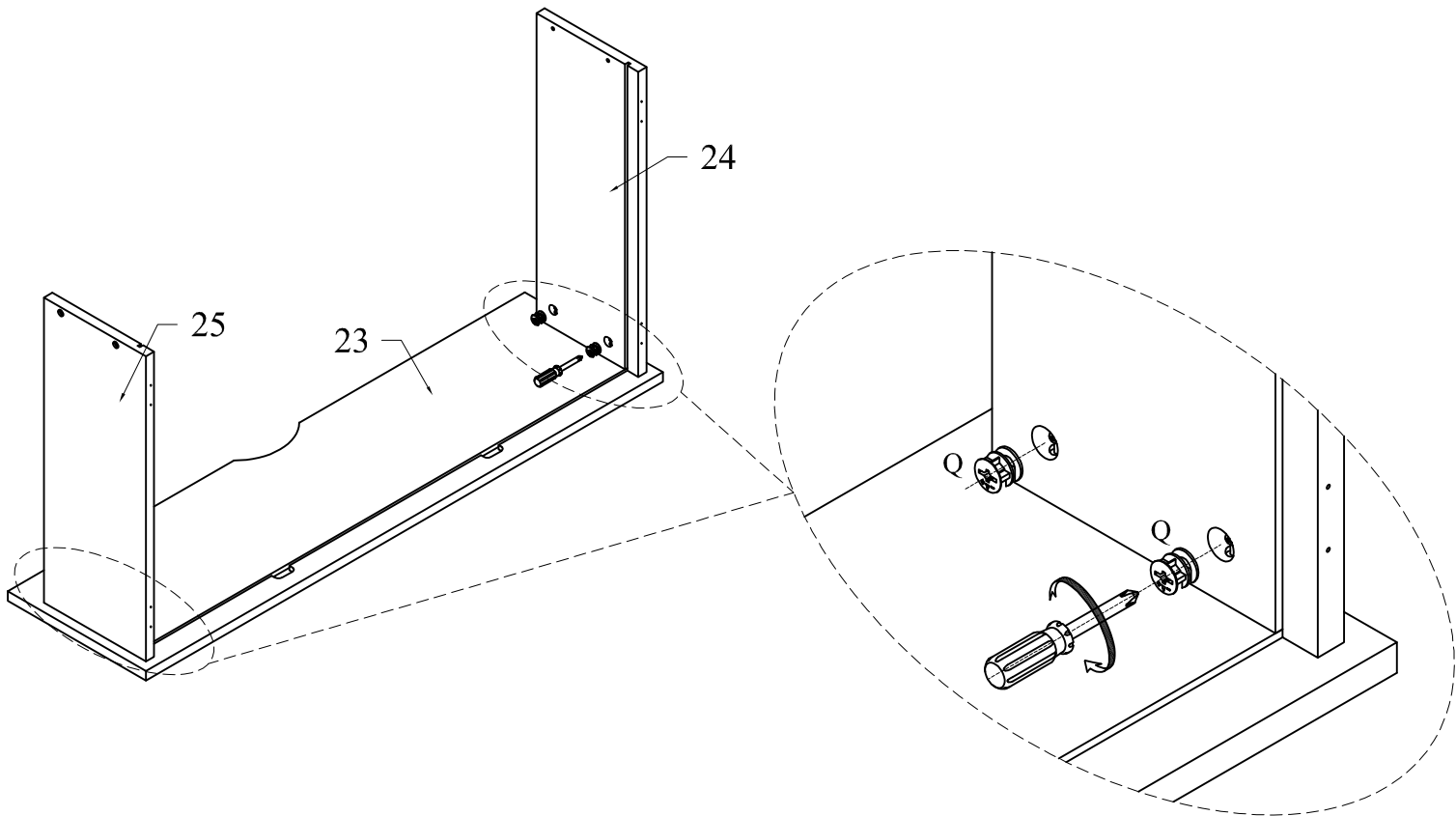
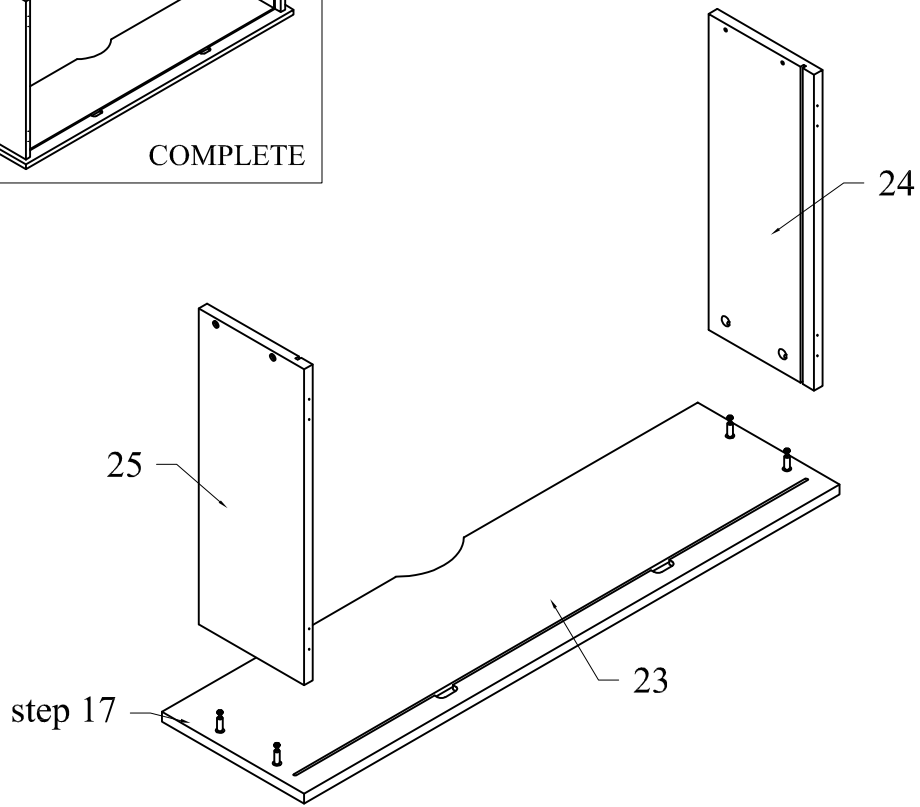
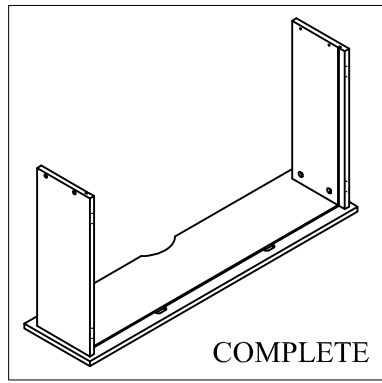

STEP 19

Étape

I



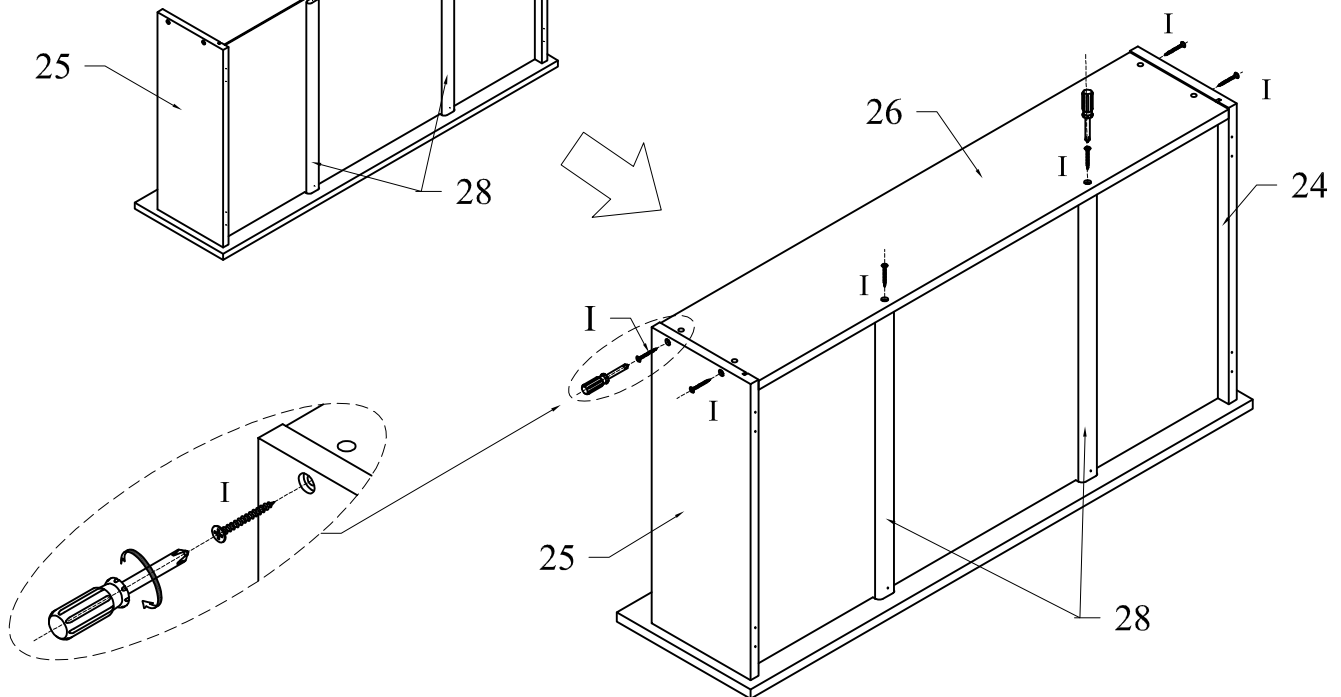
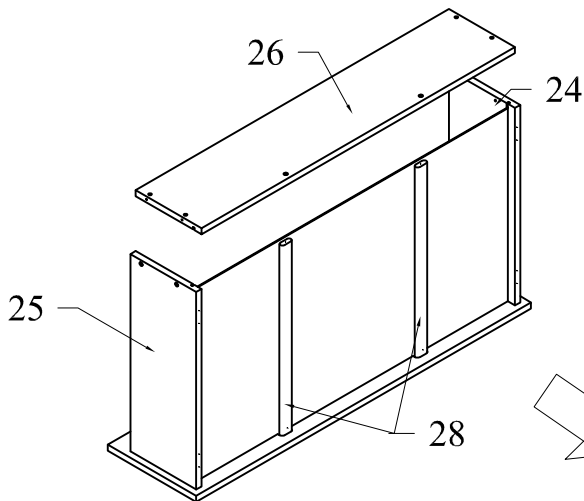
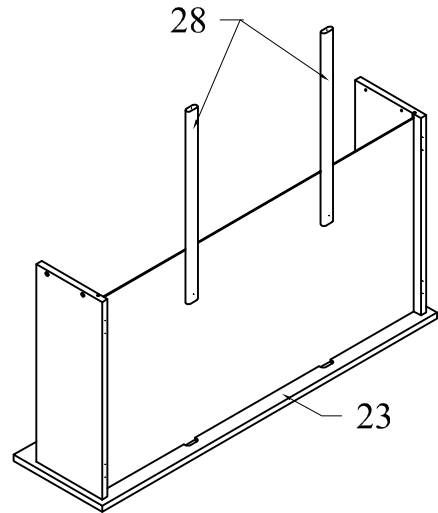
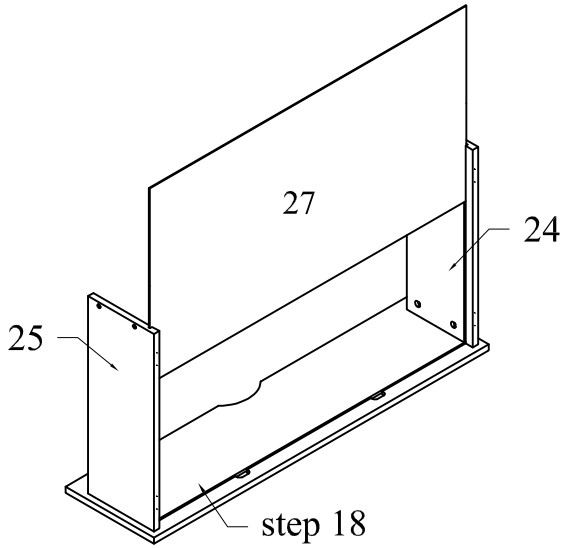
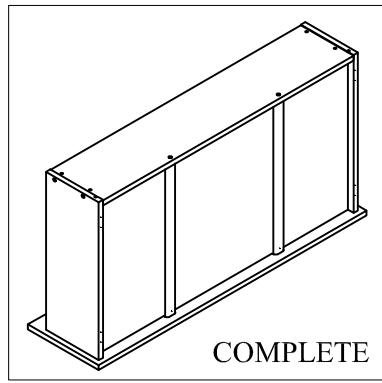

06



STEP 20

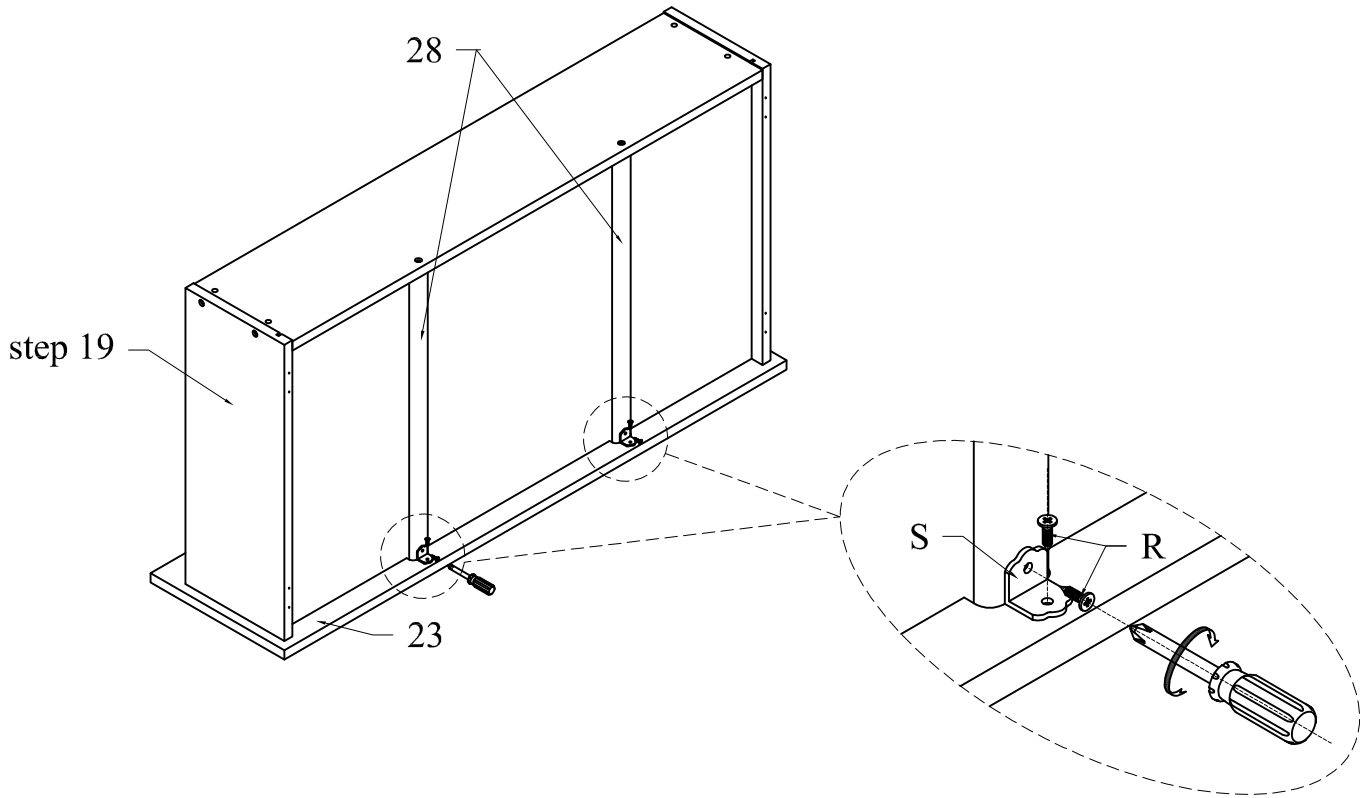

Étape

(R)		04
(S)		02



STEP 21

Étape

(R)		16
(T)		04

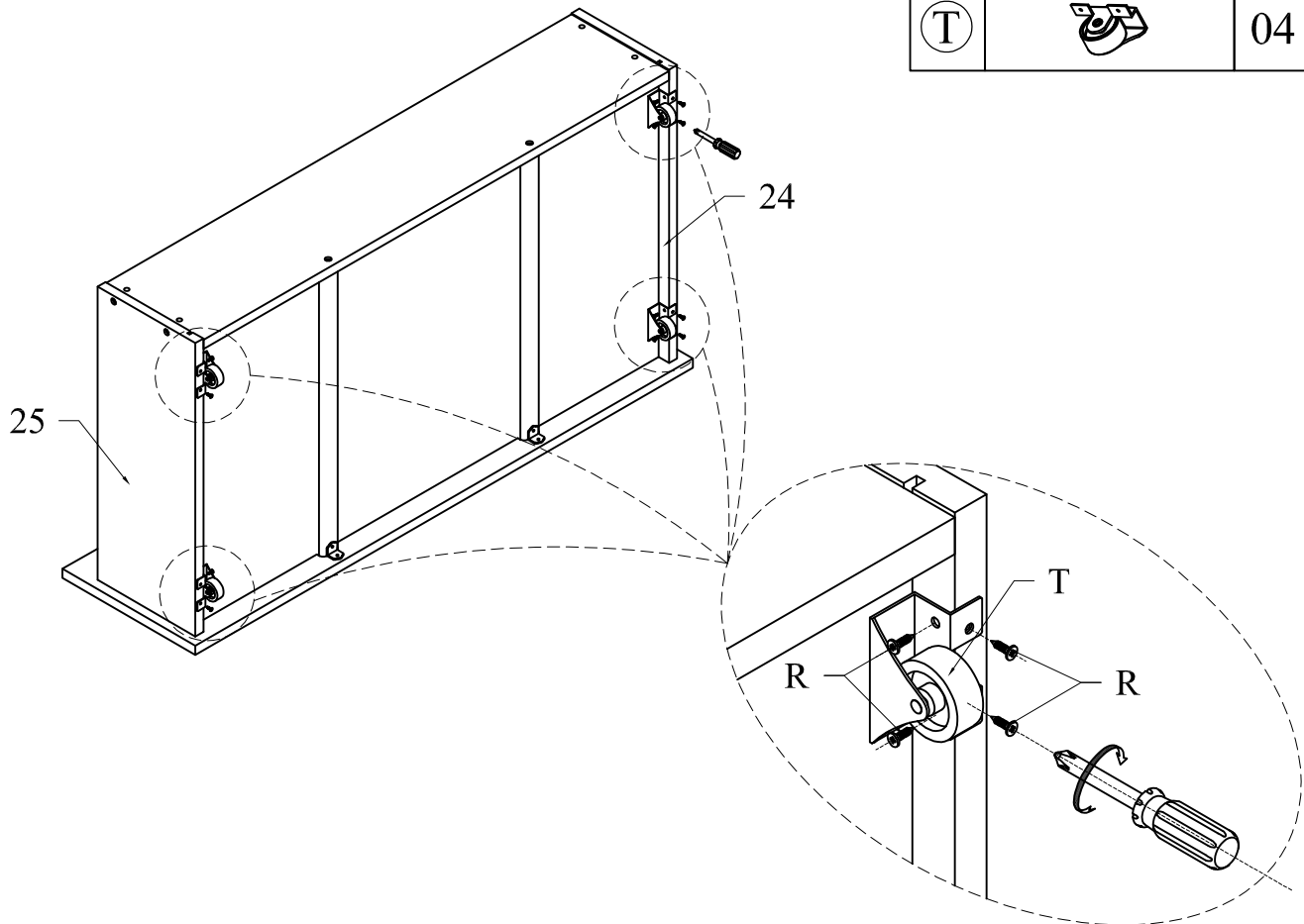

* ...Repeat the assembly steps from Step 17 to Step 21 to complete the second Drawer.

* ...Répétez les étapes d'assemblage de l'étape 17 à l'étape 21 pour terminer le deuxième tiroir.

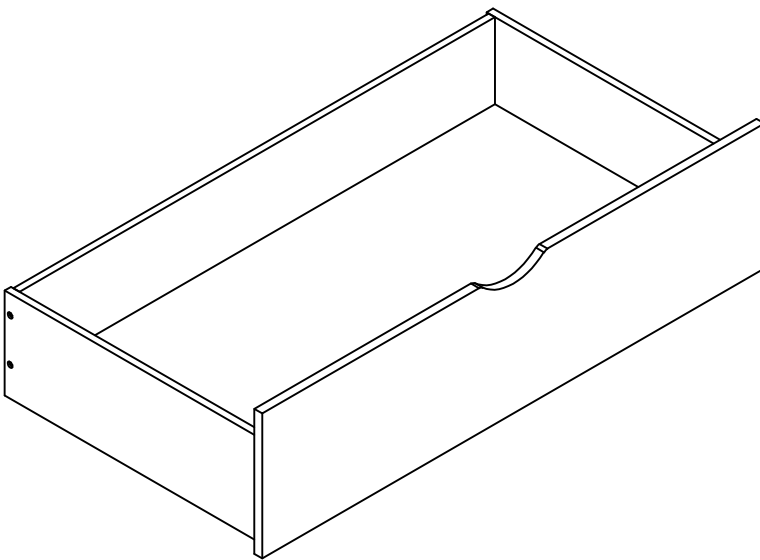

Drawer 1
Tiroir 1

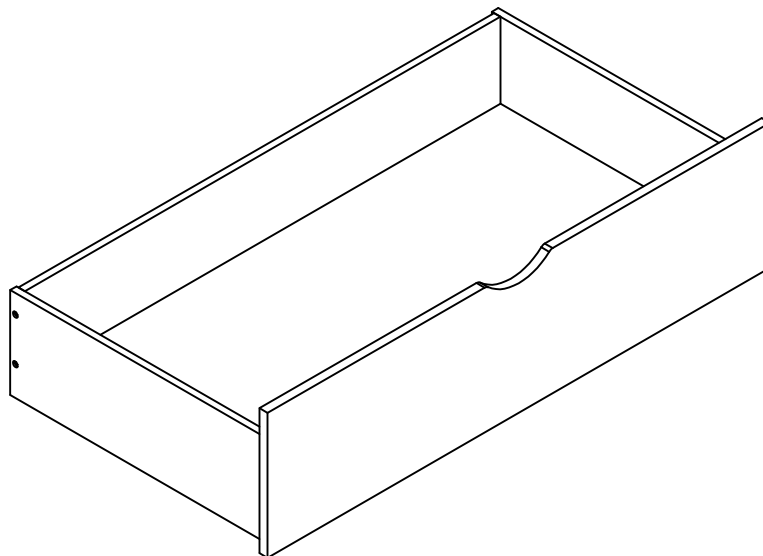

Drawer 2
Tiroir 2

STEP 22

Étape

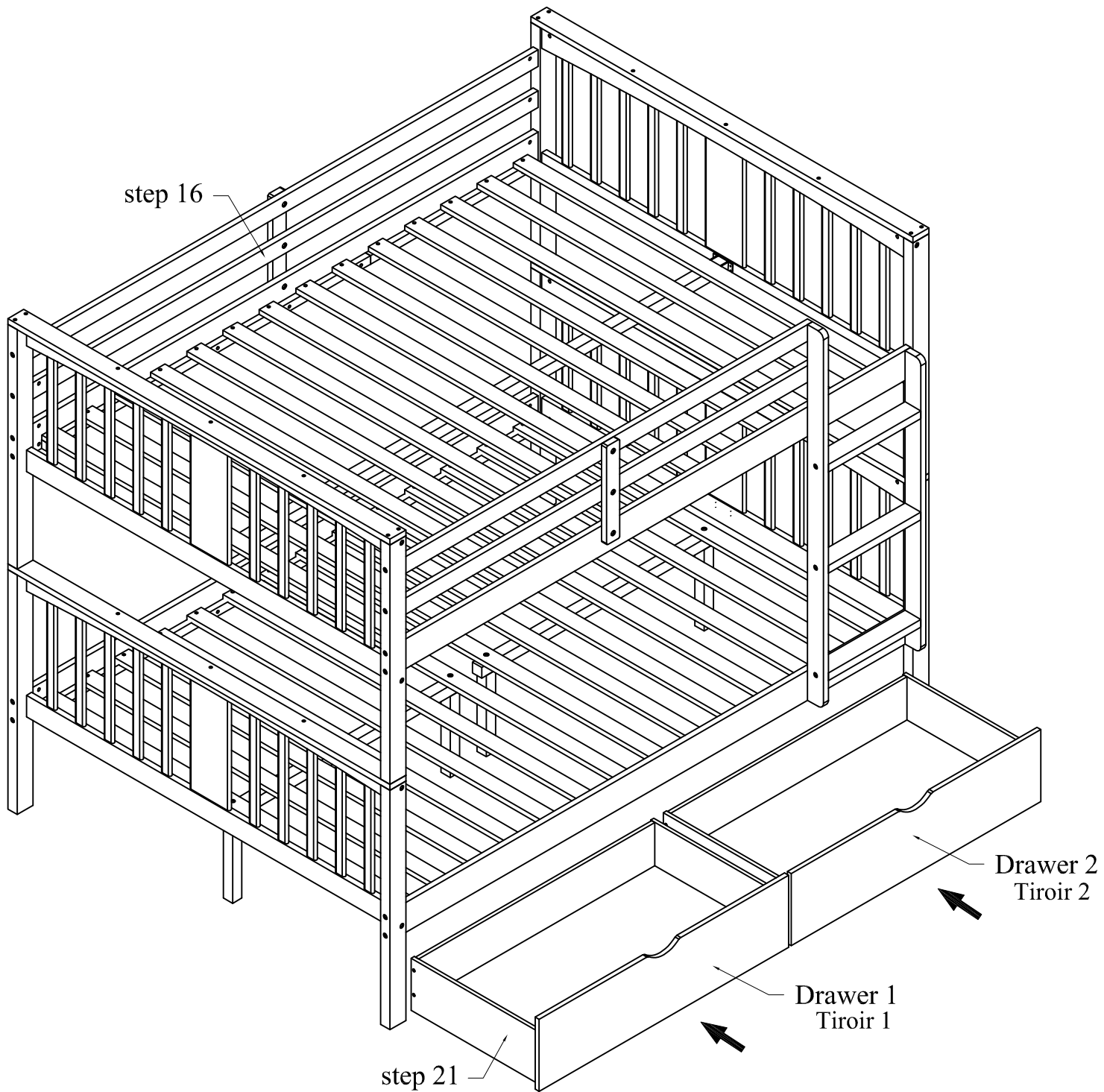

*- Note: After installation is complete, bolts must be tightened to ensure the most secure structure.

*- Remarque : Après l'installation, il faut serrer les boulons pour garantir une structure solide.

COMPLETE

