

Montageanweisung / Installation instructions / Instruction de montage / Istruzioni di montaggio
 montagehandleiding / Instrukcja montażu / Montaj talimatlar / Összeszerelési útmutató / Nàvod k montáži /
 Nàvod na montáž / Instrucțiune de montaj / Инструкция по монтажу / Montaj talimatina / Monteringsanvisningar
 Upute za montažu / Instrucciones de Montaje / Navodila za montažo

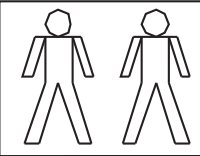
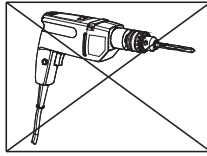

D Bitte lesen Sie diese Montageanleitung gut durch, da wir für Fehler, die durch falsche Montage entstehen, keine Haftung übernehmen!

GB Please read these installation instructions through carefully as we cannot accept any liability for faults occurring as a result of incorrect installation!

CZ Přečtěte si prosím pozorně tento návod k montáži, aby jste předešli chybám vzniklých špatnou montáží, za které neručíme!

F Veuillez lire attentivement cette notice de montage, car nous déclinons toute responsabilité en cas d'erreurs découlant d'un montage erroné !

I Prego leggere attentamente le istruzioni per il montaggio, poiché decliniamo qualsiasi responsabilità per difetti derivanti da un montaggio errato

S Läs monteringsanvisningarna noggrant. Vi avsäger oss allt ansvar för defekter som uppstår p.g.a. felaktig montering.

HR Pažljivo pročitajte upute za montažu, jer otklanjamo svaku odgovornost za pogreške nastale uslijed pogrešne montaže.

SLO Prosimo, da pozorno preberete navodila za montažo, saj zavračamo vsakršno odgovornost za napake, ki bi nastale zaradi napačne montaže.

NL Leest u alstublieft deze montagehandleiding goed door, voor fouten door verkeerde montage zijn wij niet verantwoordelijk.

PL Proszę uważnie zapoznać się z instrukcją montażu, ponieważ nie ponosimy odpowiedzialności za niewłaściwy montaż.

HU Kérjük, olvassa el figyelmesen ezt az összeszerelési útmutatót, mert a helytelen összeszerelésből a dódó hibákért nem vállalunk felelősséget!

SK Prosíme, dobre prečítajte si tento návod na montáž, pretože nepreberáme žiadne ručenie za chyby, ktoré vzniknú na základe chybnej montáže!

RO Vă rugăm să citiți cu atenție aceste instrucțiuni de montaj deoarece nu preluăm garanția pentru defecte ce apar datorită unui montaj incorect!

RUS Пожалуйста, внимательно ознакомьтесь с данной инструкцией по монтажу, поскольку мы не несем ответственности за ошибки, причиной которых является неправильный монтаж.

TU İlk önce kullanma klavuzunu iyi okuyun, yanlış montaj yaparsanız bunun sorumlusu biz degiliz.

E Se ruego leer con atención las instrucciones de montaje debido a que declinamos cualquier responsabilidad por defectos derivados de un montaje erróneo

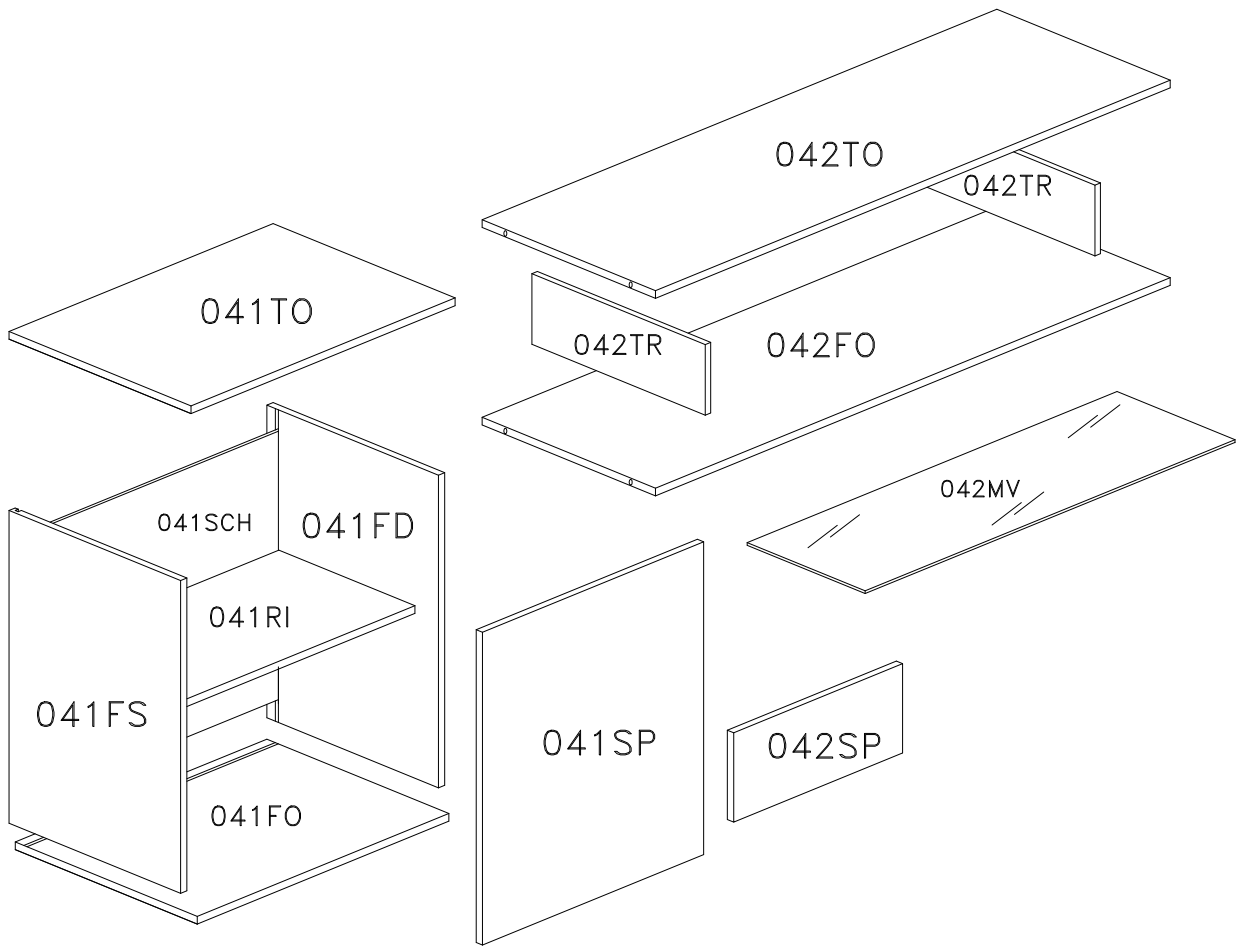
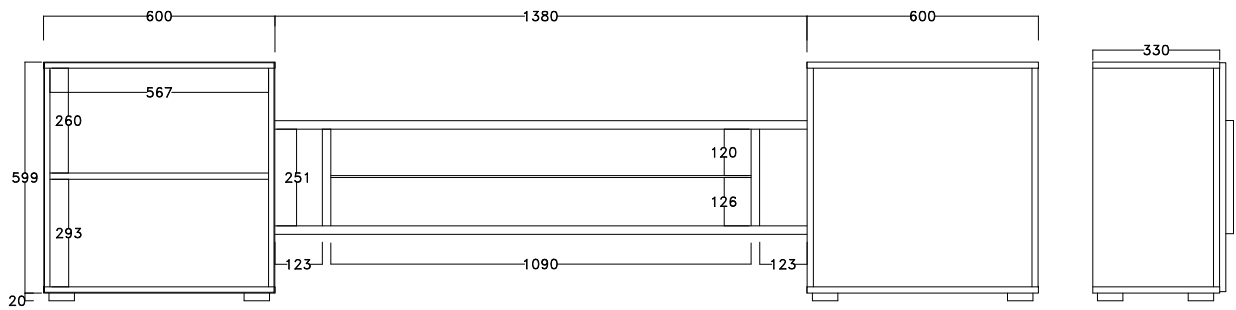

A		x16	L435		x4
B		x24	P		x4
C		x12	P12		8+4
D		x12	R1		
E		x20	R2		x8
L4530		x8	M11		x8

8x30 mm. 4x35 mm. 4x16 mm. 4x18 mm. 7x60 mm. 6x11 mm. 4.5x30 mm. 8x30 mm. 4x16 mm. 4x18 mm. 7x60 mm. 6x11 mm. 4.5x30 mm.

T		x2
L418		x2

4x18 mm.

L2		x8
N1		x4
O1		x4

4x16 mm.

1

3/10

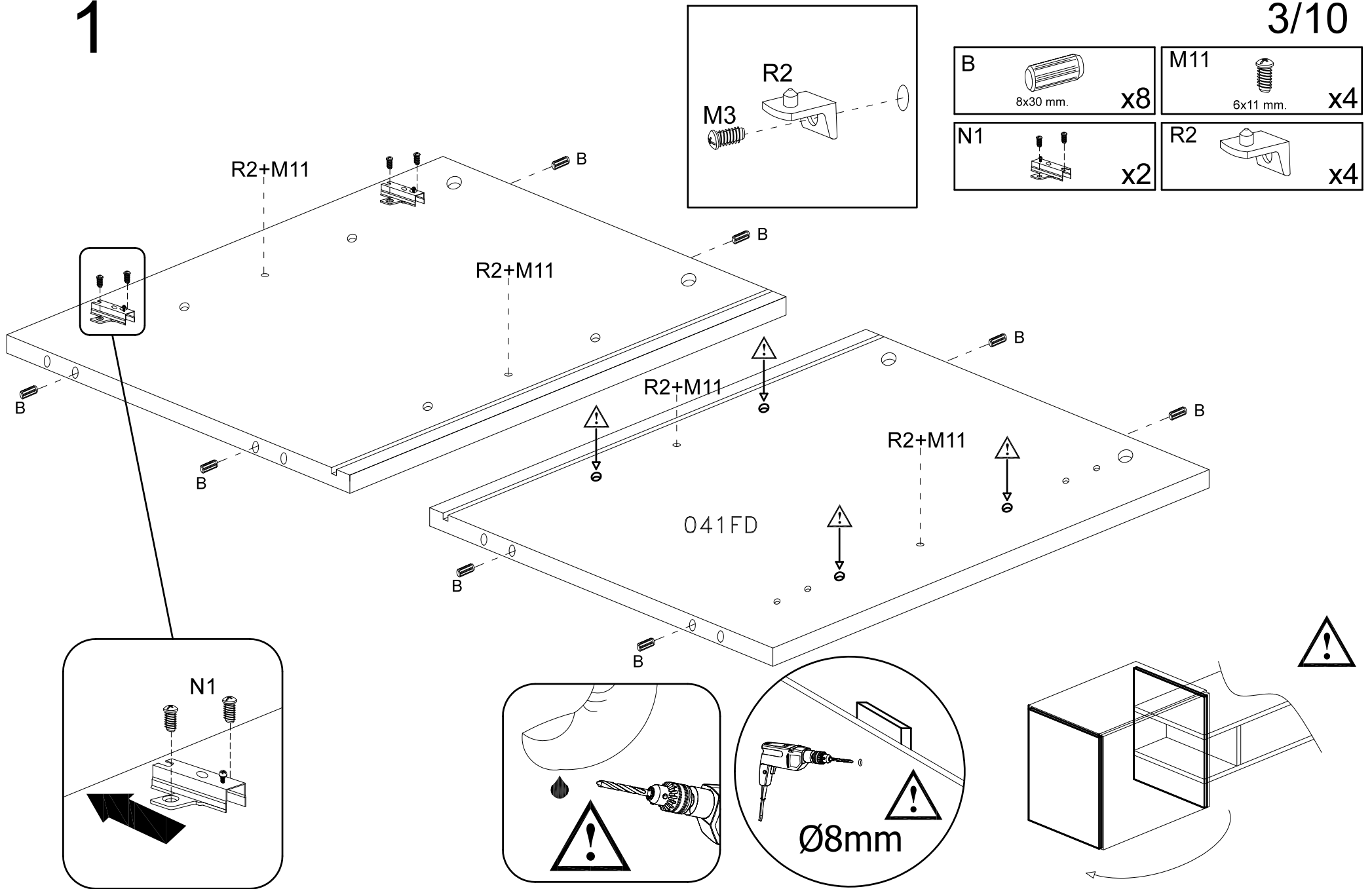

1

4/10

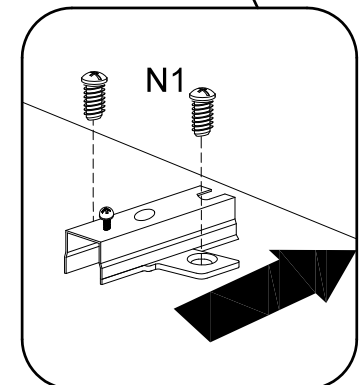
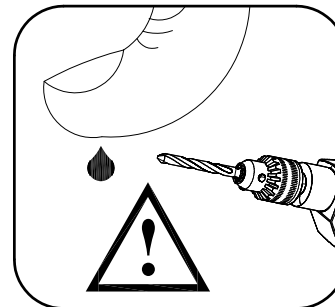
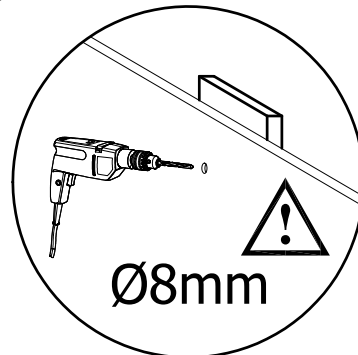
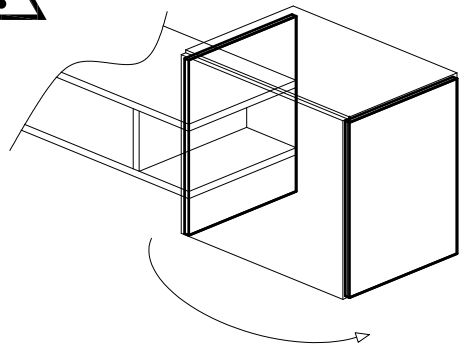
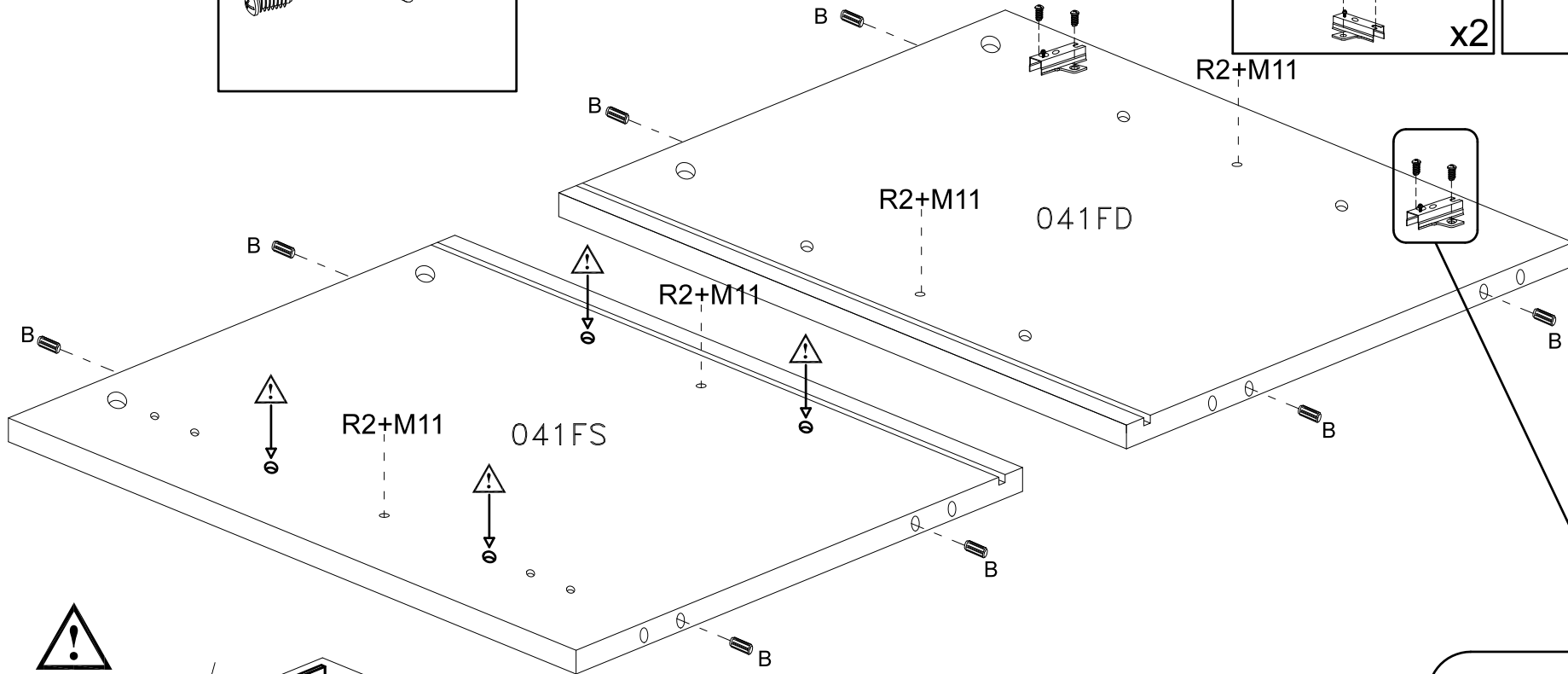
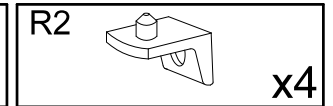
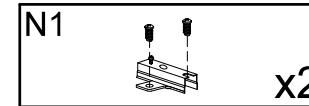
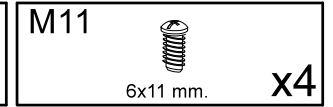
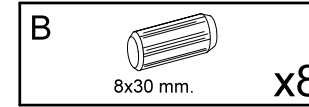
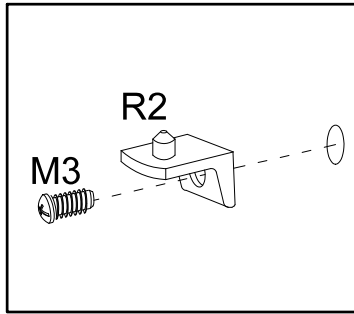

2

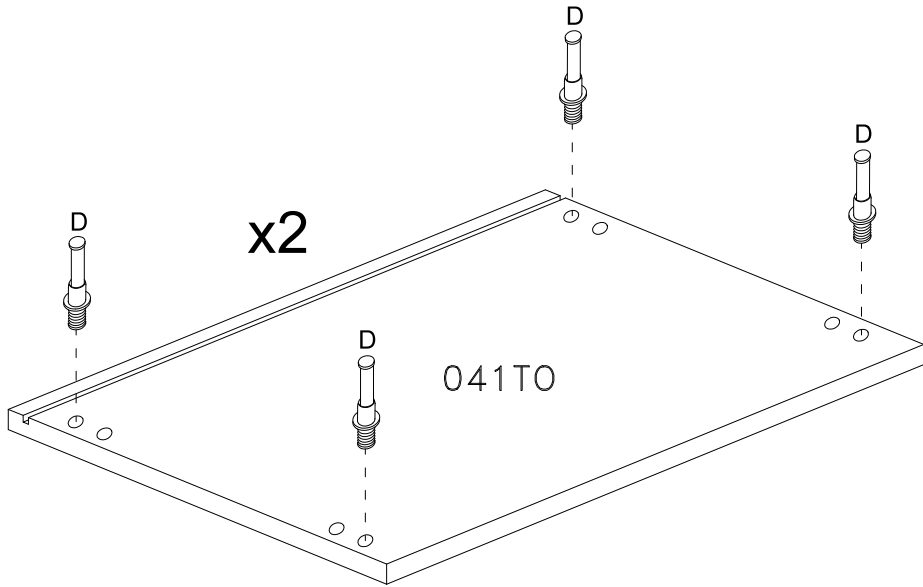
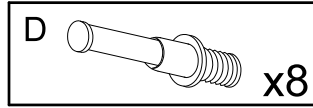

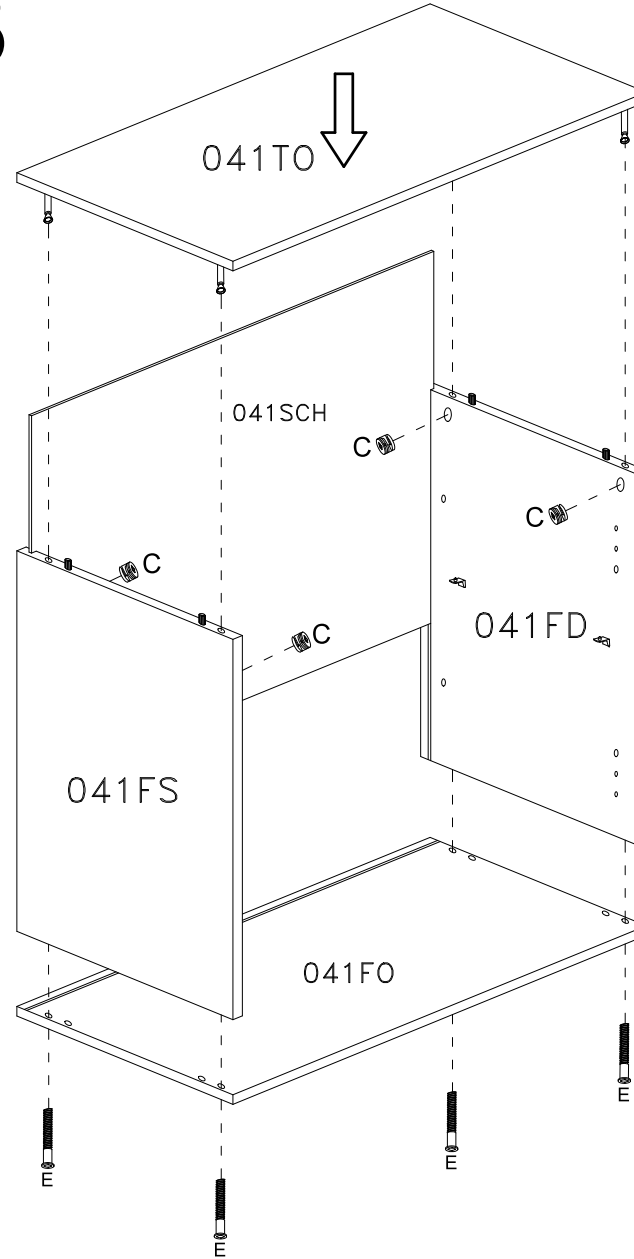

3

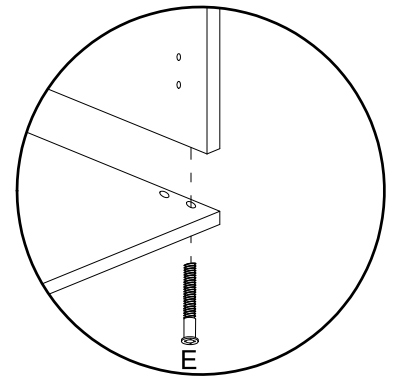
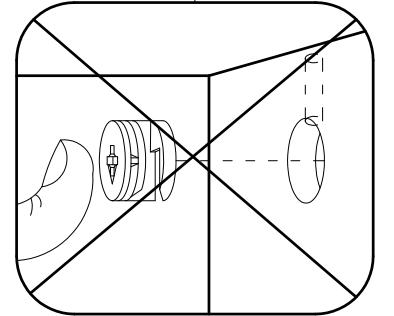
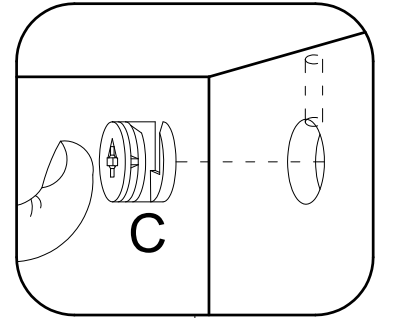
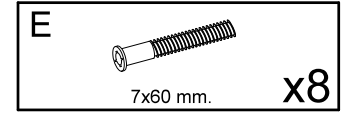
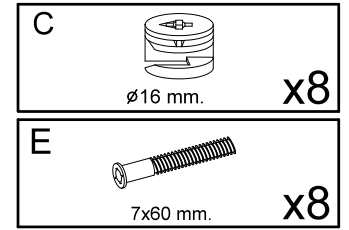

5/10



4

F19		x8
Ø 60 mm h 20 mm		
L4530		x8
4.5x30 mm.		

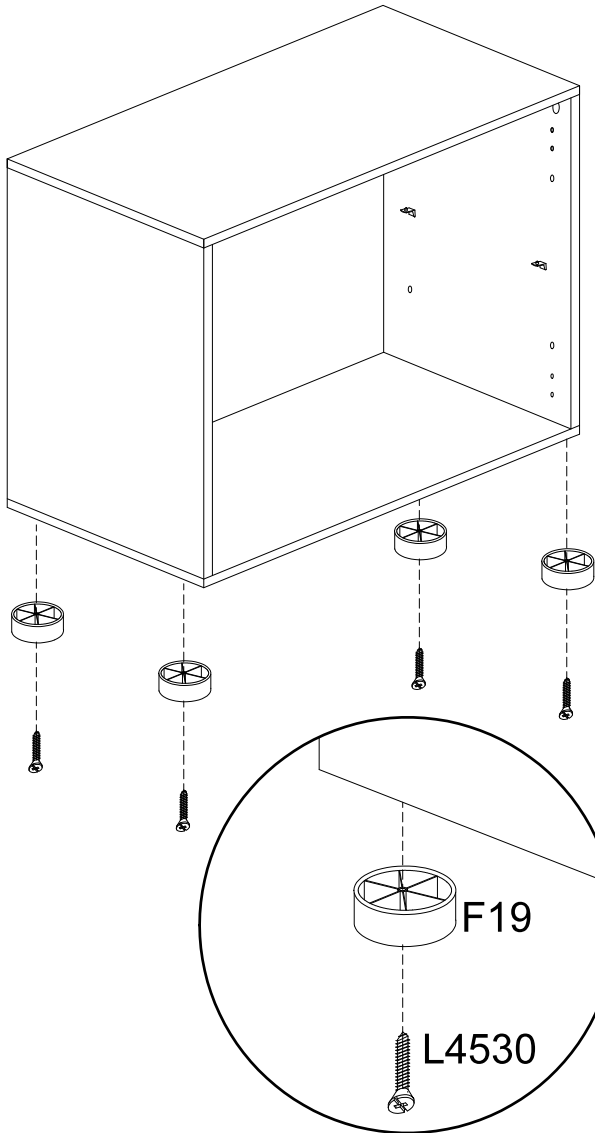



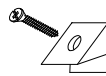

5

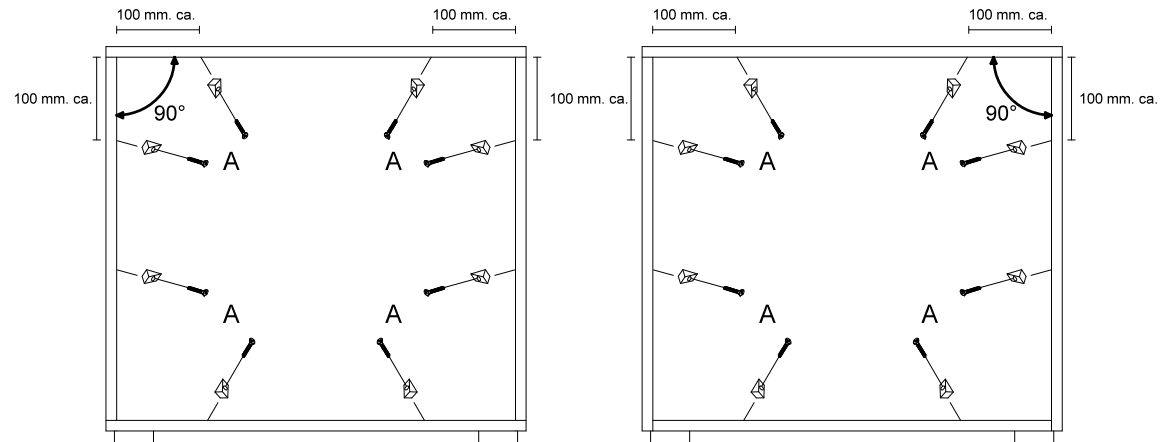
A		x16
---	---	-----

6/10

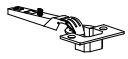

6

O1		x4	L435		x4	L2		x8	P		x4
			4x35 mm.			4x16 mm.					

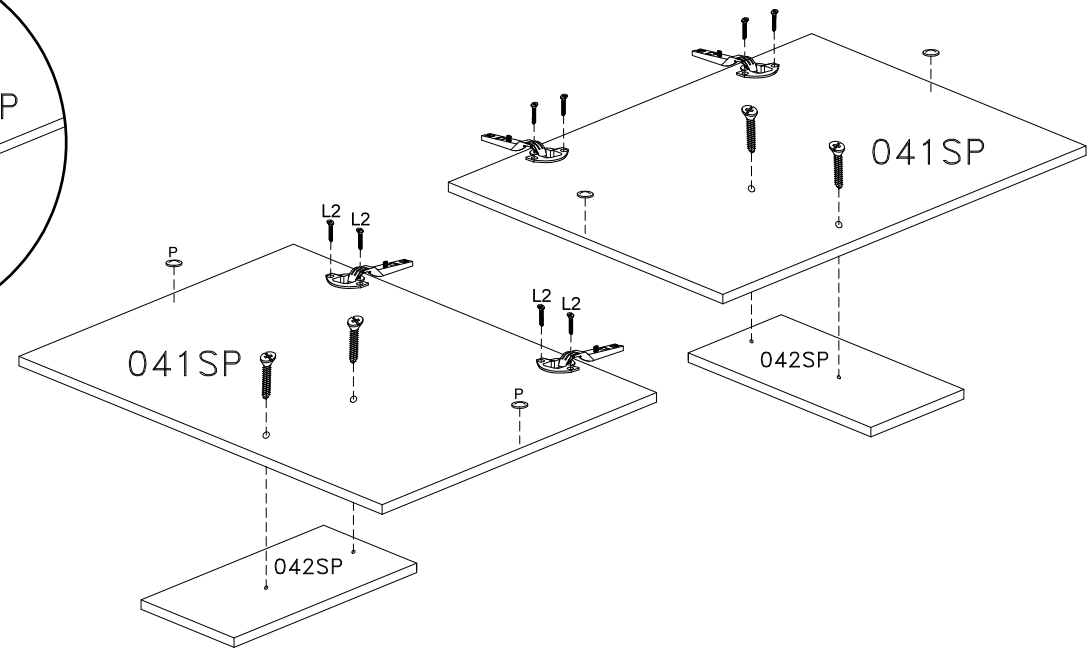
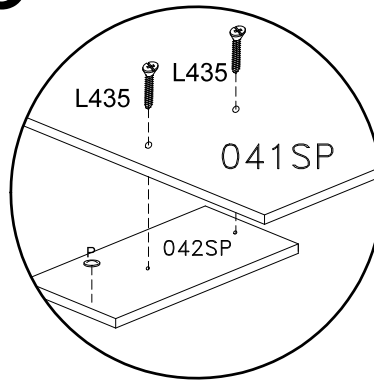

6

7/10

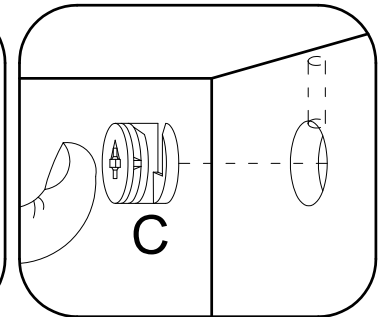
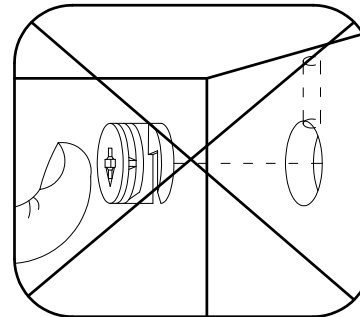
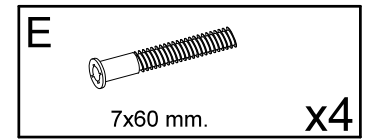
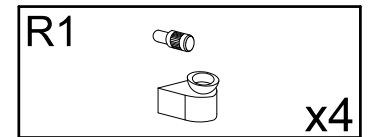
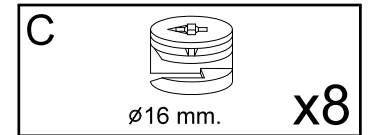
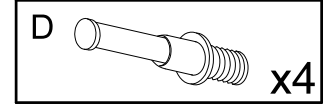
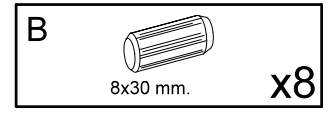
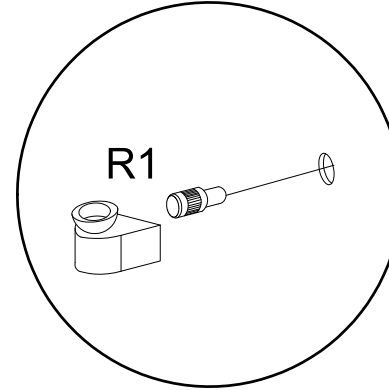
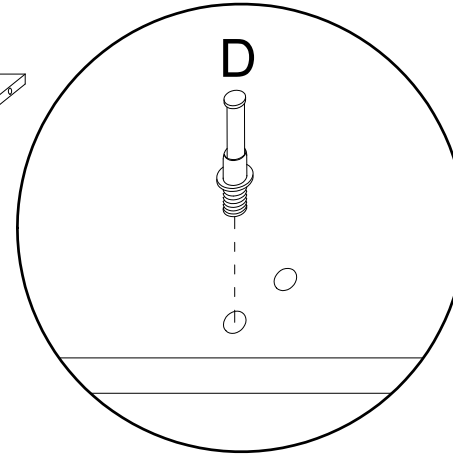
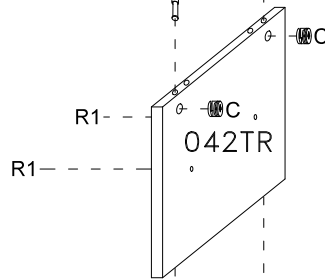
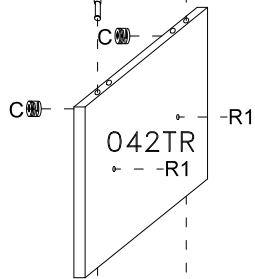
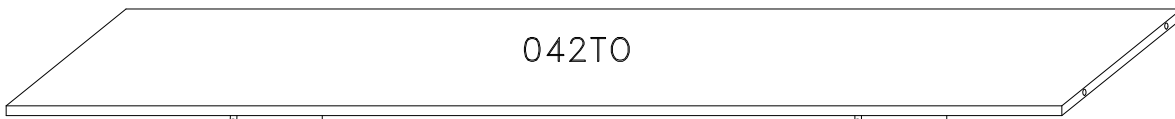
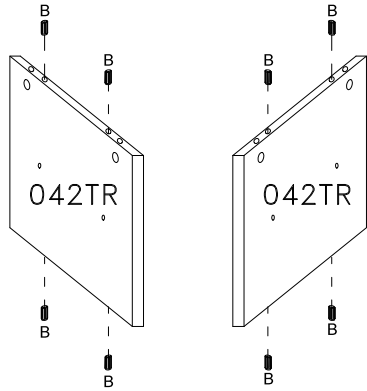

7

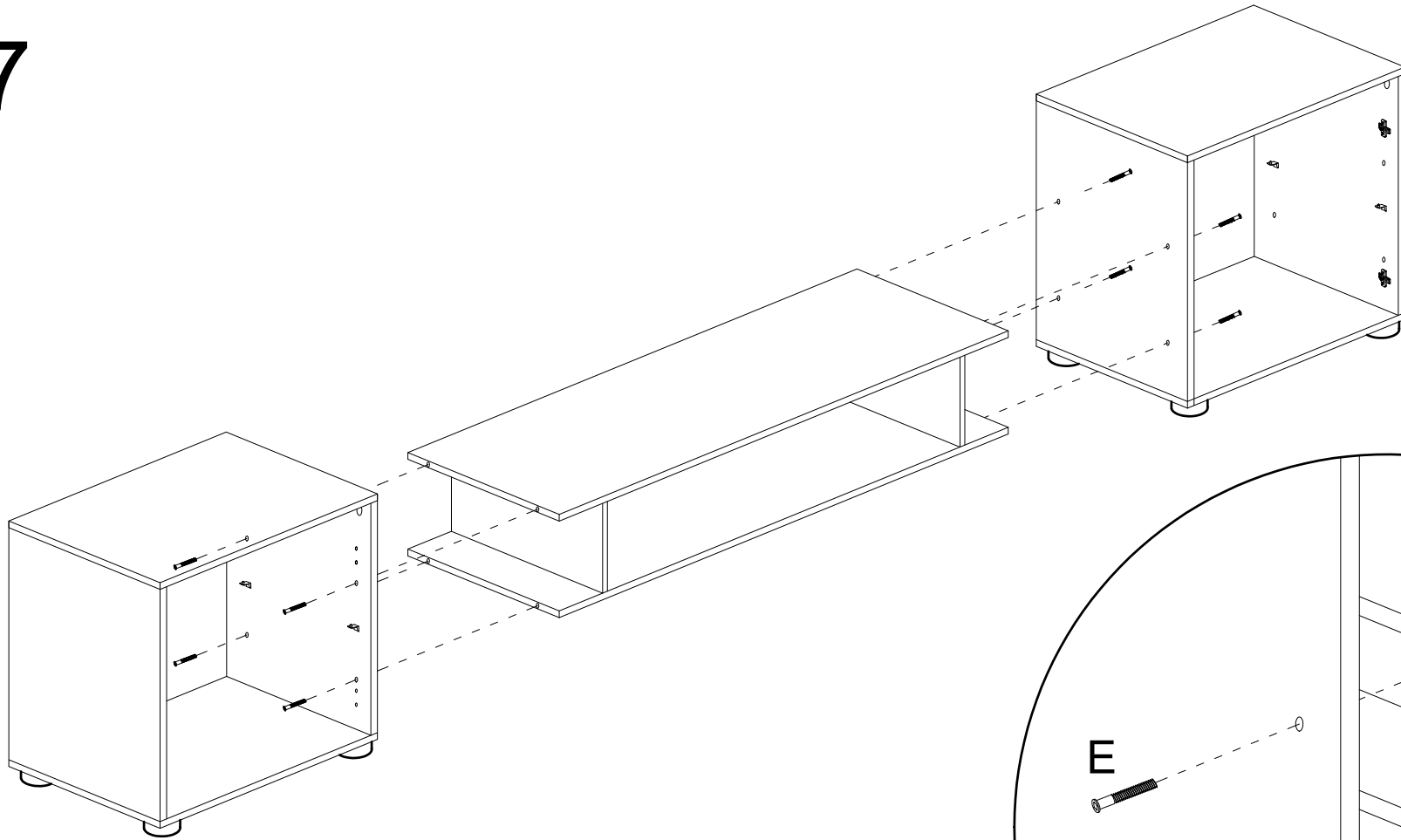

8/10

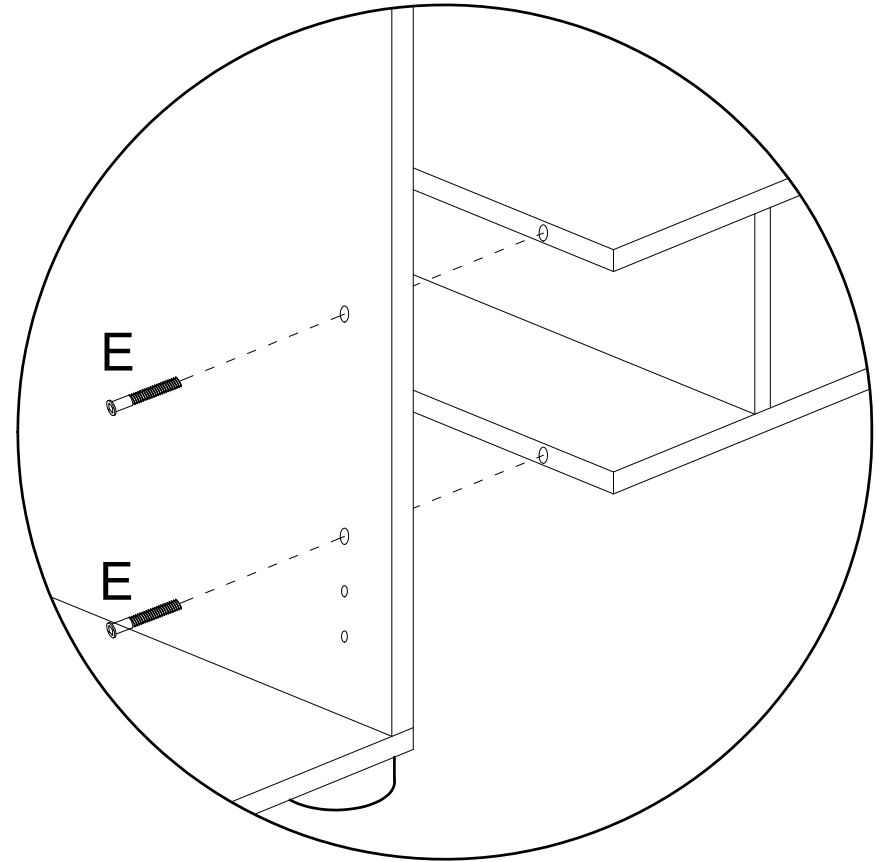
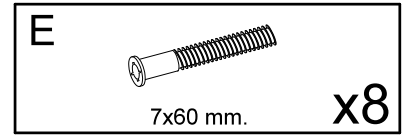

8

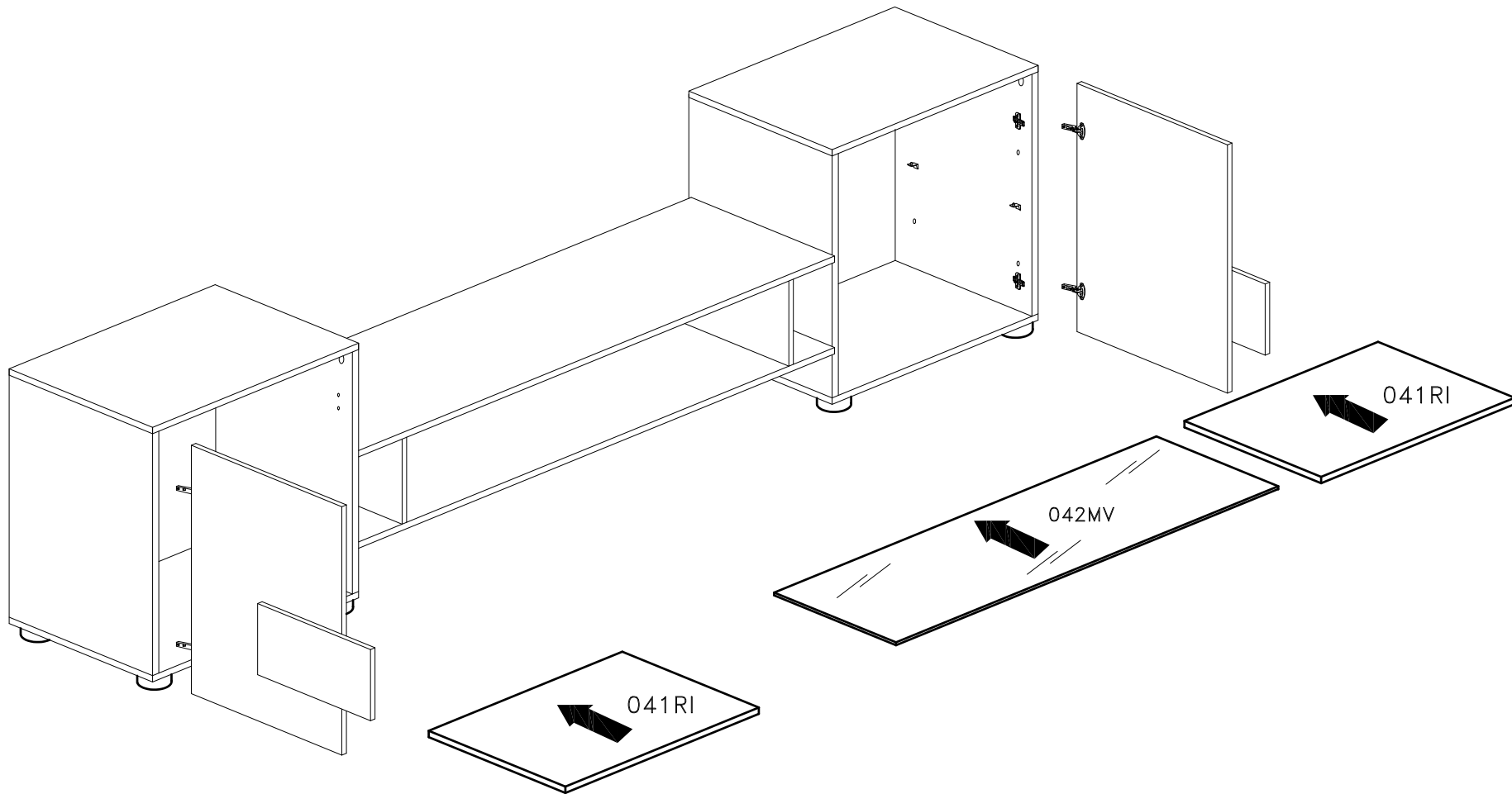

9/10

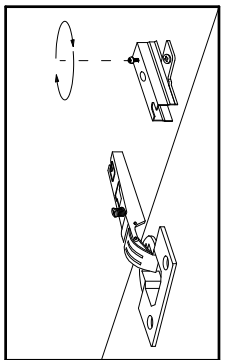
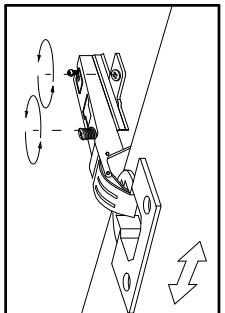
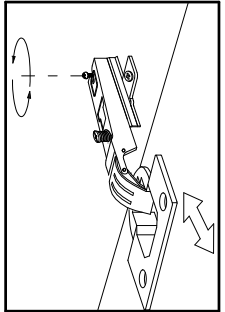
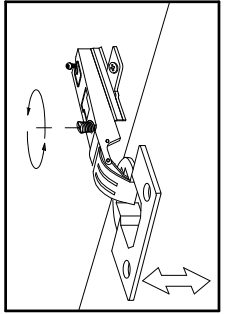

Cher client,
 l'installation des meubles suspendus doit être effectuée par un personnel compétent.
 Les fischers ne sont pas inclus dans la quincaillerie.
 Choisir les types des fischers pour le fixage apte au mur.
 S'assurer de l'adéquation du mur pour support sûr du meuble

Dear Customer
 The assembling of the hanging elements must be done by a competent staff.
 The fishers are not included in the hardware package.
 Choose the fisher more suitable to the type of the wall.
 Ensure the suitability of the wall for a secure support of the hanging element.

Sehr geehrter Kunde, die Montage der Haengeelemente muss von Fachpersonal ausgefuehrt werden!
 Bitte verwenden Sie eigene, der Beschaffenheit der Wand entsprechende Duebel. Zu Ihrer eigenen Sicherheit legen wir dem Beschlagbeutel keine Fischerduebel bei.

Gentile Cliente
 Il montaggio dei pensili deve essere effettuato da personale competente.
 I tasselli di fissaggio non sono compresi nella ferramenta.
 Scegliere il tipo di tassello per il fissaggio più adatto alla tipologia di muro.
 Assicurarsi l'idoneità della parete per un sostegno sicuro del pensile.

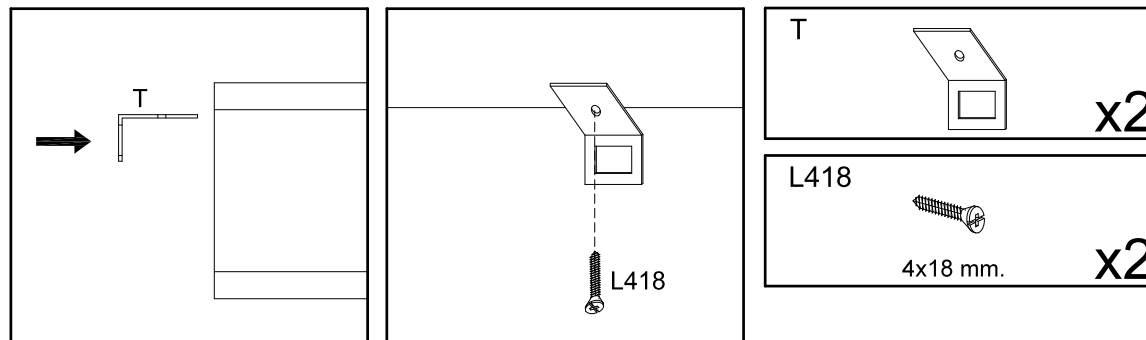

9

